

NOTICE

The information contained is for **DEALER REFERENCE PURPOSES ONLY**.
MANUALS ARE MODEL AND SERIAL NUMBER SPECIFIC.

If additional printed manuals are required for your shop/office location, order by part number through the factory's Parts Center.

If a retail customer needs replacement manual(s) for a specific unit, contact the factory's Customer Data Center at: 800-829-0051 or customerdata@vermeermfg.com

This page intentionally left blank.

Vermeer®

D150X300 NAVIGATOR® HORIZONTAL DIRECTIONAL DRILL



Parts Manual

P1.02
SERIAL NO. 101 -
ORDER NO. 105400DCP

HOW TO USE THE MANUAL

This manual contains illustrations and parts lists of components and assemblies which make up the machine. Each page consists of the name of the assembly or component, a figure number, reference numbers, part numbers, part names, and the quantities of the parts used.

Assembly or component name helps identify the illustration and parts list for each figure. This name also helps locate the general area of the machine where the assembly or component can be located.

Figure numbers are used to identify each assembly or component and to group these assemblies or components into major categories.

Reference numbers shown in a column refer to the numbered parts in the illustration. This ties the part in the illustration to the part number and description in the parts list.

An asterisk indicates information about the item has changed since the previous release of the parts manual. A note below the table often explains the change.

Part numbers are used to identify individual parts or part assemblies.

Part descriptions provide the name of the part, plus additional information such as dimensional specifications and what parts are grouped together to form part assemblies, which helps you identify the part(s).

Quantities listed for each figure are only for that assembly or component and not the total used per machine.

This parts manual is not intended to be a complete guide for machine service or repairs. Contact your Vermeer dealer for any of your service or technical requirements.

ORDERING PARTS

Parts for repair or replacement are available through our network of authorized dealers located throughout the world.

Use only authorized Vermeer parts for repair or replacement. Always give the serial number and

model number of the machine for which parts are being ordered. When ordering parts for component(s), which are not manufactured by Vermeer Manufacturing, also give the serial number of that component(s). Order all parts by part number, part name, and quantity needed.

UPDATING AND REORDERING MANUALS

The parts lists, illustrations, and specifications in this manual are based on the latest information available at time of publication. Your machine may have product improvements and options not yet contained in this manual.

Vermeer Manufacturing Company reserves the right to make changes at any time without notice or obligation to you.

Your dealer will receive notice of these changes and can assist you with accurate parts identification when ordering.

A copy of this manual is supplied with each machine. Additional copies are available through your dealer. When ordering additional manuals, use the reorder number listed on the front cover and the quantity needed.

No part of this manual may be reproduced in any form or by any means, electronic or mechanical, including photocopying, recording, or by any information storage and retrieval systems, without the express written consent of Vermeer Manufacturing Company.

Copyright © 2004 Vermeer Mfg. Co.
All rights reserved.
Vermeer Manufacturing Company
1210 Vermeer Road East, P.O. Box 200
Pella, Iowa 50219-0200, USA+

Decals/Literature Assy - Section 1

Decal Assy-Domestic Fig 1-1r01
 Decal Assy-Domestic Fig 1-1
 Decal Assy-Domestic Fig 1-1x01r01
 Decal Assy-Domestic Fig 1-1x01
 Decal Assy-Domestic Fig 1-1x02r01
 Decal Assy-Domestic Fig 1-1x02
 Decal Assy-Domestic Fig 1-1x03r01
 Decal Assy-Domestic Fig 1-1x03
 Decal Assy-Domestic Fig 1-1x04r01
 Decal Assy-Domestic Fig 1-1x04
 Decal Assy-Domestic Fig 1-1x05r01
 Decal Assy-Domestic Fig 1-1x05
 Decal Assy-International Fig 1-2r01
 Decal Assy-International Fig 1-2
 Decal Assy-International Fig 1-2x01r01
 Decal Assy-International Fig 1-2x01
 Decal Assy-International Fig 1-2x02r01
 Decal Assy-International Fig 1-2x02
 Decal Assy-International Fig 1-2x03r01
 Decal Assy-International Fig 1-2x03
 Decal Assy-International Fig 1-2x04r01
 Decal Assy-International Fig 1-2x04
 Decal Assy-International Fig 1-2x05r01
 Decal Assy-International Fig 1-2x05
 Decal Location Assy-1 Fig 1-3r01
 Decal Location Assy-1 Fig 1-3
 Decal Location Assy-2 Fig 1-4r02
 Decal Location Assy-2 Fig 1-4r01
 Decal Location Assy-2 Fig 1-4
 Decal/Literature Box Assy Fig 1-5R01
 Decal/Literature Box Assy Fig 1-5

Frame Assy - Section 2

Frame-Mainframe Fig 2-1r02
 Frame-Mainframe Fig 2-1r01
 Frame-Mainframe Fig 2-1
 Frame-Rack Assy Fig 2-2r02
 Frame-Rack Assy Fig 2-2r01
 Frame-Rack Assy Fig 2-2
 Frame-Track Frame Assy Fig 2-3r01
 Frame-Track Frame Assy Fig 2-3
 Frame-Track Drive Gearbox/Sprocket Assy Fig 2-4
 Frame-Track Tension Assy Fig 2-5r02
 Frame-Track Tension Assy Fig 2-5r01
 Frame-Track Tension Assy Fig 2-5
 Frame-Track Chain & Roller Assy Fig 2-6
 Frame-Catwalk Assy Fig 2-7r02
 Frame-Catwalk Assy Fig 2-7r01
 Frame-Catwalk Assy Fig 2-7

Frame-Catwalk Handrail Assy Fig 2-8r01
 Frame-Catwalk Handrail Assy Fig 2-8
 Frame-Rotation Gearbox/Carriage Assy Fig 2-9r02
 Frame-Rotation Gearbox/Carriage Assy Fig 2-9r01
 Frame-Rotation Gearbox/Carriage Assy Fig 2-9
 Frame-Gearbox Components Assy Fig 2-10r01
 Frame-Gearbox Components Assy Fig 2-10
 Frame-Gearbox Rotation Sensor Assy Fig 2-11
 Frame-Drive Chuck Assy Fig 2-12
 Frame-Battery Box Assy Fig 2-13r02
 Frame-Battery Box Assy Fig 2-13r01
 Frame-Battery Box Assy Fig 2-13
 Frame-Rod Cradle Assy Fig 2-14
 Frame-Deadman Assy Fig 2-15r02
 Frame-Deadman Assy Fig 2-15r01
 Frame-Deadman Assy Fig 2-15
 Frame-Wireline Assy Fig 2-16
 Frame-Ladder Assy Fig 2-17
 Frame- Rack Position PPU Assy Fig 2-18r01
 Frame-Rotation PPU Assy Fig 2-18

Engine Assy - Section 3

Engine Components Fig 3-1
 Engine Components Fig 3-2r01
 Engine Components (Continued)..... Fig 3-2r01
 Engine Components Fig 3-2
 Engine Components (Continued)..... Fig 3-2
 Engine - Pully Drive Assy Fig 3-3r02
 Engine - Pully Drive Assy Fig 3-3r01
 Engine - Pully Drive Assy Fig 3-3
 Engine - Alternator Assy Fig 3-4
 Engine - Pump Drive Assy Fig 3-5r01
 Engine - Pump Drive Assy Fig 3-5
 Engine - Remote Oil Filter Assy Fig 3-6r01
 Engine - Remote Oil Filter Assy Fig 3-6
 Engine - Fan Assy Fig 3-7
 Engine - Radiator Assy Fig 3-8
 Engine - Ether Start Assy Fig 3-9r01
 Engine - Ether Start Assy Fig 3-9
 Engine - Muffler Assy Fig 3-10r01
 Engine - Muffler Assy Fig 3-10
 Engine - Air Cleaner Assy Fig 3-11r01
 Engine - Air Cleaner Assy Fig 3-11
 Engine Bay Assy Fig 3-12r01
 Engine Bay Assy Fig 3-12
 Engine Mount Assy Fig 3-13r01
 Engine Mount Assy Fig 3-13
 Engine - Expansion Tank Assy Fig 3-14r01
 Engine - Expansion Tank Assy Fig 3-14
 Engine - Fuel Tank Assy Fig 3-15r01
 Engine - Fuel Tank Assy Fig 3-15
 Engine - Fuel Vent Assy Fig 3-16

Shield Assy - Section 4

Shield-Engine Side Assy	Fig 4-1r01
Shield-Engine Side Assy	Fig 4-1
Shield-Radiator Top Assy	Fig 4-2r02
Shield-Radiator Top Assy	Fig 4-2r01
Shield-Radiator Top Assy	Fig 4-2
Shield-Top Rear Engine Bay Assy	Fig 4-3r01
Shield-Top Rear Engine Bay Assy	Fig 4-3
Shield-Top Front Engine Bay Assy	Fig 4-4
Shield-Engine Assy	Fig 4-5
Shield-Right/Left Top Corner Assy	Fig 4-6
Shield-Door Track Assy	Fig 4-7
Shield-Floating Door Assy	Fig 4-8

Hydraulic Assy - Section 5

Hyd-Pump-Ground Drive/Thrust-Pullback Assy	Fig 5-1r01
Hyd-Pump-Ground Drive/Thrust-Pullback Assy	Fig 5-1
Hyd-Pump-Ground Drive/Thrust-Pullback Assy	Fig 5-2r01
Hyd-Pump-Ground Drive/Thrust-Pullback Assy	Fig 5-2
Hyd-Pump-Rotation Assy	Fig 5-3r01
Hyd-Pump-Rotation Assy	Fig 5-3
Hyd-Pump-Rotation Assy	Fig 5-4r01
Hyd-Pump-Rotation Assy	Fig 5-4
Hyd-Pump-Fan Assy	Fig 5-5
Hyd-Pump-Heat/Cool/Filter Assy	Fig 5-6r02
Hyd-Pump-Heat/Cool/Filter Assy	Fig 5-6r01
Hyd-Pump-Heat/Cool/Filter Assy	Fig 5-6
Hyd-Pump-Pressure Compensator Assy	Fig 5-7r02
Hyd-Pump-Pressure Compensator Assy	Fig 5-7r01
Hyd-Pump-Pressure Compensator Assy	Fig 5-7
Hyd-Motor-Track Drive Assy	Fig 5-8r01
Hyd-Motor-Track Drive Assy	Fig 5-8
Hyd-Motor-Track Drive Assy	Fig 5-9r02
Hyd-Motor-Track Drive Assy	Fig 5-9r01
Hyd-Motor-Track Drive Assy	Fig 5-9
Hyd-Motor-Fan Drive Assy	Fig 5-10
Hyd-Motor-Rotation Drive Assy	Fig 5-11
Hyd-Motor-Thrust/Pullback Drive Assy(LF)	Fig 5-12r01
Hyd-Motor-Thrust/Pullback Drive Assy(RF)	Fig 5-12x01
Hyd-Motor-Thrust/Pullback Drive Assy(LM)	Fig 5-12x02
Hyd-Motor-Thrust/Pullback Drive Assy(RM)	Fig 5-12x03
Hyd-Motor-Thrust/Pullback Drive Assy(LR)	Fig 5-12x04
Hyd-Motor-Thrust/Pullback Drive Assy(RR)	Fig 5-12x05
Hyd-Motor-Thrust/Pullback Drive Assy	Fig 5-12
Hyd-Cylinder-Catwalk Assy	Fig 5-13
Hyd-Cylinder-Rod Cradle Assy	Fig 5-14
Hyd-Cylinder-Handrail Assy	Fig 5-15
Hyd-Cylinder-Rack Lift Assy	Fig 5-16r02
Hyd-Cylinder-Rack Lift Assy	Fig 5-16r01

Hyd-Cylinder-Track Tension(Engine Side) Assy	Fig 5-16x01
Hyd-Cylinder-Track Tension(Rack Side) Assy	Fig 5-16x02
Hyd-Cylinder-Rack Lift Assy	Fig 5-16
Hyd-Manifold-Pc Distribution Pump Assy	Fig 5-17r02
Hyd-Manifold-Pc Distribution Pump Assy	Fig 5-17r01
Hyd-Manifold-Pc Distribution Pump Assy	Fig 5-17
Hyd-Manifold-Case Drain Assy	Fig 5-18r01
Hyd-Manifold-Case Drain Assy	Fig 5-18
Hyd-Manifold-Case Drain Assy	Fig 5-19
Hyd-Manifold-Diagnostic Assy	Fig 5-20r02
Hyd-Manifold-Diagnostic Assy	Fig 5-20r01
Hyd-Manifold-Diagnostic Assy	Fig 5-20
Hyd-Valve-High Speed Assy	Fig 5-21r01
Hyd-Valve-Carriage Drive Motor Bleeder	Fig 5-22r01
Hyd-Valve-Carriage Drive Motor Bleeder	Fig 5-22
Hyd-Valve-Diverter Assy	Fig 5-23r01
Hyd-Valve-Diverter Assy	Fig 5-23
Hyd-Valve-Catwalk Multi-Function Assy	Fig 5-24r01
Hyd-Valve-Catwalk Multi-Function Assy	Fig 5-24
Hyd-Valve-3 Speed Flush Assy	Fig 5-25x01
Hyd-Valve-3 Speed Flush Assy	Fig 5-25
Hyd-Manifold-Rotation Gearbox Assy	Fig 5-26
Hyd-High Pressure Filter Assy	Fig 5-27
Hyd-Oil Cooler Assy	Fig 5-28
Hyd-Oil Tank Assy	Fig 5-29r02
Hyd-Oil Tank Assy	Fig 5-29r01
Hyd-Oil Tank Assy (Continued)	Fig 5-29r02
Hyd-Oil Tank Assy (Continued)	Fig 5-29r01
Hyd-Oil Tank Assy	Fig 5-29
Hyd-Oil Tank Assy	Fig 5-30r01
Hyd-Oil Tank Assy	Fig 5-30
Hyd-Hose Carrier Assy	Fig 5-31r01
Hyd-Hose Carrier Assy	Fig 5-31
Hyd-Main Frame Manifold	Fig 5-32
Miscellaneous	Fig 5-33
Hyd-Cold Start Vavle Assy	Fig 5-34

Cab Assy - Section 6

Cab/Mainframe Mounting Assy	Fig 6-1r01
Cab/Mainframe Mounting Assy	Fig 6-1
Cab-Foam Assy	Fig 6-2r01
Cab-Foam Assy	Fig 6-2
Cab Window Assy	Fig 6-3r03
Cab Window Assy	Fig 6-3r02
Cab Window Assy	Fig 6-3r01
Cab Window Assy	Fig 6-3
Cab Door Assy	Fig 6-4
Cab-Door Latch Assy	Fig 6-5r01
Cab-Door Latch Assy	Fig 6-5
Cab-16" Jump Seat Assy	Fig 6-6
Cab-Seat-Mechanical Assy	Fig 6-7
Cab-Side Table Assy	Fig 6-8
Cab-Handrail/Step Assy	Fig 6-9r01
Cab-Handrail/Step Assy	Fig 6-9

Cab-Wiper Motor Assy Fig 6-10r02
 Cab-Wiper Motor Assy Fig 6-10r01
 Cab-Wiper Motor Assy Fig 6-10
 Cab Fan Assy Fig 6-11
 Cab-Air Conditioner Component Coolant Diagram Fig 6-12
 Cab-Heater/Air Conditioner Assy Fig 6-13
 Cab-Air Conditioner Filter Assy Fig 6-14
 Cab-Compressor Assy Fig 6-15
 Cab-Receiver Dryer Assy Fig 6-16
 Cab-Air Conditioner Condenser Assy Fig 6-17r01
 Cab-Air Conditioner Condenser Assy Fig 6-17
 Harness Cap Assy..... Fig 6-18r01
 Harness Cap Assy..... Fig 6-18

Control/Electrical Assy - Section 7

Control/Electrical-Wire Harness Assy Fig 7-1r02
 Control/Electrical-Wire Harness Assy Fig 7-1r01
 Control/Electrical-Wire Harness Assy Fig 7-1
 Control/Electrical Box Assy Fig 7-2r01
 Control/Electrical Box Assy Fig 7-2
 Control/Electrical- Battery Assy Fig 7-3r01
 Control/Electrical- Battery Assy Fig 7-3
 Control/Electrical -Seat Assy Fig 7-4r02
 Control/Electrical -Seat Assy Fig 7-4r01
 Control/Electrical -Seat Assy (Continued) Fig 7-4r02
 Control/Electrical -Seat Assy (Continued) Fig 7-4r01
 Control/Electrical -Seat Assy Fig 7-4
 Console/Electrical- Seat Assy Fig 7-5r02
 Console/Electrical- Seat Assy Fig 7-5r01
 Console/Electrical- Seat Assy Fig 7-5
 Control/Electrical-Dome Light Assy Fig 7-6
 Control/Electrical-Work Light Assy Fig 7-7
 Control/Electrical Communication Panel Assy Fig 7-8r01
 Control/Electrical Communication Panel Assy Fig 7-8
 Control/Electrical-Back-Up/High Pitch/Zap Alert Horn Assy Fig 7-9
 Control/Electrical-DT Series Connectors Fig 7-10
 Control/Electrical-DRC Series Fig 7-11
 Control/Electrical-DRC Series (Continued) Fig 7-11
 Control/Electrical-Overhead Console Assy Fig 7-12r02
 Control/Electrical-Overhead Console Assy Fig 7-12r01
 Control/Electrical-Overhead Console Assy Fig 7-12
 Rmote Lockout Assy..... Fig 7-13r01
 Rmote Lockout Assy..... Fig 7-13

Vise Assy - Section 8

Vise Scissor Guard Assy S/N 111..... Fig 8-1r03
 Figure Deleted Fig 8-1r02
 Vise Box - Assy S/N 97-104 & 106 Fig 8-1r01
 Vise Box - Assy Fig 8-1
 Vise Box-Bridge Assy S/N 111- Fig 8-2r01
 Vise Box-Bridge Assy S/N 105 & 107-110..... Fig 8-2

Vise Box Plumbing Assy S/N 111-..... Fig 8-3r01
 Vise Box Plumbing Assy S/N 105 & 107-110 Fig 8-3
 Vise Scissor Assy S/N 111-..... Fig 8-4r01
 Vise Scissor Assy S/N 105 & 107-110 Fig 8-4
 Vise Drive Frame Assy S/N 111-..... Fig 8-5r01
 Vise Drive Frame Assy S/N 105 & 107-110 Fig 8-5
 Vise Spread Cylinder Assy S/N 111-..... Fig 8-6r01
 Vise Spread Cylinder Assy S/N 105 & 107-110 Fig 8-6
 Vise Travel Motor Assy S/N 111-..... Fig 8-7r01
 Vise Travel Motor Assy S/N 105 & 107-110 Fig 8-7
 Vise Clamp Valve Assy S/N 111-..... Fig 8-8r01
 Vise Clamp Valve Assy S/N 105 & 107-110 Fig 8-8
 Vise Lift Valve Assy S/N 111-..... Fig 8-9r01
 Vise Lift Valve Assy S/N 105 & 107-110 Fig 8-9
 Vise Scissor Rotation Assy S/N 111-..... Fig 8-10r01
 Vise Scissor Rotation Assy S/N 105 & 107-110..... Fig 8-10
 Vise Scissor Rotation Bulkhead Assy S/N 111-..... Fig 8-11r01
 Vise Scissor Rotation Bulkhead Assy S/N 105 & 107-110 Fig 8-11
 Vise Scissor Drive Assy S/N 111-..... Fig 8-12r01
 Vise Scissor Drive Assy S/N 105 & 107-110 Fig 8-12
 Vise Center Support S/N 111-..... Fig 8-13r01
 Vise Center Support S/N 105 & 107-110..... Fig 8-13
 Vise Scissor Vise Manifold Assy S/N 111-..... Fig 8-14r01
 Vise Scissor Vise Manifold Assy S/N 105 & 107-110 Fig 8-14

Cable Crane Assy - Section 9

Cable Crane-Hyd Flow Diagram Fig 9-1
 Cable Crane-Frame Assy Fig 9-2r01
 Cable Crane-Frame Assy Fig 9-2
 Cable Crane-Base Lock Cylinder Assy Fig 9-3r01
 Cable Crane-Base Lock Cylinder Assy Fig 9-3
 Cable Crane-Contoller Assy (Deleted)..... Fig 9-4r01
 Cable Crane-Contoller Assy Fig 9-4
 Cable Crane-Base Assy Fig 9-5
 Cable Crane-Mast Assy Fig 9-6
 Cable Crane-Extension Boom Assy Fig 9-7
 Cable Crane-Lower Boom Assy Fig 9-8
 Cable Crane-Winch/Cable/Hook Assy Fig 9-9
 Cable Crane-Winch/Cable/Hook Assy (Continued) Fig 9-9
 Cable Crane-Base Valve Assy Fig 9-10r01
 Cable Crane-Base Valve Assy Fig 9-10
 Cable Crane-Control Valve Assy Fig 9-11
 Crane Base Lift Cylinder Assy Fig 9-12

Water Assy-Section 10

Water Line Assy Fig 10-1r01
 Water Line Assy Fig 10-1
 Water-Hammer Union Components-3" Fig 10-2
 Dump Valve Assy Fig 10-3

Safety Assy - Section 11

Safety-Voltage Stake Assy Fig 11-1r01
 Safety-Voltage Stake Assy Fig 11-1
 Safety Features-Gloves Boots Cones Fig 11-2

Component Assy - Section 12

Components-Valve-Crane Control Fig 12-1r01
 Components-Valve-Crane Control Fig 12-1
 Component-Hyd-Valve Relief Fig 12-2
 Component-Hyd-Valve Diverter Fig 12-3
 Component-Hyd-Valve Directional Fig 12-4
 Component-Hyd-Valve High Speed Fig 12-5
 Component-Hyd-Valve 3 Speed Flush Fig 12-6
 Component-Hyd-Valve Crane Base Fig 12-7
 Component-Hyd-Valve Heater/Cooler Manifold Fig 12-8
 Component-Hyd-Valve Bleeder Fig 12-9
 Component-Hyd-Pump Fan Fig 12-10
 Component-Hyd-Pump Ground Drive/Thrust Fig 12-11
 Component-Hyd-Pump Rotation Fig 12-12
 Component-Hyd-Cylinder Crane Base Fig 12-13
 Component-Hyd-Cylinder Crane Base Lock Fig 12-14
 Component-Hyd-Valve Catwalk Multifunction Fig 12-15
 Component-Hyd-Cylinder Fig 12-16
 Component-Hyd-Cylinder Fig 12-17
 Component-Hyd-Cylinder Rack Pivot Fig 12-18
 Component-Hyd-Cylinder Lower Boom Fig 12-19
 Component-Hyd-Cylinder Extension Boom Fig 12-20
 Component-Track Roller Fig 12-21
 Component-Track Drive Gearbox Fig 12-22
 Component-Idler Roller Fig 12-23
 Component-Air Conditioner/Heater Fig 12-24
 Component-Pump Drive (Not Available) Fig 12-25r01
 Component-Pump Drive Fig 12-25
 Component- Joystick Fig 12-26
 Component-Seat Control Fig 12-27
 Component-Air Cleaner Fig 12-28
 Component- Oil Filter Fig 12-29
 Components-Hose Carrier Fig 12-30r01
 Components-Hose Carrier Fig 12-30
 Component-Hose Carrier Fig 12-31
 Component-Hose Carrier Fig 12-32
 Component-Floating Cushion Sub Fig 12-33
 Component-Water Swivel Fig 12-34
 Component-Motor-Thrust/Pullback W/Brake Fig 12-35
 Component-Motor-Thrust/Pullback WO/Brake Fig 12-36
 Component-Motor-Rotation W/Brake Fig 12-37
 Component-Motor-Rotation W/Brake (Continued) Fig 12-37
 Component-Motor-Rotation WO/Brake Fig 12-38
 Components-Vise Assy Fig 12-39
 Component-Upper Jaw/Lower Jaw/Piston Jaw Assy Fig 12-40
 Component-Gearbox Fig 12-41
 Component-Hyd Cylinder Fig 12-42
 Component-Hyd Cylinder Fig 12-43r01

Component-Hyd Cylinder Fig 12-43
 Component-Hyd Valve-Scissor Vise Lift Fig 12-44
 Component-Valve Scissor Vise Fig 12-45r01
 Component-Valve Scissor Vise Fig 12-45
 Component-Hyd Cylinder Fig 12-46r01
 Component-Hyd Cylinder Fig 12-46
 Component-Hyd Motor-Vise Fig 12-47
 Component-Hyd Motor Fig 12-48
 Component-Water Shut-Off Valve Fig 12-49
 Component-Hyd Cylinder Fig 12-50
 Component-Hyd Cylinder Fig 12-51
 Component-Hyd Tension Valve Fig 12-52

Diagram - Hyd Locations Assy - Section 13

Diagram-Hyd Location-Crane Base Lift Fig 13-1r02
 Diagram-Hyd Location-Crane Base Lift Fig 13-1r01
 Diagram-Hyd Location-Crane Base Lift Fig 13-1
 Diagram-Hyd Location-Ground Drive/Pullback Pump Fig 13-2r02
 Diagram-Hyd Location-Ground Drive/Pullback Pump Fig 13-2r01
 Diagram-Hyd Location-Ground Drive/Pullback Pump Fig 13-2
 Diagram-Hyd Location-Thrust/Pullback Motors Fig 13-3r01
 Diagram-Hyd Location-Thrust/Pullback Motors Fig 13-3
 Diagram-Hyd Location-Rotation Gearbox Fig 13-4
 Diagram-Hyd Location-Ground Drive Fig 13-5r01
 Diagram-Hyd Location-Ground Drive Fig 13-5
 Diagram Hyd Location-Catwalk/Handrail Fig 13-6r01
 Diagram Hyd Location-Catwalk/Handrail Fig 13-6
 Diagram Hyd Location-Fan Motor Fig 13-7r01
 Diagram Hyd Location-Fan Motor Fig 13-7
 Diagram-Hyd Location Vise Rear Fig 13-8r01
 Diagram-Hyd Location Vise Rear Fig 13-8
 Diagram-Hyd Location Vise Front Fig 13-9
 Diagram-Hyd Location Triple Stack Pump/Oil Cooler. Fig 13-10r01
 Diagram-Hyd Location Triple Stack Pump/Oil Cooler. Fig 13-10
 Diagram-Hyd Location Track Tension Valve/Cylinder Fig 13-11
 Diagram-Hyd Location Cold Start. Fig 13-12

This page intentionally left blank.

Decal Assy-Domestic Fig 1-1r01

DELETED DUE TO UPDATE

Decal Assy-Domestic Fig 1-1r01

REF. NO.	*	PART NO.	DESCRIPTION	QTY.	REMARKS
		Revision Date	June, 2002		Deleted Due To Update

Decal Assy-Domestic Fig 1-1

D150x300 Vermeer

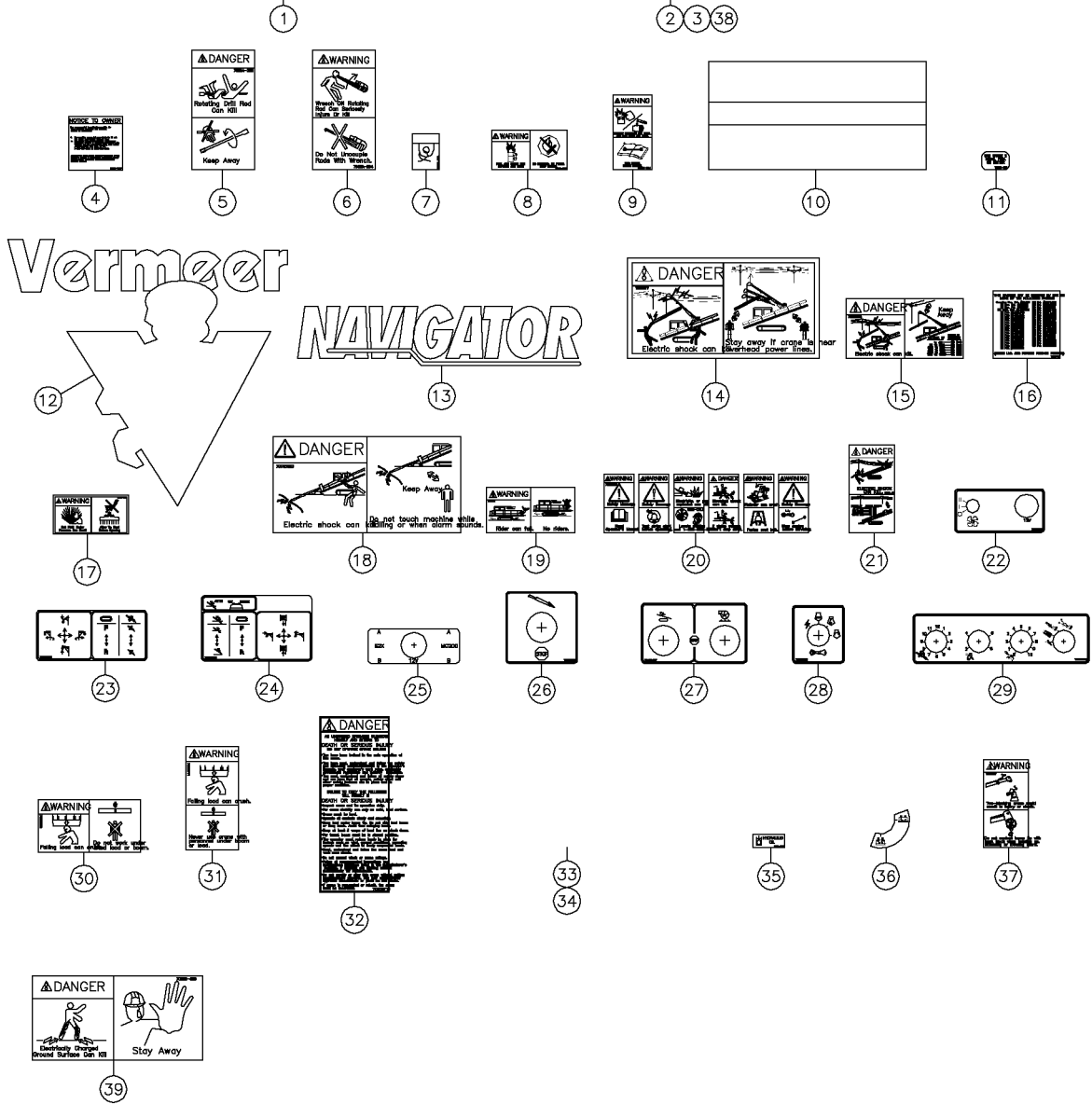

Decal Assy-Domestic Fig 1-1

REF. NO.	*	PART NO.	DESCRIPTION	QTY.	REMARKS
1		7000B411	DECAL - MODEL NUBMER - D150 X 300	1	
2		7000B276	DECAL - 6" VERMEER	1	
3		7000A557	VERMEER DECAL	2	
4		2326940	DECAL-NOTICE TO OWNERS	1	
5		7000A393	DECAL - DANGER	4	
6		7000A394	DECAL - WARNING	2	
7		7000I834	DECAL - TIE DOWN POINT	6	
8		2326324	DECAL-WARNING/REFUEL	1	
9		70000044	DECAL-WARNING(AT/UND)	1	
10		70000777	DECAL 6"VERMEER STRIPE	A/R	P/N Qty of 1 = 1 Foot, Req's 25 Feet
11		70000098	DECAL-DIESEL (AT/UND)	1	
12		70000940	DECAL-20" VERMEER LOGO	2	
13		70000614	DECAL-MODEL NAVIGATOR (BIG)	2	
14		7000B617	DECAL - DANGER POWER LINES	5	
15		7000B624	DECAL - DANGER KEEP AWAY	1	
16		7000B119	DECAL - PATENT	1	
17		2326315	DECAL-WARNING	1	
18		7000B623	DECAL - DANGER ELECTRIC SHOCK	6	
19		7000B622	DECAL - WARNING NO RIDERS	1	
20		7000B621	DECAL - WARNING LAUNDRY LIST	1	
21		7000A971	DECAL - DANGER	1	
22		700IB614	DECAL - OVERHEAD CONTROLS	1	
23		700IB613	DECAL - LEFT JOYSTICK	1	
24		700IB612	DECAL - RIGHT JOYSTICK	1	
25		700IB410	DECAL - POWER POINT	1	
26		700IB656	DECAL - E-STOP DRILLING OPERATION	1	
27		700IB407	DECAL - EMERGENCY STOP	1	
28		700IB408	DECAL - IGNITION	1	
29		700IB409	DECAL - AUTO STEERING	1	
30		7000B702	DECAL - DANGER - FALLING LOAD	1	
31		7000B711	DECAL - WARNING - FALLING LOAD	1	
32		7000B712	DECAL - DANGER	1	
33		296264801	DECAL-CAPACITY CHART 7.5 X 5.5	1	
34		296264802	DECAL-CAPACITY CHART 8.25 X 12	1	
35		2326756	DECAL-HYDRAULIC OIL	1	
36		700IA695	DECAL-BATTERY DISCONNECT	1	
37		7000B667	DECAL - DANGER	1	
38		70000803	DECAL-VERMEER 8 1/2	1	
39		70000530	DECAL-DANGER	1	
		901228153	Decal Assembly - D150x300 (Domestic)		

Decal Assy-Domestic Fig 1-1x01r01

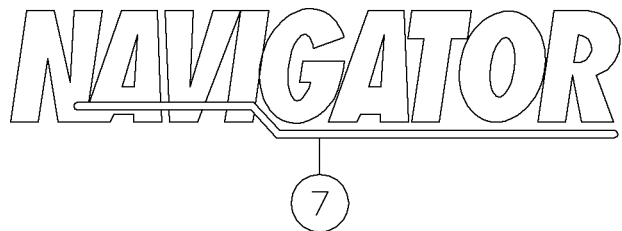
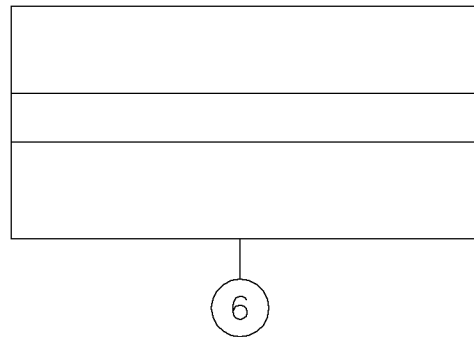
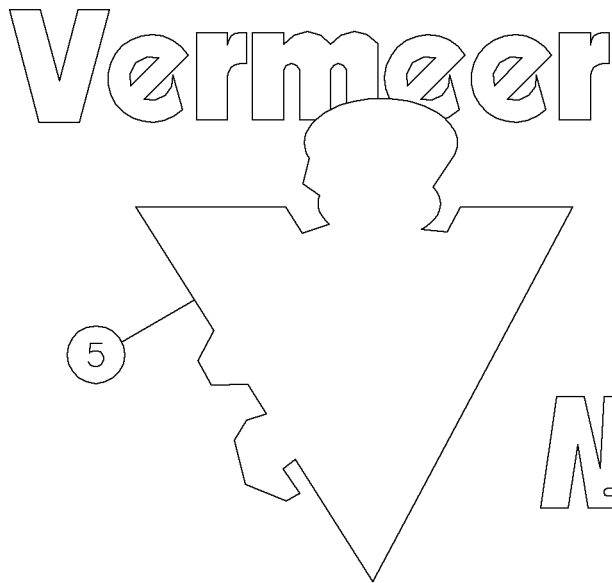
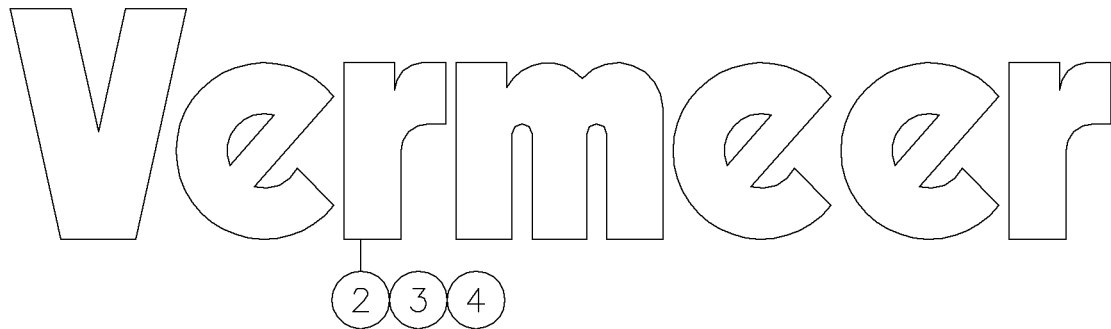
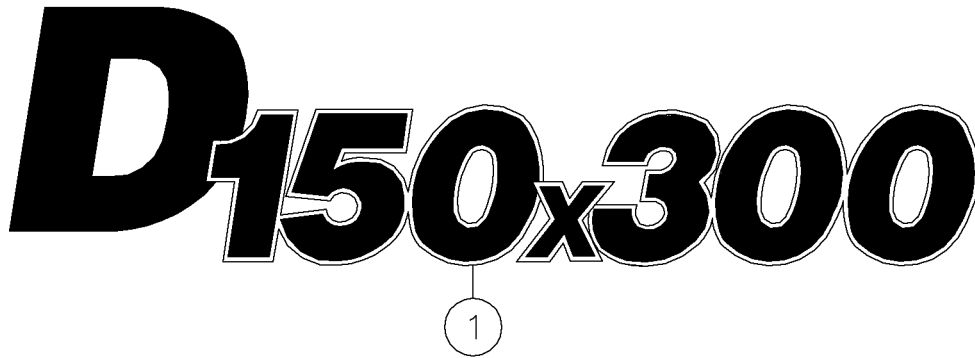

Decal Assy-Domestic Fig 1-1x01r01

REF. NO.	*	PART NO.	DESCRIPTION	QTY.	REMARKS
		Revision Date	October, 2004		Update In Illustration & Parts List.
1		7000B411	DECAL - MODEL NUBMER - D150 X 300	1	
2		7000B276	DECAL - 6" VERMEER	1	
3		7000A557	VERMEER DECAL	2	
4		70000803	DECAL-VERMEER 8 1/2	1	
5		70000940	DECAL-20" VERMEER LOGO	2	
6		70000777	DECAL 6"VERMEER STRIPE	25 Ft	
7		70000614	DECAL-MODEL NAVIGATOR (BIG)	2	
		901228153	DECAL ASSY - D150X300 DOMESTIC		Inc 1-1xo1-1-1x05

Decal Assy-Domestic Fig 1-1x01



Decal Assy-Domestic Fig 1-1x01

REF. NO.	*	PART NO.	DESCRIPTION	QTY.	REMARKS
1		7000B411	DECAL - MODEL NUBMER - D150 X 300	1	
2		7000B276	DECAL - 6" VERMEER	1	
3		7000A557	VERMEER DECAL	2	
4		70000803	DECAL-VERMEER 8 1/2	1	
5		70000940	DECAL-20" VERMEER LOGO	2	
6		70000777	DECAL 6"VERMEER STRIPE	25 Ft	
7		70000614	DECAL-MODEL NAVIGATOR (BIG)	2	
8		901228153	DECAL ASSY - D150X300 DOMESTIC		Inc 1-1x01-1-1x05

Decal Assy-Domestic Fig 1-1x02r01



Decal Assy-Domestic Fig 1-1x02r01

REF. NO.	*	PART NO.	DESCRIPTION	QTY.	REMARKS
		Revision Date	October, 2004		Update In Illustration & Parts List.
1		7000A393	DECAL - DANGER	4	
2		7000A394	DECAL - WARNING	2	
3		70000044	DECAL-WARNING(AT/UND)	1	
4		7000A971	DECAL - DANGER	1	
5		7000B811	DECAL - DANGER - RLE - DOMESTIC	3	
6		7000B624	DECAL - DANGER KEEP AWAY	1	
7		7000B711	DECAL - WARNING - FALLING LOAD	1	
8		7000B667	DECAL - DANGER	1	
9		2326315	DECAL-WARNING	1	
10		70000530	DECAL-DANGER	1	
11		2326324	DECAL-WARNING/REFUEL	1	
		901228153	DECAL ASSEMBLY D150X300(DOMESTIC)		Inc Fig 1-1x01-1-1x05

Decal Assy-Domestic Fig 1-1x02



Decal Assy-Domestic Fig 1-1x02

REF. NO.	*	PART NO.	DESCRIPTION	QTY.	REMARKS
1		7000A393	DECAL - DANGER	4	
2		7000A394	DECAL - WARNING	2	
3		70000044	DECAL-WARNING(AT/UND)	1	
4		7000A971	DECAL - DANGER	1	
5		7000B811	DECAL - DANGER - RLE - DOMESTIC	3	
6		7000B624	DECAL - DANGER KEEP AWAY	1	
7		7000B711	DECAL - WARNING - FALLING LOAD	1	
8		7000B667	DECAL - DANGER	1	
9		2326315	DECAL-WARNING	1	
10		2326324	DECAL-WARNING/REFUEL	1	
11		7000B702	DECAL - DANGER - FALLING LOAD	1	
12		70000530	DECAL-DANGER	1	
13		901228153	DECAL ASSY-D150X300 DOMESTIC	1	Inc Fig 1-1x01 Thru Fig 1-1x05

Decal Assy-Domestic Fig 1-1x03r01

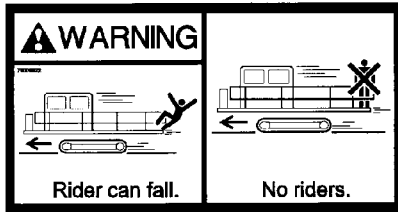

1

3

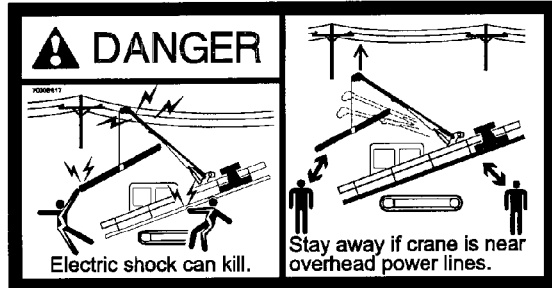

2

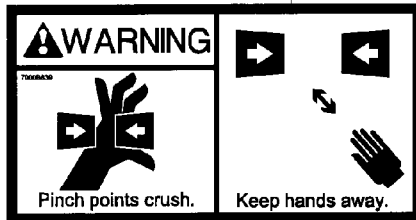

4

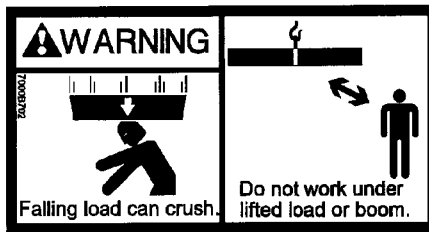

5

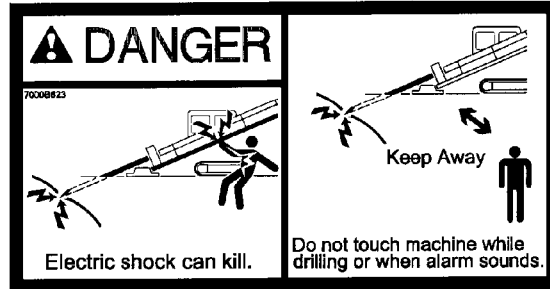

6

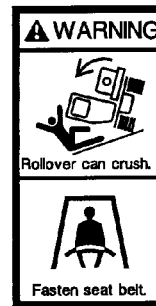
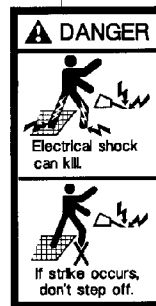
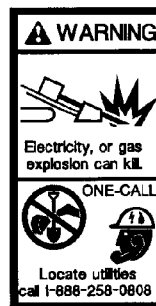

Decal Assy-Domestic Fig 1-1x03r01

REF. NO.	*	PART NO.	DESCRIPTION	QTY.	REMARKS
		Revision Date	October, 2004		Update In Illustration & Parts List.
1		7000B622	DECAL - WARNING NO RIDERS	1	
2		7000B617	DECAL - DANGER POWER LINES	5	
3		7000B839	DECAL - WARNING	2	
4		7000B623	DECAL - DANGER ELECTRIC SHOCK	6	
5		7000B702	DECAL - DANGER - FALLING LOAD	1	
6		7000B621	DECAL - WARNING LAUNDRY LIST	1	
		901228153	DECAL ASSEMBLY D150X300(DOMESTIC)		Inc Fig 1-1x01-1-1x05

Decal Assy-Domestic Fig 1-1x03

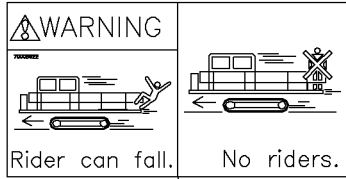

1

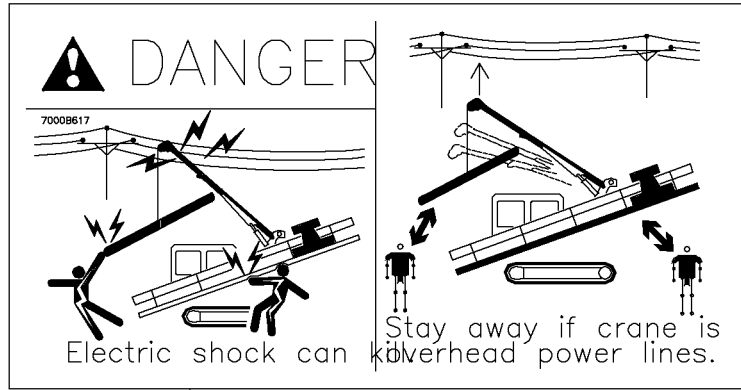

2

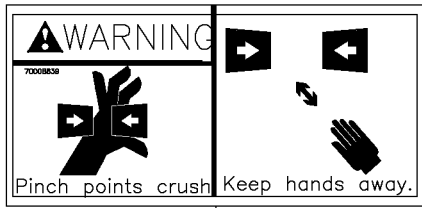

3

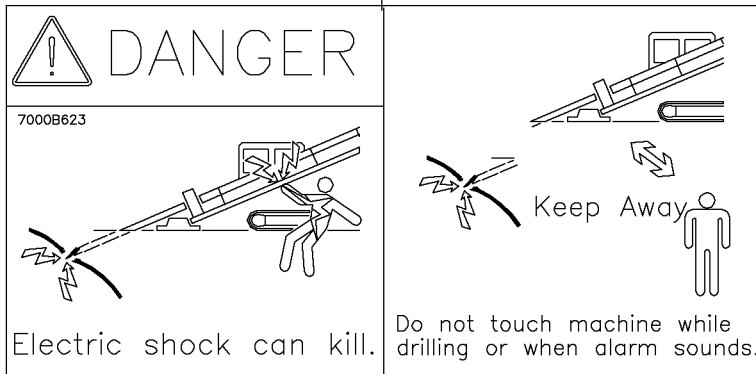

4

5

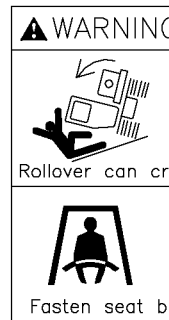
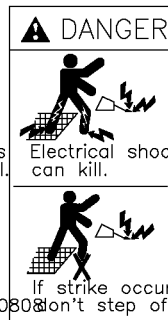
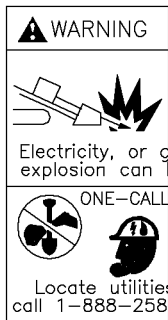
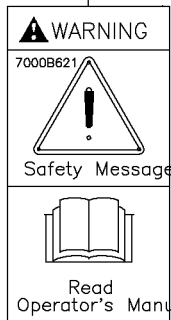

6

Decal Assy-Domestic Fig 1-1x03

REF. NO.	*	PART NO.	DESCRIPTION	QTY.	REMARKS
1		7000B622	DECAL - WARNING NO RIDERS	1	
2		7000B617	DECAL - DANGER POWER LINES	5	
3		7000B839	DECAL - WARNING	2	
4		7000B623	DECAL - DANGER ELECTRIC SHOCK	6	
5		7000B621	DECAL - WARNING LAUNDRY LIST	1	
6		901228153	DECAL ASSY-D150X300 DOMESTIC	1	Inc Fig 1-1x01 Thru 1-1x05

Decal Assy-Domestic Fig 1-1x04r01

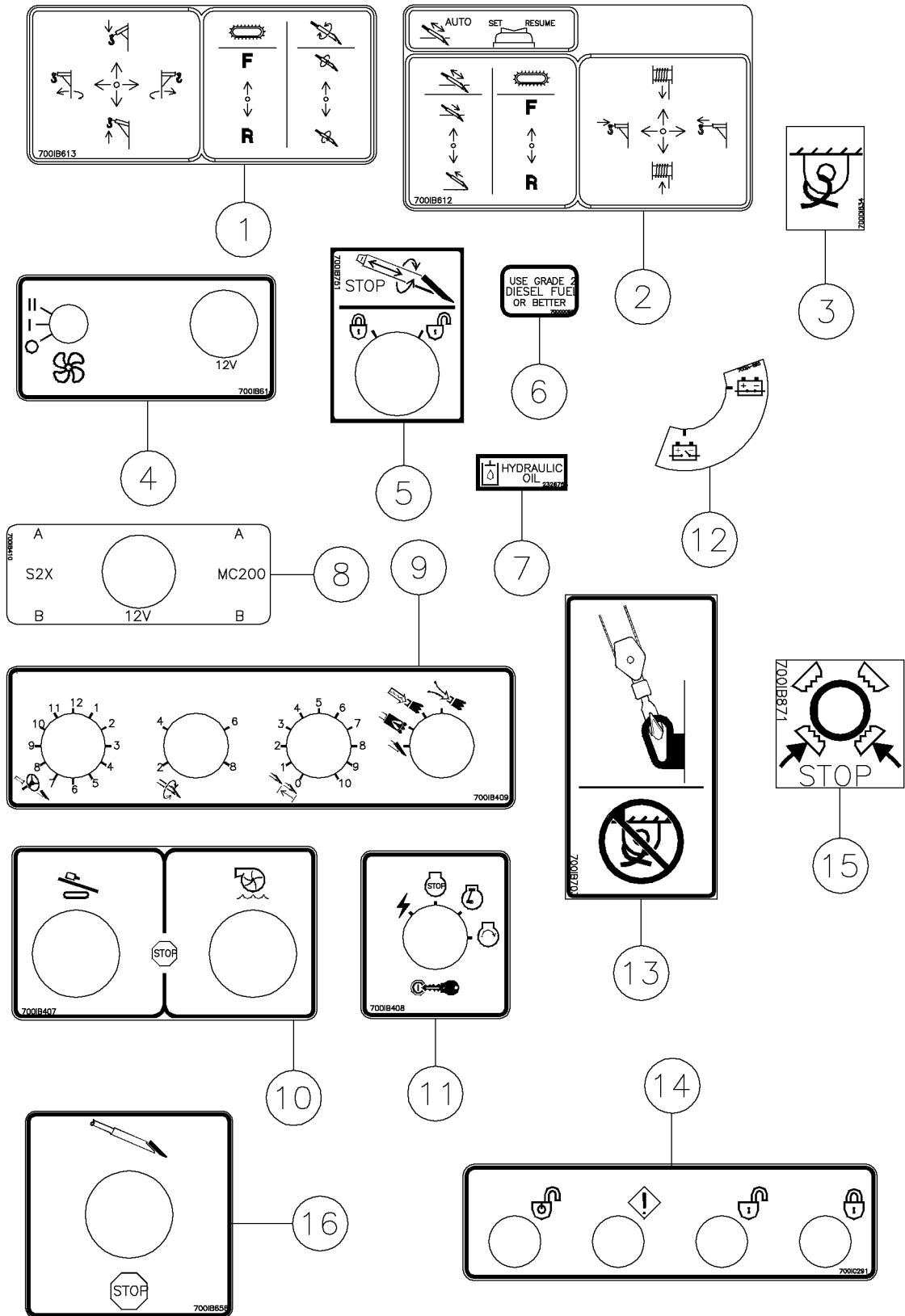

Decal Assy-Domestic Fig 1-1x04r01

REF. NO.	*	PART NO.	DESCRIPTION	QTY.	REMARKS
		Revision Date	October, 2004		Update In Illustration & Parts List.
1		700IB613	DECAL - LEFT JOYSTICK	1	
2		700IB612	DECAL - RIGHT JOYSTICK	1	
3		7000I834	DECAL - TIE DOWN POINT	7	
4		700IB614	DECAL - OVERHEAD CONTROLS	1	
5		700IB751	DECAL - LOCKOUT	2	
6		70000098	DECAL-DIESEL (AT/UND)	1	
7		2326756	DECAL-HYDRAULIC OIL	1	
8		700IB410	DECAL - POWER POINT	1	
9		700IB409	DECAL - AUTO STEERING	1	
10		700IB407	DECAL - EMERGENCY STOP	1	
11		700IB408	DECAL - IGNITION	1	
12		700IA695	DECAL-BATTERY DISCONNECT	1	
13		700IB703	DECAL - HOOK	1	
14		700IC291	DECAL - REMOTE LOCKOUT	1	
15		700IB871	DECAL - VISE BUTTON	2	
16		700IB656	DECAL - E-STOP DRILLING OPERATION	1	
		901228153	DECAL ASSEMBLY D150X300(DOMESTIC)		Inc Fig 1-1x01Thru 1-1x05

Decal Assy-Domestic Fig 1-1x04

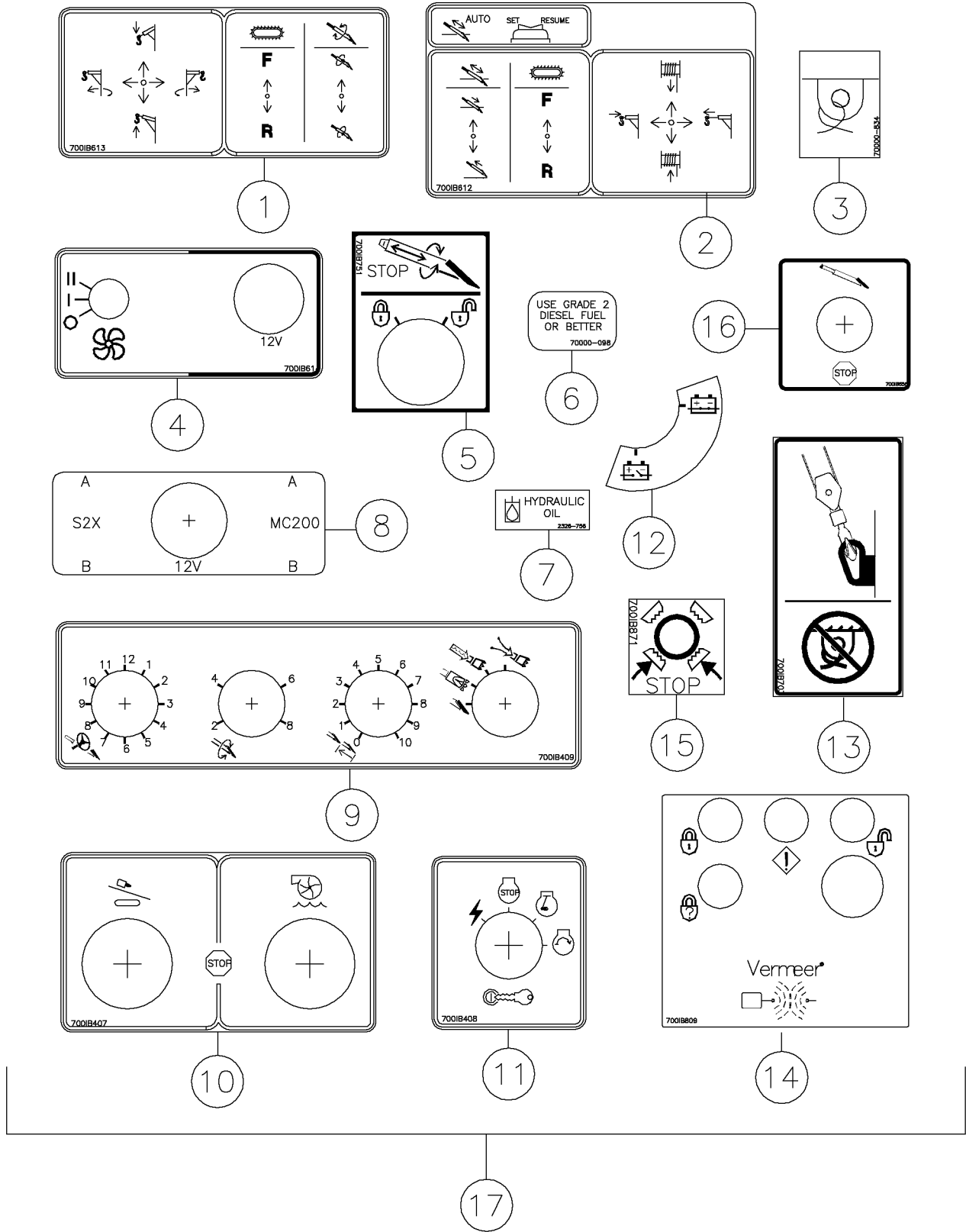

Decal Assy-Domestic Fig 1-1x04

REF. NO.	*	PART NO.	DESCRIPTION	QTY.	REMARKS
1		700IB613	DECAL - LEFT JOYSTICK	1	
2		700IB612	DECAL - RIGHT JOYSTICK	1	
3		7000I834	DECAL - TIE DOWN POINT	7	
4		700IB614	DECAL - OVERHEAD CONTROLS	1	
5		700IB751	DECAL - LOCKOUT	2	
6		70000098	DECAL-DIESEL (AT/UND)	1	
7		2326756	DECAL-HYDRAULIC OIL	1	
8		700IB410	DECAL - POWER POINT	1	
9		700IB409	DECAL - AUTO STEERING	1	
10		700IB407	DECAL - EMERGENCY STOP	1	
11		700IB408	DECAL - IGNITION	1	
12		700IA695	DECAL-BATTERY DISCONNECT	1	
13		700IB703	DECAL - HOOK	1	
14		700IB809	DECAL - REMOTE LOCKOUT	1	
15		700IB871	DECAL - VISE BUTTON	2	
16		700IB656	DECAL - E-STOP DRILLING OPERATION	1	
17		901228153	DECAL ASSY-D150X300 DOMESTIC	1	Inc Fig 1-1x01 Thru Fig 1-1x05

Decal Assy-Domestic Fig 1-1x05r01

⚠ DANGER

AN UNTRAINED OPERATOR SUBJECTS HIMSELF AND OTHERS TO DEATH OR SERIOUS INJURY DO NOT OPERATE CRANE UNLESS

- You have been trained in the safe operation of this crane.
- You have read, understand and follow the safety and operating recommendations in the Operator's Manual, your employer's work rules, applicable government regulations, and industry standards.
- You have read, understand and follow all safety signs and are sure that all guards, safety signs and other safety features are in place and in proper condition.

FAILURE TO OBEY THE FOLLOWING WILL RESULT IN DEATH OR SERIOUS INJURY

- Inspect crane and its operation daily.
- For crane stability use only on solid, level surface.
- Crane must be level.
- Operate all controls slowly and smoothly.
- Keep load under boom tip. Do not slide load boom or drag loads. Avoid free-swinging loads.
- Keep at least 3 wraps of load line on which drum.
- For travel, boom must be in stowed position.
- The operator must reduce loads to allow for factors such as wind, ground conditions, operating speeds and the effect of freely suspended loads.
- Read, understand, and follow the crane load and work area charts.
- Do not exceed winch or crane ratings.
- Follow all recommended inspections and maintenance practices listed in the manufacturer's manuals. If manuals are missing contact manufacturer for replacement.
- Do not modify or alter this crane without written manufacturer's approval. Use only manufacturer approved attachments or parts on this crane.
- If crane is remounted or rebuilt, the crane must be recertified.

7000B712

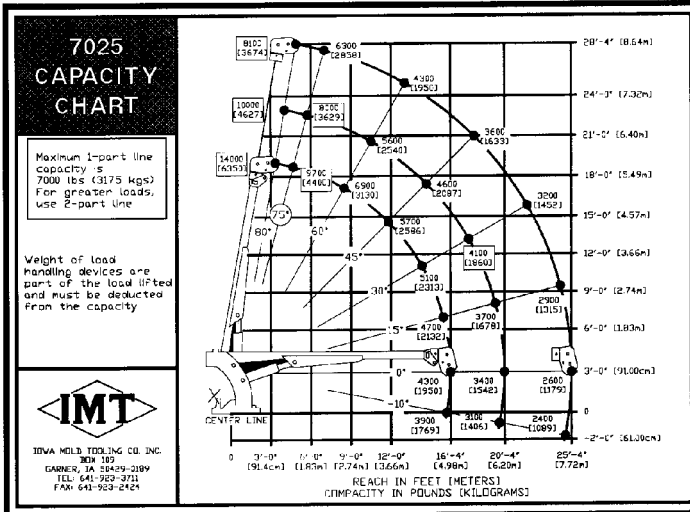

This product may be covered by one or more of the following patents:

AU 758,936	US 6,660,041	US 6,196,822	US 6,477,795
CA D 78,593	US 6,607,280	US 6,247,544	US 6,484,818
DE 686 11 848	US 5,811,496	US 6,289,997	US 6,491,116
DE 202 14 989.8	US 5,867,803	US 6,306,787	US 6,497,296
DE Des. 98 006 85.4	US 5,859,985	US 6,315,922	US 6,511,280
EP 772,543	US 5,887,807	US 6,332,502	US 6,516,899
EP 830,522	US 5,892,548	US 6,357,537	US 6,517,733
EP 885,343	US 5,892,549	US 6,360,830	US 6,533,048
EP 1,153,194	US 5,704,142	US 6,367,594	US 6,533,052
GB 2,053,838	US 5,720,354	US 6,374,928	US 6,554,082
HK 1015859	US 5,746,278	US 6,382,330	US 6,557,851
RU 2,158,952	US 6,768,811	US 6,389,380	US 6,577,954
US Des. 366,882	US 5,778,991	US 6,390,207	US 6,588,062
US Des. 366,837	US 5,819,859	US 6,406,952	US 6,589,516
US 4,846,423	US 5,846,589	US 6,406,954	US 6,591,735
US 5,205,181	US 5,804,210	US 6,412,715	US 6,599,202
US 5,219,380	US 5,844,121	US 6,422,495	US 6,599,948
US 5,237,898	US 5,950,942	US 6,435,298	US 6,594,538
US 5,291,964	US 6,014,998	US 6,439,319	US 6,701,647
US 5,538,220	US 6,050,350	US 6,445,385	US 6,719,099
US 5,544,055	US 6,109,387	US 6,446,889	US 6,725,579
US 5,565,407	US 6,119,376	US 6,454,025	US 6,729,050
US 5,558,253	US 6,138,932	US 6,470,878	
US 5,574,642	US 6,154,987	US 6,474,931	
US 5,588,474	US 6,161,830	US 6,474,932	

This product may be covered by one or more of the following licensed patents:

US 4,684,913	US 4,867,255	US 5,148,890
US 4,868,704	US 4,953,638	US 5,799,740

(OTHER U.S. AND FOREIGN PATENTS PENDING)

Notice • Avis • Hinweis • Avviso • Aviso

If you purchased this product as used equipment, you can receive a FREE Operator's Manual by contacting:

Si vous avez acheté cet équipement d'occasion, vous pouvez recevoir un manuel de l'opérateur GRATUIT en composant le:

Wenn Sie diese Maschine gebraucht erworben haben, können Sie eine KOSTENLOSE Betriebsanleitung wie folgt anfordern:

Se si è comprata la presente macchina usata, si può ricevere una copia del manuale dell'operatore IN OMAGGIO, contattando:

Si este producto que ha comprado es un equipo usado, puede recibir un manual del operador GRATUITO llamando al:

Vermeer Manufacturing Company
ATTN: Customer Data Department
1210 Vermeer Road East, PO BOX 200
Pella, IA 50219 USA
800-828-0061 or 641-629-3141
Telephone: English speaking only
Téléphone: en anglais uniquement
Telefon: Nur in Englischer Sprache
Telefono: tutte le comunicazioni saranno in Inglese
Telefono: en Inglés solamente

OR by completing and mailing the Used Equipment Registration Form enclosed in the Operator's Manual. OU en remplissant et en envoyant le formulaire d'enregistrement de l'équipement d'occasion inclus dans le manuel de l'opérateur. ODER das in der Betriebsanleitung enthaltene Formular zur Registrierung gebrauchter Ausrüstung ausfüllen und einsenden. OPPURE compilando e spedendo il modulo di registrazione per macchinari usati, incluso al manuale dell'operatore. O rellenando y enviando por correo el impreso de registro de equipos usados incluido en el manual del operador.

Decal Assy-Domestic Fig 1-1x05r01

REF. NO.	*	PART NO.	DESCRIPTION	QTY.	REMARKS
		Revision Date	October, 2004		Update In Illustration & Parts List.
1		7000B712	DECAL - DANGER	1	
2		296264801	DECAL - CAPACITY CHART 7.5 X 5.5	1	
3		296264802	DECAL - CAPACITY CHART 8.25 X 12	1	
4		2326940	DECAL-NOTICE TO OWNERS	1	
5		7000B119	DECAL - PATENT INDUSTRIAL	1	
		901228153	DECAL ASSEMBLY D150X300(DOMESTIC)		Inc Fig 1-1x01 Thru 1-1x05

Decal Assy-Domestic Fig 1-1x05

DANGER

AN UNTRAINED OPERATOR SUBJECTS HIMSELF AND OTHERS TO DEATH OR SERIOUS INJURY DO NOT OPERATE CRANE UNLESS

- You have been trained in the safe operation of this crane.
- You have read, understand and follow the safety and operating recommendations in the Operator's Manuals, your employer's work rules, applicable government regulations and industry standards.
- You read, understand and follow all safety signs and are sure that all guards, safety signs and other safety features are in place and in proper condition.

FAILURE TO OBEY THE FOLLOWING WILL RESULT IN DEATH OR SERIOUS INJURY

- Inspect crane and its operation daily.
- For crane stability use only on solid, level surface.
- Crane must be level.
- Operate all controls slowly and smoothly.
- Keep load under boom tip. Do not side load boom or drag loads. Avoid free swinging loads.
- Keep at least 3 wraps of load line on winch drum.
- For travel, boom must be in stowed position.
- The operator must reduce loads to allow for factors such as wind, ground conditions, operating speeds and the effect of freely suspended loads.
- Read, understand and follow the crane load and work area charts.
- Do not exceed winch or crane ratings.
- Follow all recommended inspections and maintenance practices listed in the manufacturer's manuals. If manuals are missing contact manufacturer for replacement.
- Do not modify or alter this crane without written manufacturer's approval. Use only manufacturer approved attachments or parts on this crane.
- If crane is remounted or rebuilt, the crane must be recertified.

7000B712

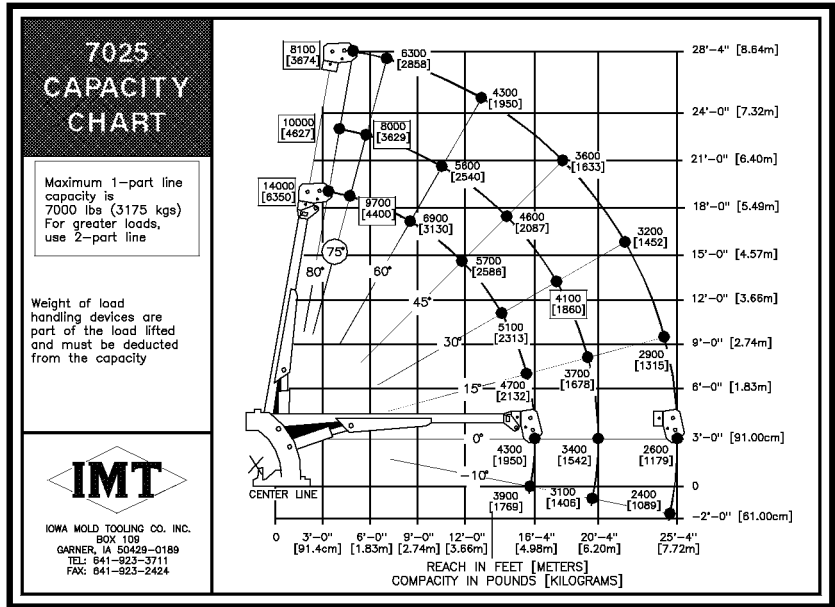

NOTICE TO OWNER

You are requested to notify Vermeer Mfg. Co when you have purchased this machine.

Methods of Notification:

1. New machine owner: Ask your dealer to fill out and return your Limited Warranty Card.
2. Pre-owned machine owner: Send in Customer Data Card (located in operator's manual) or write Vermeer Mfg. Co. at Box 200, Pella, Iowa 50219 ATTN: Customer Data Dept. or call 1-800-829-0051 or (515) 628-3141.

An owner of a pre-owned machine will receive a free operator's manual if requested (1 per owner). A new machine owner will receive an operator's manual with the machine.

2326-940

This product may be covered by one or more of the following patents:

CA D 79,593	US 5,219,380	US 5,704,142	US 6,247,544
CC 95 914 404.5	US 5,237,888	US 5,720,354	US 6,289,997
CC ZL96195734.4	US 5,291,964	US 5,746,278	US 6,290,155
DE 696 11 846	US 5,394,583	US 5,768,811	US 6,308,787
DE Des. 96 006 85.4	US 5,507,441	US 5,778,991	US 6,315,062
EP 772,543	US 5,509,220	US 5,819,859	US 6,332,502
EP 885,343	US 5,544,055	US 5,845,689	US 6,357,537
GB 2,053,636	US 5,553,407	US 5,904,210	US 6,360,830
HK 1015859	US 5,556,253	US 5,941,320	US 6,367,564
RU 2,141,907	US 5,574,642	US 5,944,121	US 6,374,928
RU 2,158,952	US 5,588,474	US 5,950,942	US 6,382,330
RU 2,163,963	US 5,590,041	US 6,014,996	US 6,389,360
RU 2,175,368	US 5,607,280	US 6,050,350	
US Des. 308,682	US 5,611,496	US 6,109,367	
US Des. 396,837	US 5,657,803	US 6,119,376	
US 4,848,423	US 5,659,985	US 6,138,932	
US 5,074,063	US 5,687,807	US 6,154,987	
US 5,088,532	US 5,692,548	US 6,161,630	
US 5,205,181	US 5,692,549	US 6,195,922	

This product may be covered by one or more of the following licensed patents:

US 4,694,913	US 4,867,255	US 5,148,880
US 4,858,704	US 4,953,638	US 5,799,740

(OTHER U.S. AND FOREIGN PATENTS PENDING)

Decal Assy-Domestic Fig 1-1x05

REF. NO.	*	PART NO.	DESCRIPTION	QTY.	REMARKS
1		7000B712	DECAL - DANGER	1	
2		296264801	DECAL - CAPACITY CHART 7.5 X 5.5	1	
3		296264802	DECAL - CAPACITY CHART 8.25 X 12	1	
4		2326940	DECAL-NOTICE TO OWNERS	1	
5		7000B119	DECAL - PATENT	1	
6		901228153	DECAL ASSY-D150X300 DOMESTIC	1	Inc Fig 1-1x01 Thru Fig 1-1x05

Decal Assy-International Fig 1-2r01

DELETED DUE TO UPDATE

Decal Assy-International Fig 1-2r01

REF. NO.	*	PART NO.	DESCRIPTION	QTY.	REMARKS
		Revision Date	June, 2002		Delete Figure Due To Update
			Fig 1-2r01		

Decal Assy-International Fig 1-2

D150x300 Vermeer

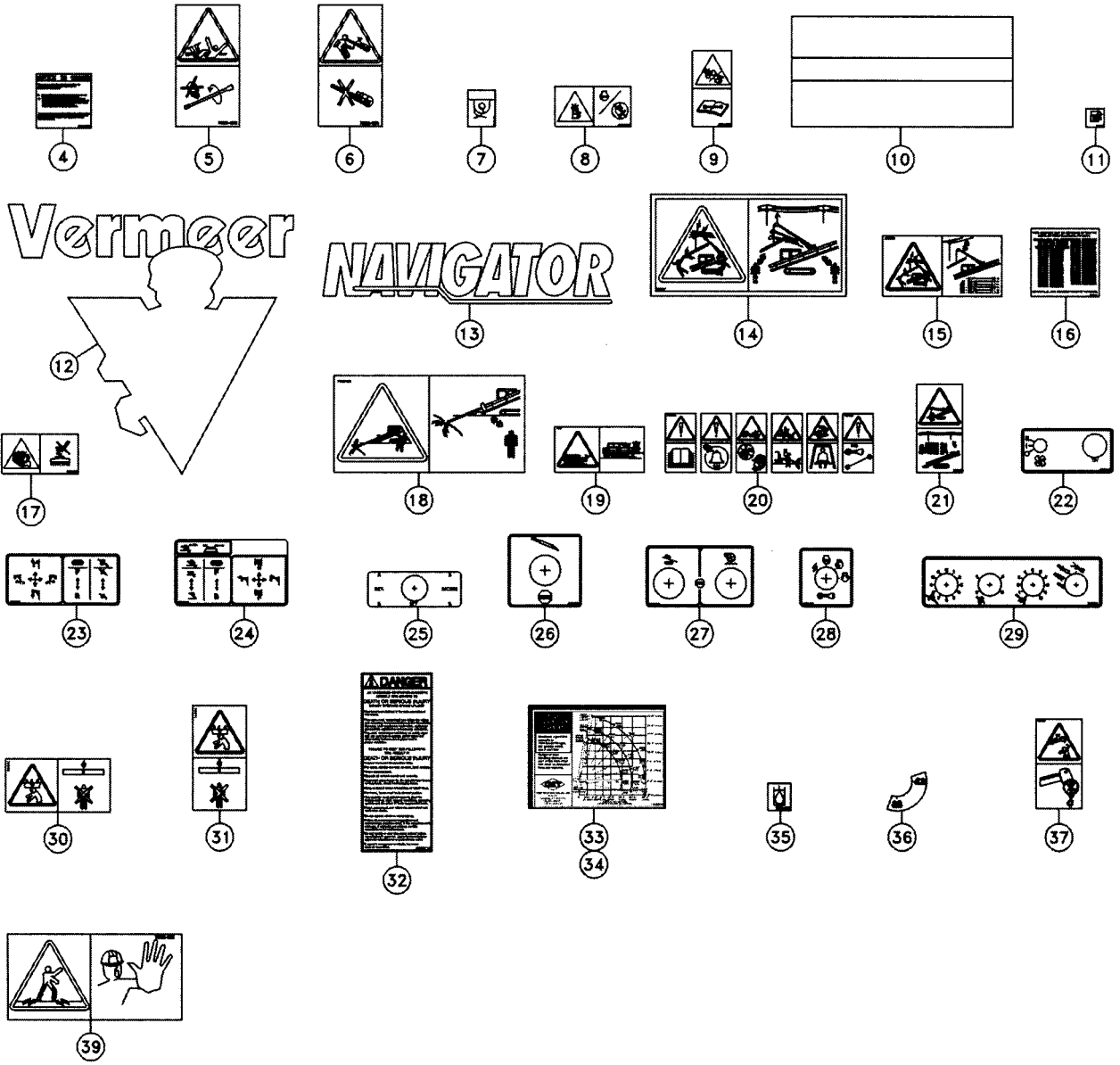

Decal Assy-International Fig 1-2

REF. NO.	*	PART NO.	DESCRIPTION	QTY.	REMARKS
1		7000B411	DECAL - MODEL NUBMER - D150 X 300	1	
2		7000B276	DECAL - 6" VERMEER	1	
3		7000A557	VERMEER DECAL	2	
4		2326940	DECAL-NOTICE TO OWNERS	1	
5		700IA393	DECAL - DANGER	4	
6		700IA394	DECAL - WARNING	2	
7		7000I834	DECAL - TIE DOWN POINT	6	
8		2326I324	DECAL-WARNING	1	
9		7000I044	DECAL-WARNING	1	
10		70000777	DECAL 6"VERMEER STRIPE	A/R	P/N Qty of 1 = 1 Foot - Req's 25 Feet
11		7000I098	DECAL-DIESEL FUEL	1	
12		70000940	DECAL-20" VERMEER LOGO	2	
13		70000614	DECAL-MODEL NAVIGATOR (BIG)	2	
14		700IB617	DECAL - DANGER POWER LINES	5	
15		700IB624	DECAL - DANGER KEEP AWAY	1	
16		7000B119	DECAL - PATENT	1	
17		2326I315	DECAL-WARNING	1	
18		700IB623	DECAL - DANGER ELECTRIC SHOCK	6	
19		700IB622	DECAL - WARNING NO RIDERS	1	
20		700IB621	DECAL - WARNING LAUNDRY LIST	1	
21		700IA971	DECAL-DANGER	1	
22		700IB614	DECAL - OVERHEAD CONTROLS	1	
23		700IB613	DECAL - LEFT JOYSTICK	1	
24		700IB612	DECAL - RIGHT JOYSTICK	1	
25		700IB410	DECAL - POWER POINT	1	
26		700IB656	DECAL - E-STOP DRILLING OPERATION	1	
27		700IB407	DECAL - EMERGENCY STOP	1	
28		700IB408	DECAL - IGNITION	1	
29		700IB409	DECAL - AUTO STEERING	1	
30		700IB702	DECAL - DANGER - FALLING LOAD	1	
31		700IB711	DECAL - WARNING - FALLING LOAD	1	
32		7000B712	DECAL - DANGER	1	
33		296264801	DECAL-CAPACITY CHART 7.5 X 5.5	1	
34		296264802	DECAL-CAPACITY CHART 8.25 X 12	1	
35		2326I756	DECAL-HYDRAULIC FLUID	1	
36		700IA695	DECAL-BATTERY DISCONNECT	1	
37		700IB667	DECAL - DANGER	1	
38		70000803	DECAL-VERMEER 8 1/2	1	
39		7000I530	DECAL-WARNING (NAVIGATORS)	1	
		901228154	Decal Assembly - D150x300 (International)		

Decal Assy-International Fig 1-2x01r01

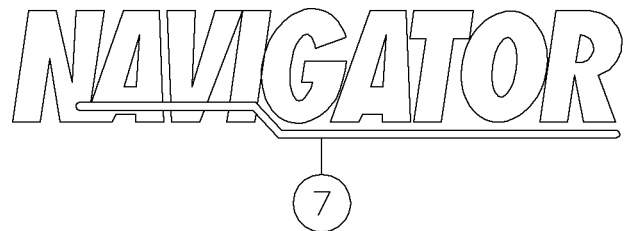
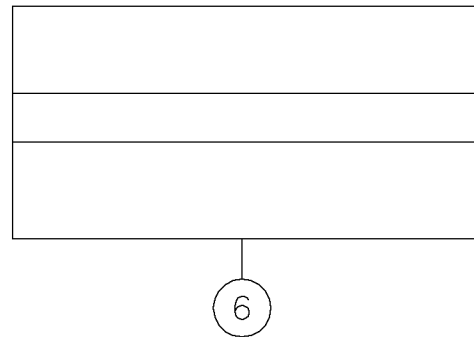
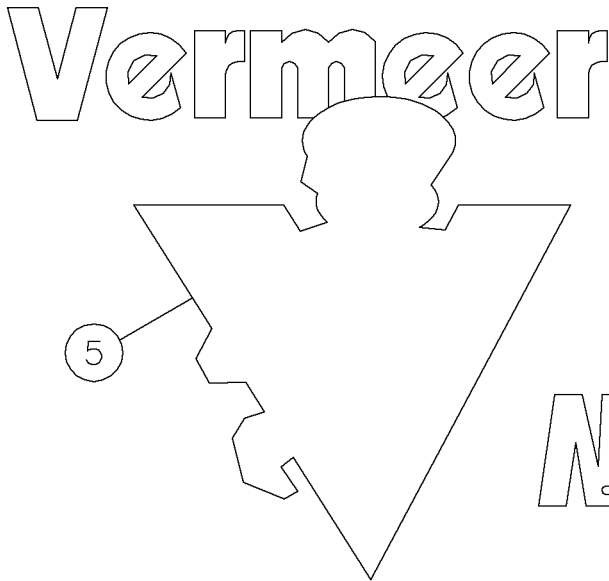
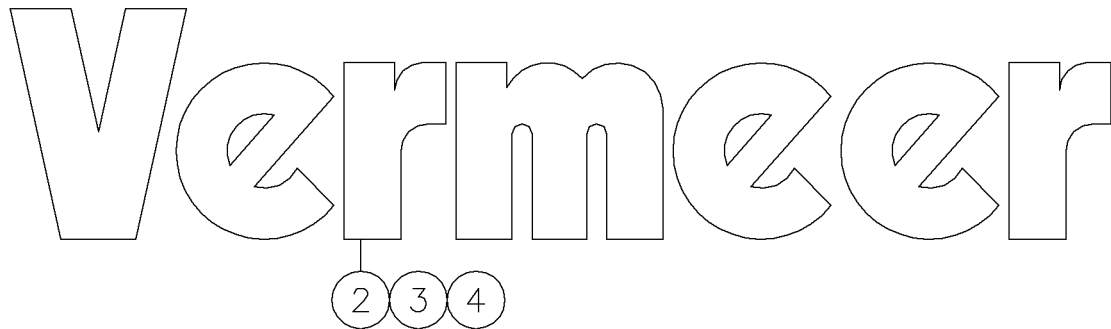
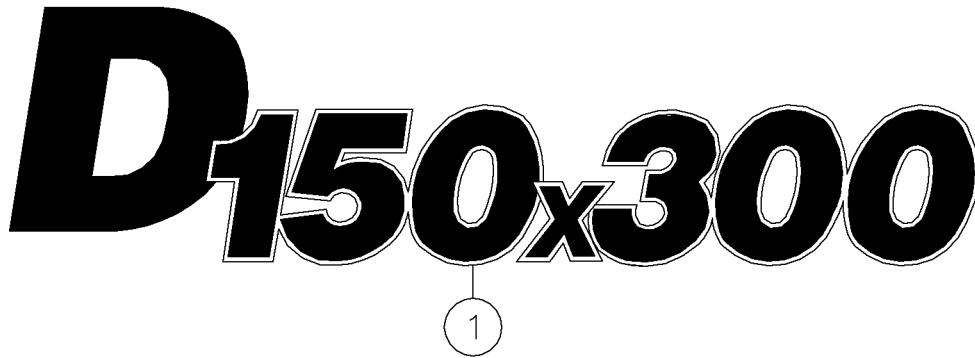

Decal Assy-International Fig 1-2x01r01

REF. NO.	*	PART NO.	DESCRIPTION	QTY.	REMARKS
		Revision Date	October, 2004		Update In Illustration & Parts List.
1		7000B411	DECAL - MODEL NUBMER - D150 X 300	1	
2		7000B276	DECAL - 6" VERMEER	1	
3		7000A557	VERMEER DECAL(WHITE)	2	
4		70000803	DECAL-VERMEER 8 1/2	1	
5		70000940	DECAL-20" VERMEER LOGO	2	
6		70000777	DECAL 6"VERMEER STRIPE	25 FT	
7		70000614	DECAL-MODEL NAVIGATOR (BIG)	2	
		901228154	DECAL ASSEMBLY-D150X300(INTERNATIONAL)		Inc 1-2x01Thru 1-5x01

Decal Assy-International Fig 1-2x01



Decal Assy-International Fig 1-2x01

REF. NO.	*	PART NO.	DESCRIPTION	QTY.	REMARKS
1		7000B411	DECAL - MODEL NUBMER - D150 X 300	1	
2		7000B276	DECAL - 6" VERMEER	1	
3		7000A557	VERMEER DECAL	2	
4		70000803	DECAL-VERMEER 8 1/2	1	
5		70000940	DECAL-20" VERMEER LOGO	2	
6		70000777	DECAL 6"VERMEER STRIPE	25 Ft	
7		70000614	DECAL-MODEL NAVIGATOR (BIG)	2	
8		901228154	DECAL ASSY - D150X300 DOMESTIC		Inc 1-2x01-1-2x05

Decal Assy-International Fig 1-2x02r01



1

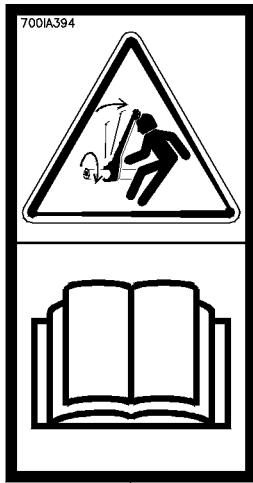

2



3

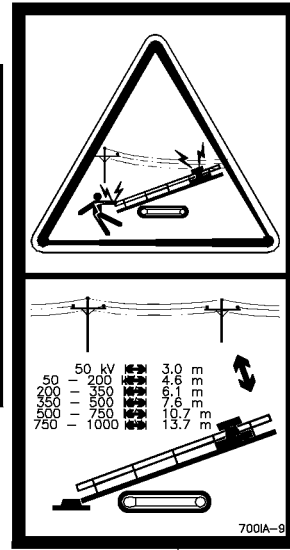

4

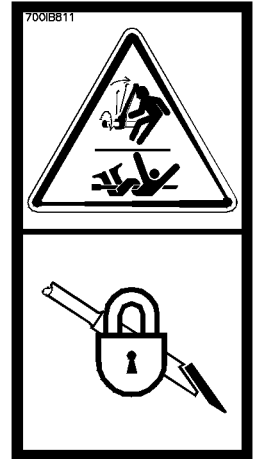

5



7

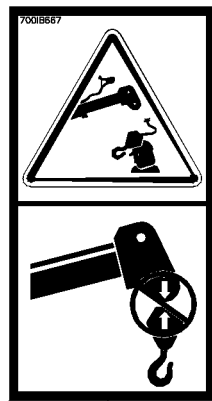

8

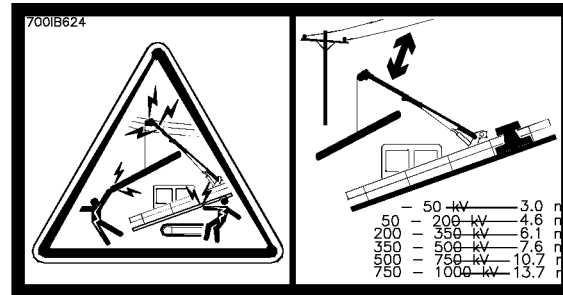

6



9

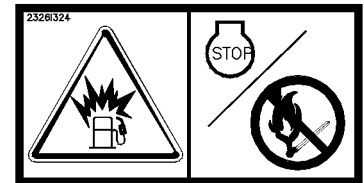

10

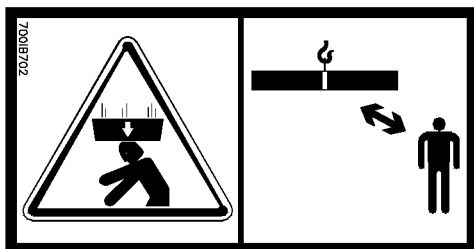

11

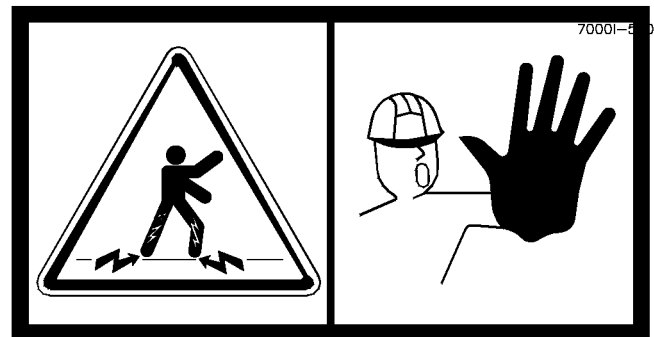

12

Decal Assy-International Fig 1-2x02r01

REF. NO.	*	PART NO.	DESCRIPTION	QTY.	REMARKS
		Revision Date	October, 2004		Update In Illustration & Parts List.
1		700IA393	DECAL - DANGER	4	
2		700IA394	DECAL - WARNING	2	
3		700I044	DECAL-WARNING	1	
4		700IA971	DECAL-DANGER	1	
5		700IB811	DECAL - DANGER - RLE INTERNATIONAL	3	
6		700IB624	DECAL - DANGER KEEP AWAY	1	
7		700IB711	DECAL - WARNING - FALLING LOAD	1	
8		700IB667	DECAL - DANGER	1	
9		2326I315	DECAL-WARNING	1	
10		2326I324	DECAL - WARNING EXPLOSION	1	
11		700IB702	DECAL - DANGER - FALLING LOAD	1	
12		7000I530	DECAL-WARNING (NAVIGATORS)	1	
		901228154	DECAL ASSEMBLY- D150X300(INTERNATIONAL)		Inc Fig 1-2x01 Thru 1-2x05

Decal Assy-International Fig 1-2x02

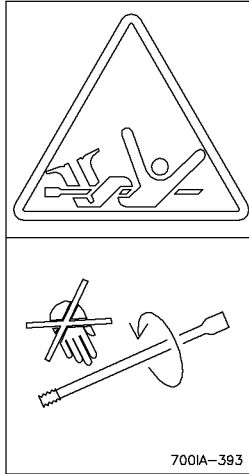

1

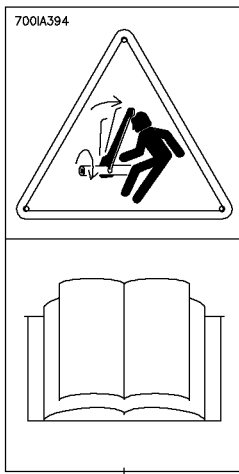

2

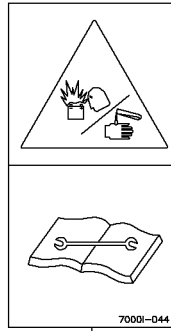

3

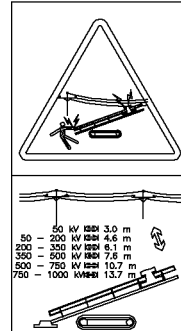

4

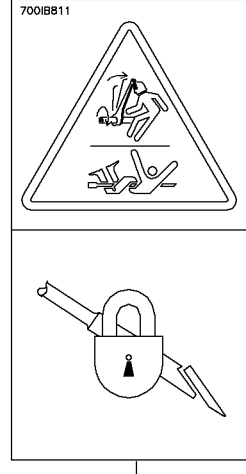

5

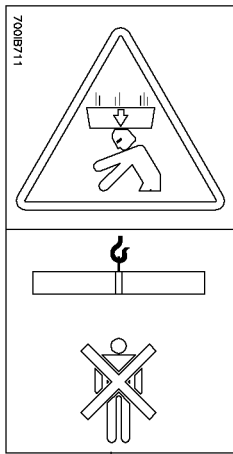

7

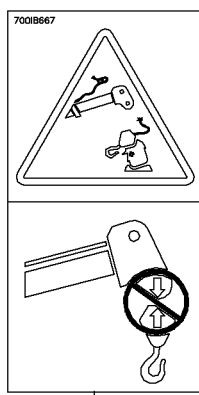

8

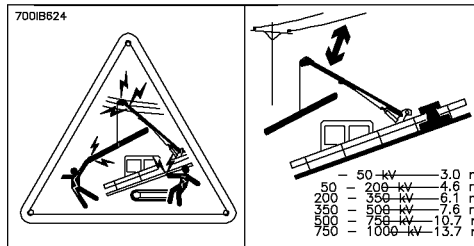

6

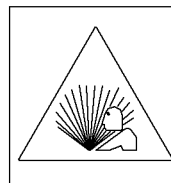

9

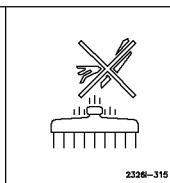

12

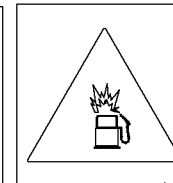

10

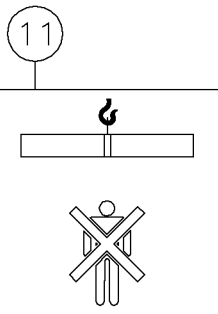
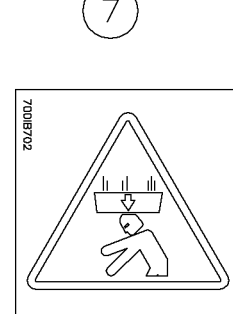
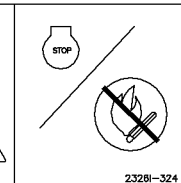

11

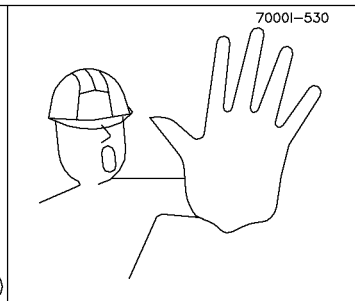
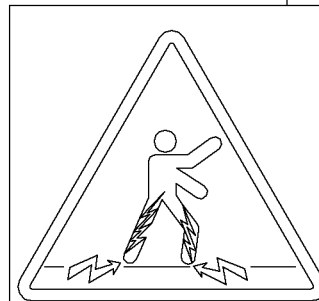

13

Decal Assy-International Fig 1-2x02

REF. NO.	*	PART NO.	DESCRIPTION	QTY.	REMARKS
1		700IA393	DECAL - DANGER	4	
2		700IA394	DECAL - WARNING	2	
3		700I044	DECAL-WARNING	1	
4		700IA971	DECAL-DANGER	1	
5		700IB811	DECAL - DANGER - RLE INTERNATIONAL	3	
6		700IB624	DECAL - DANGER KEEP AWAY	1	
7		700IB711	DECAL - WARNING - FALLING LOAD	1	
8		700IB667	DECAL - DANGER	1	
9		2326I315	DECAL-WARNING	1	
10		2326I324	DECAL-WARNING	1	
11		700IB702	DECAL - DANGER - FALLING LOAD	1	
12		7000I530	DECAL-WARNING (NAVIGATORS)	1	
13		901228154	DECAL ASSY-D150X300 INTERNATIONAL	1	Inc Fig 1-2x01 Thru Fig 1-2x05

Decal Assy-International Fig 1-2x03r01

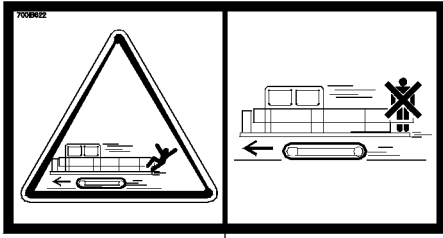

1

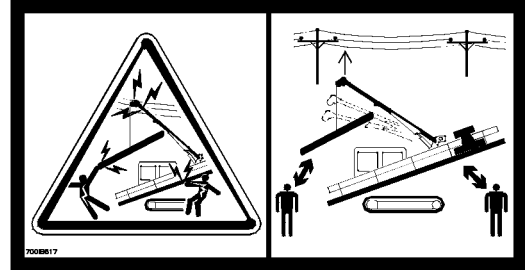

2

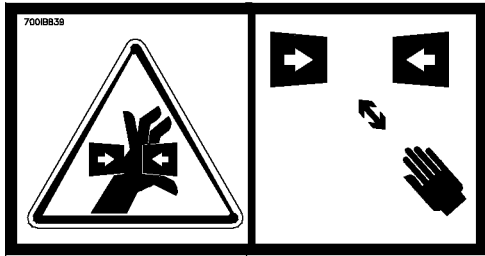

3

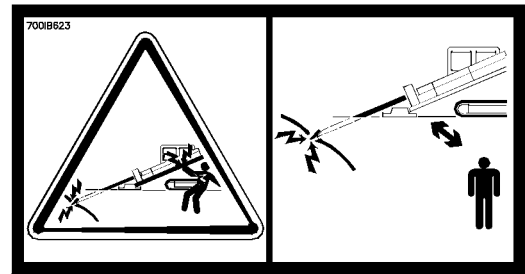

4

5

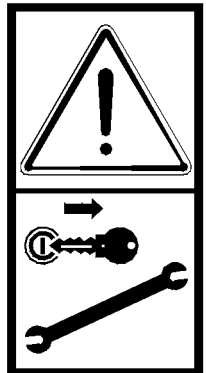
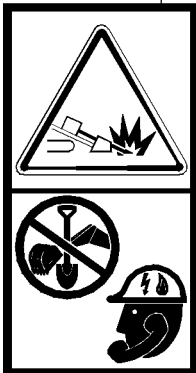
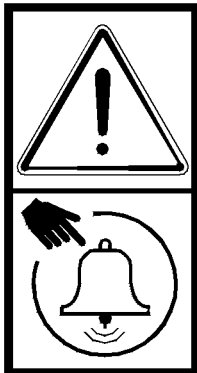
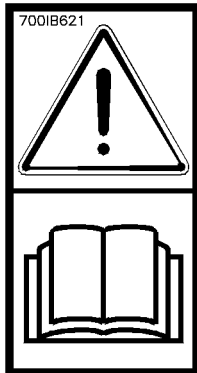

Decal Assy-International Fig 1-2x03r01

REF. NO.	*	PART NO.	DESCRIPTION	QTY.	REMARKS
		Revision Date	October, 2004		Update In Illustration & Parts List.
1		700IB622	DECAL - WARNING NO RIDERS	1	
2		700IB617	DECAL - DANGER POWER LINES	5	
3		700IB839	DECAL - WARNING	2	
4		700IB623	DECAL - DANGER ELECTRIC SHOCK	6	
5		700IB621	DECAL - WARNING LAUNDRY LIST	1	
				1	
		901228154	DECAL ASSEMBLY-D150X300(INTERNATIONAL)		Inc Fig 1-2x01 Thru 1-2x05

Decal Assy-International Fig 1-2x03

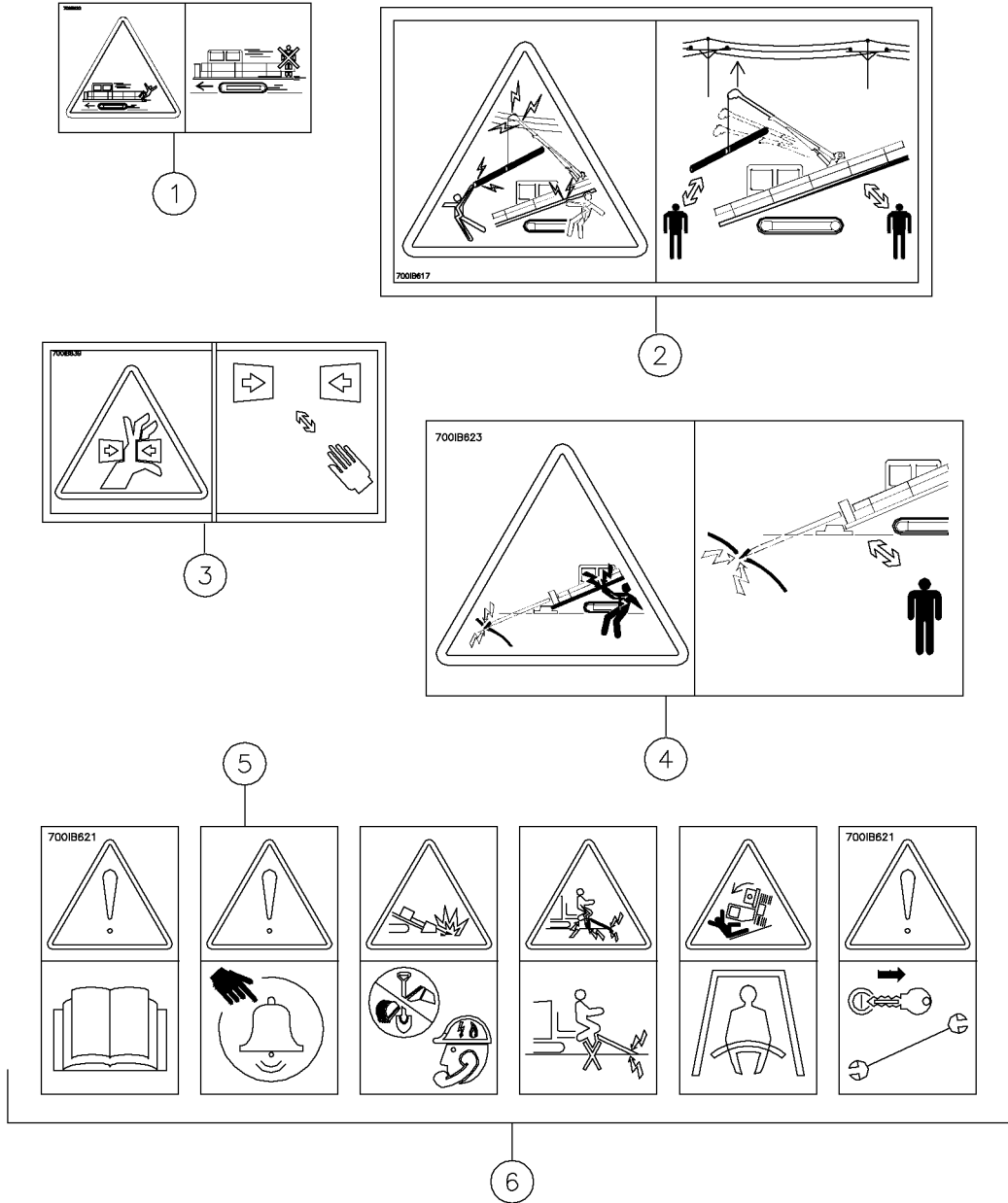

Decal Assy-International Fig 1-2x03

REF. NO.	*	PART NO.	DESCRIPTION	QTY.	REMARKS
1		700IB622	DECAL - WARNING NO RIDERS	1	
2		7000B617	DECAL - DANGER POWER LINES	5	
3		700IB839	DECAL - WARNING	2	
4		700IB623	DECAL - DANGER ELECTRIC SHOCK	6	
5		700IB621	DECAL - WARNING LAUNDRY LIST	1	
6		901228154	DECAL ASSY-D150X300 INTERNATIONAL	1	Inc Fig 1-2x01 Thru Fig 1-2x05

Decal Assy-International Fig 1-2x04r01

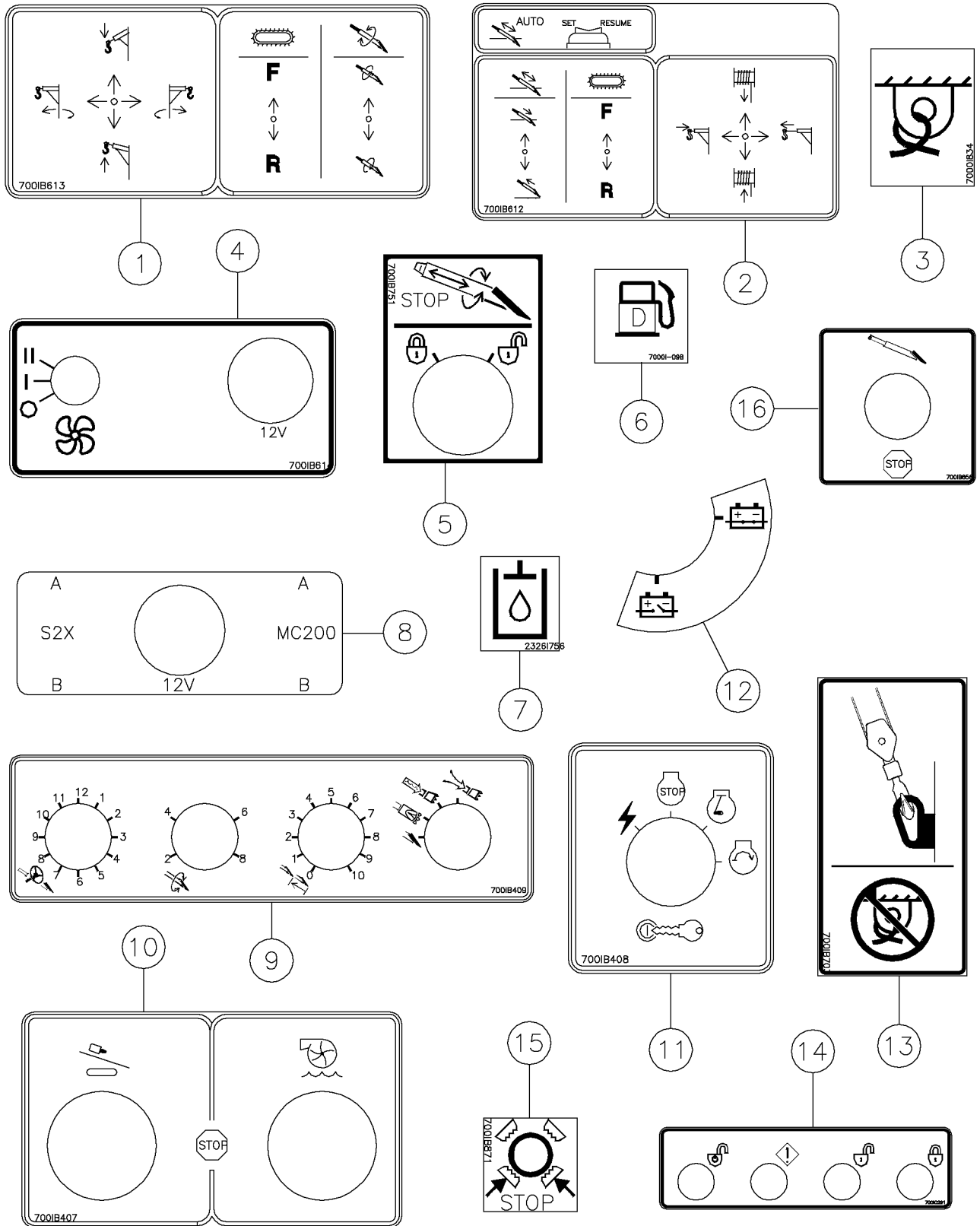

Decal Assy-International Fig 1-2x04r01

REF. NO.	*	PART NO.	DESCRIPTION	QTY.	REMARKS
		Revision Date	October, 2004		Update In Illustration & Parts List.
1		700IB613	DECAL - LEFT JOYSTICK	1	
2		700IB612	DECAL - RIGHT JOYSTICK	1	
3		7000I834	DECAL - TIE DOWN POINT	7	
4		700IB614	DECAL - OVERHEAD CONTROLS	1	
5		700IB751	DECAL - LOCKOUT	1	
6		7000I098	DECAL-DIESEL FUEL	1	
7		2326I756	DECAL-HYDRAULIC FLUID	1	
8		700IB410	DECAL - POWER POINT	1	
9		700IB409	DECAL - AUTO STEERING	1	
10		700IB407	DECAL - EMERGENCY STOP	1	
11		700IB408	DECAL - IGNITION	1	
12		700IA695	DECAL-BATTERY DISCONNECT	1	
13		700IB703	DECAL - HOOK	1	
14		700IC291	DECAL - REMOTE LOCKOUT	2	
15		700IB871	DECAL - VISE BUTTON	1	
16		700IB656	DECAL - E-STOP DRILLING OPERATION	1	
		901228154	DECAL ASSEMBLY- D150X300(INTERNATIONAL)		Inc Fig 1-2x01 Thru 1-2x05

Decal Assy-International Fig 1-2x04

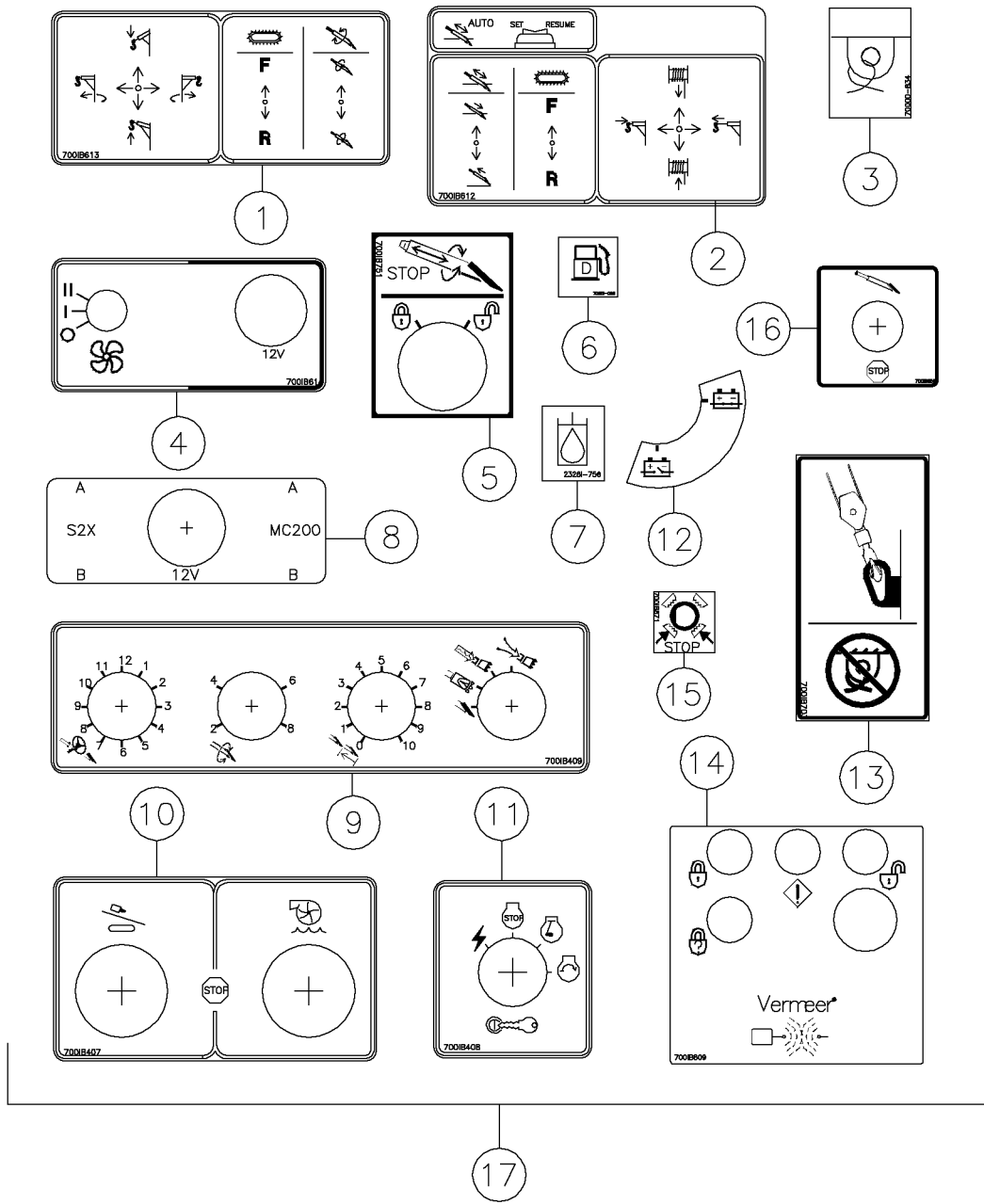

Decal Assy-International Fig 1-2x04

REF. NO.	*	PART NO.	DESCRIPTION	QTY.	REMARKS
1		700IB613	DECAL - LEFT JOYSTICK	1	
2		700IB612	DECAL - RIGHT JOYSTICK	1	
3		7000I834	DECAL - TIE DOWN POINT	7	
4		700IB614	DECAL - OVERHEAD CONTROLS	1	
5		700IB751	DECAL - LOCKOUT	1	
6		7000I098	DECAL-DIESEL FUEL	1	
7		2326I756	DECAL-HYDRAULIC FLUID	1	
8		700IB410	DECAL - POWER POINT	1	
9		700IB409	DECAL - AUTO STEERING	1	
10		700IB407	DECAL - EMERGENCY STOP	1	
11		700IB408	DECAL - IGNITION	1	
12		700IA695	DECAL-BATTERY DISCONNECT	1	
13		700IB703	DECAL - HOOK	1	
14		700IB809	DECAL - REMOTE LOCKOUT	1	
15		700IB871	DECAL - VISE BUTTON	2	
16		700IB656	DECAL - E-STOP DRILLING OPERATION	1	
17		901228154	DECAL ASSEMBLY- D150X300(INTERNATIONAL)	1	Inc Fig 1-2x01 Thru Fig 1-2x05

Decal Assy-International Fig 1-2x05r01

⚠ DANGER

AN UNTRAINED OPERATOR SUBJECTS HIMSELF AND OTHERS TO DEATH OR SERIOUS INJURY DO NOT OPERATE CRANE UNLESS

- You have been trained in the safe operation of this crane.
- You have read, understand and follow the safety and operating recommendations in the Operator's Manual, your employer's work rules, applicable government regulations, and industry standards.
- You have read, understand and follow all safety signs and are sure that all guards, safety signs and other safety features are in place and in proper condition.

FAILURE TO OBEY THE FOLLOWING WILL RESULT IN DEATH OR SERIOUS INJURY

- Inspect crane and its operation daily.
- For crane stability use only on solid, level surface.
- Crane must be level.
- Operate all controls slowly and smoothly.
- Keep load under boom tip. Do not slide load boom or drag loads. Avoid free-swinging loads.
- Keep at least 3 wraps of load line on which drum.
- For travel, boom must be in stowed position.
- The operator must reduce loads to allow for factors such as wind, ground conditions, operating speeds and the effect of freely suspended loads.
- Read, understand, and follow the crane load and work area charts.
- Do not exceed winch or crane ratings.
- Follow all recommended inspections and maintenance practices listed in the manufacturer's manuals. If manuals are missing contact manufacturer for replacement.
- Do not modify or alter this crane without written manufacturer's approval. Use only manufacturer approved attachments or parts on this crane.
- If crane is remounted or rebuilt, the crane must be recertified.

7000B712

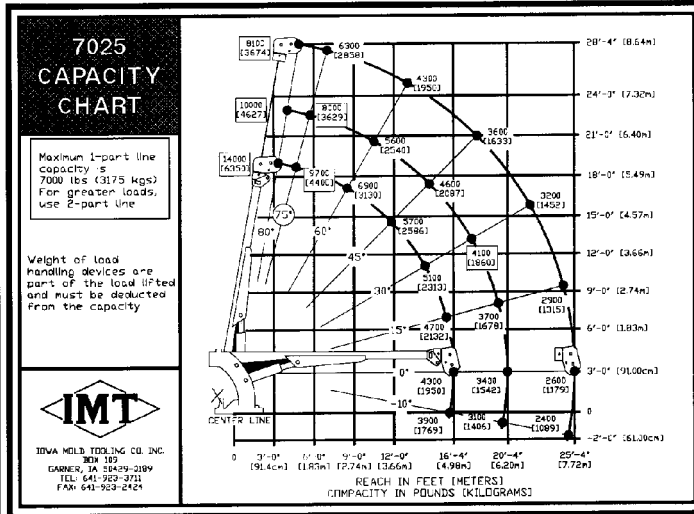

This product may be covered by one or more of the following patents:

AU 735,936	US 6,660,041	US 6,195,822	US 6,477,795
CA D 76,593	US 6,607,280	US 6,247,544	US 6,484,818
DE 696 11 848	US 5,811,496	US 6,289,997	US 6,491,115
DE 202 14 989.8	US 5,867,803	US 6,306,787	US 6,497,296
DE Des. 98 006 85.4	US 5,859,985	US 6,315,922	US 6,511,280
EP 772,543	US 5,887,807	US 6,332,502	US 6,515,899
EP 830,522	US 5,892,548	US 6,357,537	US 6,517,733
EP 885,343	US 5,892,549	US 6,360,830	US 6,533,048
EP 1,153,194	US 5,704,142	US 6,367,594	US 6,533,052
GB 2,053,838	US 5,720,354	US 6,374,928	US 6,554,082
HK 1015859	US 5,746,278	US 6,382,330	US 6,557,651
RU 2,158,952	US 6,768,811	US 6,389,380	US 6,577,954
US Des. 366,882	US 5,778,991	US 6,390,207	US 6,588,062
US Des. 366,837	US 5,819,859	US 6,406,952	US 6,589,516
US 4,844,423	US 5,845,589	US 6,406,954	US 6,591,755
US 5,205,181	US 5,804,210	US 6,412,715	US 6,599,202
US 5,219,380	US 5,844,121	US 6,422,495	US 6,599,946
US 5,237,898	US 5,950,942	US 6,435,298	US 6,594,538
US 5,291,964	US 6,014,998	US 6,439,319	US 6,701,647
US 5,538,220	US 6,050,350	US 6,445,385	US 6,719,099
US 5,544,055	US 6,109,367	US 6,446,889	US 6,725,579
US 5,565,407	US 6,119,376	US 6,454,025	US 6,729,050
US 5,558,253	US 6,138,932	US 6,470,878	
US 5,574,642	US 6,154,987	US 6,474,931	
US 5,588,474	US 6,161,830	US 6,474,932	

This product may be covered by one or more of the following licensed patents:

US 4,684,913	US 4,867,255	US 5,148,890
US 4,868,704	US 4,953,638	US 5,796,740

(OTHER U.S. AND FOREIGN PATENTS PENDING)

Notice • Avis • Hinweis • Avviso • Aviso

If you purchased this product as used equipment, you can receive a FREE Operator's Manual by contacting:

Si vous avez acheté cet équipement d'occasion, vous pouvez recevoir un manuel de l'opérateur GRATUIT en composant le:

Wenn Sie diese Maschine gebraucht erworben haben, können Sie eine KOSTENLOSE Betriebsanleitung wie folgt anfordern:

Se si è comprata la presente macchina usata, si può ricevere una copia del manuale dell'operatore IN OMAGGIO, contattando:

Si este producto que ha comprado es un equipo usado, puede recibir un manual del operador GRATUITO llamando al:

Vermeer Manufacturing Company
ATTN: Customer Data Department
1210 Vermeer Road East, PO BOX 200
Pella, IA 50219 USA
800-828-0061 or 641-628-3141
Telephone: English speaking only
Téléphone: en anglais uniquement
Telefon: Nur in Englischer Sprache
Telefono: tutte le comunicazioni saranno in Inglese
Telefono: en Inglés solamente

OR by completing and mailing the Used Equipment Registration Form enclosed in the Operator's Manual. OU en remplissant et en envoyant le formulaire d'enregistrement de l'équipement d'occasion inclus dans le manuel de l'opérateur.
ODER das in der Betriebsanleitung enthaltene Formular zur Registrierung gebrauchter Ausrüstung ausfüllen und einsenden.
OPPURE compilando e spedendo il modulo di registrazione per macchinari usati, incluso al manuale dell'operatore.
O rellenando y enviando por correo el impreso de registro de equipos usados incluido en el manual del operador.

Decal Assy-International Fig 1-2x05r01

REF. NO.	*	PART NO.	DESCRIPTION	QTY.	REMARKS
		Revision Date	October, 2004		Update In Illustration & Parts List.
1		7000B712	DECAL - DANGER	1	
2		296264801	DECAL - CAPACITY CHART 7.5 X 5.5	1	
3		296264802	DECAL - CAPACITY CHART 8.25 X 12	1	
4		2326940	DECAL-NOTICE TO OWNERS	1	
5		7000B119	DECAL - PATENT INDUSTRIAL	1	
		901228156	DECAL ASSY-D300X500 NAV.-INTERNATIONAL		Inc Fig 1-2x01 Thru 1-2x05

Decal Assy-International Fig 1-2x05

⚠ DANGER

AN UNTRAINED OPERATOR SUBJECTS HIMSELF AND OTHERS TO DEATH OR SERIOUS INJURY DO NOT OPERATE CRANE UNLESS

- You have been trained in the safe operation of this crane.
- You have read, understand and follow the safety and operating recommendations in the Operator's Manuals, your employer's work rules, applicable government regulations and industry standards.
- You read, understand and follow all safety signs and are sure that all guards, safety signs and other safety features are in place and in proper condition.

FAILURE TO OBEY THE FOLLOWING WILL RESULT IN DEATH OR SERIOUS INJURY

- Inspect crane and its operation daily.
- For crane stability use only on solid, level surface.
- Crane must be level.
- Operate all controls slowly and smoothly.
- Keep load under boom tip. Do not side load boom or drag loads. Avoid free swinging loads.
- Keep at least 3 wraps of load line on winch drum.
- For travel, boom must be in stowed position.
- The operator must reduce loads to allow for factors such as wind, ground conditions, operating speeds and the effect of freely suspended loads.
- Read, understand and follow the crane load and work area charts.
- Do not exceed winch or crane ratings.
- Follow all recommended inspections and maintenance practices listed in the manufacturer's manuals. If manuals are missing contact manufacturer for replacement.
- Do not modify or alter this crane without written manufacturer's approval. Use only manufacturer approved attachments or parts on this crane.
- If crane is repainted or rebuilt, the crane must be recertified.

7000B712

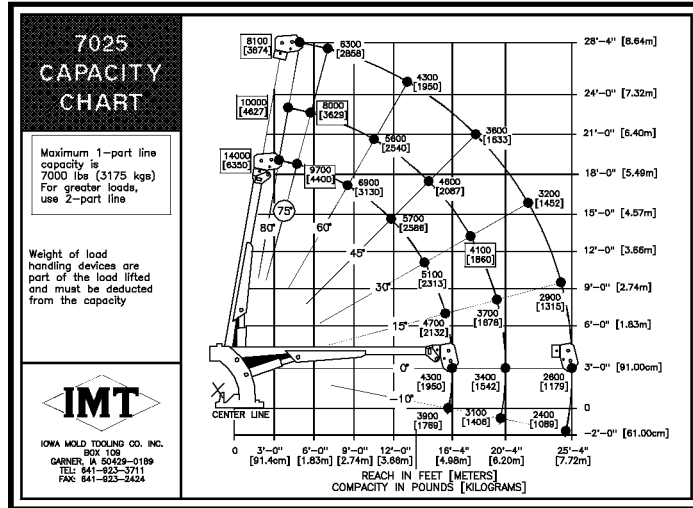

NOTICE TO OWNER

You are requested to notify Vermeer Mfg. Co when you have purchased this machine.

Methods of Notification:

- New machine owner: Ask your dealer to fill out and return your Limited Warranty Card.
- Pre-owned machine owner: Send in Customer Data Card (located in operator's manual) or write Vermeer Mfg. Co. at Box 200, Pella, Iowa 50219 ATTN: Customer Data Dept. or call 1-800-829-0051 or (515) 628-3141.

An owner of a pre-owned machine will receive a free operator's manual if requested (1 per owner). A new machine owner will receive an operator's manual with the machine.

2326-940

This product may be covered by one or more of the following patents:

CA D 79,593	US 5,219,380	US 5,704,142	US 6,247,544
CC 95 914 404.5	US 5,237,888	US 5,720,354	US 6,289,997
CC ZL96195734.4	US 5,291,964	US 5,746,278	US 6,290,155
DE 696 11 846	US 5,394,583	US 5,768,811	US 6,308,787
DE Des. 96 006 85.4	US 5,507,441	US 5,778,991	US 6,315,062
EP 772,543	US 5,509,220	US 5,819,859	US 6,332,502
EP 885,343	US 5,544,055	US 5,845,689	US 6,357,537
GB 2,053,636	US 5,553,407	US 5,904,210	US 6,360,830
HK 1015859	US 5,556,253	US 5,941,320	US 6,367,564
RU 2,141,907	US 5,574,642	US 5,944,121	US 6,374,928
RU 2,158,952	US 5,588,474	US 5,950,942	US 6,382,330
RU 2,163,963	US 5,590,041	US 6,014,996	US 6,389,360
RU 2,175,368	US 5,607,280	US 6,050,350	
US Des. 308,682	US 5,611,496	US 6,109,367	
US Des. 396,837	US 5,657,803	US 6,119,376	
US 4,848,423	US 5,659,985	US 6,138,932	
US 5,074,063	US 5,687,807	US 6,154,987	
US 5,088,532	US 5,692,548	US 6,161,630	
US 5,205,181	US 5,692,549	US 6,195,922	

This product may be covered by one or more of the following licensed patents:

US 4,694,913	US 4,867,255	US 5,148,880
US 4,858,704	US 4,953,638	US 5,799,740

(OTHER U.S. AND FOREIGN PATENTS PENDING)

Decal Assy-International Fig 1-2x05

REF. NO.	*	PART NO.	DESCRIPTION	QTY.	REMARKS
1		7000B712	DECAL - DANGER	1	
2		296264801	DECAL - CAPACITY CHART 7.5 X 5.5	1	
3		296264802	DECAL - CAPACITY CHART 8.25 X 12	1	
4		2326940	DECAL-NOTICE TO OWNERS	1	
5		7000B119	DECAL - PATENT	1	
6		901228156	DECAL ASSY-D150x300 INTERNATIONAL	1	Inc Fig 1-2x01 Thru Fig 1-2x05

Decal Location Assy-1 Fig 1-3r01

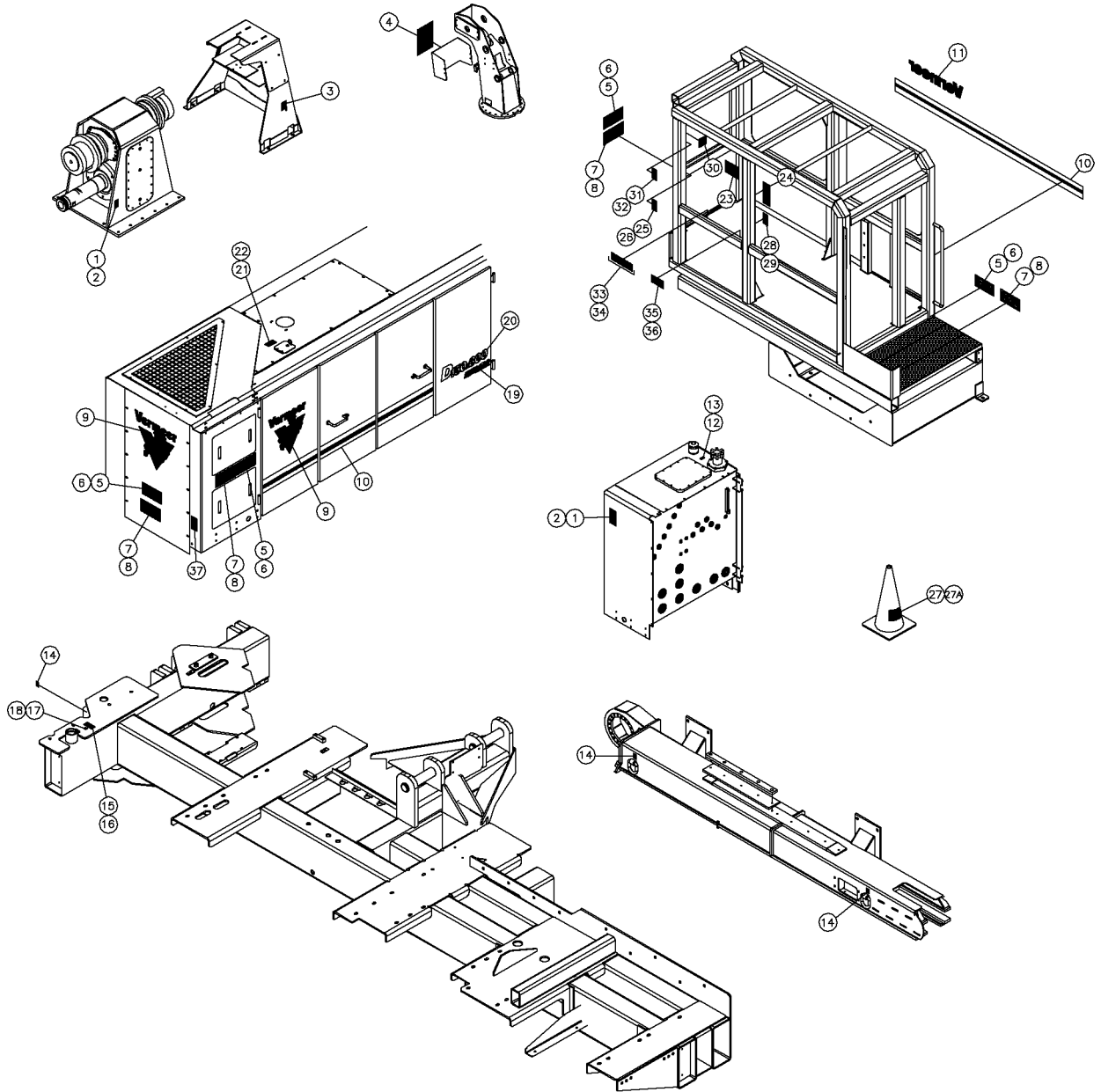

Decal Location Assy-1 Fig 1-3r01

REF. NO.	*	PART NO.	DESCRIPTION	QTY.	REMARKS
		Revision Date	June, 2002		Add And Delete Parts
1		7000A393	DECAL - DANGER	2	
2		700IA393	DECAL - DANGER	2	International
3	*	700IB751	DECAL-LOCKOUT	2	International
4		296264802	DECAL - CAPACITY CHART 8.25 X 12	1	
5		7000B623	DECAL - DANGER ELECTRIC SHOCK	4	
6		700IB623	DECAL - DANGER ELECTRIC SHOCK	4	International
7		7000B617	DECAL - DANGER POWER LINES	4	
8		700IB617	DECAL - DANGER POWER LINES	4	International
9		70000940	DECAL-20" VERMEER LOGO	2	
10		70000777	DECAL 6"VERMEER STRIPE	A/R	P/N Qty Of 1 = 1 Foot
11		70000803	DECAL-VERMEER 8 1/2	1	
12		2326756	DECAL-HYDRAULIC OIL	1	
13		2326I756	DECAL-HYDRAULIC FLUID	1	International
14		7000I834	DECAL - TIE DOWN POINT	6	
15		2326324	DECAL-WARNING/REFUEL	1	
16		2326I324	DECAL-WARNING	1	International
17		70000098	DECAL-DIESEL (AT/UND)	1	
18		7000I098	DECAL-DIESEL FUEL	1	International
19		70000614	DECAL-MODEL NAVIGATOR (BIG)	1	
20		7000B411	DECAL - MODEL NUBMER - D150 X 300	1	
21		2326315	DECAL-WARNING	1	
22		2326I315	DECAL-WARNING	1	International
23		296264801	DECAL - CAPACITY CHART 7.5 X 5.5	1	
24		7000B712	DECAL - DANGER	1	
25		7000B711	DECAL - WARNING - FALLING LOAD	1	
26		700IB711	DECAL - WARNING - FALLING LOAD	1	International
27		70000530	DECAL-DANGER	1	
27A		7000I530	DECAL-WARNING (NAVIGATORS)	1	International
28		7000B667	DECAL - DANGER	1	
29		700IB667	DECAL - DANGER	1	International
30		7000B119	DECAL - PATENT INDUSTRIAL	1	
31		7000A971	DECAL - DANGER	1	
32		700IA971	DECAL-DANGER	1	International
33		7000B621	DECAL - WARNING LAUNDRY LIST	1	
34		700IB621	DECAL - WARNING LAUNDRY LIST	1	International
35		7000B624	DECAL - DANGER KEEP AWAY	1	
36		700IB624	DECAL - DANGER KEEP AWAY	1	International
37	*	700IB703	DECAL - HOOK	1	International

Decal Location Assy-1 Fig 1-3

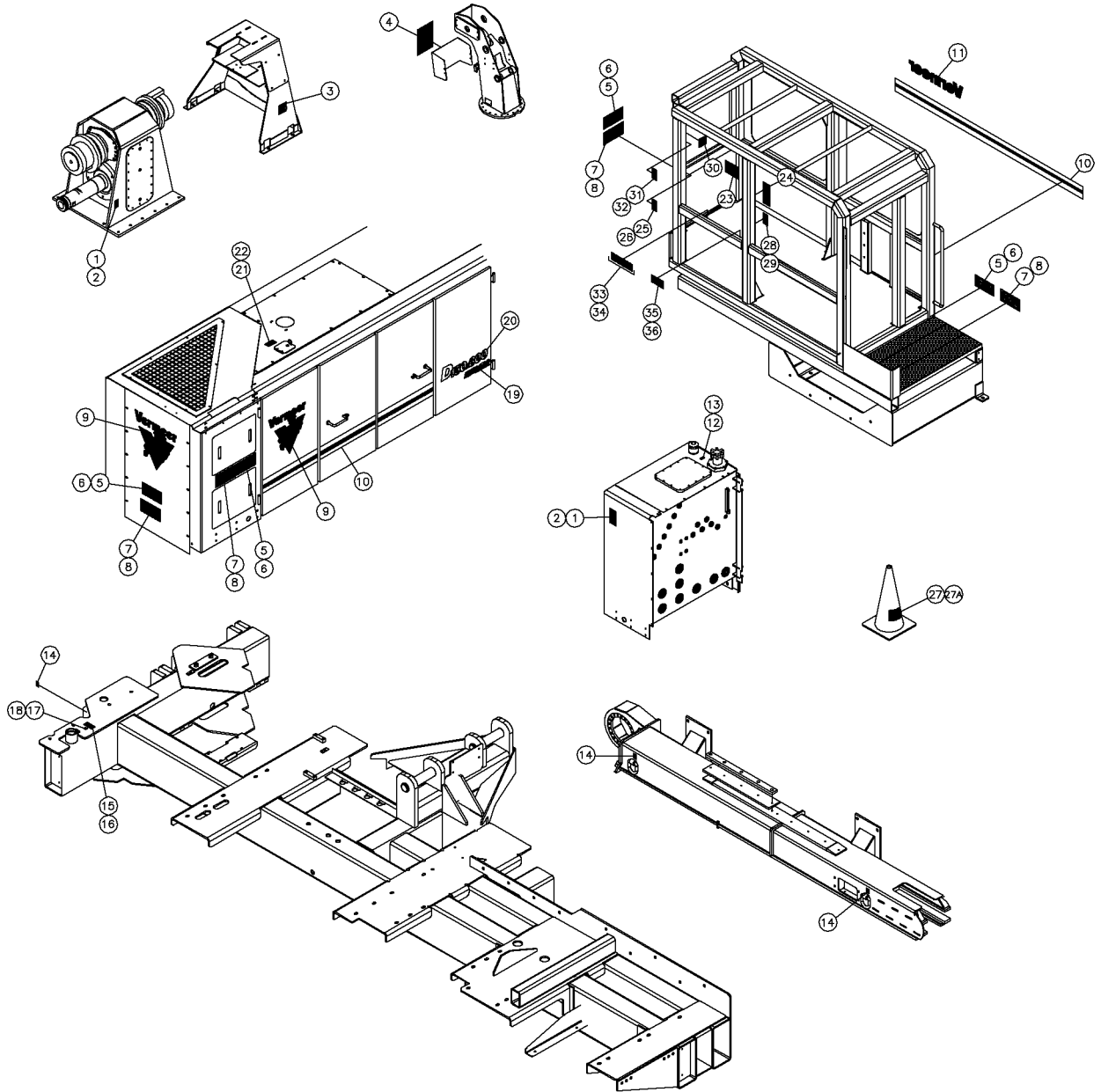

Decal Location Assy-1 Fig 1-3

REF. NO.	*	PART NO.	DESCRIPTION	QTY.	REMARKS
1		7000A393	DECAL - DANGER	2	
2		700IA393	DECAL - DANGER	2	International
3		700IB656	DECAL - E-STOP DRILLING OPERATION	1	
4		296264802	DECAL - CAPACITY CHART 8.25 X 12	1	
5		7000B623	DECAL - DANGER ELECTRIC SHOCK	4	
6		700IB623	DECAL - DANGER ELECTRIC SHOCK	4	International
7		7000B617	DECAL - DANGER POWER LINES	4	
8		700IB617	DECAL - DANGER POWER LINES	4	International
9		70000940	DECAL-20" VERMEER LOGO	2	
10		70000777	DECAL 6"VERMEER STRIPE	A/R	P/N Qty Of 1 = 1 Foot
11		70000803	DECAL-VERMEER 8 1/2	1	
12		2326756	DECAL-HYDRAULIC OIL	1	
13		2326I756	DECAL-HYDRAULIC FLUID	1	International
14		7000I834	DECAL - TIE DOWN POINT	6	
15		2326324	DECAL-WARNING/REFUEL	1	
16		2326I324	DECAL-WARNING	1	International
17		70000098	DECAL-DIESEL (AT/UND)	1	
18		7000I098	DECAL-DIESEL FUEL	1	International
19		70000614	DECAL-MODEL NAVIGATOR (BIG)	1	
20		7000B411	DECAL - MODEL NUBMER - D150 X 300	1	
21		2326315	DECAL-WARNING	1	
22		2326I315	DECAL-WARNING	1	International
23		296264801	DECAL - CAPACITY CHART 7.5 X 5.5	1	
24		7000B712	DECAL - DANGER	1	
25		7000B711	DECAL - WARNING - FALLING LOAD	1	
26		700IB711	DECAL - WARNING - FALLING LOAD	1	International
27		70000530	DECAL-DANGER	1	
27A		7000I530	DECAL-WARNING (NAVIGATORS)	1	International
28		7000B667	DECAL - DANGER	1	
29		700IB667	DECAL - DANGER	1	International
30		7000B119	DECAL - PATENT INDUSTRIAL	1	
31		7000A971	DECAL - DANGER	1	
32		700IA971	DECAL-DANGER	1	International
33		7000B621	DECAL - WARNING LAUNDRY LIST	1	
34		700IB621	DECAL - WARNING LAUNDRY LIST	1	International
35		7000B624	DECAL - DANGER KEEP AWAY	1	
36		700IB624	DECAL - DANGER KEEP AWAY	1	International

Decal Location Assy-2 Fig 1-4r02

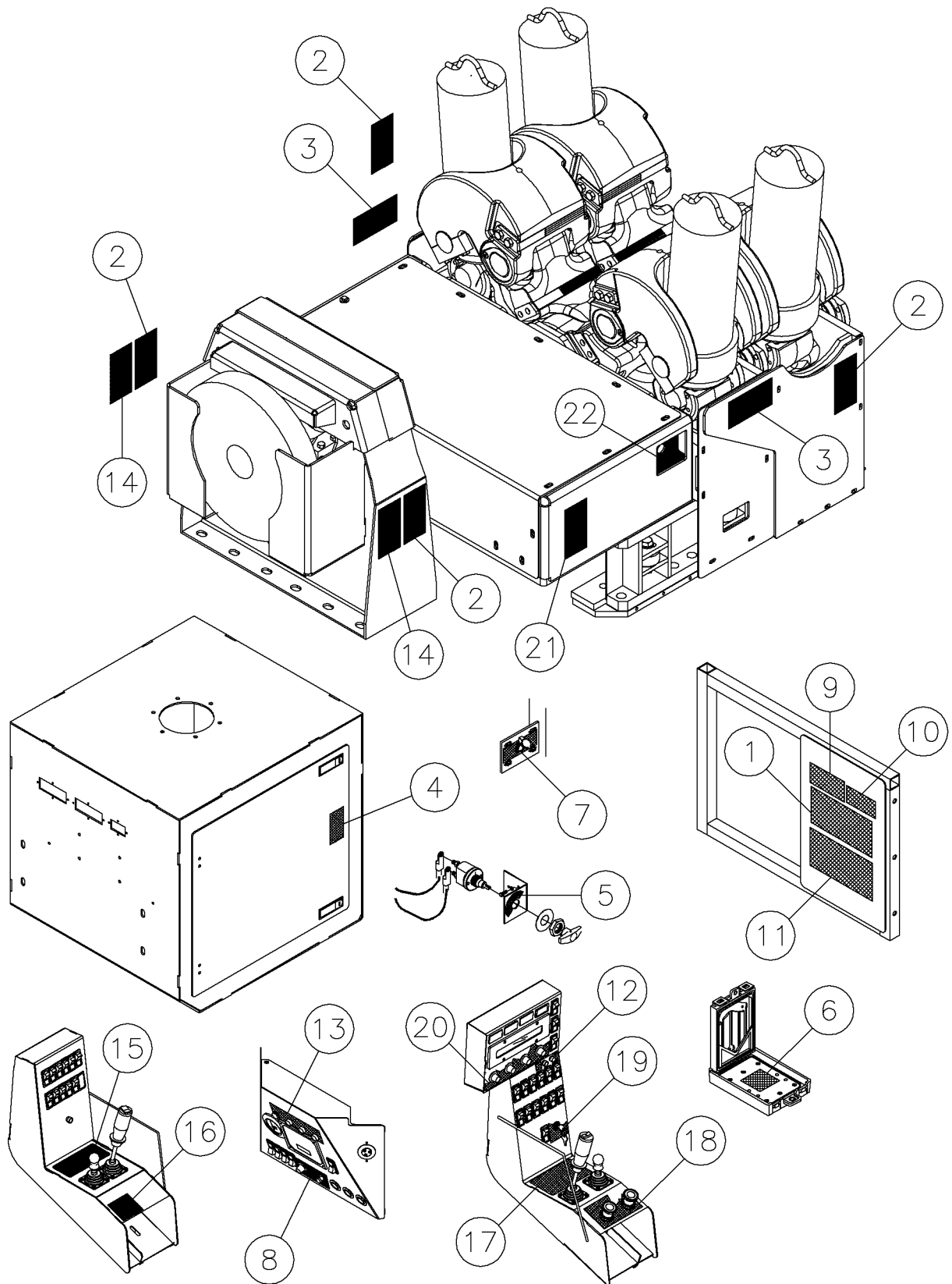

Decal Location Assy-2 Fig 1-4r02

REF. NO.	*	PART NO.	DESCRIPTION	QTY.	REMARKS
		Revision Date	October, 2004		Update In Illustration & Parts List.
1		7000B623	DECAL - DANGER ELECTRIC SHOCK	1	Domestic
		700IB623	DECAL - DANGER ELECTRIC SHOCK	1	International
2		7000A393	DECAL - DANGER	4	Domestic
		700IA393	DECAL - DANGER	4	International
3		7000B839	DECAL - WARNING	2	Domestic
		700IB839	DECAL - WARNING	2	International
4		70000044	DECAL-WARNING(AT/UND)	1	Domestic
		7000I044	DECAL-WARNING	1	International
5		700IA695	DECAL-BATTERY DISCONNECT	1	
6		2326940	DECAL-NOTICE TO OWNERS	1	
7		700IB410	DECAL - POWER POINT	1	
8		700IB614	DECAL - OVERHEAD CONTROLS	1	
9		7000B702	DECAL - DANGER - FALLING LOAD	1	Domestic
		700IB702	DECAL - DANGER - FALLING LOAD	1	International
10		7000B622	DECAL - WARNING NO RIDERS	1	Domestic
		700IB622	DECAL - WARNING NO RIDERS	1	International
11		7000B617	DECAL - DANGER POWER LINES	1	Domestic
		700IB617	DECAL - DANGER POWER LINES	1	International
12		700IB871	DECAL - VISE BUTTON	1	
13		700IC291	DECAL - REMOTE LOCKOUT	1	
14		7000A394	DECAL - WARNING	2	Domestic
		700IA394	DECAL - WARNING	2	International
15		700IB613	DECAL - LEFT JOYSTICK	1	
16		2326940	DECAL-NOTICE TO OWNERS	1	
17		700IB612	DECAL - RIGHT JOYSTICK	1	
18		700IB407	DECAL - EMERGENCY STOP	1	
19		700IB408	DECAL - IGNITION	1	
20		700IB409	DECAL - AUTO STEERING	1	
21		2326315	DECAL-WARNING	1	Domestic
		2326I315	DECAL-WARNING	1	International
22		700IB751	DECAL - LOCKOUT	1	

Decal Location Assy-2 Fig 1-4r01

REF. NO.	*	PART NO.	DESCRIPTION	QTY.	REMARKS
		Revision Date	June, 2002		Change Due To Update
1		7000B623	DECAL - DANGER ELECTRIC SHOCK	1	
1A		700IB623	DECAL - DANGER ELECTRIC SHOCK	3	International
2		7000A393	DECAL - DANGER	2	
2A		700IA393	DECAL - DANGER	2	International
3		7000B839	DECAL - WARNING	2	
3A		700IB839	DECAL - WARNING	2	International
4		70000044	DECAL-WARNING(AT/UND)	1	
4A		7000I044	DECAL-WARNING	1	International
5		700IA695	DECAL-BATTERY DISCONNECT	1	
6		2326940	DECAL-NOTICE TO OWNERS	1	
7		700IB410	DECAL - POWER POINT	1	
8		700IB614	DECAL - OVERHEAD CONTROLS	1	
9		7000B702	DECAL - DANGER - FALLING LOAD	1	
10		700IB702	DECAL - DANGER - FALLING LOAD	1	International
11		7000B622	DECAL - WARNING NO RIDERS	1	
12		700IB622	DECAL - WARNING NO RIDERS	1	International
13		7000B617	DECAL - DANGER POWER LINES	1	
14		700IB617	DECAL - DANGER POWER LINES	1	International
15		700IB613	DECAL - LEFT JOYSTICK	1	
16		2326940	DECAL-NOTICE TO OWNERS	1	
17		700IB612	DECAL - RIGHT JOYSTICK	1	
18		700IB407	DECAL - EMERGENCY STOP	1	
19		700IB408	DECAL - IGNITION	1	
20		700IB409	DECAL - AUTO STEERING	1	
21		2326315	DECAL-WARNING	1	
22		2326I315	DECAL-WARNING	1	International
23		700IB751	DECAL - LOCKOUT	1	
24		7000B811	DECAL - DANGER - RLE - DOMESTIC	1	
24A		700IB811	DECAL - DANGER - RLE INTERNATIONAL	1	International
25		7000A394	DECAL - WARNING	2	
25A		700IA394	DECAL - WARNING	2	International
26		700IB809	DECAL - REMOTE LOCKOUT	1	
27		700IB809	DECAL-VISE BUTTON	2	International

Decal Location Assy-2 Fig 1-4

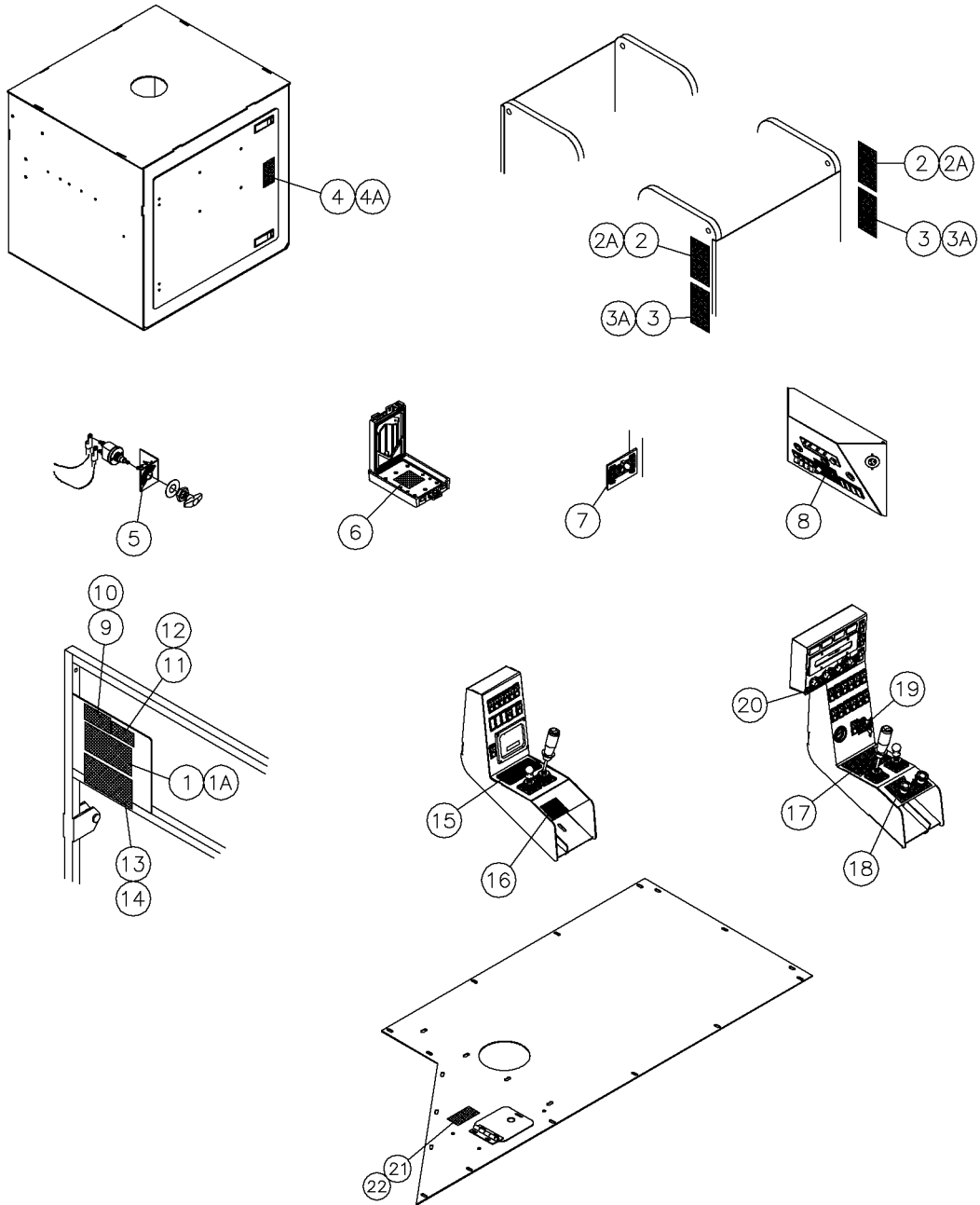

Decal Location Assy-2 Fig 1-4

REF. NO.	*	PART NO.	DESCRIPTION	QTY.	REMARKS
1		7000B623	DECAL - DANGER ELECTRIC SHOCK	1	
1A		700IB623	DECAL - DANGER ELECTRIC SHOCK	3	International
2		7000A393	DECAL - DANGER	2	
2A		700IA393	DECAL - DANGER	2	International
3		7000A394	DECAL - WARNING	2	
3A		700IA394	DECAL - WARNING	2	
4		70000044	DECAL-WARNING(AT/UND)	1	
4A		7000I044	DECAL-WARNING	1	International
5		700IA695	DECAL-BATTERY DISCONNECT	1	
6		2326940	DECAL-NOTICE TO OWNERS	1	
7		700IB410	DECAL - POWER POINT	1	
8		700IB614	DECAL - OVERHEAD CONTROLS	1	
9		7000B702	DECAL - DANGER - FALLING LOAD	1	
10		700IB702	DECAL - DANGER - FALLING LOAD	1	International
11		7000B622	DECAL - WARNING NO RIDERS	1	
12		700IB622	DECAL - WARNING NO RIDERS	1	International
13		7000B617	DECAL - DANGER POWER LINES	1	
14		700IB617	DECAL - DANGER POWER LINES	1	International
15		700IB613	DECAL - LEFT JOYSTICK	1	
16		2326940	DECAL-NOTICE TO OWNERS	1	
17		700IB612	DECAL - RIGHT JOYSTICK	1	
18		700IB407	DECAL - EMERGENCY STOP	1	
19		700IB408	DECAL - IGNITION	1	
20		700IB409	DECAL - AUTO STEERING	1	
21		2326315	DECAL-WARNING	1	
22		2326I315	DECAL-WARNING	1	International

Decal/Literature Box Assy Fig 1-5R01

REF. NO.	*	PART NO.	DESCRIPTION	QTY.	REMARKS
		Revision Date	October, 2004		Update In Illustration & Parts List.
1		235732001	NUT - HEX - .25 - 20 - GR8 - YZ	3	
2		510337603	WASHER-FLATSTD-.25-.31X.75-.07-YZ	3	
3		235734001	BOLT-1/4-20X3/4 GR8 ZINC PLTD	3	
4		142410001	CASE-6"X9 XCX X1" OPERATOR MANUAL	1	
5		142954001	CABLE-.068DIA.NYLON CT.-36.00	1	
6		142423001	CRIMP-CABLE (FOR.068DIA.CABLE)	2	
7		105400T90	HDD OPERATIONS & SAFETY VIDEO GUIDEBOOK	1	
8		296266073	MANUAL ASSY-D150X300/300X500 OM MINI CA	1	Inc Ref 5,6, And 8
9		7000B222	DECAL -HORIZONTAL DRILL - RESOURCE LIB.	2	
10		144144001	NOTEBOOK BINDER - 2"-3 XCX	2	
11		144145001	VHS - HOLDER	1	
12		296264888	VIDEO - REMOTE LOCKOUT	1	
13		2326940	DECAL-NOTICE TO OWNERS	1	
14		105400T65	MM - D150X300/300X500 (EN) m1.00	1	
15		105400DCP	PM-D150X300 p1.00	1	
16		105400T09	PM - NAVIGATOR BORING TOOLS p4.00	1	
17		151815001	VHS HOLDER DOUBLE	1	
18		296264887	VIDEO-OPERATIONS/SAFETY HDD&TRKNG EQUIP	1	
19		251803001	VIDEO - DRILL ROD OPERATION AND MAINTENANCE	1	
20		105400T63	OM - D150 X 300/300 X 500 (EN) o1.00	1	
		296266071	D150X300 OPERATIONS LIBRARY		Inc Ref One Of 9, One Of 10, And 11-12, And 17-20
		296266072	D150X300 TECHNICAL LIBRARY		Inc Ref One Of 10, 14 And 16

Decal/Literature Box Assy Fig 1-5

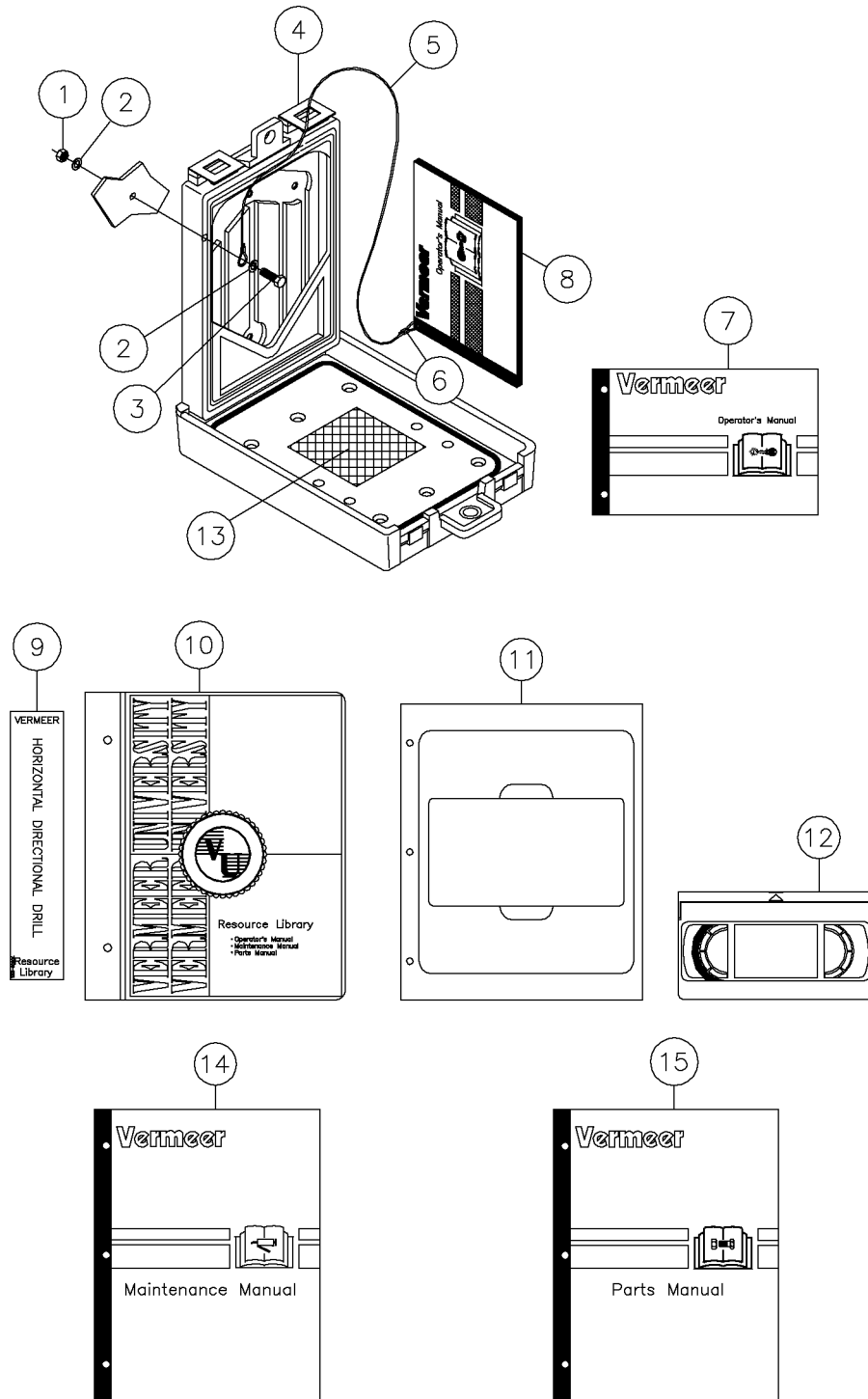

Decal/Literature Box Assy Fig 1-5

REF. NO.	*	PART NO.	DESCRIPTION	QTY.	REMARKS
1		235732001	NUT-1/4-20 GR8 ZINC PLTD	3	
2		510337603	WASHER-FLATSTD-.25-.31X.75-.07-YZ	3	
3		235734001	BOLT-1/4-20X3/4 GR8 ZINC PLTD	3	
4		142410001	CASE-6"X9 XCX X1" OPERATOR MANUAL	1	
5		142954001	CABLE-.068DIA.NYLON CT.-36.00	1	
6		142423001	CRIMP-CABLE (FOR.068DIA.CABLE)	1	
7		105400T63	OM - D150 X 300 (EN) O1.00	1	
8		105400T64	OM - D150 X 300 CABLED (EN) O1.00	1	
9		7000B222	DECAL -HORIZONTAL DRILL - RESOURCE LIB.	1	
10		144144001	NOTEBOOK BINDER - 2"-3 XCX	1	
11		144145001	VHS - HOLDER	1	
12		9572001	VIDEO-FIRE STICK OP. & MAINT.	1	
13		2326940	DECAL-NOTICE TO OWNERS	1	
14		105400T65	MM - D150 X 300 (EN) M1.00	1	
15		105400DCP	PM-D150X300 P1.00	1	

Frame-Mainframe Fig 2-1r02

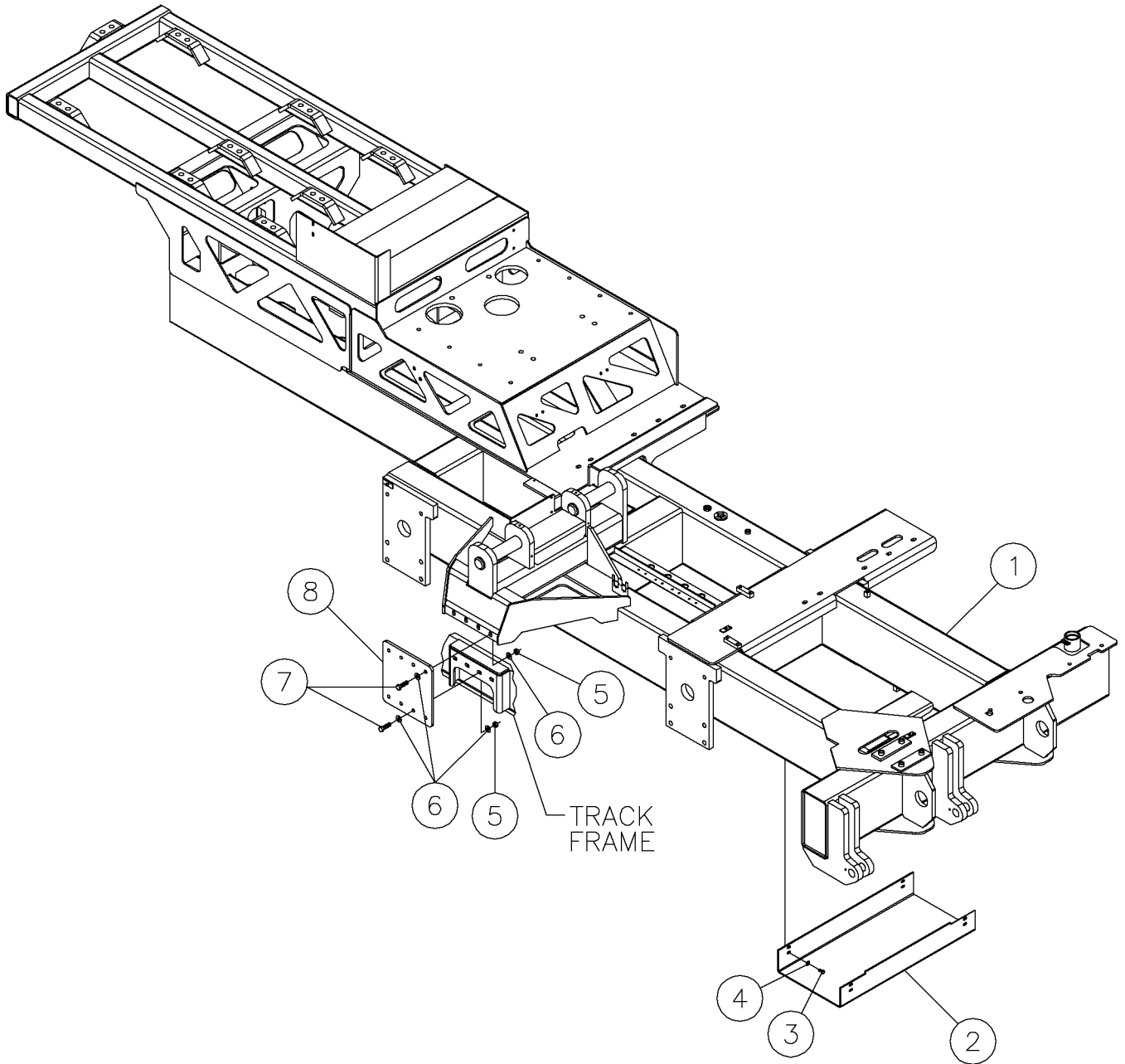

Frame-Mainframe Fig 2-1r02

REF. NO.	*	PART NO.	DESCRIPTION	QTY.	REMARKS
		Revision Date	October, 2004		Update In Illustration & Parts List.
1		296267978	WELDMENT - MAINFRAME	1	
2		296258281	PLATE - SKID PLATE	1	
3		235729001	SCREW-HCS-.50-13X1.00-GR8-YZ	8	
4		235712001	WASHER-1/2 SAE HARD ZINC PLTD - Replaced by 485025	8	
5		235739001	NUT-3/4-10 GR8 ZINC PLTD	8	
6		510337617	WASHER-FLATSTD-.75-.81X2.00-.15-YZ	16	
7		288880001	SPACER - BAR	8	
8		296266961	PLATE - RACK PIV BRACE	1	

Frame-Mainframe Fig 2-1r01

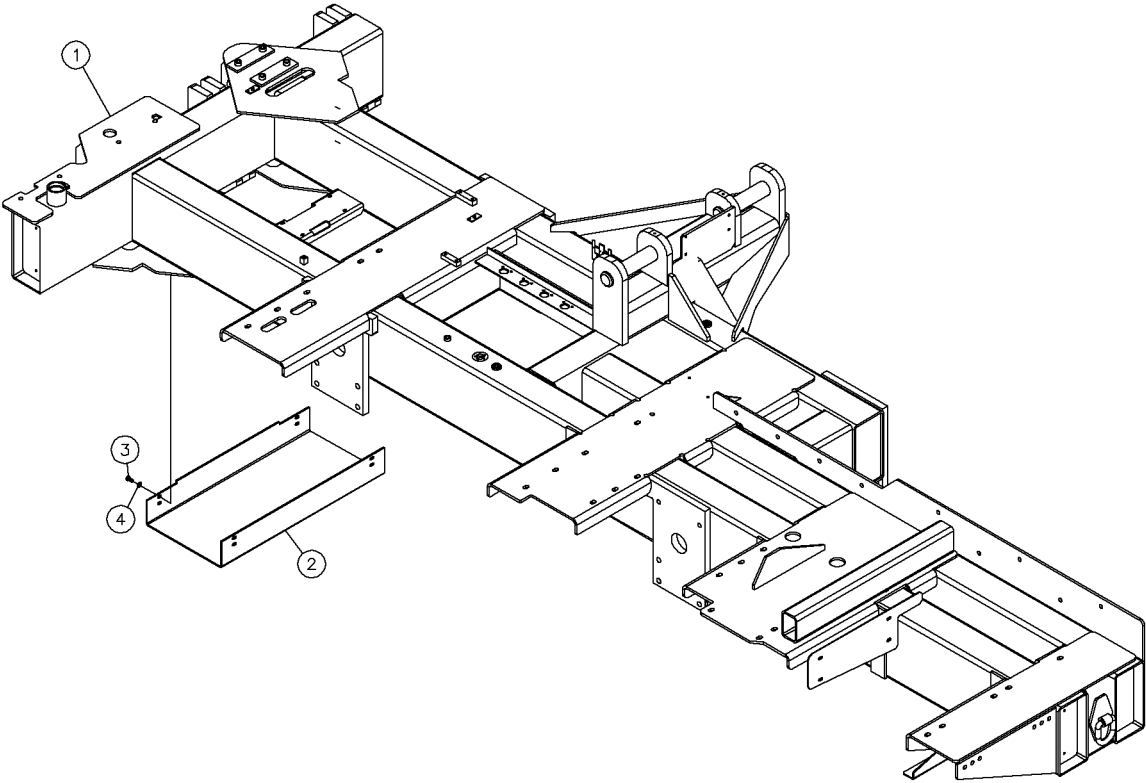

Frame-Mainframe Fig 2-1r01

REF. NO.	*	PART NO.	DESCRIPTION	QTY.	REMARKS
		Revision Date	June, 2002		Add Parts
1		293514001	FRAME WELDMENT	1	
2	*	296258281	PLATE - SKID PLATE	1	
3	*	235729001	SCREW-HCS-.50-13X1.00-GR8-YZ	8	
4	*	235712001	WASHER-1/2 SAE HARD ZINC PLTD - Replaced by 485025	8	

Frame-Mainframe Fig 2-1

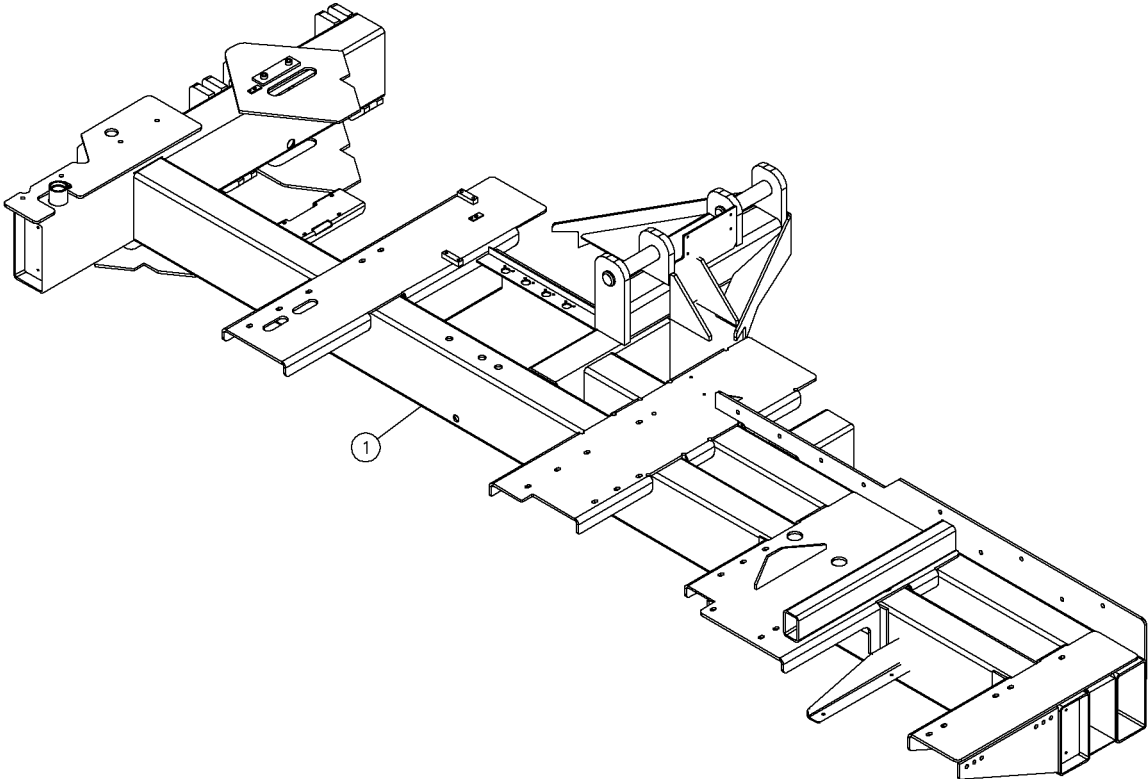

Frame-Mainframe Fig 2-1

REF. NO.	*	PART NO.	DESCRIPTION	QTY.	REMARKS
1		293514001	FRAME WELDMENT	1	

Frame-Rack Assy Fig 2-2r02

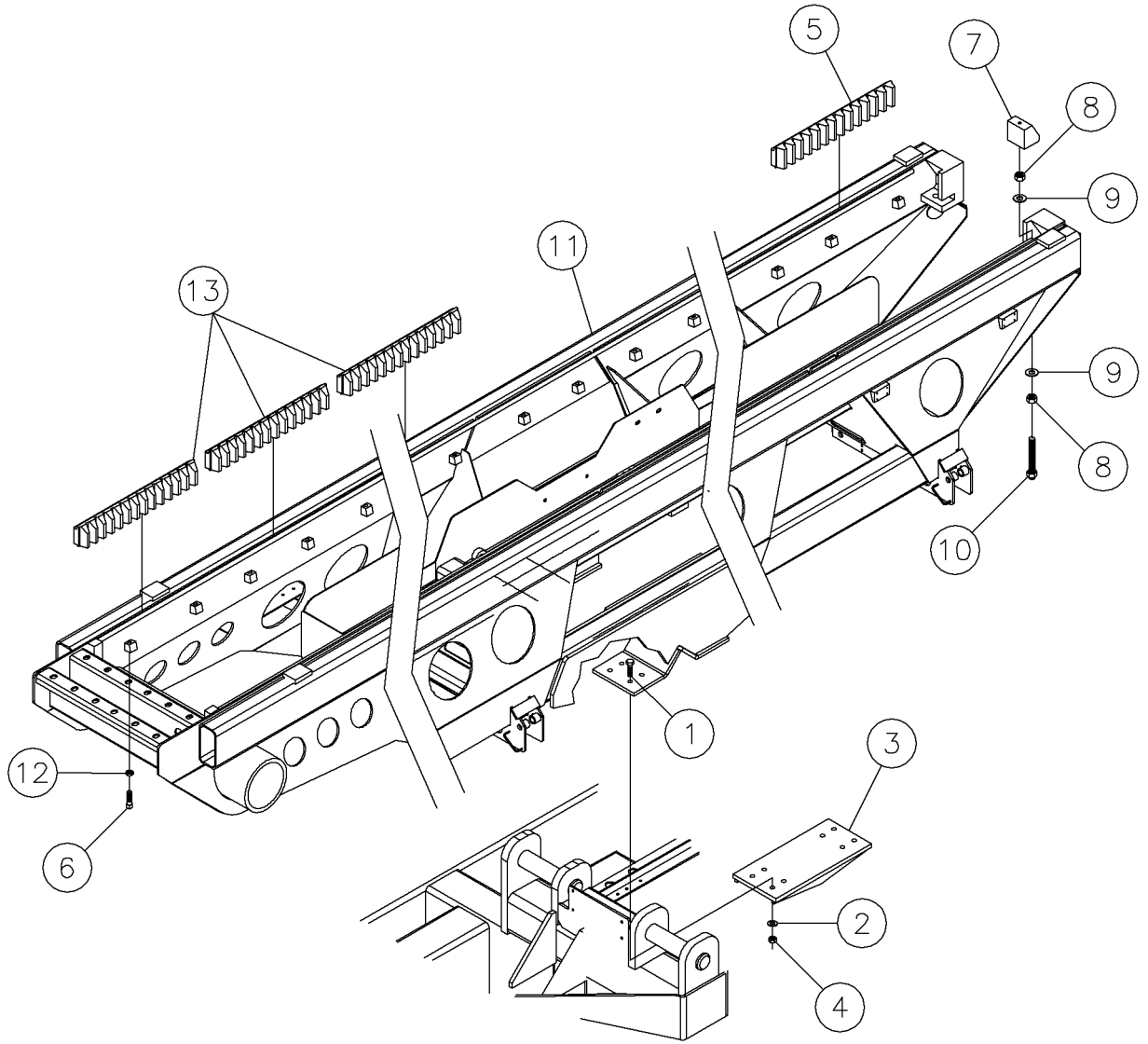

Frame-Rack Assy Fig 2-2r02

REF. NO.	*	PART NO.	DESCRIPTION	QTY.	REMARKS
		Revision Date	October, 2004		Update In Illustration & Parts List.
1		238880001	BOLT-3/4-10X2 1/2 HHCS GR8 ZY	16	
2		235717001	WASHER-3/4 FLAT HARDENED YELLOW ZINC	16	
3		292839001	PLATE - PIVOT	2	
4		235739001	NUT-3/4-10 GR8 ZINC PLTD	16	
5		277853001	RACK - 16 MODULE, 4" FACE, 20DEGREES	36	
6		159881001	SQ HSS-3/4-10X3 ZNC PLT	84	
7		277967001	WEDGE - RACK TIGHTENER	2	
8		436001	NUT-1 NC HEX	4	
9		85759001	WASHER-1"HARDEN ASTM-A325	4	
10		296258290	ROD - WEDGE ADJUSTMENT	2	
11		292846001	RACK WELDMENT	1	
12		510320311	NUT-HEXJAM-.75-10-GR2-YZ	84	
13		296264104	RACK - SEGMENT -CHAMFER	6	

Frame-Rack Assy Fig 2-2r01

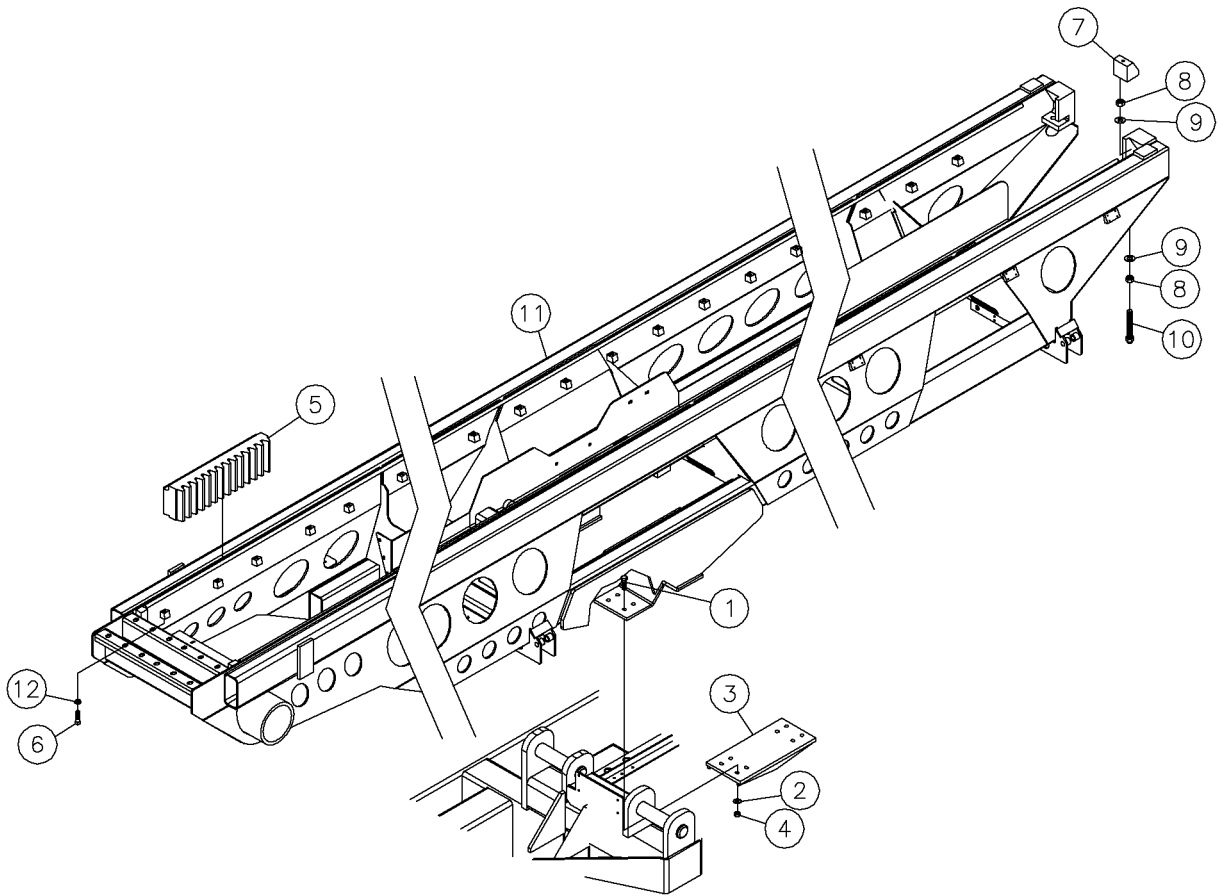

Frame-Rack Assy Fig 2-2r01

REF. NO.	*	PART NO.	DESCRIPTION	QTY.	REMARKS
		Revision	June, 2002		
1		238880001	BOLT-3/4-10X2 1/2 HHCS GR8 ZY	16	
2		235717001	WASHER-3/4 FLAT HARDENED YELLOW ZINC	16	
3		292839001	PLATE - PIVOT	2	
4		235739001	NUT-3/4-10 GR8 ZINC PLTD	16	
5		277853001	RACK - 16 MODULE - 4" FACE	42	
6	*	159881001	SQ HSS-3/4-10X3 ZNC PLT	84	
7		277967001	ROD - WEDGE ADJUSTMENT	2	
8		436001	NUT-1 NC HEX	4	
9		85759001	WASHER-1"HARDEN ASTM-A325	4	
10		296258290	ROD - WEDGE ADJUSTMENT	2	
11		292846001	RACK WELDMENT	1	
12		510320311	NUT-HEXJAM-.75-10-GR2-YZ	84	

Frame-Rack Assy Fig 2-2

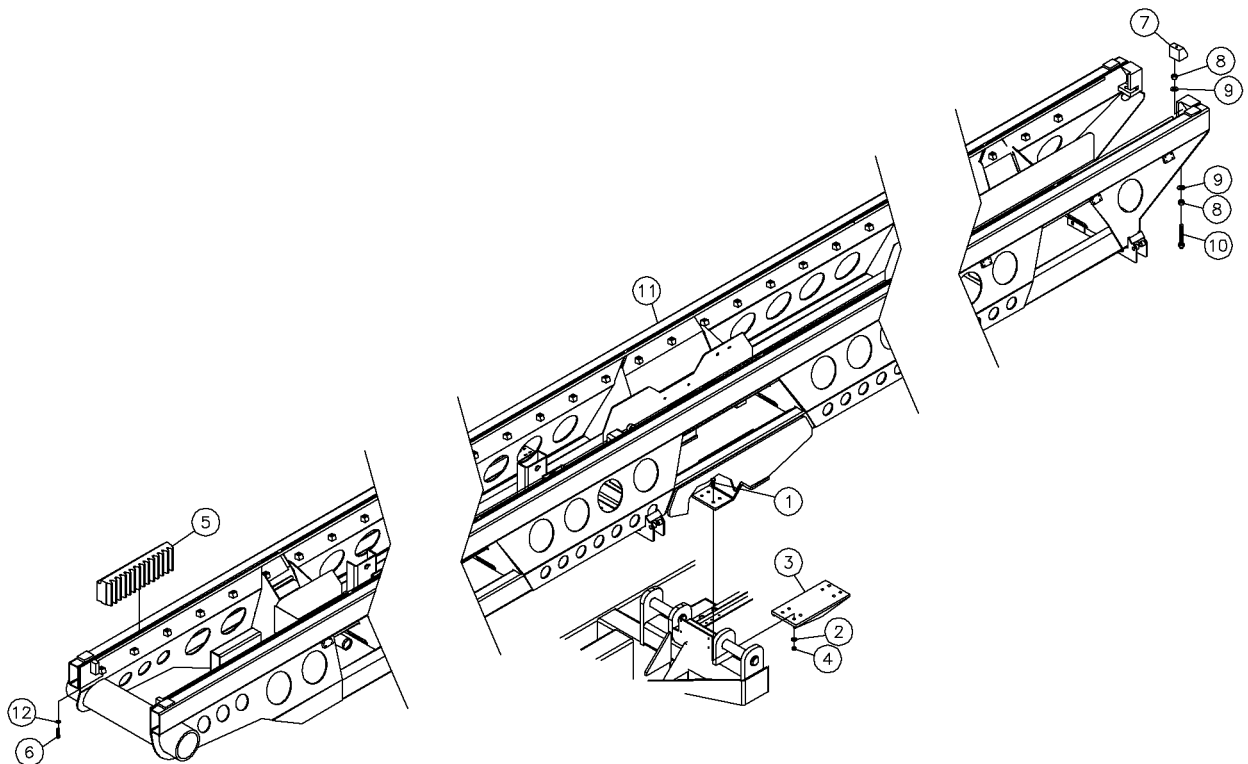

Frame-Rack Assy Fig 2-2

REF. NO.	*	PART NO.	DESCRIPTION	QTY.	REMARKS
1		238880001	BOLT-3/4-10X2 1/2 HHCS GR8 ZY	16	
2		235717001	WASHER-3/4 FLAT HARDENED YELLOW ZINC	16	
3		292839001	PLATE - PIVOT	2	
4		235739001	NUT-3/4-10 GR8 ZINC PLTD	16	
5		277853001	RACK - 16 MODULE - 4" FACE	42	
6		552024	SCREW-3/4-10X2 1/2 SQ.HD.CUPPT	84	
7		277967001	ROD - WEDGE ADJUSTMENT	2	
8		436001	NUT-1 NC HEX	4	
9		85759001	WASHER-1"HARDEN ASTM-A325	4	
10		296258290	ROD - WEDGE ADJUSTMENT	2	
11		292846001	RACK WELDMENT	1	
12		510320311	NUT-HEXJAM-.75-10-GR2-YZ	84	

Frame-Track Frame Assy Fig 2-3r01

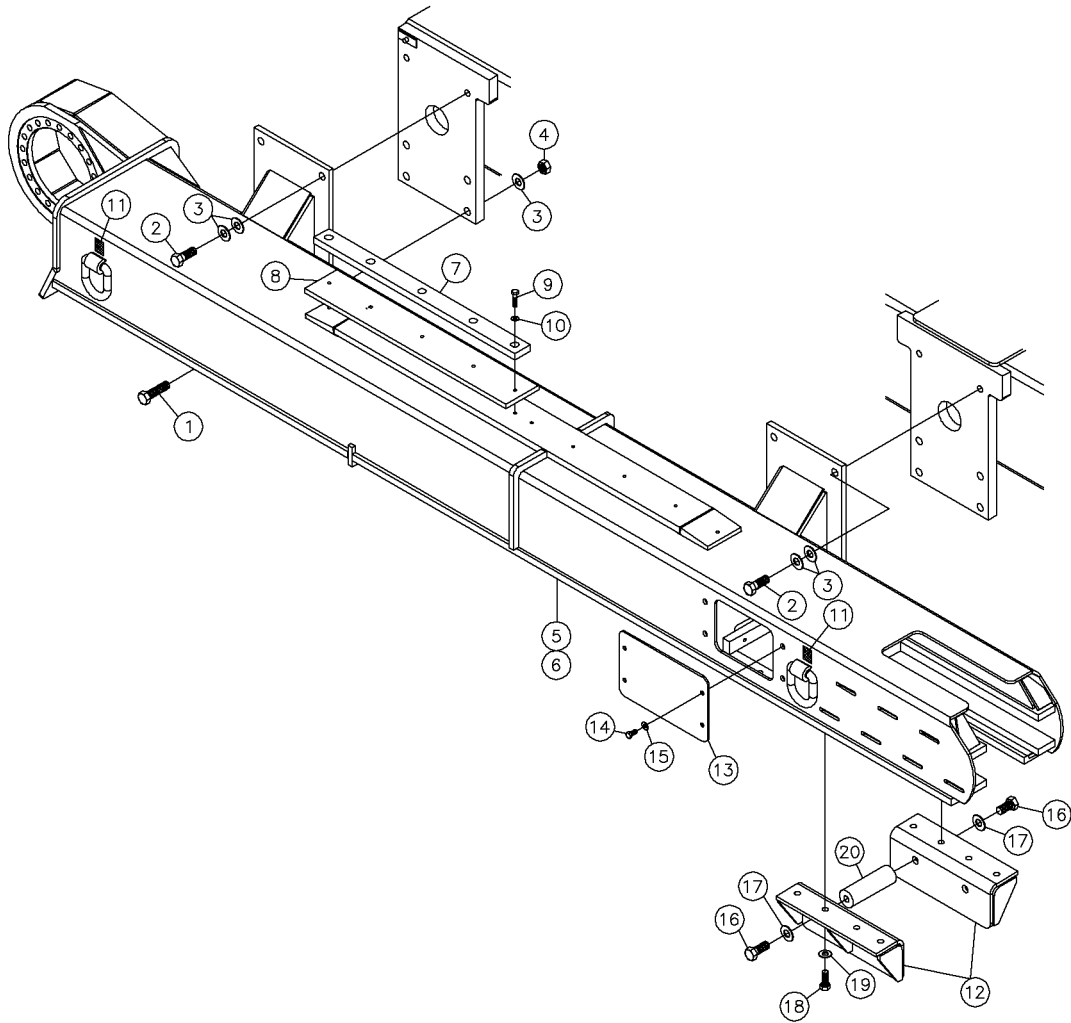

Frame-Track Frame Assy Fig 2-3r01

REF. NO.	*	PART NO.	DESCRIPTION	QTY.	REMARKS
		Revision Date	October, 2004		Update In Illustration & Parts List.
1		388034	BOLT-1-UNCX3 1/2 GR.8 HEX	16	
2		388024	BOLT-1-UNCX2 1/2 GR.8 HEX	8	
3		238892001	WASHER-1" HARDENED FLAT ZY	32	
4		238215001	NUT 1-8 GR8 ZINC YC	16	
5		296267966	FRAME D - 150 RIGHT TRACK	1	
6		296267967	FRAME - D150 RACK SIDE TRACK	1	
7		96927001	BAR-CHAIN WEAR	4	
8		97290001	TRACK-CHAIN SLIDE	4	
9		235723001	SCREW - HCS -.38 - 16 X 1.50 - GR8 - YZ	20	
10		510337635	WASHER-FLATSAE-.38-.41X.81-16G-YZ	20	
11		70001834	DECAL - TIE DOWN POINT	4	
12		296267845	TRACK CHAIN GUIDE - RIGHT	4	
13		296267827	PLATE - ACCESS COVER	1	
14		235729001	SCREW-HCS-.50-13X1.00-GR8-YZ	8	
15		485025	WASHER-1/2 FLAT-HARDENED-YZ	4	
16		249719001	BOLT-1-8 X 2.00 GR8 HEX YZ	2	
17		238892001	WASHER-1" HARDENED FLAT ZY	2	
18		235746001	BOLT-3/4-10X2 GR8 HEX ZNC PLTD	16	
19		235717001	WASHER-3/4 FLAT HARDENED YELLOW ZINC	16	
20		296267847	SPACER - TRACK CHAIN GUIDE	2	

Frame-Track Frame Assy Fig 2-3

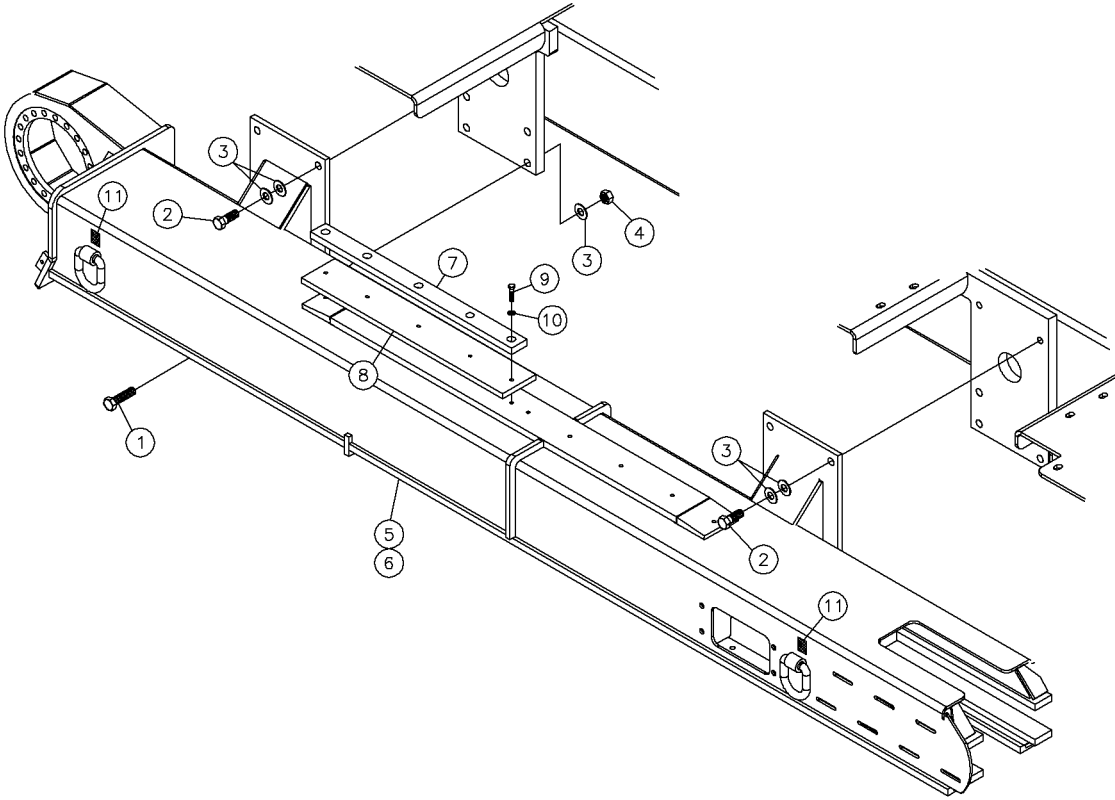

Frame-Track Frame Assy Fig 2-3

REF. NO.	*	PART NO.	DESCRIPTION	QTY.	REMARKS
1		388034	BOLT-1-UNCX3 1/2 GR.8 HEX	16	
2		388024	BOLT-1-UNCX2 1/2 GR.8 HEX	8	
3		238892001	WASHER-1" HARDENED FLAT ZY	32	
4		238215001	NUT 1-8 GR8 ZINC YC	16	
5		292943001	TRACK-ENGINE SIDE	1	
6		296002001	TRACK-RACK SIDE	1	
7		96927001	BAR-CHAIN WEAR	4	
8		97290001	TRACK-CHAIN SLIDE	4	
9		235723001	BOLT-3/8-16X1 1/2 GR8 ZINC PLT	20	
10		510337635	WASHER-FLATSAE-.38-.41X.81-16G-YZ	20	
11		70001834	DECAL - TIE DOWN POINT	4	

Frame-Track Drive Gearbox/Sprocket Assy Fig 2-4

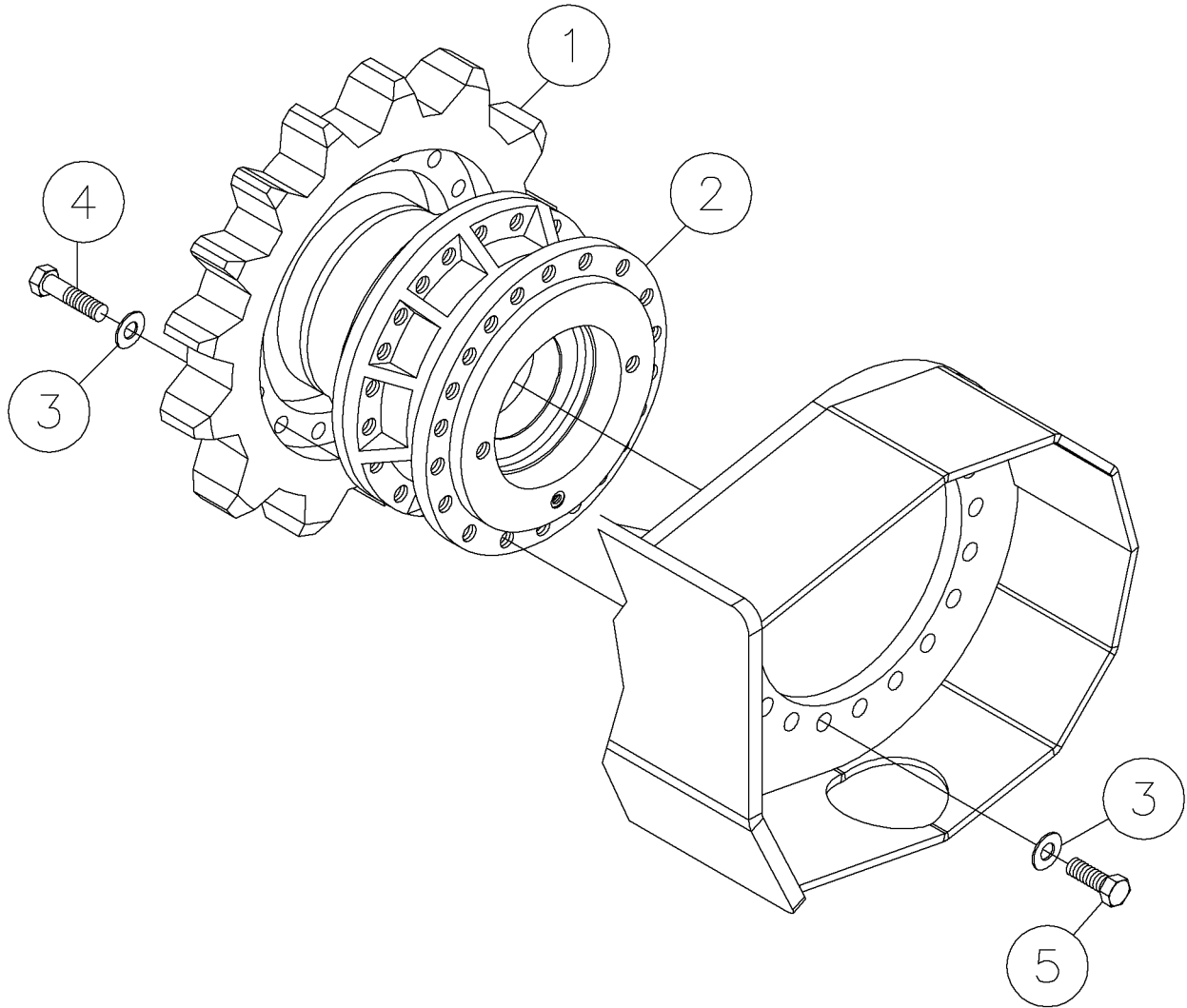

Frame-Track Drive Gearbox/Sprocket Assy Fig 2-4

REF. NO.	*	PART NO.	DESCRIPTION	QTY.	REMARKS
1		601950001	SPROCKET-21T TRACK	2	
2		602464001	PLANETARY-TRACK DRIVE	2	Breakdown Fig 12-22
3		85979001	WASHER-3/4"HARDEN ASTM-A325	80	
4		122614001	BOLT- M20 X 1.5 X 80MM HEX HD	40	
5		122613001	BOLT-M20 X 1.5X55MM HEX HD	40	

Frame-Track Tension Assy Fig 2-5r02

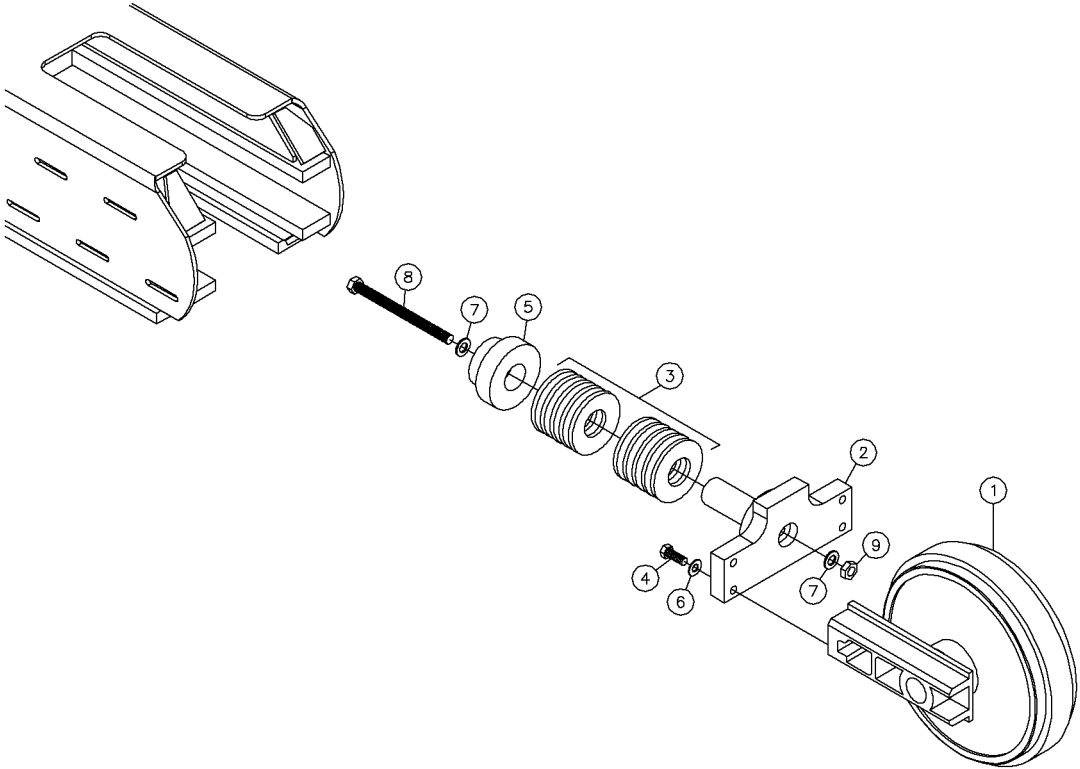

Frame-Track Tension Assy Fig 2-5r02

REF. NO.	*	PART NO.	DESCRIPTION	QTY.	REMARKS
		Revision Date	October, 2004		Update In Illustration & Parts List.
1		607915001	ROLLER-IDLER WITH BRACKETS	2	Breakdown Fig 12-23
2		296267830	MOUNT - TRACK IDLER	2	
3		616371001	WASHER- BELLVILLE 2.26 ID X 5.25 OD	20	
4		508478060	SCREW-HCS,M16-2.00X60,10.9,YZ,ISO4014,PT	4	
5		616397001	BOSS TRACK RECOIL	2	
6		85706001	WASHER-5/8 HARDEN	4	
7		85979001	WASHER-3/4"HARDEN ASTM-A325	4	
8		385100	BOLT-3/4-10NCX10 GR.8 HEX	2	
		296267863	ASSEMBLY - END IDLER TENSIONER		Inc Ref 2-3, 5, And 7-9

Frame-Track Tension Assy Fig 2-5r01

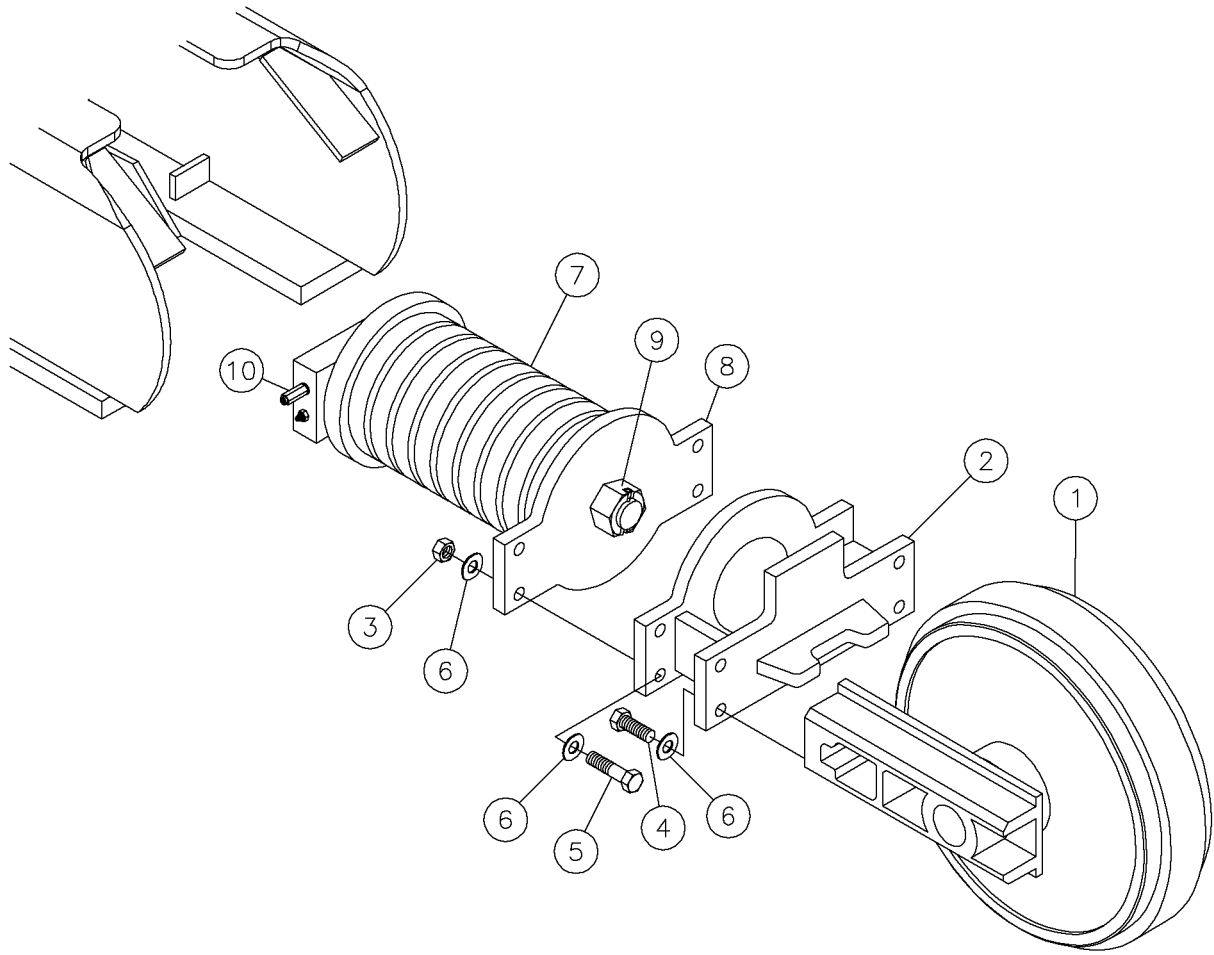

Frame-Track Tension Assy Fig 2-5r01

REF. NO.	*	PART NO.	DESCRIPTION	QTY.	REMARKS
		Revision Date	June, 2002		Add Items
1		607915001	ROLLER-IDLER WITH BRACKETS	2	Breakdown Fig 12-23
2		241710001	YOKE - TRACK TENSION	2	
3		75385001	NUT-5/8-UNC GR.8 HEX	8	
4		64125001	BOLT-M16X45 GR.8.8	4	
5		27169024	BOLT-5/8-11NCX2 1/2 GR.8 HEX	4	
6		85706001	WASHER-5/8 HARDEN	24	
7		605240001	ASSEMBLY-TRACK SPRING TENSION	1	
8	*	96980001	PLATE-TENSION	2	
9	*	97040001	NUT	2	
10	*	1788017	PIN - EXPANSION 5-16 X 2 1/2 REF T09776	2	

Frame-Track Tension Assy Fig 2-5

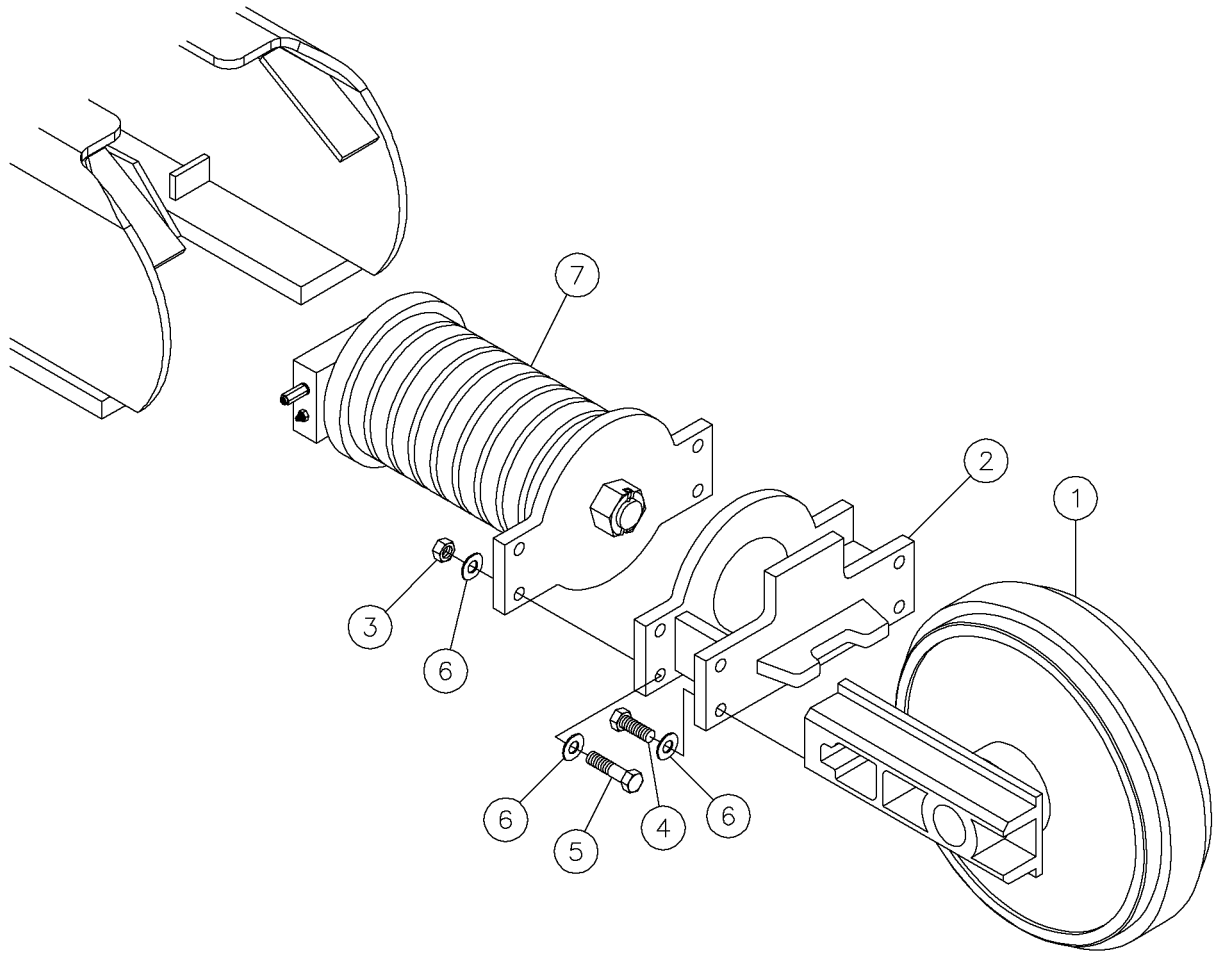

Frame-Track Tension Assy Fig 2-5

REF. NO.	*	PART NO.	DESCRIPTION	QTY.	REMARKS
1		607915001	ROLLER-IDLER WITH BRACKETS	2	Breakdown Fig 12-23
2		241710001	YOKE - TRACK TENSION	2	
3		75385001	NUT-5/8-UNC GR.8 HEX	8	
4		64125001	BOLT-M16X45 GR.8.8	4	
5		27169024	BOLT-5/8-11NCX2 1/2 GR.8 HEX	4	
6		85706001	WASHER-5/8 HARDEN	24	
7		605240001	ASSEMBLY-TRACK SPRING TENSION	1	

Frame-Track Chain & Roller Assy Fig 2-6

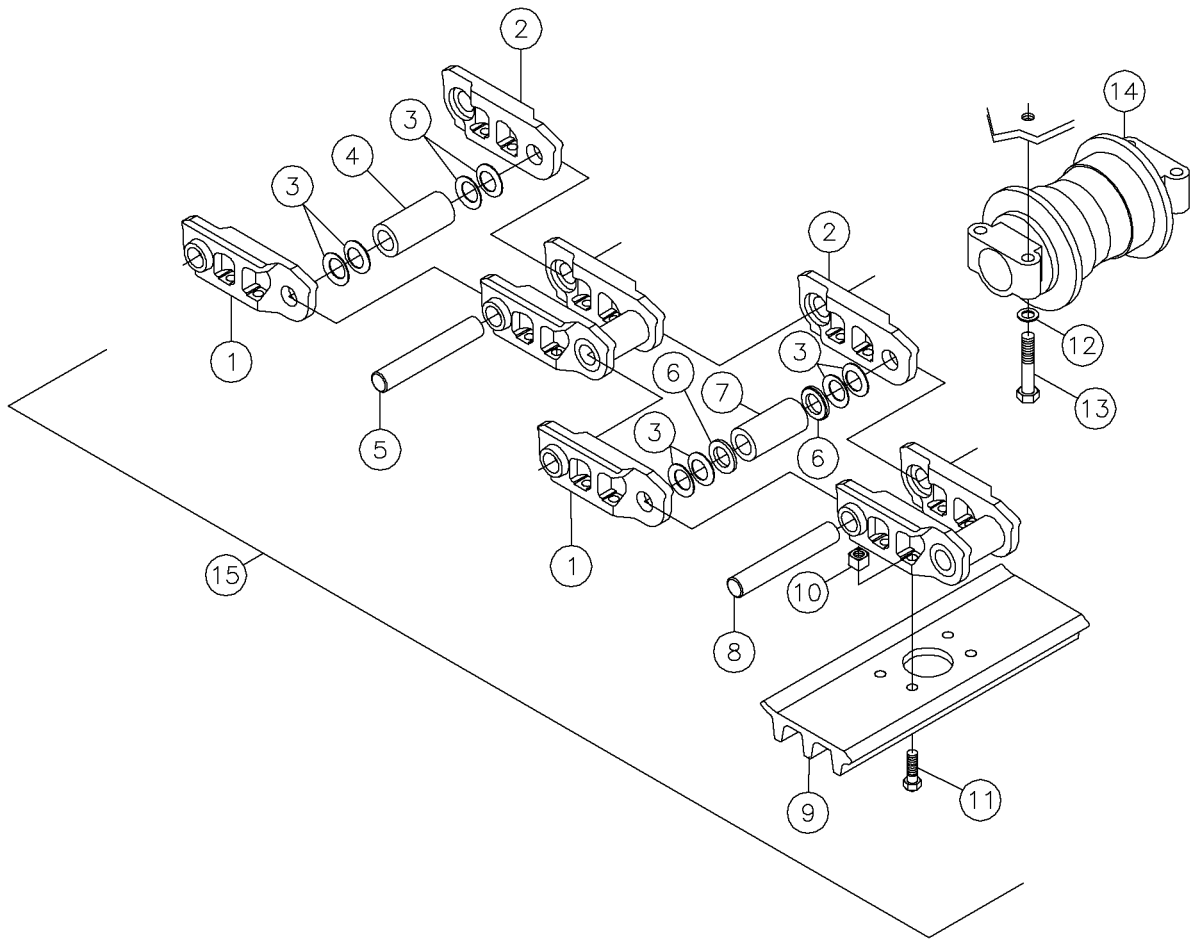

Frame-Track Chain & Roller Assy Fig 2-6

REF. NO.	*	PART NO.	DESCRIPTION	QTY.	REMARKS
1		98694011	TRACK LINK-RH	61	
2		98694013	TRACK LINK-LH	61	
3		98694005	WASHER-SEAL	244	
4		604638001	BUSHING	60	
5		604639001	PIN	60	
6		98694003	WASHER-SEAL	2	
7		98694015	MASTER BUSHING	1	
8		604640001	MASTER PIN	1	
9		103052003	PAD-STEEL TRACK (TRIPLE GRO.)	61	
10		78549003	BOLT-TRACK SHOE	244	
11		78549009	NUT-TRACK SHOE	244	
12		235715001	WASHER-5/8 SAE HARD ZINC PLTD	88	
13		27169034	BOLT-5/8-11NCX3 1/2 GR.8 HEX	88	
14		901600001	ROLLER-TRACK D4 7T6395	26	Breakdown Fig 12-21
15		296261517	CHAIN - TRACK D45IP W/STL PADS (LUBRICATED)	2	Inc Ref No's 1-11

Frame-Catwalk Assy Fig 2-7r02

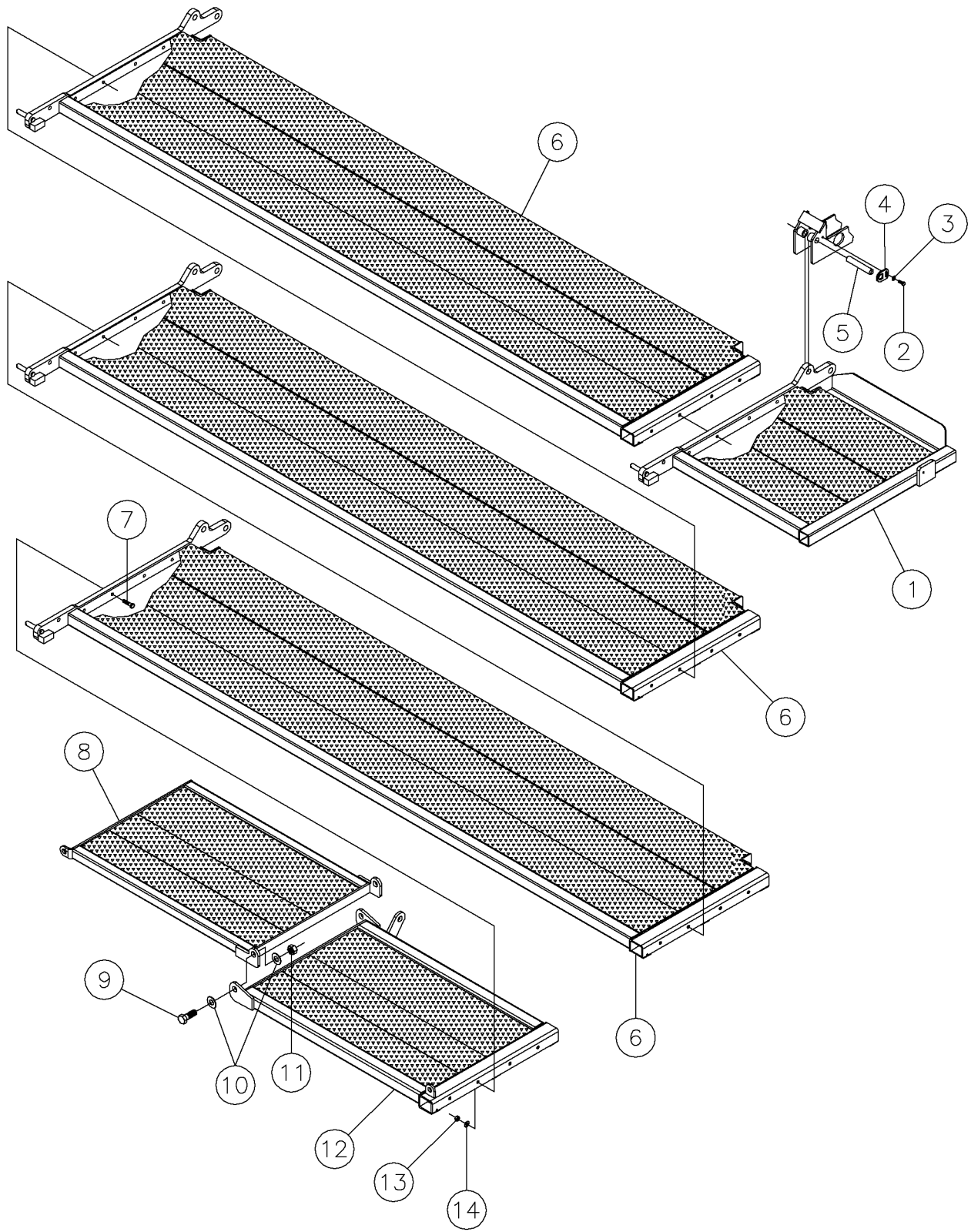

Frame-Catwalk Assy Fig 2-7r02

REF. NO.	*	PART NO.	DESCRIPTION	QTY.	REMARKS
		Revision Date	October, 2004		Update In Illustration & Parts List.
1		296262730	CATWALK - REAR END SECTION	1	
2		235727001	BOLT-3/8-16X1 GR8 HEX ZINC PLT	4	
3		235713001	WASHER - FLATSTRL - .38 - .41 X .81 - .06-YA-A325	4	
4		277961001	PLATE - PIN RETAINER	4	
5		277960001	PIN - 1" X 5.25"	4	
6		296266779	CATWALK - MIDSECTION	3	
7		235718001	BOLT-1/2-13X2 GR8 HEX ZINC PLT	16	
8		296261513	CARRIER - PIVOT	1	
9		388024	BOLT-1-UNCX2 1/2 GR.8 HEX	2	
10		238892001	WASHER-1" HARDENED FLAT ZY	4	
11		238215001	NUT 1-8 GR8 ZINC YC	2	
12		296261514	CATCH - FRONT	1	
13		235731001	NUT-1/2-13 GR8 ZINC PLTD	16	
14		485025	WASHER-1/2 FLAT-HARDENED-YZ	16	

Frame-Catwalk Assy Fig 2-7r01

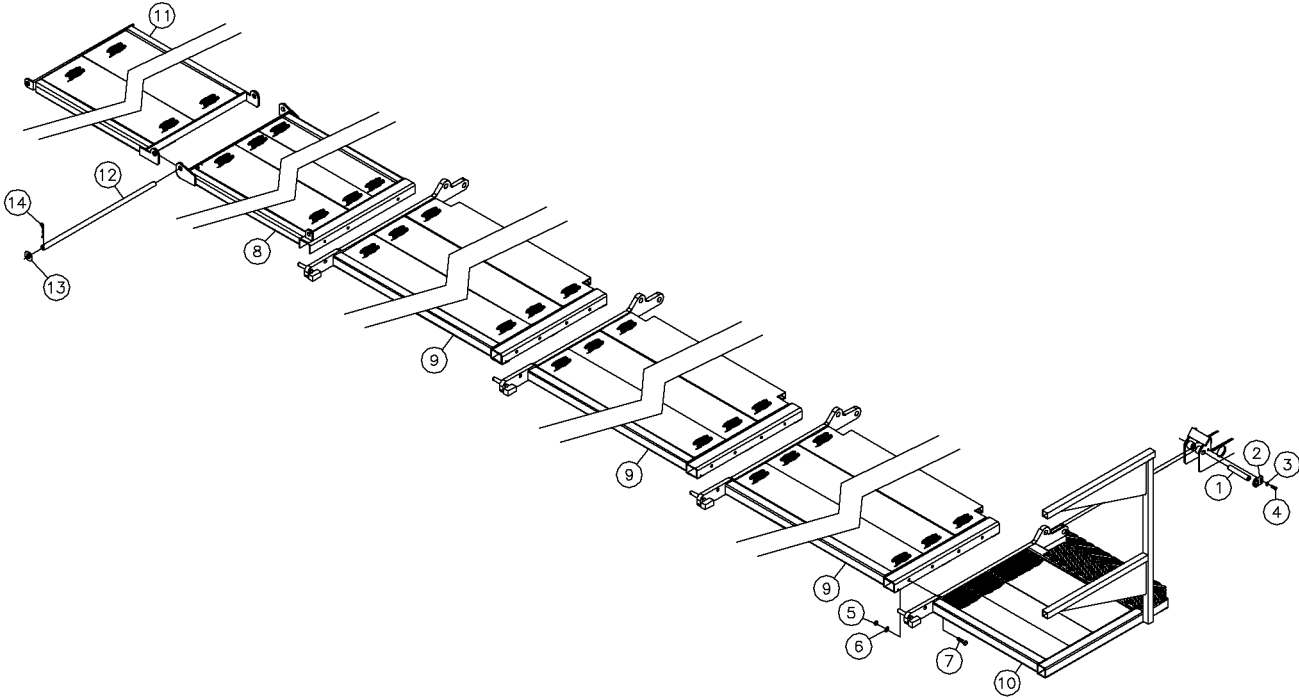

Frame-Catwalk Assy Fig 2-7r01

REF. NO.	*	PART NO.	DESCRIPTION	QTY.	REMARKS
		Revision Date	June, 2002		Update In Illustration.
1		277960001	PIN - 1" X 5.25"	4	
2		277961001	PLATE - PIN RETAINER	4	
3		235713001	WASHER-3/8 SAE HARD ZINC PLTD	4	
4		235727001	BOLT-3/8-16X1 GR8 HEX ZINC PLT	4	
5		235731001	NUT-1/2-13 GR8 ZINC PLTD	16	
6		485025	WASHER-1/2 FLAT-HARDENED-ZINC	16	
7		235718001	BOLT-1/2-13X2 GR8 HEX ZINC PLT	16	
8		296261514	CATCH - FRONT	1	
9	*	288328001	CATWALK - MIDSECTION	3	
10	*	288327001	CATWALK - UPPER SECTION	1	
11		296261513	CARRIER - PIVOT	1	
12		296261511	ROD - CATWALK PIVOT	1	
13		70059001	WASHER-2 1/2ODX1 1/16ID-.136/	2	
14		20667001	HAIR PIN COTTER - .177 WIRE	2	

Frame-Catwalk Assy Fig 2-7

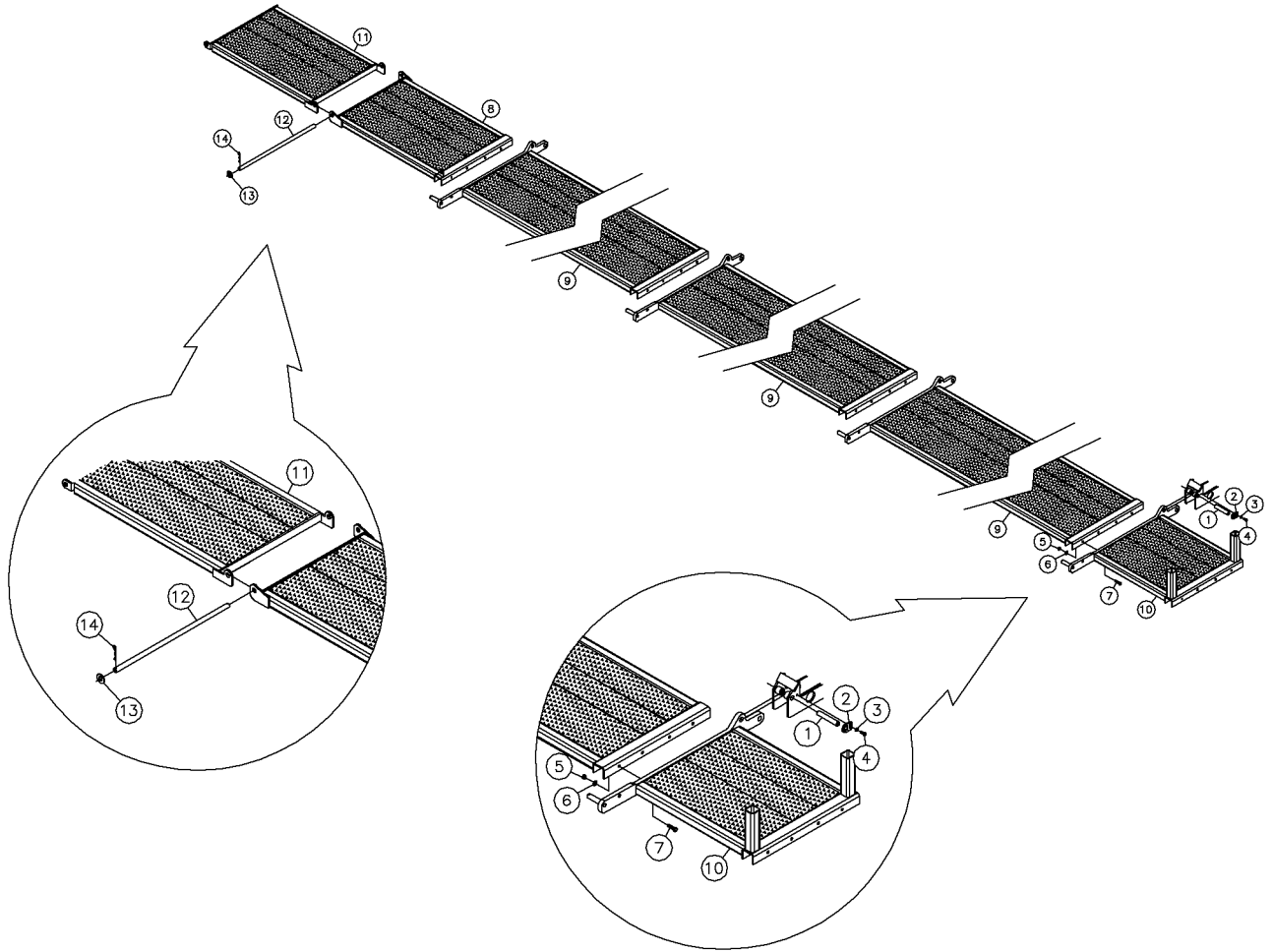

Frame-Catwalk Assy Fig 2-7

REF. NO.	*	PART NO.	DESCRIPTION	QTY.	REMARKS
1		277960001	PIN - 1" X 5.25"	4	
2		277961001	PLATE - PIN RETAINER	4	
3		235713001	WASHER-3/8 SAE HARD ZINC PLTD	4	
4		235727001	BOLT-3/8-16X1 GR8 HEX ZINC PLT	4	
5		235731001	NUT-1/2-13 GR8 ZINC PLTD	16	
6		485025	WASHER-1/2 FLAT-HARDENED-ZINC	16	
7		235718001	BOLT-1/2-13X2 GR8 HEX ZINC PLT	16	
8		296261514	CATCH - FRONT	1	
9		288328001	CATWALK - MIDSECTION	3	
10		288327001	CATWALK - UPPER SECTION	1	
11		296261513	CARRIER - PIVOT	1	
12		296261511	ROD - CATWALK PIVOT	1	
13		70059001	WASHER-2 1/2ODX1 1/16ID-.136/	2	
14		20667001	HAIR PIN COTTER - .177 WIRE	2	

Frame-Catwalk Handrail Assy Fig 2-8r01

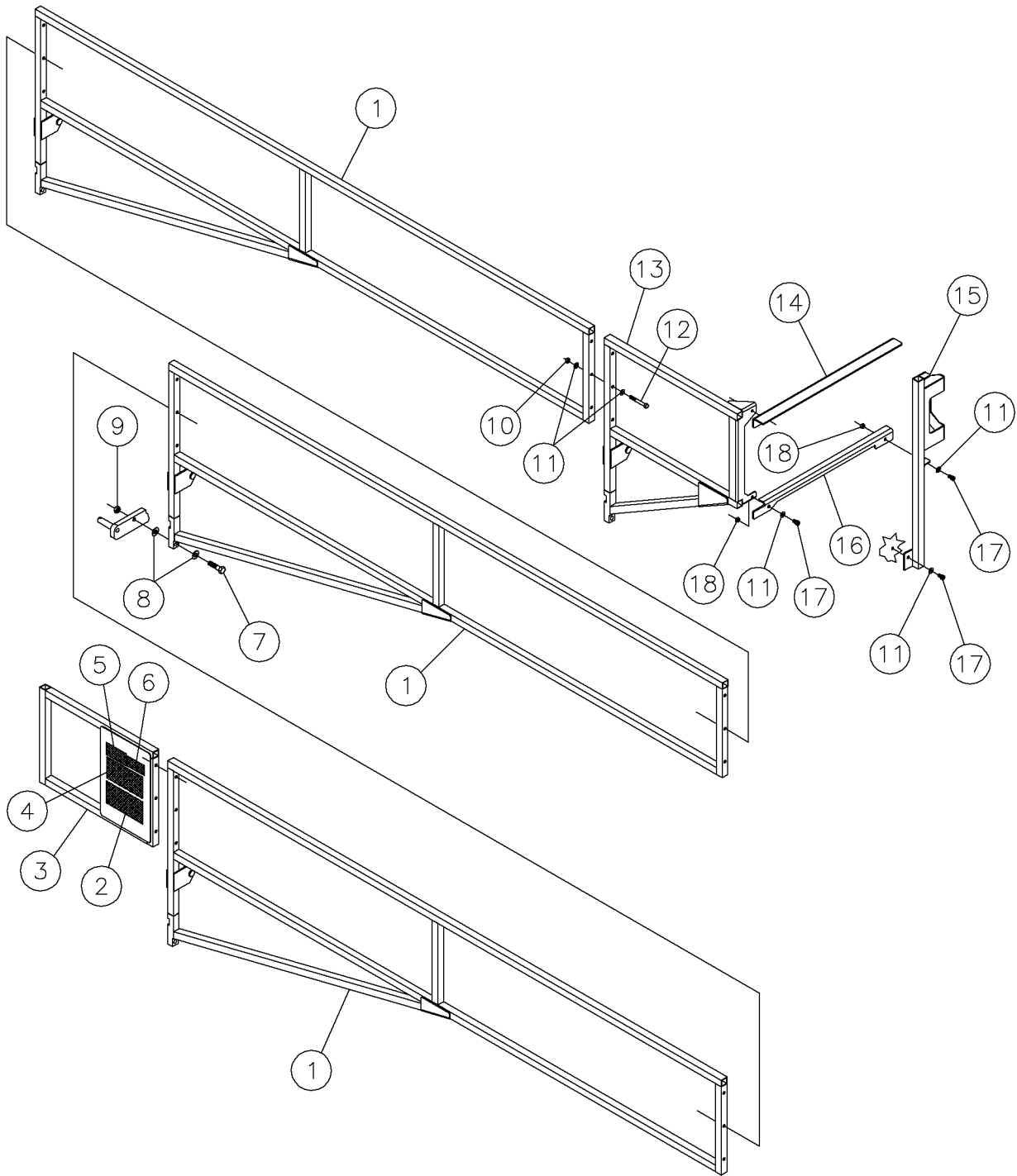

Frame-Catwalk Handrail Assy Fig 2-8r01

REF. NO.	*	PART NO.	DESCRIPTION	QTY.	REMARKS
		Revision Date	October, 2004		Update In Illustration & Parts List.
1		296266785	HANDRAIL - MIDSECTION	1	
2		7000B617	DECAL - DANGER POWER LINES	1	Domestic
		700IB617	DECAL - DANGER POWER LINES	1	International
3		288332001	HANDRAIL - LOWER SECTION	1	
4		7000B623	DECAL - DANGER ELECTRIC SHOCK	1	Domestic
		700IB623	DECAL - DANGER ELECTRIC SHOCK	1	International
5		7000B702	DECAL - DANGER - FALLING LOAD	1	Domestic
		700IB702	DECAL - DANGER - FALLING LOAD	1	International
6		7000B622	DECAL - WARNING NO RIDERS	1	Domestic
		700IB622	DECAL - WARNING NO RIDERS	1	International
7		238242001	BOLT 3/4"-10 X 3" GR8 HEX Y/Z	4	
8		235717001	WASHER-3/4 FLAT HARDENED YELLOW ZINC	8	
9		510320311	NUT-HEXJAM-.75-10-GR2-YZ	4	
10		235731001	NUT-1/2-13 GR8 ZINC PLTD	12	
11		485025	WASHER-1/2 FLAT-HARDENED-YZ	29	
12		238244001	BOLT 1/2"-13 X 4"GR8 HEX Y/ZIN	12	
13		296262704	HANDRAIL - UPPER SECTION	1	
14		296262703	ARM-UPPER HANDRAIL LINKAGE	1	
15		296262699	POST - HANDRAIL LINKAGE	1	
16		296262702	ARM - LOWER HANDRAIL EXT	1	
17		296256038	SCREW - SHSS - .50X.38-.38-16 THD-CZ	5	
18		250508001	NUT - 3/8-NC Gr8 TOP LOCK Y/ZINC	4	

Frame-Catwalk Handrail Assy Fig 2-8

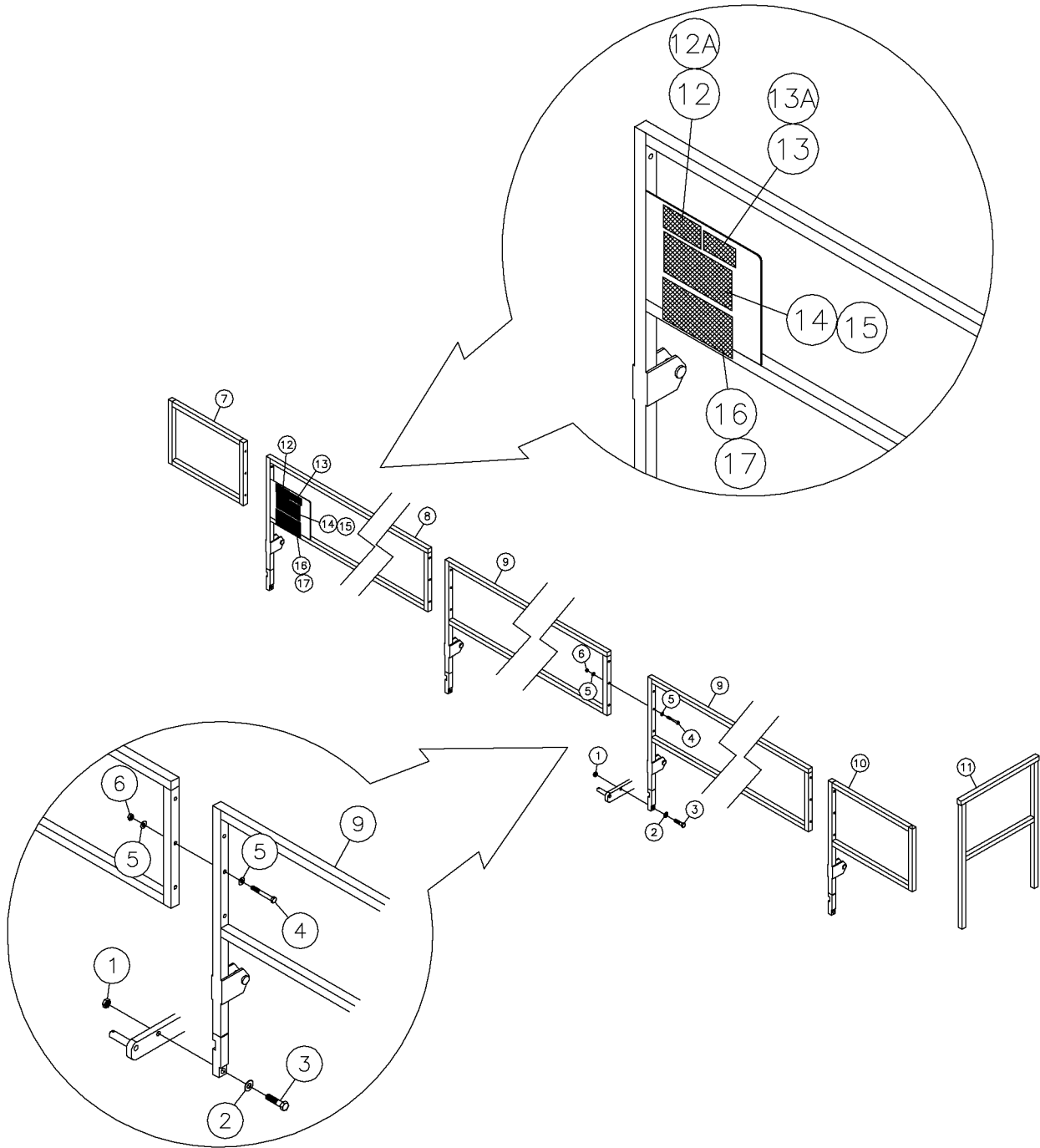

Frame-Catwalk Handrail Assy Fig 2-8

REF. NO.	*	PART NO.	DESCRIPTION	QTY.	REMARKS
1		510320311	NUT-HEXJAM-.75-10-GR2-YZ	4	
2		235717001	WASHER-3/4 FLAT HARDENED YELLOW ZINC	4	
3		238242001	BOLT 3/4"-10 X 3" GR8 HEX Y/Z	4	
4		238244001	BOLT 1/2"-13 X 4"GR8 HEX Y/ZIN	12	
5		485025	WASHER-1/2 FLAT-HARDENED-ZINC	24	
6		235731001	NUT-1/2-13 GR8 ZINC PLTD	12	
7		288332001	HANDRAIL - LOWER SECTION	1	
8		288331001	HANDRAIL - MIDSECTION	1	
9		296261522	HANDRAIL - MIDSECTION	2	
10		288330001	HANDRAIL - UPPER SECTION	1	
11		288333001	HANDRAIL - END SECTION	1	
12		700IB702	DECAL - DANGER - FALLING LOAD	1	
12A		700IB702	DECAL - DANGER - FALLING LOAD	1	International
13		7000B622	DECAL - WARNING NO RIDERS	1	
13A		700IB622	DECAL - WARNING NO RIDERS	1	International
14		7000B623	DECAL - DANGER ELECTRIC SHOCK	1	
15		700IB623	DECAL - DANGER ELECTRIC SHOCK	1	International
16		7000B617	DECAL - DANGER POWER LINES	1	
17		700IB617	DECAL - DANGER POWER LINES	1	International

Frame-Rotation Gearbox/Carriage Assy Fig 2-9r02

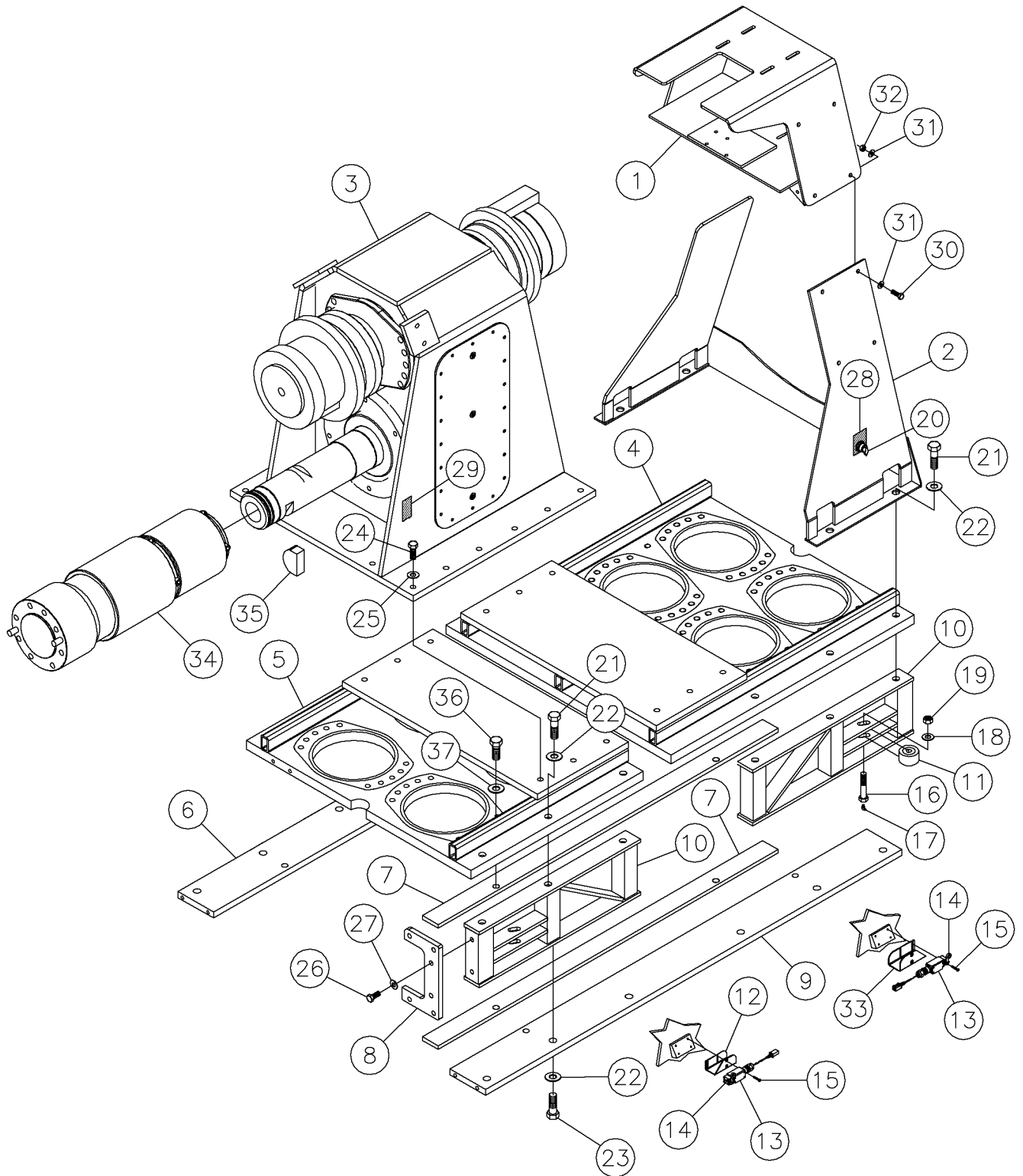

Frame-Rotation Gearbox/Carriage Assy Fig 2-9r02

REF. NO.	*	PART NO.	DESCRIPTION	QTY.	REMARKS
		Revision Date	October, 2004		Update In Illustration & Parts List.
1		288443001	VALVE - MOUNT HOSE CARRIER	1	
2		288444001	HOUSING HOSE CARRIER	1	
3		288481001	GEAR BOX HEAD ASSEMBLY	1	Breakdown Fig. 2-10
4		277925001	FRAME - GEARBOX CARRIAGE	1	
5		277934001	FRAME GEARBOX CARRIAGE	1	
6		288312001	BAR - BRIDGE SLIDE	1	
7		288311001	SLIDE - GEARBOX D150X300	4	
8		288296001	PLATE - BRIDGE SUPPORT	4	
9		288971001	PLATE - SUBWELD	1	
10		277923001	BRIDGE - GEARBOX CARRIAGE	4	
11		288482001	ROLLER - 2 3/4 CAM	4	
12		296258357	SHIELD SWITCH	5	
13		285690001	SWITCH - LIMIT NO/NC SIDE ROTARY/ PIGTAIL	5	
14		285691001	LEVER - LIMIT SWITCH STRAIGHT	5	
15		533016	SCREW-MCH - 10-24 X 1.75-GR2-CZ- ROUND-SLTD	20	
16		234426001	BOLT-ROLLER MOUNT @26184	4	
17		597001	ZERK-1/4" NF 90 DEG GREASE	4	
18		235717001	WASHER-3/4 FLAT HARDENED YELLOW ZINC	28	
19		397001	NUT-3/4-10 GR 8 SLTL	4	
20		283177001	SELECTOR SWITCH KIT-LOCAL LOCKOUT	1	
21		238887001	BOLT-1-8 X 3 HHCS GR8 ZY	12	
22		238892001	WASHER-1" HARDENED FLAT ZY	24	
23		388024	BOLT-1-UNCX2 1/2 GR.8 HEX	12	
24		235746001	BOLT-3/4-10X2 GR8 HEX ZNC PLTD	20	
25		288459001	WASHER - 7/8 FLAT HARD ZINC PLATED	60	
26		145645001	BOLT - 5/8 - 11 X 2 GR.8 PLATED	24	
27		235715001	WASHER-5/8 SAE HARD ZINC PLTD	24	
28		700IB751	DECAL - LOCKOUT	1	
29		7000A393	DECAL - DANGER	1	
		700IA393	DECAL - DANGER	1	International
30		235721001	BOLT-1/2-13X1 1/2 GR8 ZINC PLT	8	
31		485025	WASHER-1/2 FLAT-HARDENED-YZ	8	
32		235731001	NUT-1/2-13 GR8 ZINC PLTD	8	
33		296258436	SHIELD - SWITCH	1	
34		277857001	FLOATING CUSHION - SUB	1	Breakdown Fig. 12-33
35		296263308	SPIRAL WEDGELOCK KEYS	3	
36		296258304	SCREW - HCS .875 - 9 X2,GR8,YZ	60	

Frame-Rotation Gearbox/Carriage Assy Fig 2-9r01

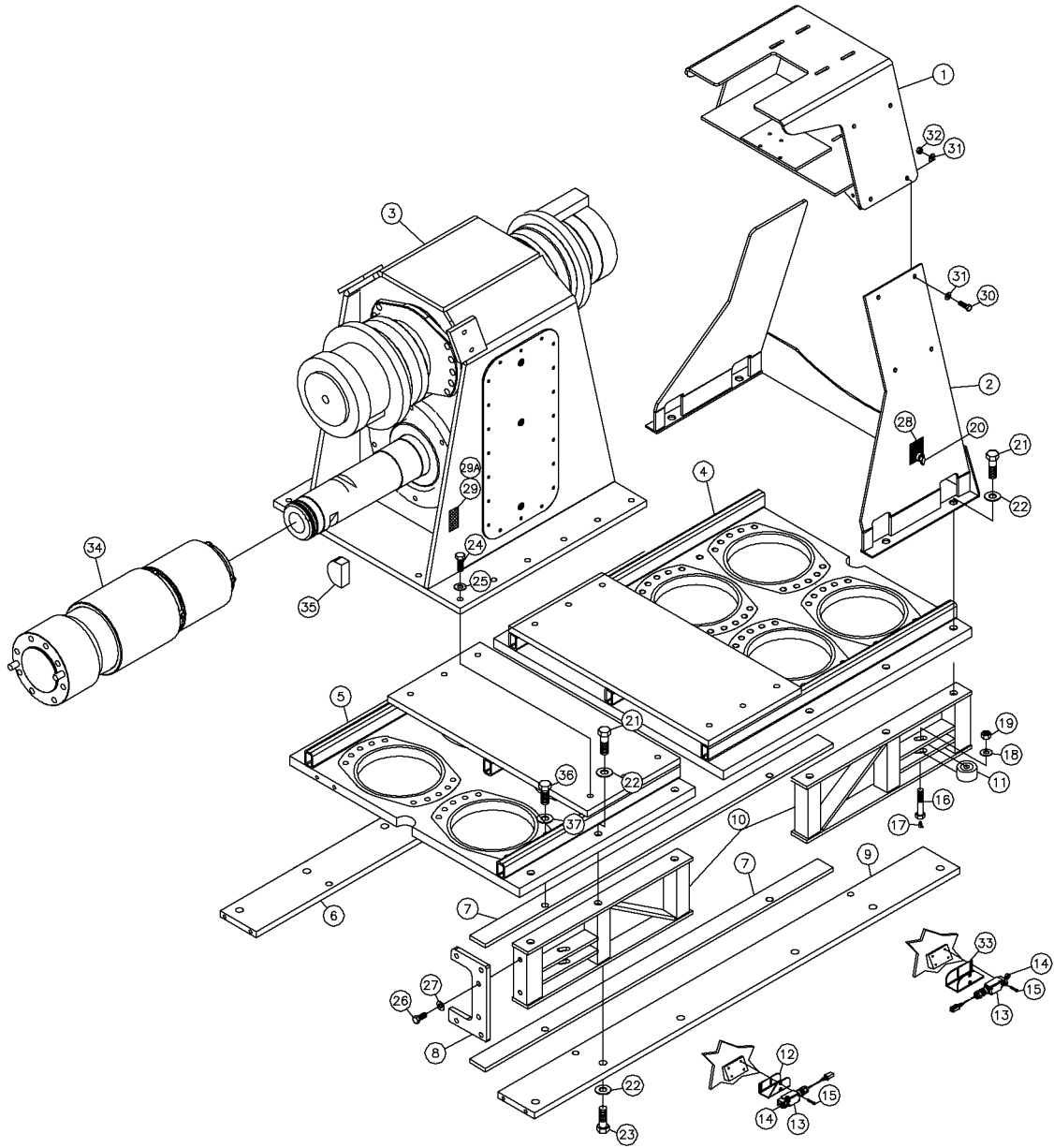

Frame-Rotation Gearbox/Carriage Assy Fig 2-9r01

REF. NO.	*	PART NO.	DESCRIPTION	QTY.	REMARKS
		Revision	June, 2002		Correct Title & Delete and Add parts
1		288443001	VALVE - MOUNT HOSE CARRIER	1	
2		288444001	HOUSING HOSE CARRIER	1	
3		288481001	GEAR BOX HEAD ASSEMBLY	1	Breakdown Fig 2-10
4		277925001	FRAME - GEARBOX CARRIAGE	1	
5		277934001	FRAME GEARBOX CARRIAGE	1	
6		288312001	BAR - BRIDGE SLIDE	1	
7		288311001	SLIDE - GEARBOX D150X300	4	
8		288296001	PLATE - BRIDGE SUPPORT	4	
9		288971001	PLATE - SUBWELD	1	
10		277923001	BRIDGE - GEARBOX CARRIAGE	4	
11		288482001	ROLLER - 2 3/4 CAM	4	
12		296258357	SHIELD SWITCH	5	
13		285690001	SWITCH - LIMIT NO/NC SIDE ROTARY/ PIGTAIL	5	
14		285691001	LEVER - LIMIT SWITCH STRAIGHT	5	
15		533016	BOLT-10-24 X1 3/4 RND HD STOVE	20	
16		234426001	BOLT-ROLLER MOUNT 54@20440	4	
17		597001	ZERK-1/4" NF 90 DEG GREASE	4	
18		235717001	WASHER-3/4 FLAT HARDENED YELLOW ZINC	8	
19		397001	NUT-3/4-10 GR 8 SLTL	4	
20	*	283177001	SELECTOR SWITCH KIT-LOCAL LOCKOUT	1	
21		238887001	BOLT-1-8 X 3 HHCS GR8 ZY	12	
22		238892001	WASHER-1" HARDENED FLAT ZY	24	
23		388024	BOLT-1-UNCX2 1/2 GR.8 HEX	12	
24		235746001	BOLT-3/4-10X2 GR8 HEX ZNC PLTD	20	
25		235717001	WASHER-3/4 FLAT HARDENED YELLOW ZINC	20	
26		145645001	BOLT - 5/8 - 11 X 2 GR.8 PLATED	24	
27		235715001	WASHER-5/8 SAE HARD ZINC PLTD	24	
28	*	700IB751	DECAL - LOCKOUT	1	
29		7000A393	DECAL - DANGER	1	
29A		700IA393	DECAL - DANGER	1	International
30		235721001	BOLT-1/2-13X1 1/2 GR8 ZINC PLT	8	
31		485025	WASHER-1/2 FLAT-HARDENED-ZINC	8	
32		235731001	NUT-1/2-13 GR8 ZINC PLTD	8	
33		296258436	SHIELD - SWITCH	1	
34		277857001	FLOATING CUSHION - SUB	1	Breakdown Fig 12-33
35		296263308	SPIRAL WEDGELOCK KEYS	3	
36		296258304	SCREW - HCS .875 - 9 X2,GR8,YZ	60	
37		288459001	WASHER - 7/8 FLAT HARD ZINC PLATED	60	

Frame-Rotation Gearbox/Carriage Assy Fig 2-9

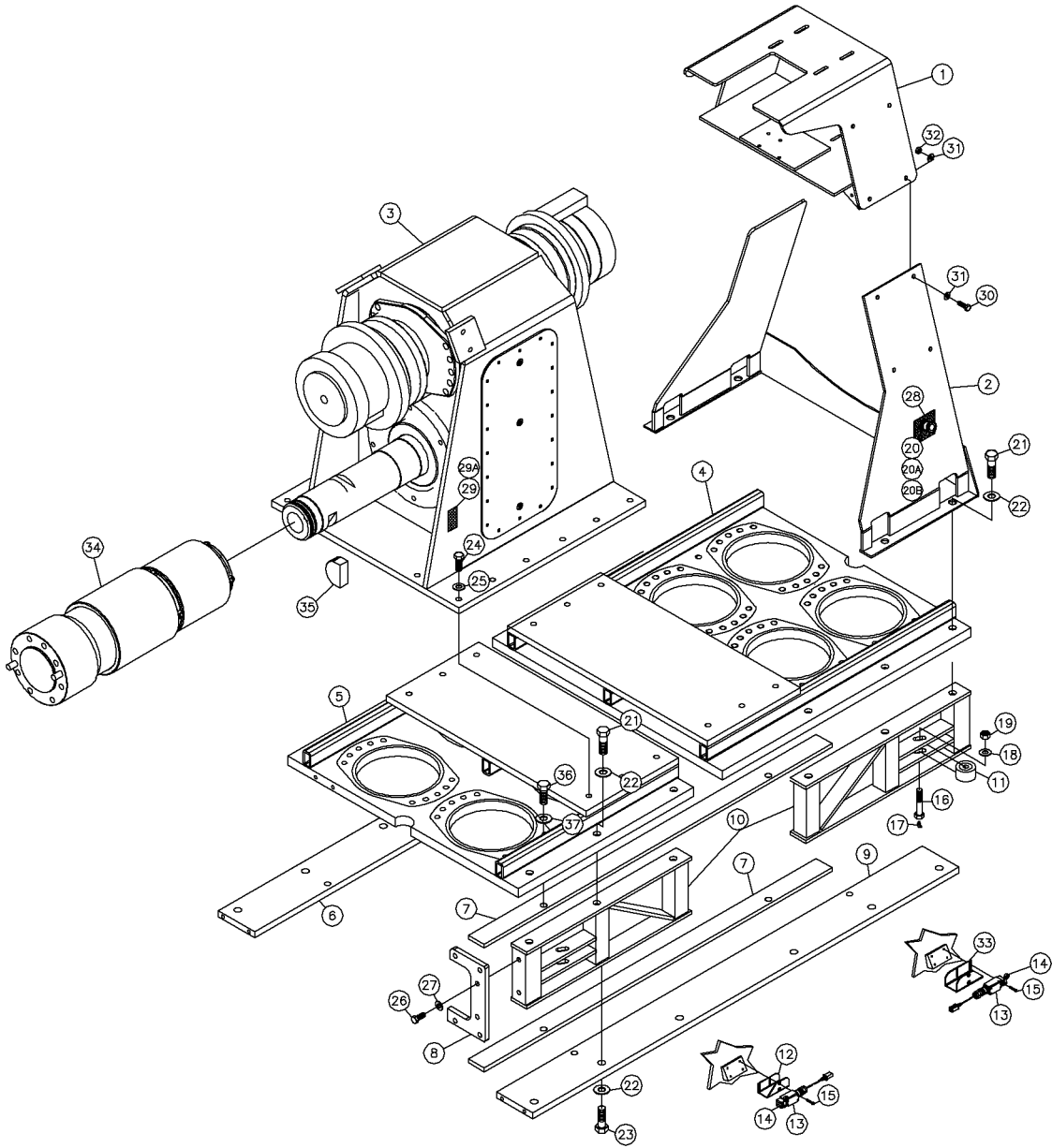

Frame-Rotation Gearbox/Carriage Assy Fig 2-9

REF. NO.	*	PART NO.	DESCRIPTION	QTY.	REMARKS
1		288443001	VALVE - MOUNT HOSE CARRIER	1	
2		288444001	HOUSING HOSE CARRIER	1	
3		288481001	GEAR BOX HEAD ASSEMBLY	1	Breakdown Fig 2-10
4		277925001	FRAME - GEARBOX CARRIAGE	1	
5		277934001	FRAME GEARBOX CARRIAGE	1	
6		288312001	BAR - BRIDGE SLIDE	1	
7		288311001	SLIDE - GEARBOX D150X300	4	
8		288296001	PLATE - BRIDGE SUPPORT	4	
9		288971001	PLATE - SUBWELD	1	
10		277923001	BRIDGE - GEARBOX CARRIAGE	4	
11		288482001	ROLLER - 2 3/4 CAM	4	
12		296258357	SHIELD SWITCH	5	
13		285690001	SWITCH - LIMIT NO/NC SIDE ROTARY/ PIGTAIL	5	
14		285691001	LEVER - LIMIT SWITCH STRAIGHT	5	
15		533016	BOLT-10-24 X1 3/4 RND HD STOVE	20	
16		234426001	BOLT-ROLLER MOUNT 54@20440	4	
17		597001	ZERK-1/4" NF 90 DEG GREASE	4	
18		235717001	WASHER-3/4 FLAT HARDENED YELLOW ZINC	8	
19		397001	NUT-3/4-10 GR 8 SLTL	4	
20		86575001	OPERATOR-PUSH/PULL W/O BUTTON	1	
20A		904563001	E-STOP LENS	1	
20B		215998001	BLOCK-N.C. CONTACT	1	
21		238887001	BOLT-1-8 X 3 HHCS GR8 ZY	12	
22		238892001	WASHER-1" HARDENED FLAT ZY	24	
23		388024	BOLT-1-UNCX2 1/2 GR.8 HEX	12	
24		235746001	BOLT-3/4-10X2 GR8 HEX ZNC PLTD	20	
25		235717001	WASHER-3/4 FLAT HARDENED YELLOW ZINC	20	
26		145645001	BOLT - 5/8 - 11 X 2 GR.8 PLATED	24	
27		235715001	WASHER-5/8 SAE HARD ZINC PLTD	24	
28		700IB656	DECAL - E-STOP DRILLING OPERATION	1	
29		7000A393	DECAL - DANGER	1	
29A		700IA393	DECAL - DANGER	1	International
30		235721001	BOLT-1/2-13X1 1/2 GR8 ZINC PLT	8	
31		485025	WASHER-1/2 FLAT-HARDENED-ZINC	8	
32		235731001	NUT-1/2-13 GR8 ZINC PLTD	8	
33		296258436	SHIELD - SWITCH	1	
34		277857001	FLOATING CUSHION - SUB	1	Breakdown Fig 12-33
35		296263308	SPIRAL WEDGELOCK KEYS	3	
36		296258304	SCREW - HCS .875 - 9 X2,GR8,YZ	60	
37		288459001	WASHER - 7/8 FLAT HARD ZINC PLATED	60	

Frame-Gearbox Components Assy Fig 2-10r01

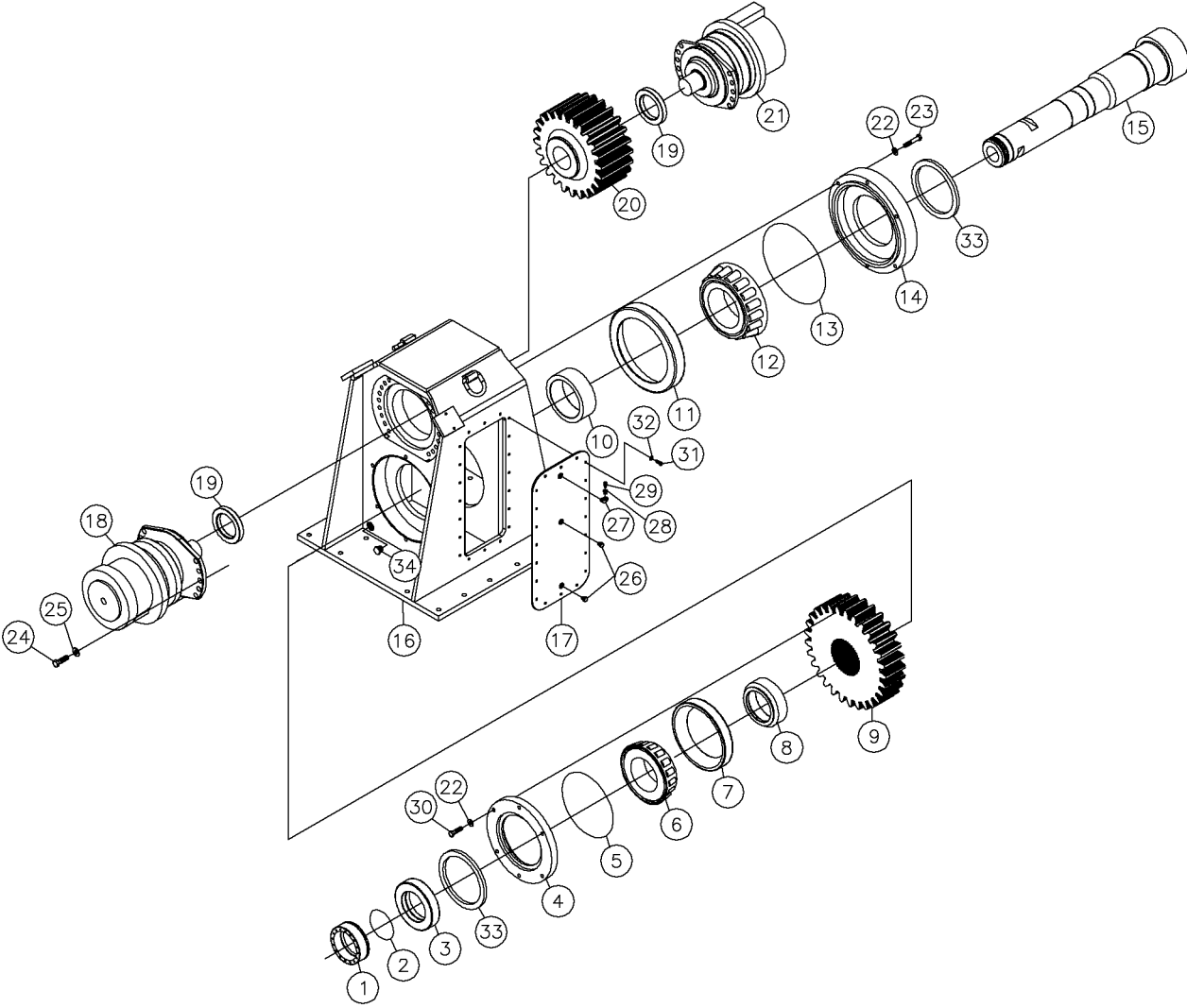

Frame-Gearbox Components Assy Fig 2-10r01

REF. NO.	*	PART NO.	DESCRIPTION	QTY.	REMARKS
		Revision Date	June, 2002		Update Figure
1		238178001	NUT-150X12-03 ADJUSTABLE LOCK	1	
2		228241001	O-RING #258 70D BUNA-N	1	
3		228192001	9.50 OD X 7.25 ID - 3.25	1	
4		228190001	17.00 OD X 9.50 ID - 2.25	1	
5		228242001	O-RING #279 70D BUNA-N	1	
6		1716171	BEARING CONE-6.125" #H936340	1	
7		1715111	CUP-BEARING #H936316	1	
8		228188001	9.00 OD X 5.75 ID - 3.00	1	
9		228170001	GEAR-29T 1.50DP 5" FACE	1	
10		228189001	9.5 OD X 7.25 ID - 3.25	1	
11		1715109	CUP-BEARING #351687	1	
12		1716169	BEARING CONE-7.50" #EE350750	1	
13		228243001	O-RING #282-70D BUNA-N	1	
14		228191001	19.75 OD X 9.50 ID - 3.25	1	
15		277856001	HEADSHAFT - ROTATION GEARBOX	1	
16		288496001	GEARBOX D150 X 300	1	
17		292907001	PANEL - GEARBOX ACCESS	1	
18		296258350	MOTOR - MS35 - 9 - G17 - P35 - 2A10 - 5000	1	Breakdown Fig12-37
19		288813001	SPACER - DRIVE GEAR	2	
20		277851001	GEAR - 24 TOOTH - POCLAIN MS-35	1	
21		277849001	MOTOR - MS35 - 9 - D17 - A35 - 2A10 - 5000	1	Breakdown Fig12-38
22		121820001	WASHER-5/8 HARDENED FLAT ZINC	12	
23		238208001	BOLT 5/8 - 11 X 3 1/2 GR 8 HEX ZYC	6	
24		142483024	BOLT-3/4-16X2 1/2 GR.8 ZINC	36	
25		235717001	WASHER-3/4 FLAT HARDENED YELLOW ZINC	36	
26		732007	1/2" PIPE PLUG BLACK STEEL	2	
27		716005	1/2"X90 DEG ST. EL.BLACK	1	
28		15031	FITTING-1/2 X 1/8 HEX BSHG	1	
29		599001	BREATHER VENT-1/8 NPT 131000	1	
30		238245001	BOLT 5/8" - 11 X 2 1/4 GR 8 HEX	6	
31		235727001	BOLT-3/8-16X1 GR8 HEX ZINC PLT	14	
32		244578001	WASHER-3/8" BOLT SEALING	14	
33		228205001	SEAL-9.5"SHAFTX11.5"ODX.625"	2	
34		613818001	PLUG - 12M ORING HEX MAGNETIC	1	

Frame-Gearbox Components Assy Fig 2-10

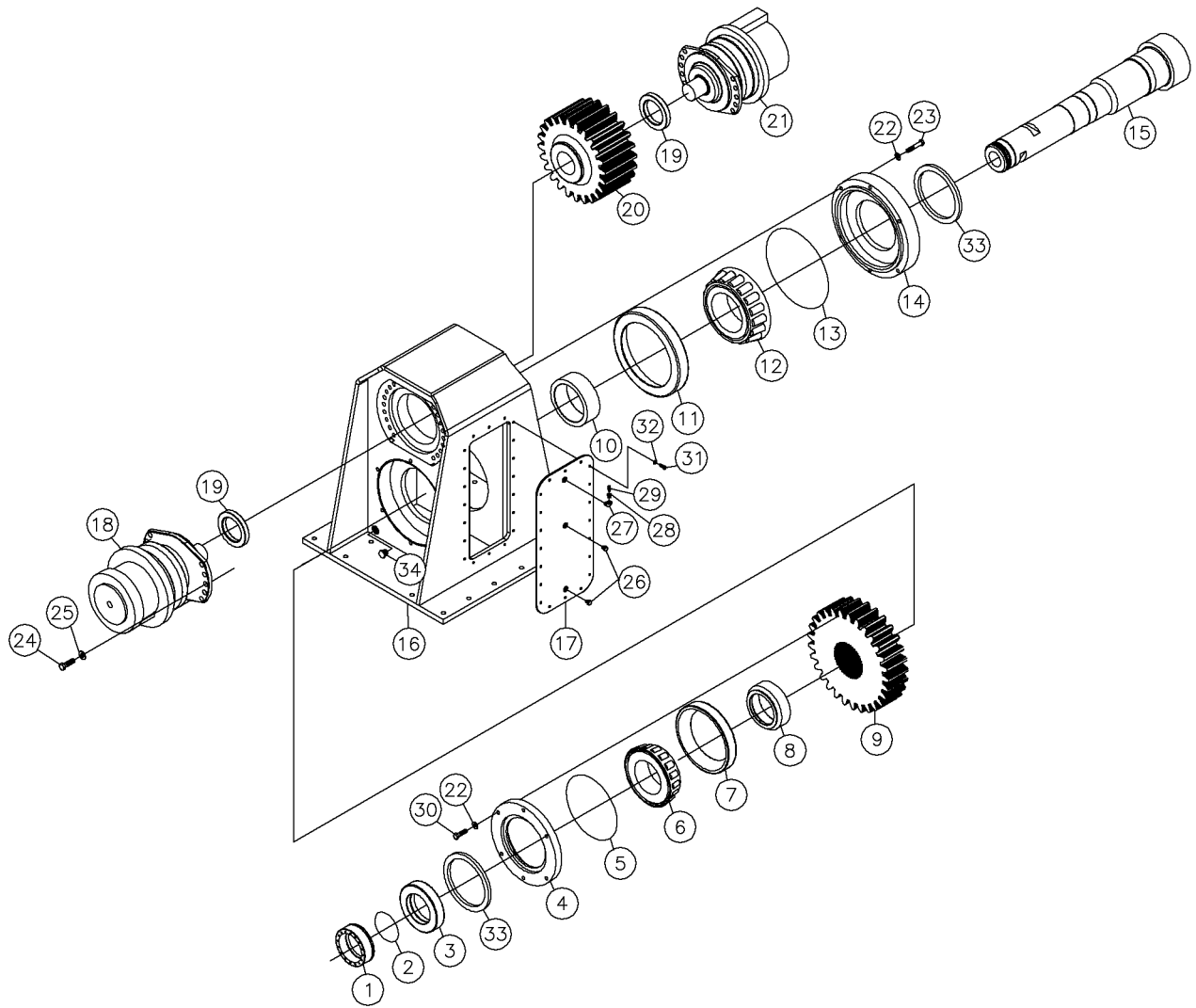

Frame-Gearbox Components Assy Fig 2-10

REF. NO.	*	PART NO.	DESCRIPTION	QTY.	REMARKS
1		238178001	NUT-150X12-03 ADJUSTABLE LOCK	1	
2		228241001	O-RING #258 70D BUNA-N	1	
3		228192001	9.50 OD X 7.25 ID - 3.25	1	
4		228190001	17.00 OD X 9.50 ID - 2.25	1	
5		228242001	O-RING #279 70D BUNA-N	1	
6		1716171	BEARING CONE-6.125" #H936340	1	
7		1715111	CUP-BEARING #H936316	1	
8		228188001	9.00 OD X 5.75 ID - 3.00	1	
9		228170001	GEAR-29T 1.50DP 5" FACE	1	
10		228189001	9.5 OD X 7.25 ID - 3.25	1	
11		1715109	CUP-BEARING #351687	1	
12		1716169	BEARING CONE-7.50" #EE350750	1	
13		228243001	O-RING #282-70D BUNA-N	1	
14		228191001	19.75 OD X 9.50 ID - 3.25	1	
15		277856001	HEADSHAFT - ROTATION GEARBOX	1	
16		288496001	GEARBOX D150 X 300	1	
17		292907001	PANEL - GEARBOX ACCESS	1	
18		296258350	MOTOR - MS35 - 9 - G17 - P35 - 2A10 - 5000	1	Breakdown Fig12-37
19		288813001	SPACER - DRIVE GEAR	2	
20		277851001	GEAR - 24 TOOTH - POCLAIN MS-35	1	
21		277849001	MOTOR - MS35 - 9 -D17 - A35 - 2A10 - 5000	1	Breakdown Fig12-38
22		121820001	WASHER-5/8 HARDENED FLAT ZINC	12	
23		238208001	BOLT 5/8 - 11 X 3 1/2 GR 8 HEX ZYC	6	
24		142483024	BOLT-3/4-16X2 1/2 GR.8 ZINC	36	
25		235717001	WASHER-3/4 FLAT HARDENED YELLOW ZINC	36	
26		732007	1/2" PIPE PLUG BLACK STEEL	2	
27		716005	1/2"X90 DEG ST. EL.BLACK	1	
28		15031	FITTING-1/2 X 1/8 HEX BSHG	1	
29		599001	BREATHER VENT-1/8 NPT 131000	1	
30		238245001	BOLT 5/8" - 11 X 2 1/4 GR 8 HEX	6	
31		235727001	BOLT-3/8-16X1 GR8 HEX ZINC PLT	14	
32		244578001	WASHER-3/8" BOLT SEALING	14	
33		228205001	SEAL-9.5"SHAFTX11.5"ODX.625"	2	
34		613818001	PLUG - 12M ORING HEX MAGNETIC	1	

Frame-Gearbox Rotation Sensor Assy Fig 2-11

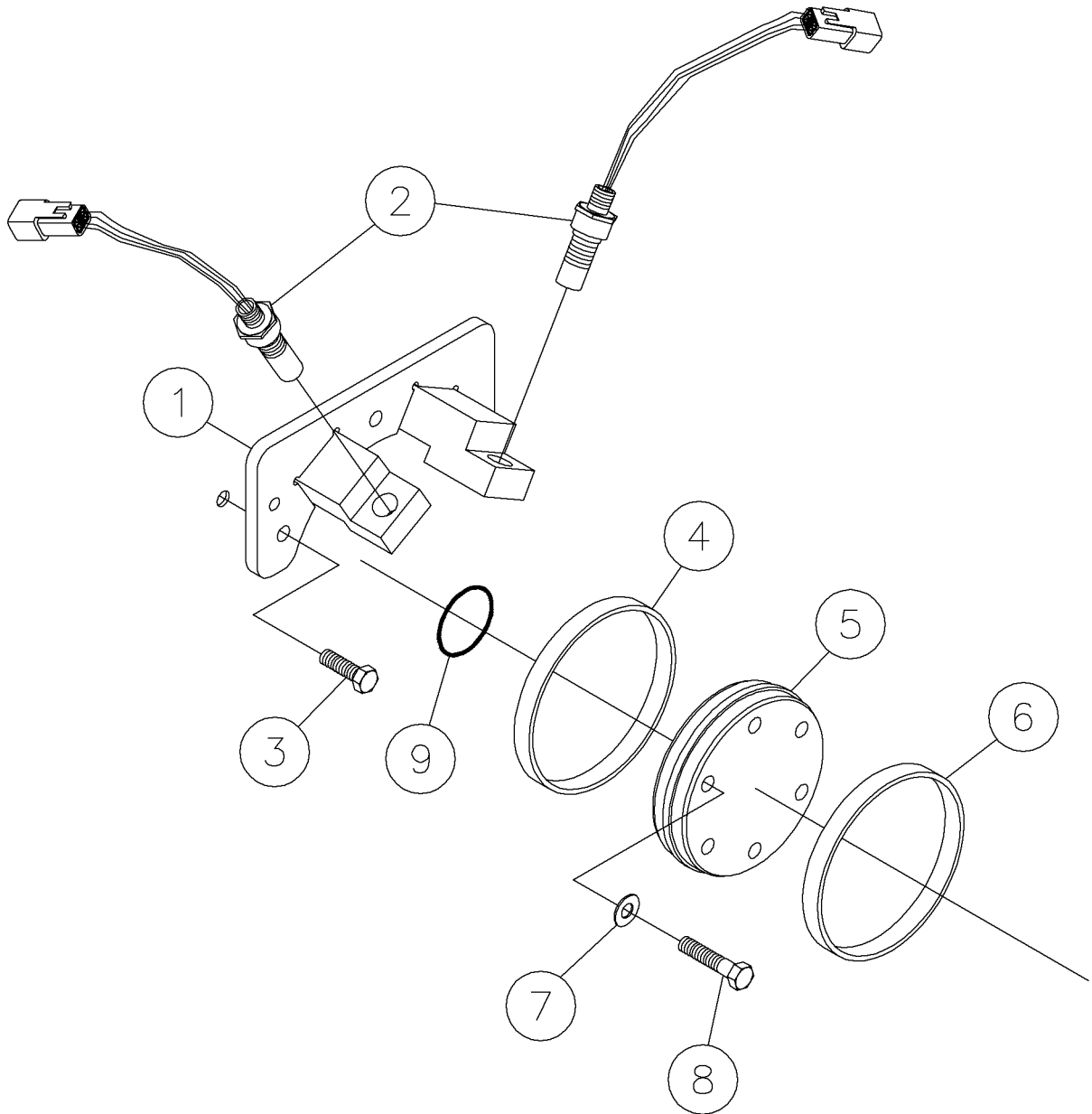

Frame-Gearbox Rotation Sensor Assy Fig 2-11

REF. NO.	*	PART NO.	DESCRIPTION	QTY.	REMARKS
1		292773001	PLATE - WIRELINE	1	
2		604451001	MAGNETIC PICKUP	2	
3		235736001	BOLT-3/8-16X1 1/4 ZINC PLTD	3	
4		234814001	PULSE RING- 60	1	
5		296256846	CAP - WIRELINE PLUG	1	
6		234815001	PULSE RING -2	1	
7		235713001	WASHER-3/8 SAE HARD ZINC PLTD	6	
8		235720001	BOLT-3/8-16X1 3/4 6R8 ZINC PLT	6	
9		200771001	O-RING #320	1	

Frame-Drive Chuck Assy Fig 2-12

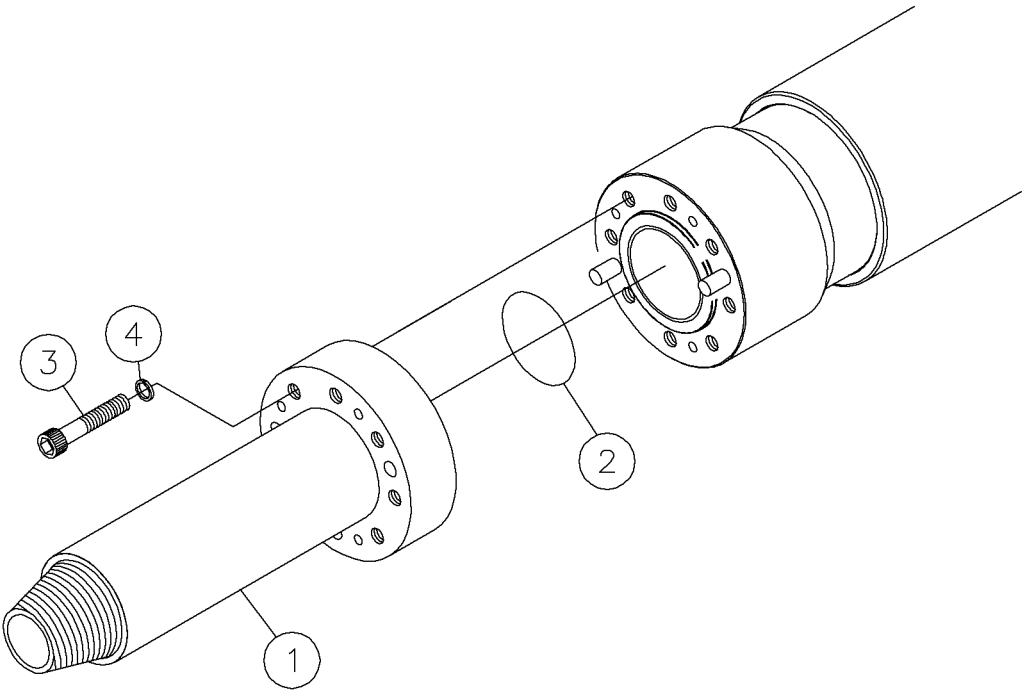

Frame-Drive Chuck Assy Fig 2-12

REF. NO.	*	PART NO.	DESCRIPTION	QTY.	REMARKS
1		296261572	DRIVE CHUCK - API 4 1/2" PIN	1	
2		296263322	O - RING - 70 D NITRILE	1	
3		296263325	SCREW - 7/8 - 14 X 4 UNF SOCKET HEAD	8	
4		296263326	WASHER 7/8 HIGHCOLLAR LOCK	8	

Frame-Battery Box Assy Fig 2-13r02

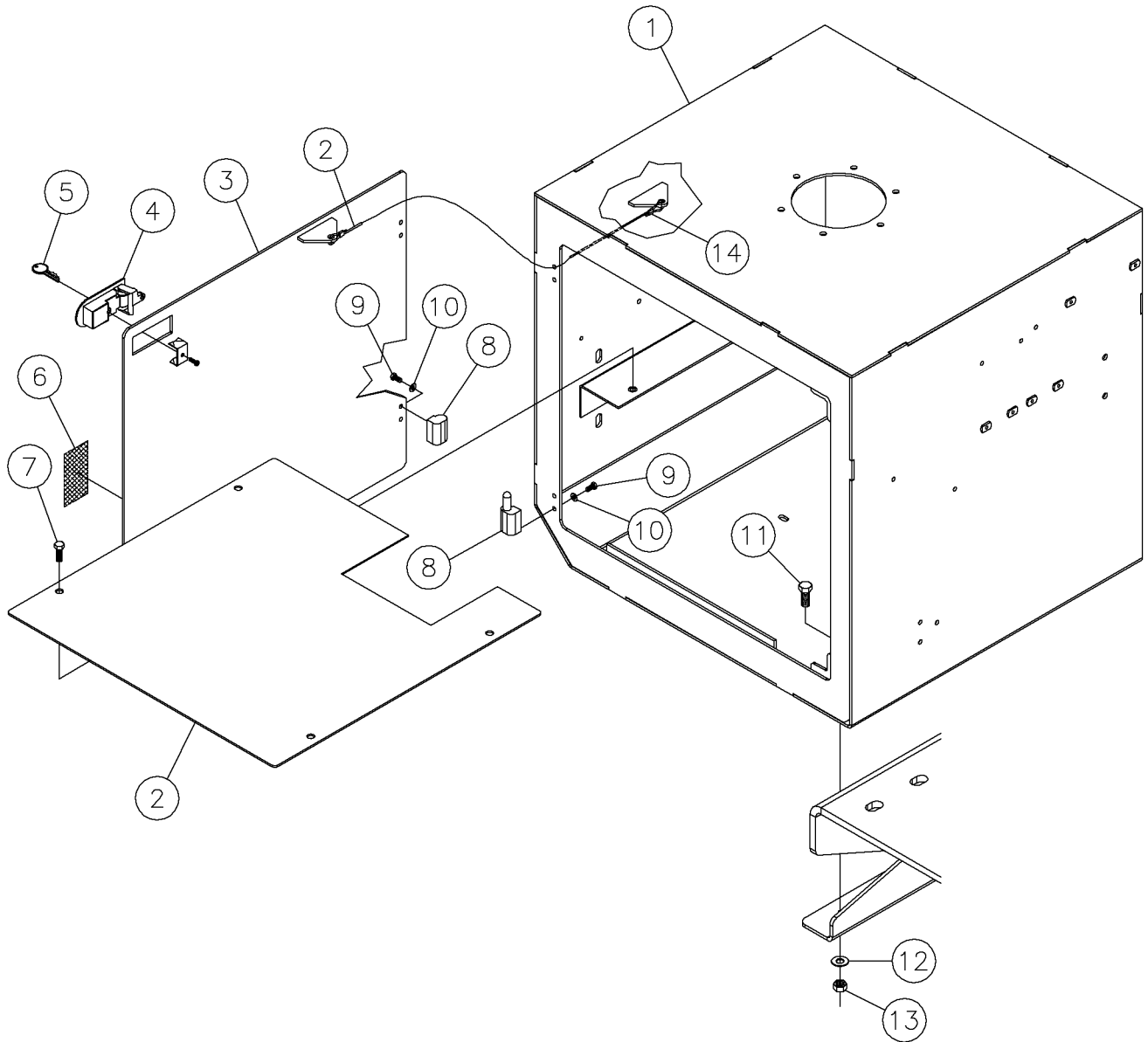

Frame-Battery Box Assy Fig 2-13r02

REF. NO.	*	PART NO.	DESCRIPTION	QTY.	REMARKS
		Revision Date	October, 2004		Update In Illustration & Parts List.
1		293683001	BOX - WELDMENT	1	
2		1838001	CONNECTOR-WIRE (ETC)	A/R	Specify Length
3		293682001	BOX - SUBWELD	1	
4		110479001	LATCH-SEALED LEVER	2	
5		97874003	KEYS	2	
6		70000044	DECAL-WARNING(AT/UND)	1	Domestic
		70001044	DECAL-WARNING	1	International
7		235726001	BOLT-3/8-16X3/4 GR8 HEX ZNCPLT	4	
8		224781001	HINGE-NYLON LIFT OFF 1/4" THD	1	Bottom Hinge
		224782001	HINGE-NYLON LIFT OFF 1/4" THD	1	Top Hinge (Not Shown)
9		235735001	BOLT-1/4-20X1 GR8 HEX ZNC PLTD	8	
10		235716001	WASHER - FLATSTRL - .25 - .28 X .63 - .06 - CZ	8	
11		235729001	SCREW-HCS-.50-13X1.00-GR8-YZ	4	
12		485025	WASHER-1/2 FLAT-HARDENED-YZ	4	
13		235731001	NUT-1/2-13 GR8 ZINC PLTD	4	
14		142423001	CRIMP-CABLE (FOR.068DIA.CABLE)	2	

Frame-Battery Box Assy Fig 2-13r01

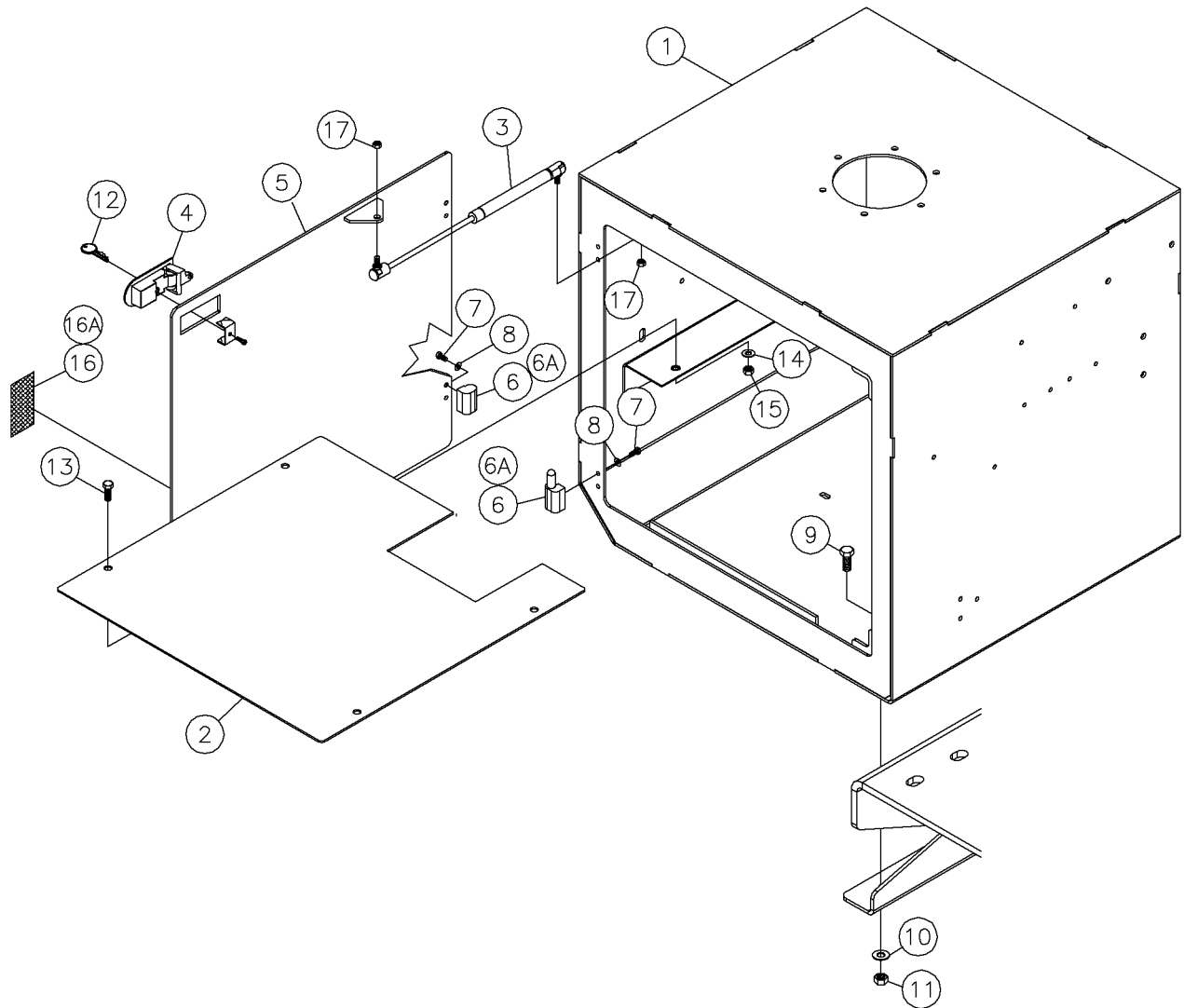

Frame-Battery Box Assy Fig 2-13r01

REF. NO.	*	PART NO.	DESCRIPTION	QTY.	REMARKS
		Revision Date	June, 2002		updated Drawing
1		293683001	BOX - WELDMENT	1	
2		292951001	COVER BATTERY	1	
3		149863001	SPRING - GAS 15.94 LENGTH X 6.30 STROKE 56.2 LBS	1	
4		110479001	LATCH-SEALED LEVER	2	
5		293682001	BOX - SUBWELD	1	
6		224781001	HINGE-NYLON LIFT OFF 1/4" THD	1	Bottom Hinge
6A		224782001	HINGE-NYLON LIFT OFF 1/4" THD	1	Top Hinge (Not Shown)
7		235735001	BOLT-1/4-20X1 GR8 HEX ZNC PLTD	8	
8		235716001	WASHER-1/4 SAE HARD ZINC PLTD	8	
9		235729001	SCREW-HCS-.50-13X1.00-GR8-YZ	4	
10		485025	WASHER-1/2 FLAT-HARDENED-ZINC	4	
11		235731001	NUT-1/2-13 GR8 ZINC PLTD	4	
12		97874003	KEYS	2	
13		235726001	BOLT-3/8-16X3/4 GR8 HEX ZNCPLT	4	
14		235713001	WASHER-3/8 SAE HARD ZINC PLTD	4	
15		235725001	NUT-3/8-16 GR8 ZINC PLTD	8	
16		70000044	DECAL-WARNING(AT/UND)	1	
16A		7000I044	DECAL-WARNING	1	International
17		235741001	NUT-5/16-18 GR8 ZINC PLTD	2	

Frame-Battery Box Assy Fig 2-13

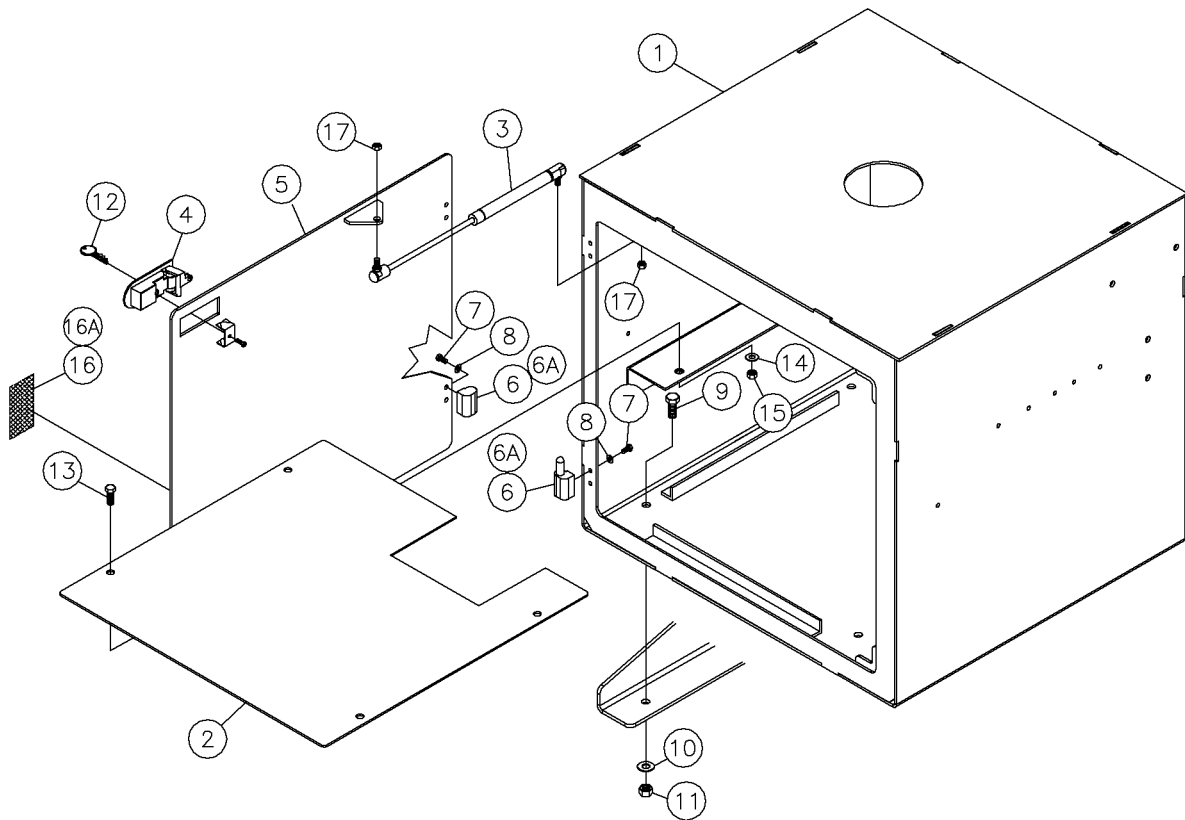

Frame-Battery Box Assy Fig 2-13

REF. NO.	*	PART NO.	DESCRIPTION	QTY.	REMARKS
1		293683001	BOX - WELDMENT	1	
2		292951001	COVER BATTERY	1	
3		149863001	SPRING - GAS 15.94 LENGTH X 6.30 STROKE 56.2 LBS	1	
4		110479001	LATCH-SEALED LEVER	2	
5		293682001	BOX - SUBWELD	1	
6		224781001	HINGE-NYLON LIFT OFF 1/4" THD	1	Bottom Hinge
6A		224782001	HINGE-NYLON LIFT OFF 1/4" THD	1	Top Hinge (Not Shown)
7		235735001	BOLT-1/4-20X1 GR8 HEX ZNC PLTD	8	
8		235716001	WASHER-1/4 SAE HARD ZINC PLTD	8	
9		235729001	SCREW-HCS-.50-13X1.00-GR8-YZ	4	
10		485025	WASHER-1/2 FLAT-HARDENED-ZINC	4	
11		235731001	NUT-1/2-13 GR8 ZINC PLTD	4	
12		97874003	KEYS	2	
13		235726001	BOLT-3/8-16X3/4 GR8 HEX ZNCPLT	4	
14		235713001	WASHER-3/8 SAE HARD ZINC PLTD	4	
15		235725001	NUT-3/8-16 GR8 ZINC PLTD	8	
16		70000044	DECAL-WARNING(AT/UND)	1	
16A		7000I044	DECAL-WARNING	1	International
17		235741001	NUT-5/16-18 GR8 ZINC PLTD	2	

Frame-Rod Cradle Assy Fig 2-14

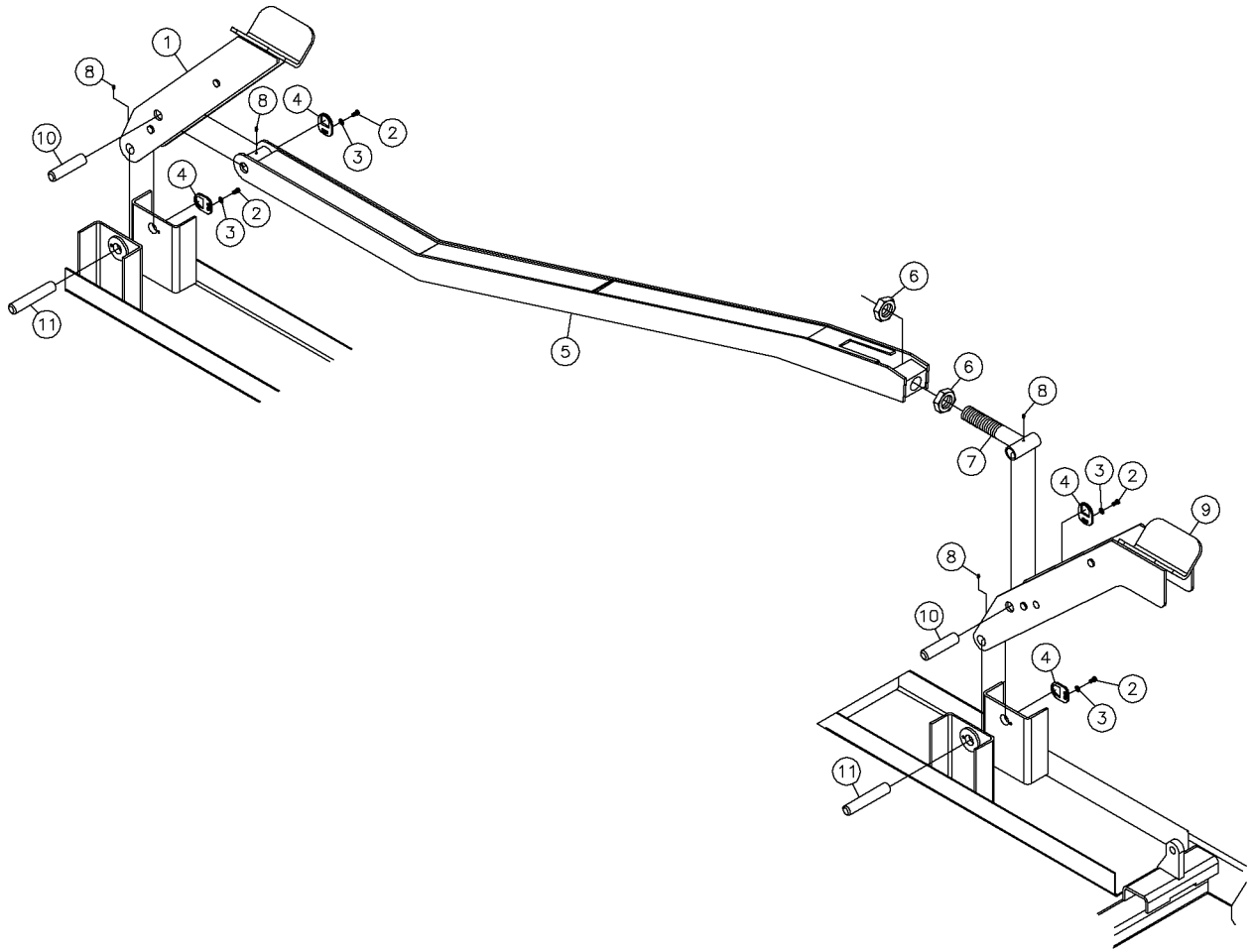

Frame-Rod Cradle Assy Fig 2-14

REF. NO.	*	PART NO.	DESCRIPTION	QTY.	REMARKS
1		288428001	CRADLE ARM	1	
2		235726001	BOLT-3/8-16X3/4 GR8 HEX ZNCPLT	4	
3		235713001	WASHER-3/8 SAE HARD ZINC PLTD	4	
4		277977001	PLATE - PIN RETAINER - 1.5"	4	
5		277954001	LINKAGE - ROD CRADLE	1	
6		275280001	NUT -2-4 ACME - 2G	2	
7		277974001	LINKAGE - CRADLE ADJUSTMENT	1	
8		595001	ZERK-1/4" NPT ST GREASE	4	
9		288427001	CRADLE - ARM	1	
10		277978001	LINKAGE PIN - 1.5 X 6	2	
11		277982001	PIVOT PIN - 1.5 X 7.75	2	

Frame-Deadman Assy Fig 2-15r02

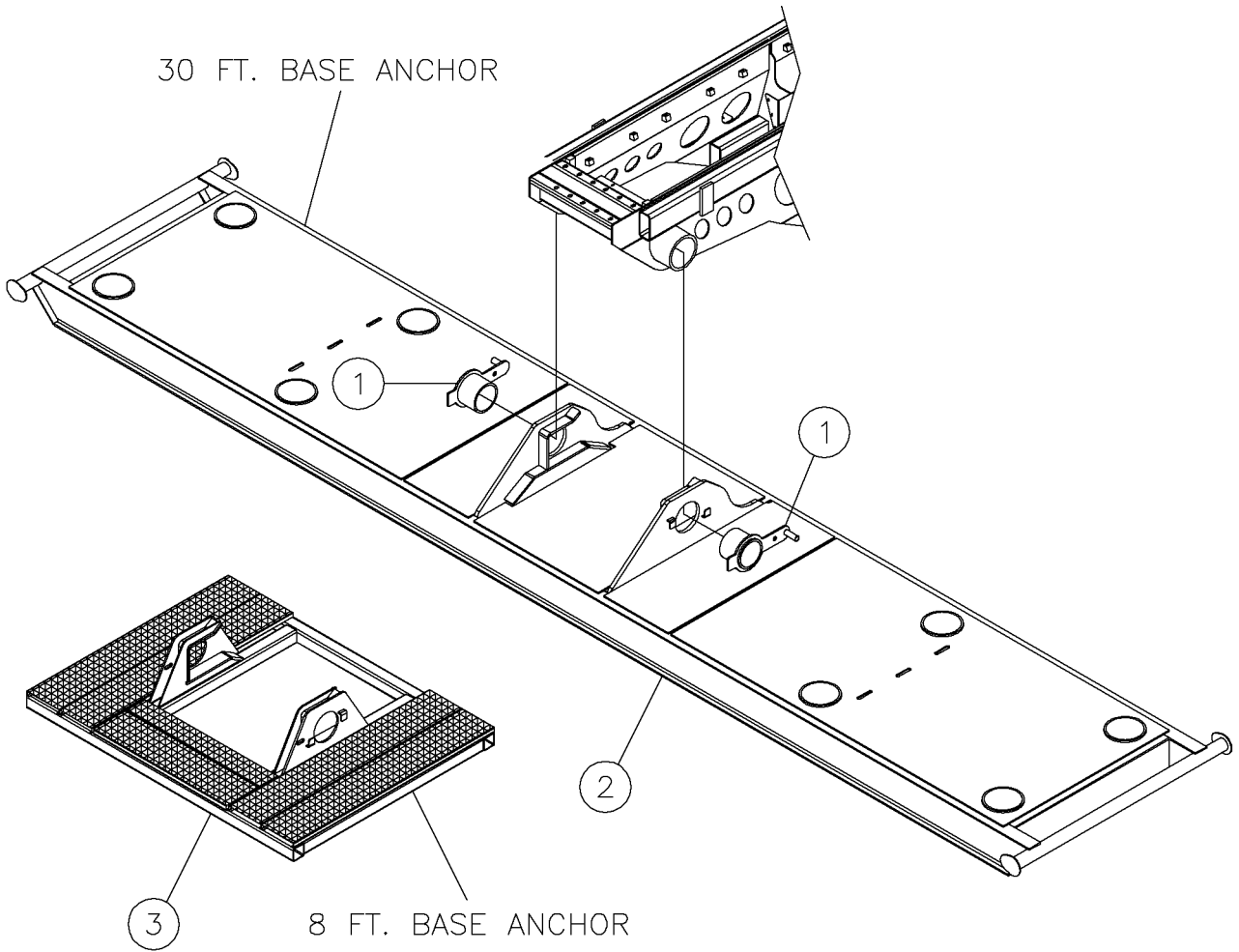

Frame-Deadman Assy Fig 2-15r02

REF. NO.	*	PART NO.	DESCRIPTION	QTY.	REMARKS
		Revision Date	October, 2004		Update In Illustration.
1		239434001	RACK BASE PIN	2	
2		296258483	DEADMAN D150X300	1	
3		239435001	BASE - RACK	1	

Frame-Deadman Assy Fig 2-15r01

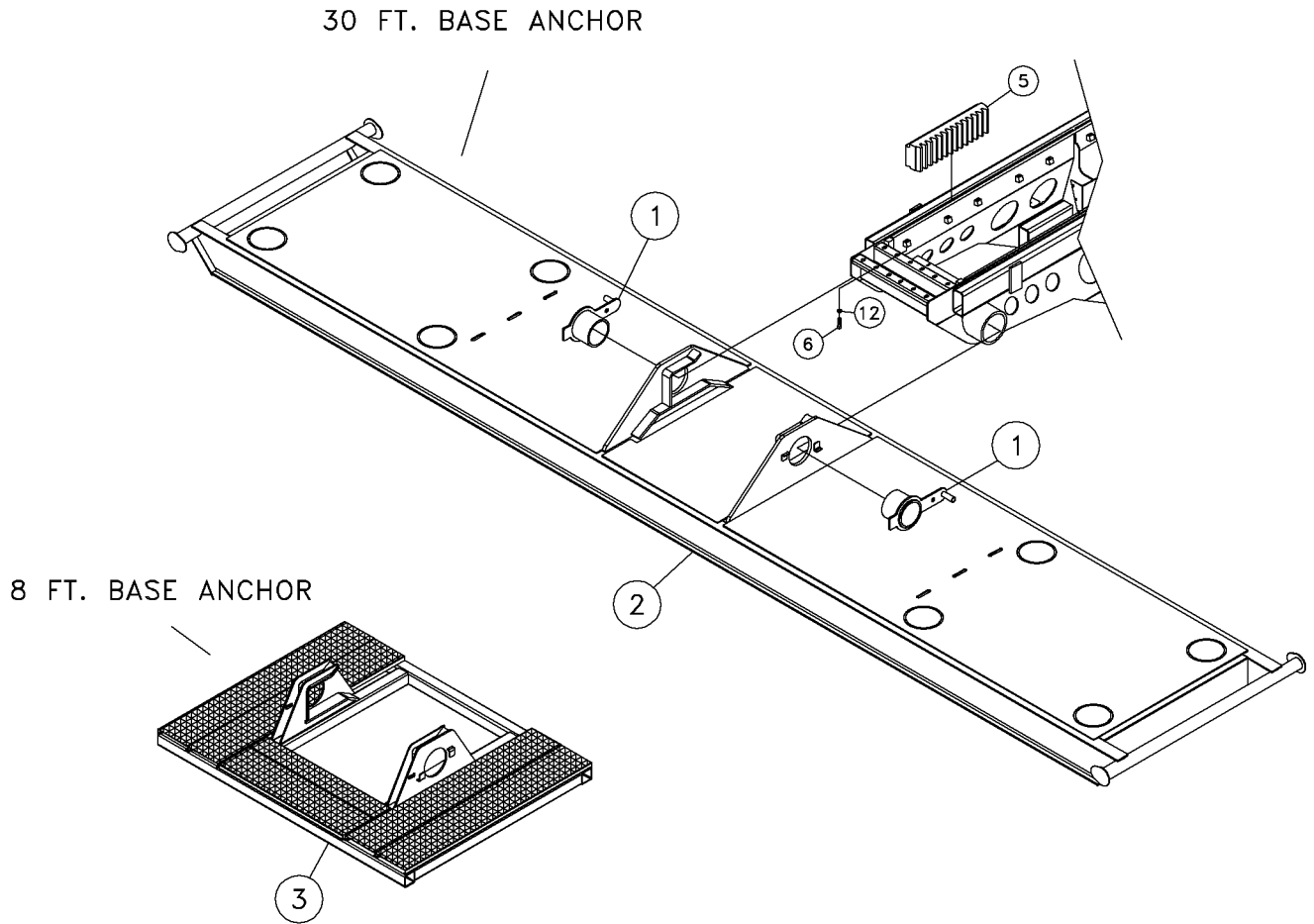

Frame-Deadman Assy Fig 2-15r01

REF. NO.	*	PART NO.	DESCRIPTION	QTY.	REMARKS
		Revision Date	June, 2002		Added Part
1		239434001	RACK BASE PIN	2	30 FT Anchor
2		296258483	DEADMAN D150X300	1	
3	*	239435001	BASE - RACK	1	8 FT Anchor

Frame-Deadman Assy Fig 2-15

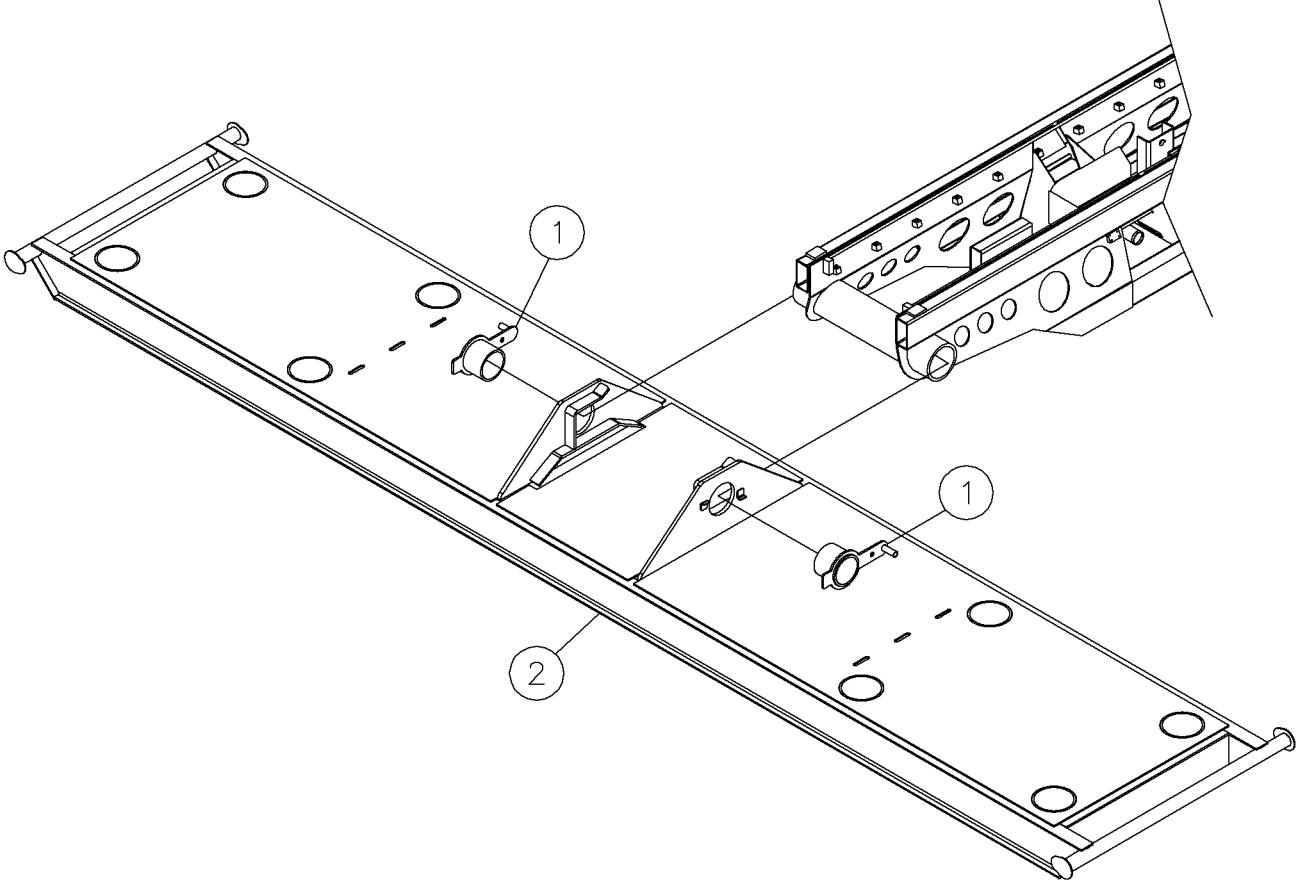

Frame-Deadman Assy Fig 2-15

REF. NO.	*	PART NO.	DESCRIPTION	QTY.	REMARKS
1		239434001	RACK BASE PIN	2	
2		296258483	DEADMAN D150X300	1	

Frame-Wireline Assy Fig 2-16

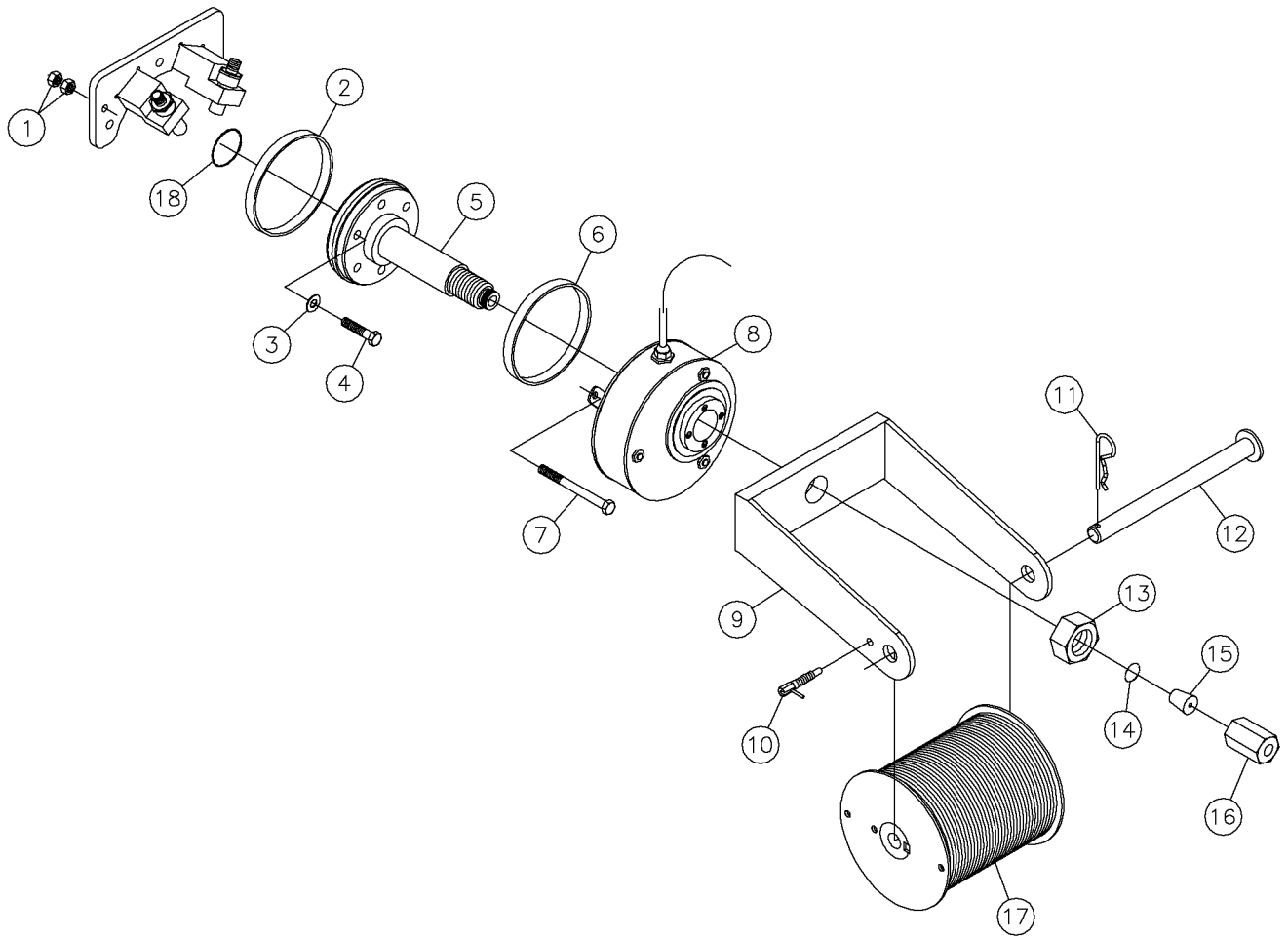

Frame-Wireline Assy Fig 2-16

REF. NO.	*	PART NO.	DESCRIPTION	QTY.	REMARKS
1		250576001	NUT-3/8 NC HEX JAM W/Y-ZINC	1	
2		234814001	60 PULSE RING	1	
3		235713001	WASHER-3/8 SAE HARD ZINC PLTD	6	
4		235720001	BOLT-3/8-16X1 3/4 6R8 ZINC PLT	6	
5		288476001	SHAFT - WIRELINE	1	
6		234815001	2 PULSE RING	1	
7		250541001	BOLT-3/8-16 X 4" GR8 HEX Y/ZI	1	
8		288272001	SLIP RING - 2 POLE 1.50" I.D.	1	
9		288474001	MOUNT - REEL	1	
10		250021001	PLUNGER-HAND RETRACTABLE	1	
11		20667001	HAIR PIN COTTER - .177 WIRE	1	
12		296256842	PIN - WIRELINE WELDMENT	1	
13		442001	NUT-1 1/4-7 HEX JAM	1	
14		792029	O-RING	1	
15		234957001	STOPPER- COMP.FITTING 12GA	1	
16		234888001	COVER-COMPRESSION FITTING	1	
17		240529001	WIRE-10 GA. RED 500' (THHN)	1	
18		200771001	O-RING #320	1	

Frame-Ladder Assy Fig 2-17

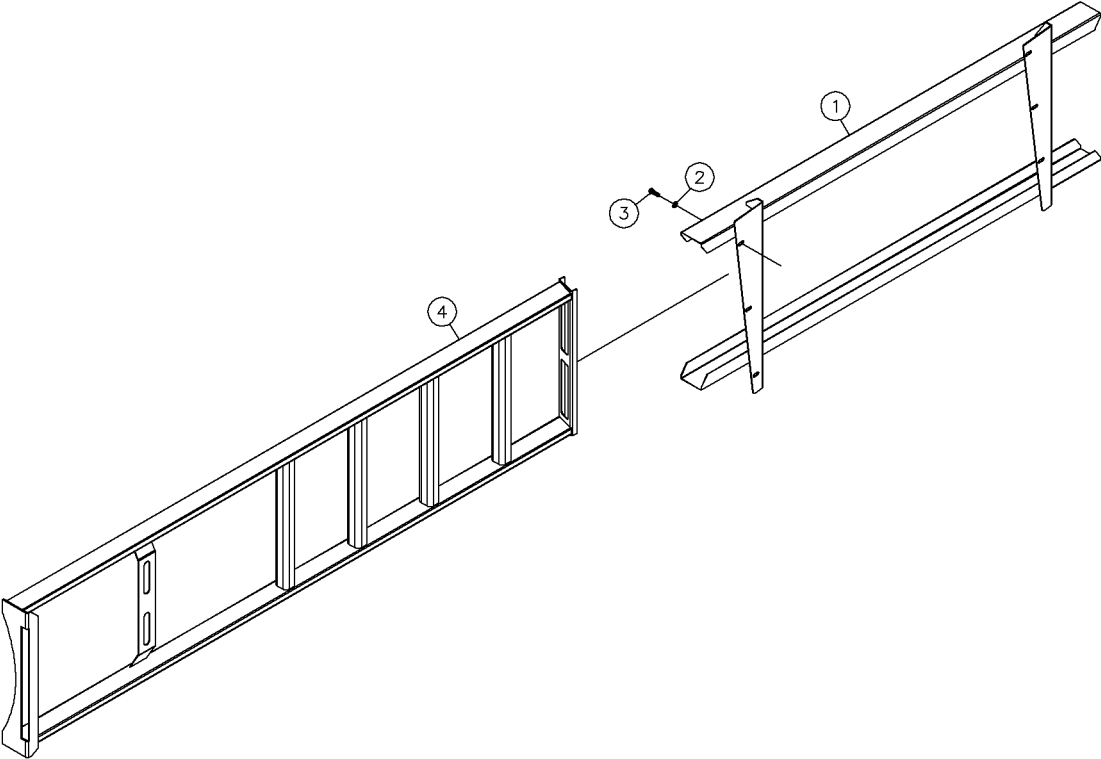

Frame-Ladder Assy Fig 2-17

REF. NO.	*	PART NO.	DESCRIPTION	QTY.	REMARKS
1		296262510	RACK - LADDER	1	
2		235713001	WASHER-3/8 SAE HARD ZINC PLTD	6	
3		235736001	BOLT-3/8-16X1 1/4 ZINC PLTD	6	
4		296262505	LADDER - FLUID FILL ACCESS	1	

Frame- Rack Position PPU Assy Fig 2-18r01

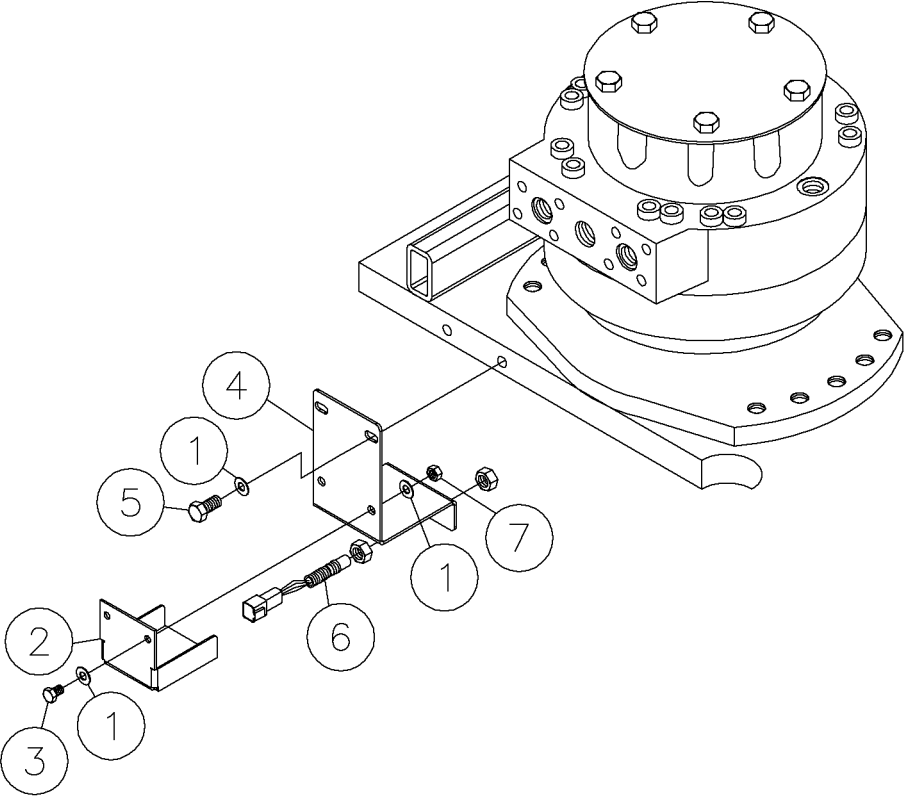

Frame- Rack Position PPU Assy Fig 2-18r01

REF. NO.	*	PART NO.	DESCRIPTION	QTY.	REMARKS
		Revision	June, 2002		Change Title And Remove Item From Illustration
1		235713001	WASHER-3/8 SAE HARD ZINC PLTD	6	
2		296258432	COVER - PPU SWITCH	1	
3		240310001	BOLT-3/8-16X1/2 GR8 ZINC PLTD	2	
4		292758001	MOUNT - PPU	1	
5		235727001	BOLT-3/8-16X1 GR8 HEX ZINC PLT	2	
6		604451001	MAGNETIC PICKUP	1	
7	*	235725001	NUT-3/8-16 GR8 ZINC PLTD	2	

Frame-Rotation PPU Assy Fig 2-18

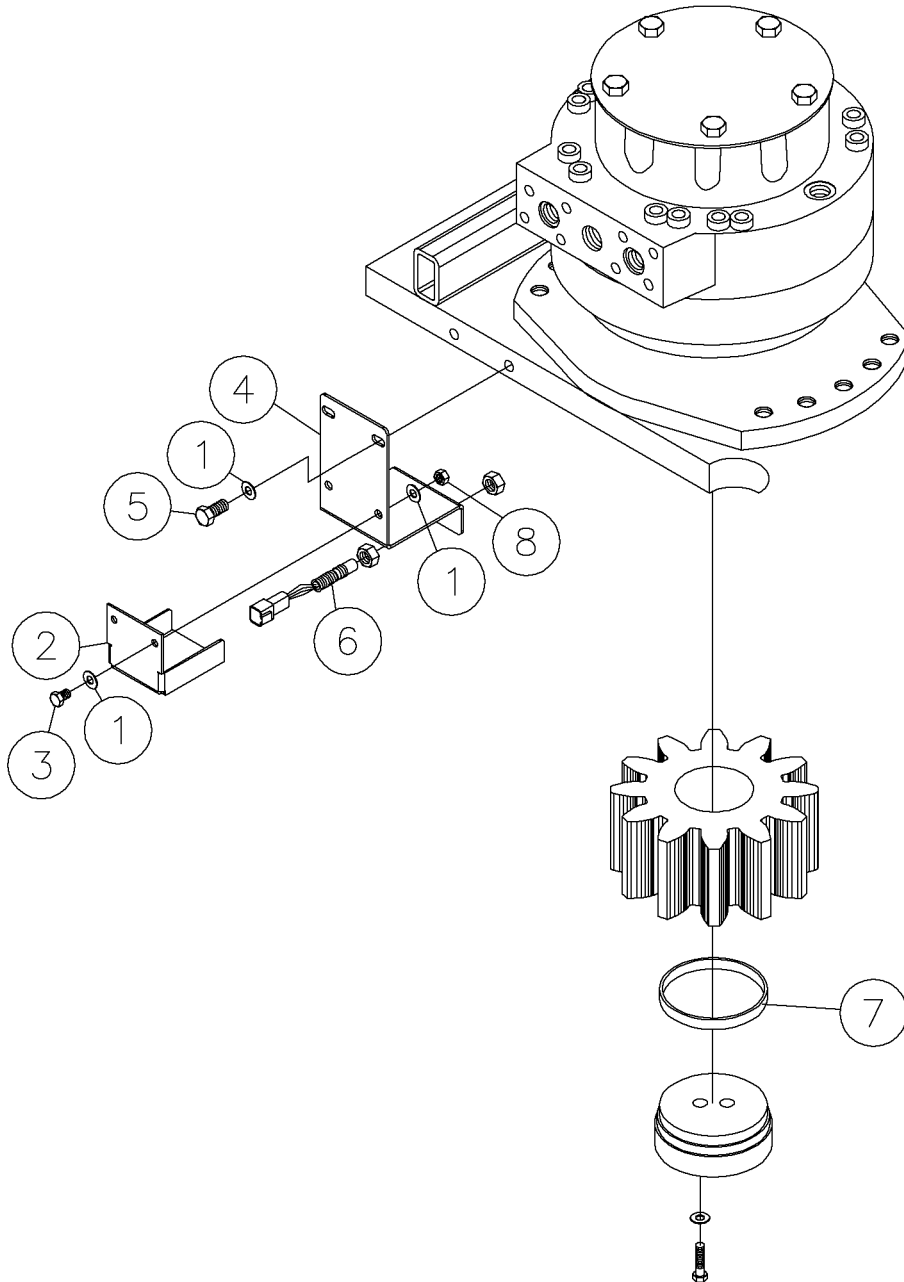

Frame-Rotation PPU Assy Fig 2-18

REF. NO.	*	PART NO.	DESCRIPTION	QTY.	REMARKS
1		235713001	WASHER-3/8 SAE HARD ZINC PLTD	6	
2		296258432	COVER - PPU SWITCH	1	
3		240310001	BOLT-3/8-16X1/2 GR8 ZINC PLTD	2	
4		292758001	MOUNT - PPU	1	
5		235727001	BOLT-3/8-16X1 GR8 HEX ZINC PLT	2	
6		604451001	MAGNETIC PICKUP	1	
7		234814001	60 PULSE RING	1	
8		235725001	NUT-3/8-16 GR8 ZINC PLTD	2	

Engine Components Fig 3-1

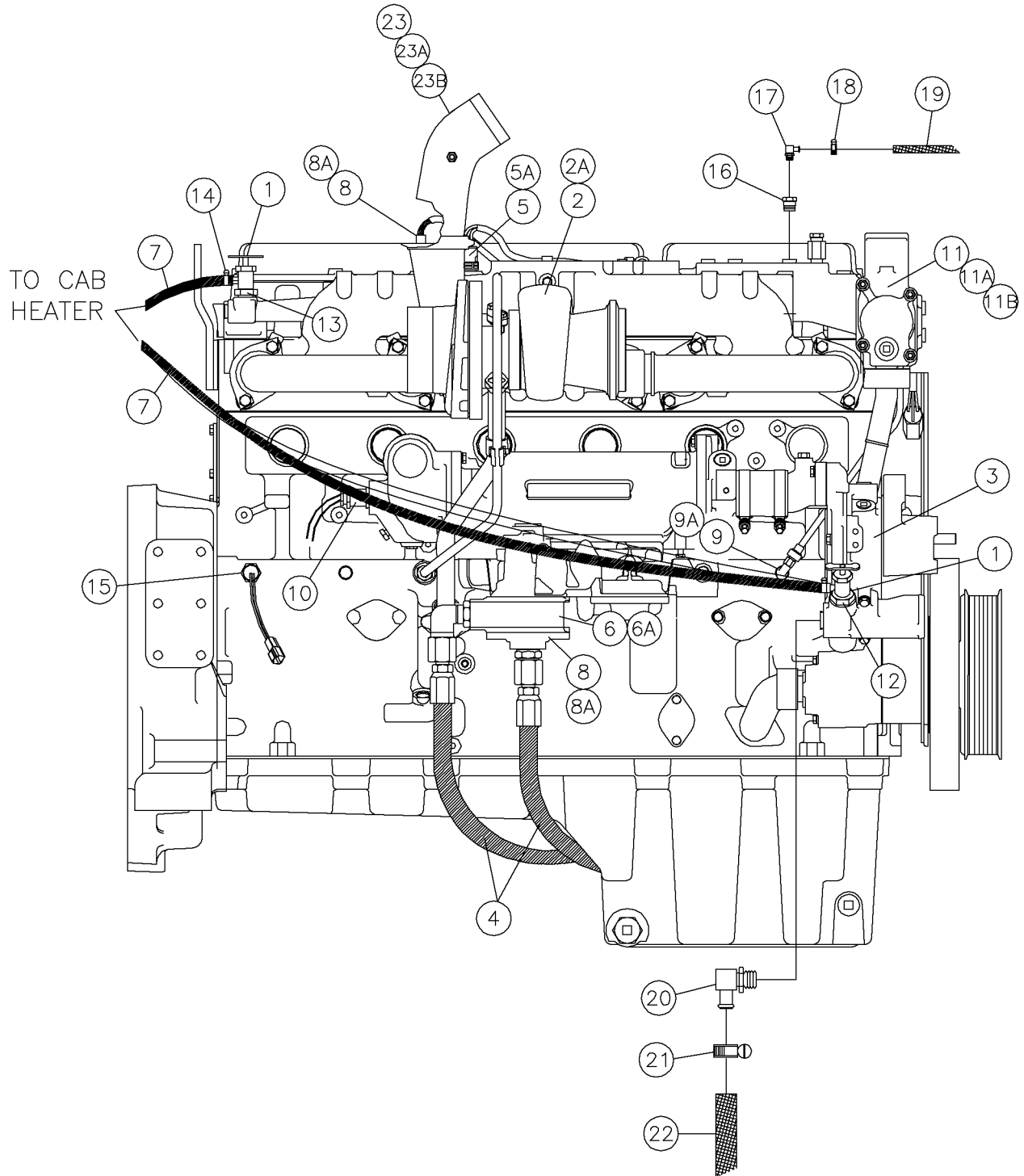

Engine Components Fig 3-1

REF. NO.	*	PART NO.	DESCRIPTION	QTY.	REMARKS
1		82633001	FITTING-HEATER SHUT-OFF	2	
2		296261888	TURBO	1	
2A		296261889	TURBO GASKET	1	
3		296261890	WATER PUMP	1	
4		296261891	HOSE - REMOTE OIL	2	
5		296261892	SENSOR	1	
5A		296261893	O - RING	1	
6		296261894	ADAPTER	1	
6A		296261895	O - RING	1	
7		296256499	HOSE - HEAT - .63X360	2	
8		296261896	BASE	1	
8A		296261897	O - RING	1	
9		296261898	SENSOR - OIL PRESSURE	1	
9A		296261899	O - RING	1	
10		296261900	WATER HEATER	1	
11		296261901	THERMOSTAT	1	
11A		296261902	GASKET - THERMOSTAT	1	
11B		296261903	SEAL	1	
12		730009	FITTING-3/4"X 3/8" HEX BUSHING STEEL	1	
13		730005	FITTING-1/2X3/8HEX BUSH. STEEL	1	
14		1580003	HOSE CLAMP - 3/4"	4	
15		283151001	ENGINE OIL PRESSURE SWITCH	1	
16		296256638	REDUCER - 1/2 NPTX 1/8 NPT HEX	1	
17		83124001	FITTING- #1556 WTHR-HD	1	
18		1580001	HOSE CLAMP - 3/8"	1	
19		620001	HOSE - 5/16 FUEL LINE	A/R	P/N Qty Of 1 = 1 Foot
20		901888001	FITTING-1 X 3/4 90 INSERT	1	
21		1580007	HOSE CLAMP - 1 1/2"	1	
22		296262503	TUBE - INTAKE EXTENSION	1	
23		296264778	ELBOW	1	
23A		296264777	O-RING	1	
23B		296264776	CLAMP	1	

Engine Components Fig 3-2r01

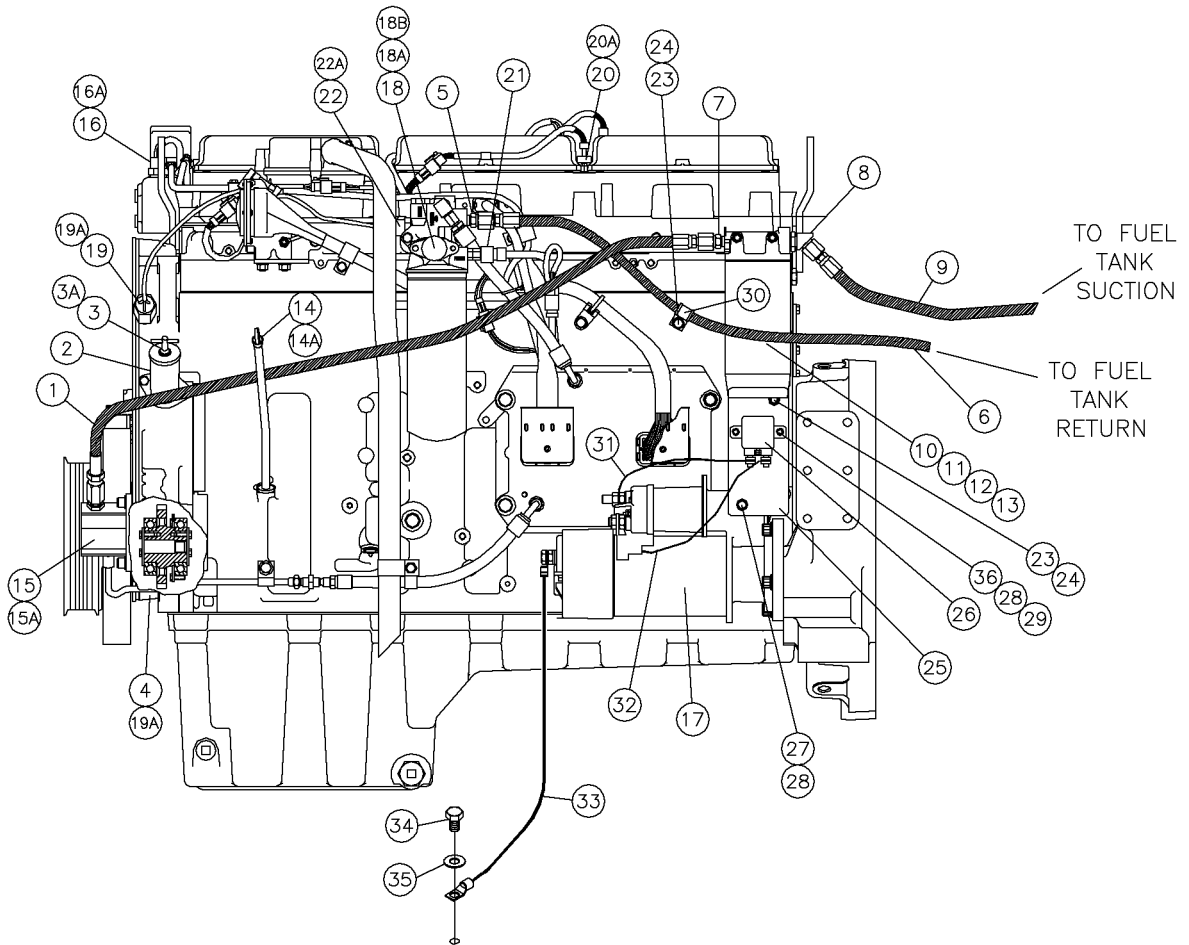

Engine Components Fig 3-2r01

REF. NO.	*	PART NO.	DESCRIPTION	QTY.	REMARKS
		Revision Date	June, 2002		Update In Parts List.
1		296258477	HOSE - FUEL 10 X 53 10FS JIC ST/ST 500 PSI	1	
2		296258443	TUBE - OIL FILL(MACHINED)	1	
3		296261905	FILLER CAP	1	
3A		296261906	RUBBER SEAL	1	
4		296261918	SENSOR	1	
5		101509001	COUPLING-10F JIC DIAGNOSTIC	1	
6		296258478	HOSE - FUEL - 10 X132 10FS JIC ST/ST 500 PSI	1	
7		53827001	FITT.-#10M O-RING-#10M JIC ST.	1	
8		56725001	FITTING-10MX10M JIC 45 DEG.	1	
9		296258479	HOSE - FUEL - 10 X 74 10FS JIC ST/ST 500 PSI	1	
10		111498001	FILTER-FUEL (COMPLETE)	1	
11		111498003	ELEMENT - FUEL FILTER	1	
12		111498005	BOWL ASSEMBLY FUEL FILTER	1	
13		111498007	HEAD - FUEL FILTER	1	
14		296261904	DIPSTICK	1	
14A		296261909	DIPSTICK TUBE	1	
15		296261910	PUMP - FUEL	1	
15A		296261911	GASKET	1	
16		296261892	SENSOR	1	
16A		296261913	O - RING	1	
17		601907001	STARTER ASSEMBLY	1	
18		296261914	FUEL PRIMING PUMP	1	
18A		121490001	GASKET-FUEL PRIMING	1	
18B		154657001	FILTER - FUEL 2 MICRON	1	
19		296261907	SENSOR	1	
19A		296261908	O - RING	2	
20		296261919	SENSOR - ATMOSPHERIC PRESSURE	1	
20A		296261920	O - RING	1	
21		296261898	SENSOR - OIL PRESSURE	1	
22		296261892	SENSOR	1	
22A		296261893	O - RING	1	
23		508476020	SCREW-HCS,M10- 1.50X20,10.9,YZ,ISO4017,FT	2	

Engine Components (Continued) Fig 3-2r01

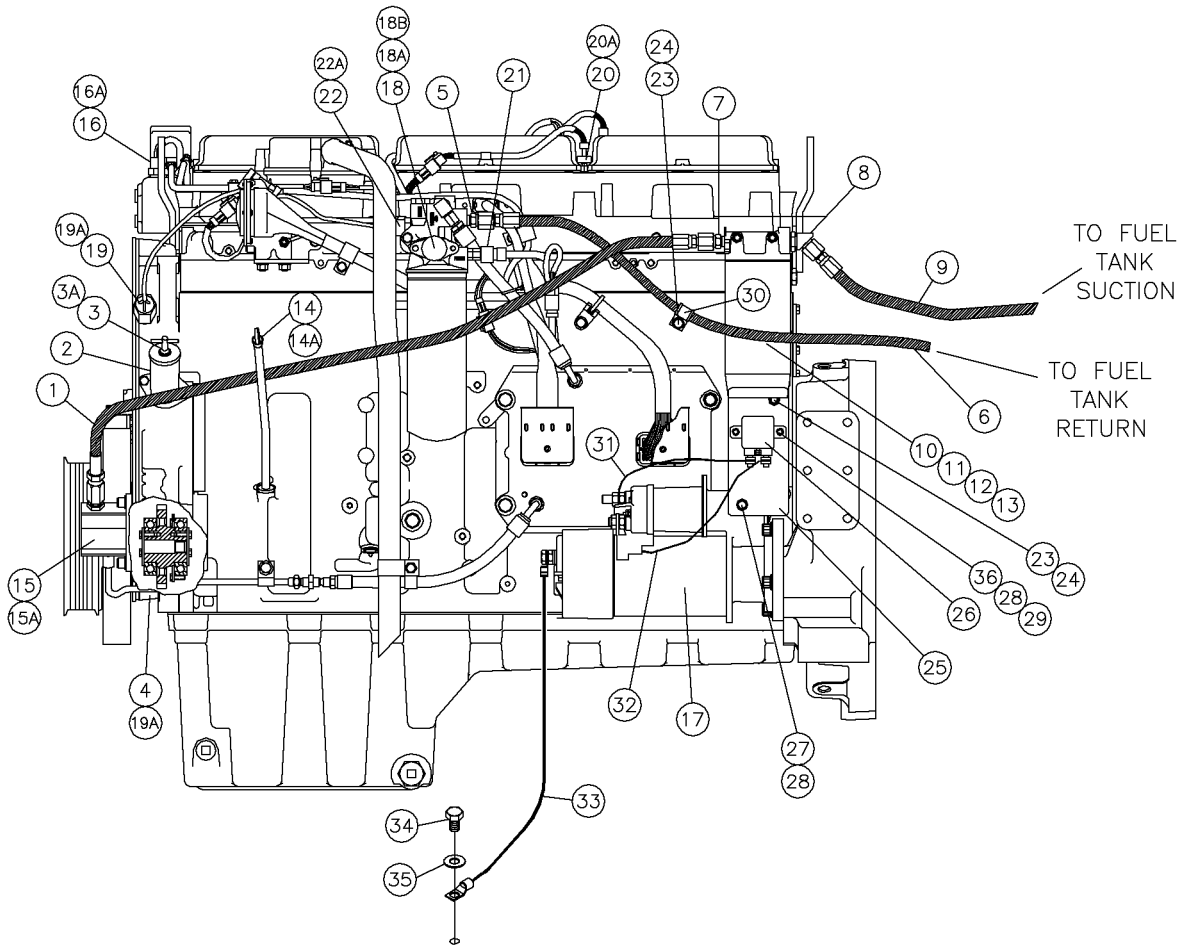

Engine Components (Continued) Fig 3-2r01

REF. NO.	*	PART NO.	DESCRIPTION	QTY.	REMARKS
		Revision Date	June, 2002		Update In Parts List.
24		235713001	WASHER-3/8 SAE HARD ZINC PLTD	2	
25		283108001	MOUNTING BRACKET START RELAY	1	
26		283033001	START RELAY	1	
27		508475020	SCREW-HCS,M8-1,25X20,10.9,YZ,ISO4017,FT.	1	
28		235714001	WASHER-5/16 SAE HARD ZINC PLTD	3	
29		235741001	NUT-5/16-18 GR8 ZINC PLTD	2	
30		2595013	CLAMP-1"HOSE W/VINYL COAT	3	
31		283139001	WIRING HARNESS-START RELAY POWER	1	
32	*	283201001	WIRING HARNESS-STARTING MOTOR CONTROL	1	
33		283135001	CABLE-CHASIS GROUND	1	
34		235728001	BOLT-1/2-13X3/4 GR8 ZINC PLTD	1	
35		485025	WASHER-1/2 FLAT-HARDENED-ZINC	1	
36		235742001	BOLT-5/16-18X3/4 GR8 ZINC PLTD	2	

Engine Components Fig 3-2

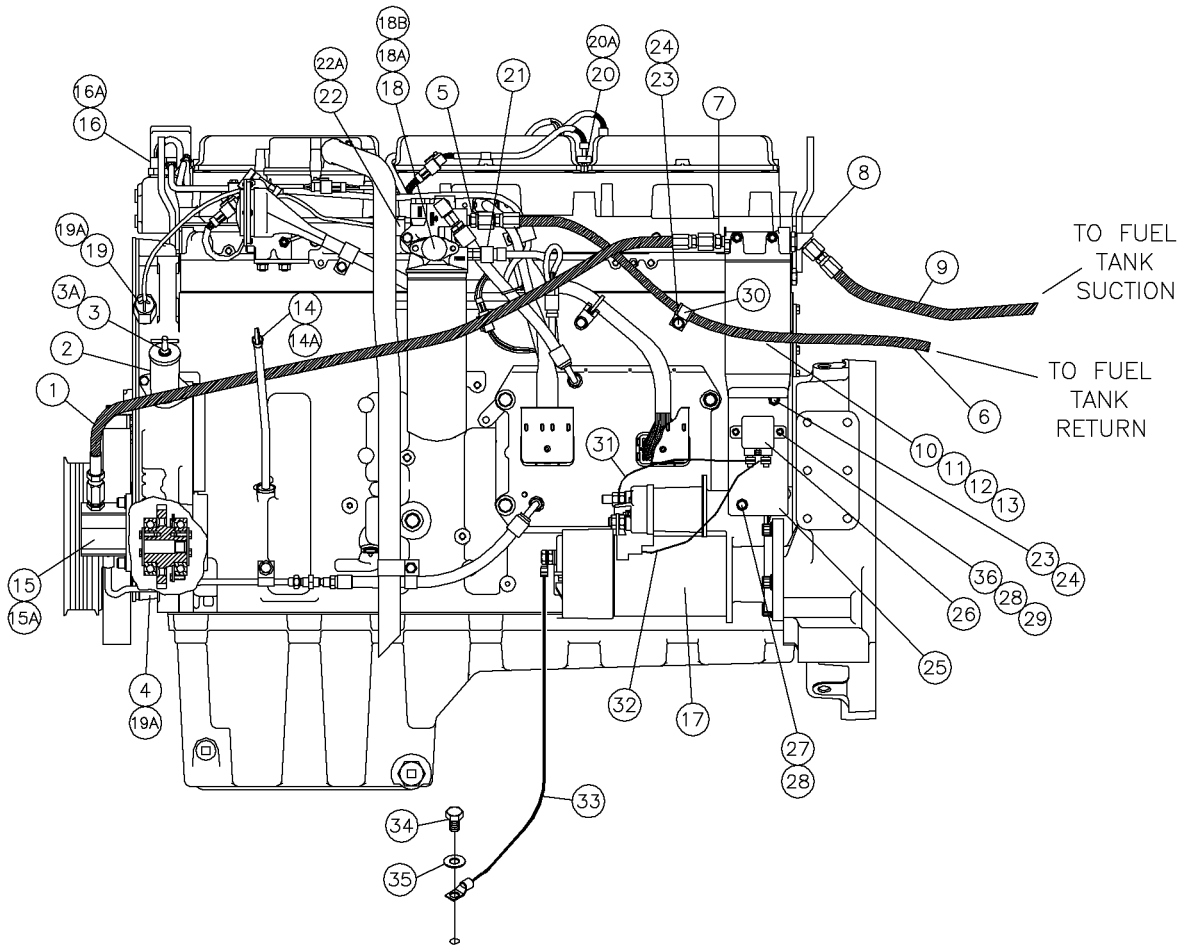

Engine Components Fig 3-2

REF. NO.	*	PART NO.	DESCRIPTION	QTY.	REMARKS
1		296258477	HOSE - FUEL 10 X 53 10FS JIC ST/ST 500 PSI	1	
2		296258443	TUBE - OIL FILL(MACHINED)	1	
3		296261905	FILLER CAP	1	
3A		296261906	RUBBER SEAL	1	
4		296261918	SENSOR	1	
5		101509001	COUPLING-10F JIC DIAGNOSTIC	1	
6		296258478	HOSE - FUEL - 10 X132 10FS JIC ST/ST 500 PSI	1	
7		53827001	FITT.-#10M O-RING-#10M JIC ST.	1	
8		56725001	FITTING-10MX10M JIC 45 DEG.	1	
9		296258479	HOSE - FUEL - 10 X 74 10FS JIC ST/ST 500 PSI	1	
10		111498001	FILTER-FUEL (COMPLETE)	1	
11		111498003	ELEMENT - FUEL FILTER	1	
12		111498005	BOWL ASSEMBLY FUEL FILTER	1	
13		111498007	HEAD - FUEL FILTER	1	
14		296261904	DIPSTICK	1	
14A		296261909	DIPSTICK TUBE	1	
15		296261910	PUMP - FUEL	1	
15A		296261911	GASKET	1	
16		296261892	SENSOR	1	
16A		296261913	O - RING	1	
17		601907001	STARTER ASSEMBLY	1	
18		296261914	FUEL PRIMING PUMP	1	
18A		121490001	GASKET-FUEL PRIMING	1	
18B		154657001	FILTER - FUEL 2 MICRON	1	
19		296261907	SENSOR	1	
19A		296261908	O - RING	2	
20		296261919	SENSOR - ATMOSPHERIC PRESSURE	1	
20A		296261920	O - RING	1	
21		296261898	SENSOR - OIL PRESSURE	1	
22		296261892	SENSOR	1	
22A		296261893	O - RING	1	
23		508476020	SCREW-HCS,M10- 1.50X20,10.9,YZ,ISO4017,FT	2	

Engine Components (Continued) Fig 3-2

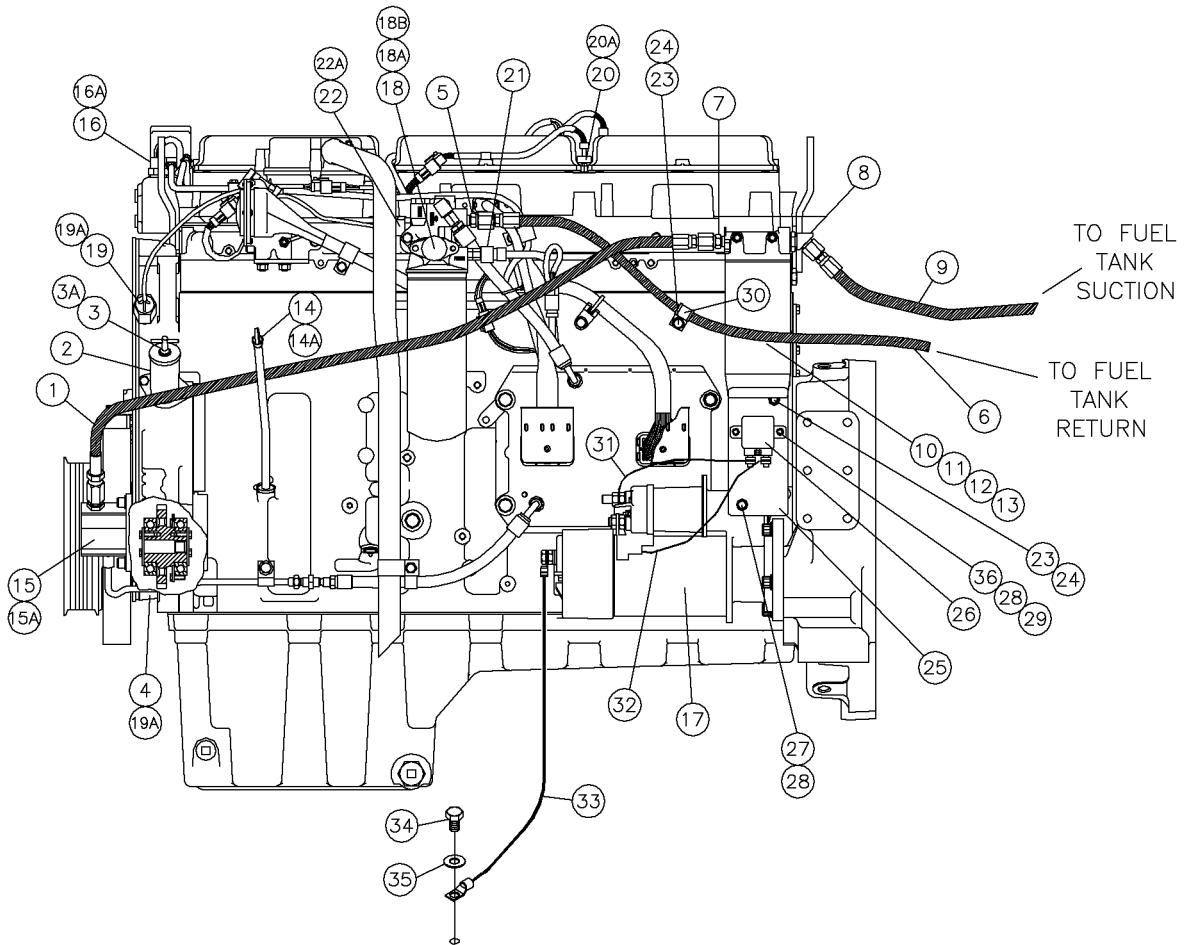

Engine Components (Continued) Fig 3-2

REF. NO.	*	PART NO.	DESCRIPTION	QTY.	REMARKS
24		235713001	WASHER-3/8 SAE HARD ZINC PLTD	2	
25		283108001	MOUNTING BRACKET START RELAY	1	
26		283033001	START RELAY	1	
27		508475020	SCREW-HCS,M8-1,25X20,10.9,YZ,ISO4017,FT.	1	
28		235714001	WASHER-5/16 SAE HARD ZINC PLTD	3	
29		235741001	NUT-5/16-18 GR8 ZINC PLTD	2	
30		2595013	CLAMP-1"HOSE W/VINYL COAT	3	
31		283139001	WIRING HARNESS-START RELAY POWER	1	
32		283138001	WIRING HARNESS-STARTING MOTOR CONTROL	1	
33		283135001	CABLE-CHASIS GROUND	1	
34		235728001	BOLT-1/2-13X3/4 GR8 ZINC PLTD	1	
35		485025	WASHER-1/2 FLAT-HARDENED-ZINC	1	
36		235742001	BOLT-5/16-18X3/4 GR8 ZINC PLTD	2	

Engine - Pully Drive Assy Fig 3-3r02

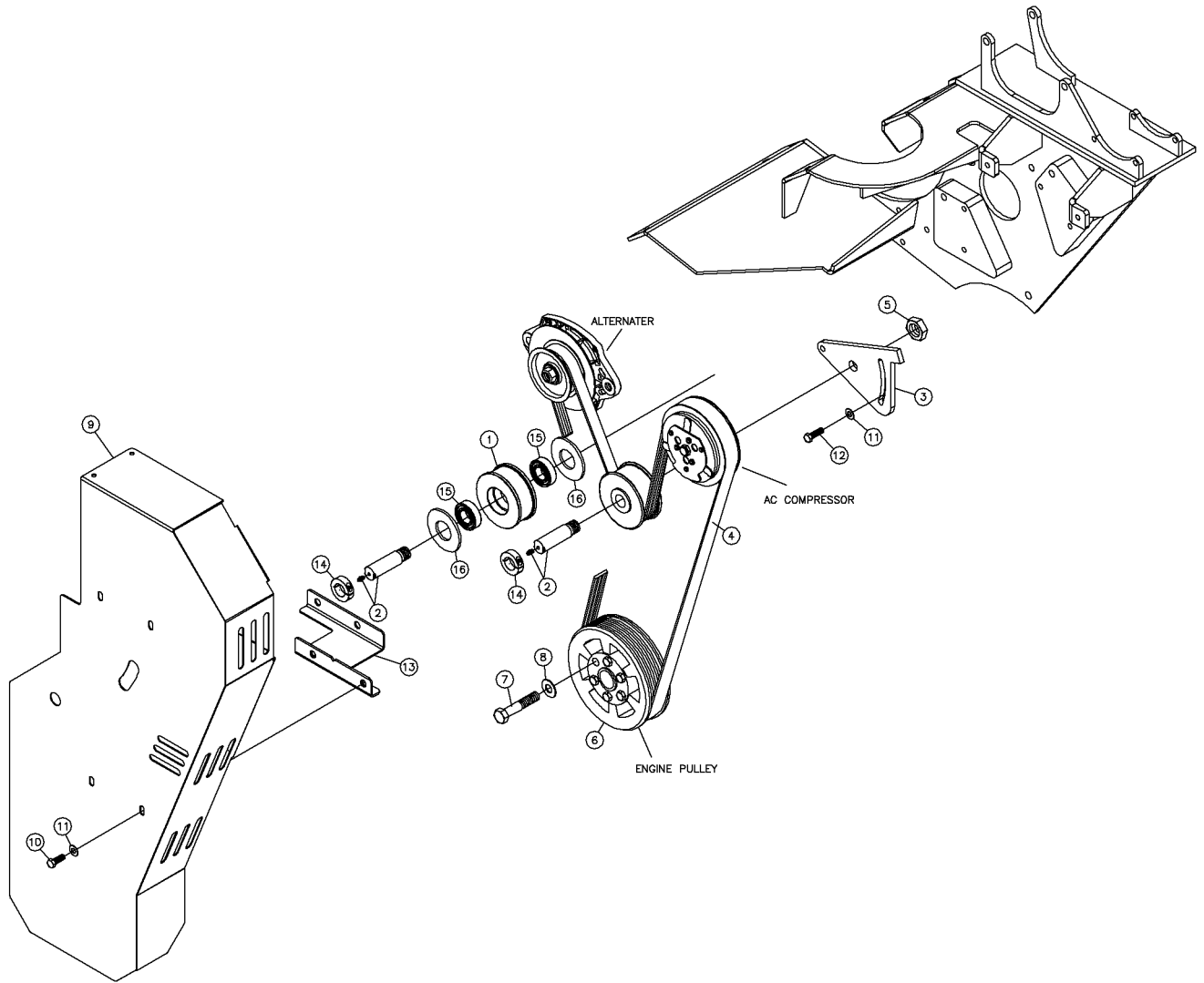

Engine - Pully Drive Assy Fig 3-3r02

REF. NO.	*	PART NO.	DESCRIPTION	QTY.	REMARKS
		Revision Date	October, 2004		Update In Illustration & Parts List.
1		296267881	SHEAVE - 4 OD X 2.5 WIDE	2	
2		296262582	SHAFT - IDLER	2	
3		296262596	PLATE - IDLER TIGHTENER	1	
4		296262583	BELT - K POLY - V 8 RIB	1	
5		510320311	NUT-HEXJAM-.75-10-GR2-YZ	1	
6		296264506	PLATE - LEFT HOSE TRACK	1	
7		508478085	SCREW-HCS,M16-2.00X85,10.9,YZ,ISO4017,FT	6	
8		603946001	WASHER M16	6	
9		296262600	GUARD	1	
10		235727001	BOLT-3/8-16X1 GR8 HEX ZINC PLT	7	
11		235713001	WASHER - FLATSTRL - .38 - .41 X .81 - .06-YA-A325	7	
12		235736001	BOLT-3/8-16X1 1/4 ZINC PLTD	3	
13		296262598	BOTTOM GUARD MOUNT	1	
14		296267796	COLLAR - 1" CLAMP - ONE - PIECE	2	
15		296267883	BEARING-RADIAL BALL 1.00 IDX2.0742ODX.59	4	
16		483005	WASHER-1 1/2X1X14 GA M.B.	A/R	P/N Qty. Of 1 = 1 Each

Engine - Pully Drive Assy Fig 3-3r01

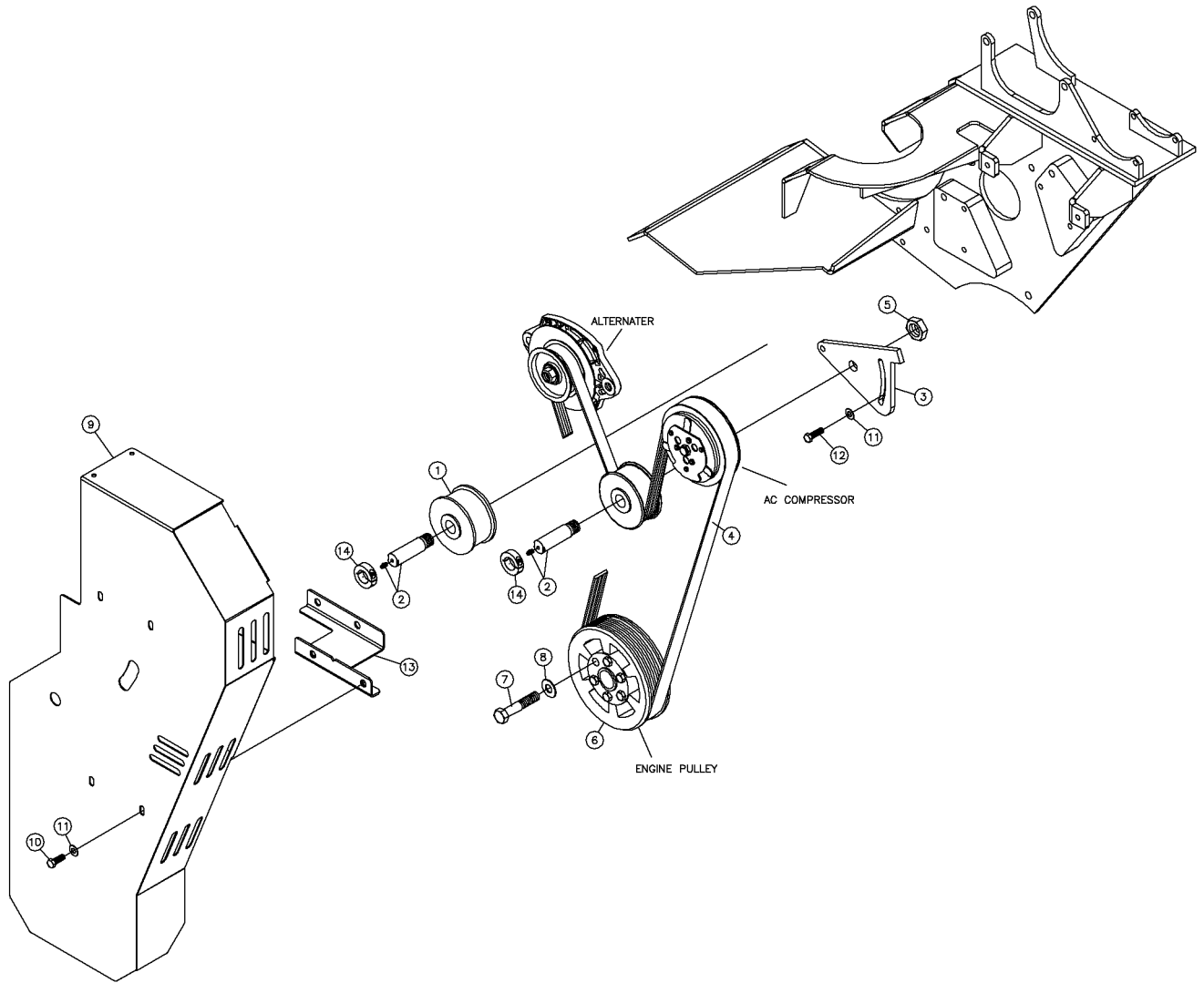

Engine - Pully Drive Assy Fig 3-3r01

REF. NO.	*	PART NO.	DESCRIPTION	QTY.	REMARKS
		Revision Date	June, 2002		Update In Illustration & Parts List.
1		296262581	PULLEY - IDLER	2	
2		296262582	SHAFT - IDLER	2	
3		296262596	PLATE - IDLER TIGHTENER	1	
4		296262583	BELT - K POLY - V 8 RIB	1	
5		510320311	NUT-HEXJAM-.75-10-GR2-YZ	1	
6		296264506	PULLEY-9" DIA K POLY-V 8 RIB	1	
7		508478085	SCREW-HCS,M16-2.00X85,10.9,YZ,ISO4017,FT	6	
8		603946001	WASHER M16	6	
9		296262600	GUARD	1	
10		235727001	BOLT-3/8-16X1 GR8 HEX ZINC PLT	7	
11		235713001	WASHER-3/8 SAE HARD ZINC PLTD	7	
12		235736001	BOLT-3/8-16X1 1/4 ZINC PLTD	3	
13		296262598	BOTTOM GUARD MOUNT	1	
14	*	296267796	COLLAR - 1" CLAMP - ONE - PIECE	2	

Engine - Pully Drive Assy Fig 3-3

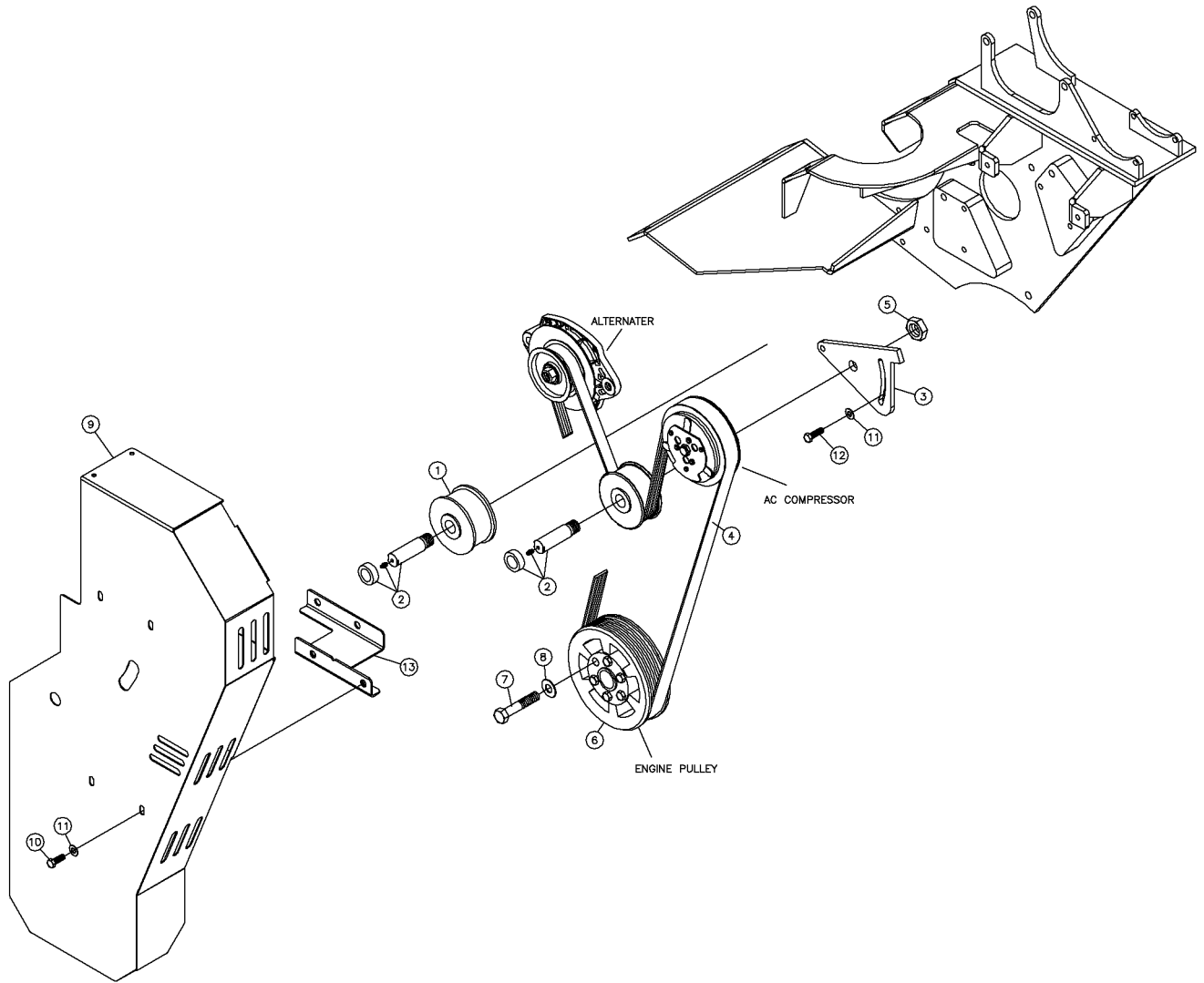

Engine - Pully Drive Assy Fig 3-3

REF. NO.	*	PART NO.	DESCRIPTION	QTY.	REMARKS
1		296262581	PULLEY - IDLER	2	
2		296262582	SHAFT - IDLER	2	
3		296262596	PLATE - IDLER TIGHTENER	1	
4		296262583	BELT - K POLY - V 8 RIB	1	
5		510320311	NUT-HEXJAM-.75-10-GR2-YZ	1	
6		296264506	PULLEY-9" DIA K POLY-V 8 RIB	1	
7		508478085	SCREW-HCS,M16-2.00X85,10.9,YZ,ISO4017,FT	6	
8		603946001	WASHER M16	6	
9		296262600	GUARD	1	
10		235727001	BOLT-3/8-16X1 GR8 HEX ZINC PLT	7	
11		235713001	WASHER-3/8 SAE HARD ZINC PLTD	7	
12		235736001	BOLT-3/8-16X1 1/4 ZINC PLTD	3	
13		296262598	BOTTOM GUARD MOUNT	1	

Engine - Alternator Assy Fig 3-4

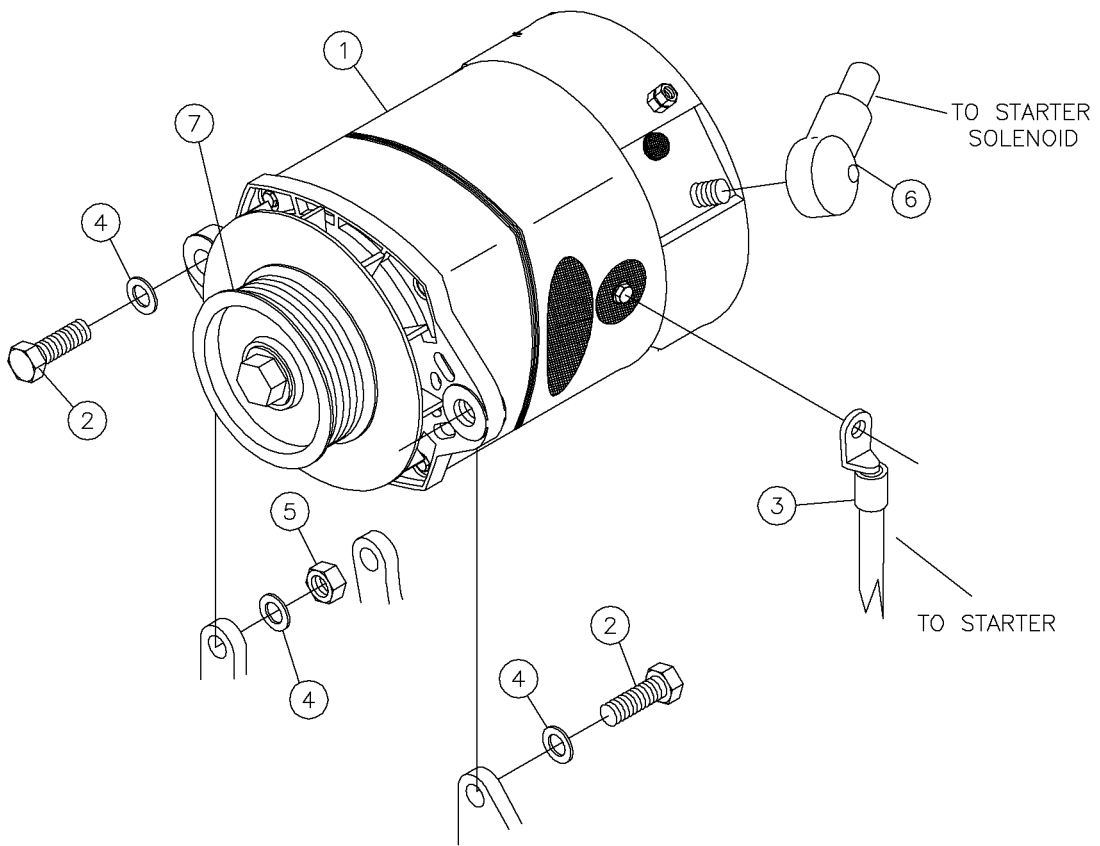

Engine - Alternator Assy Fig 3-4

REF. NO.	*	PART NO.	DESCRIPTION	QTY.	REMARKS
1		296262585	ALTERNATOR-24 VOLT 75 AMP 26SI	1	
2		235721001	BOLT-1/2-13X1 1/2 GR8 ZINC PLT	3	
3		283137001	ALTERNATOR CABLE-GROUND	1	
4		485025	WASHER-1/2 FLAT-HARDENED-ZINC	5	
5		235731001	NUT-1/2-13 GR8 ZINC PLTD	2	
6		283136001	ALTERNATOR CABLE-CHARGING	1	
7		296262586	PULLEY-.875 ID K POLY-V 88RIB ALTERNATOR	1	

Engine - Pump Drive Assy Fig 3-5r01

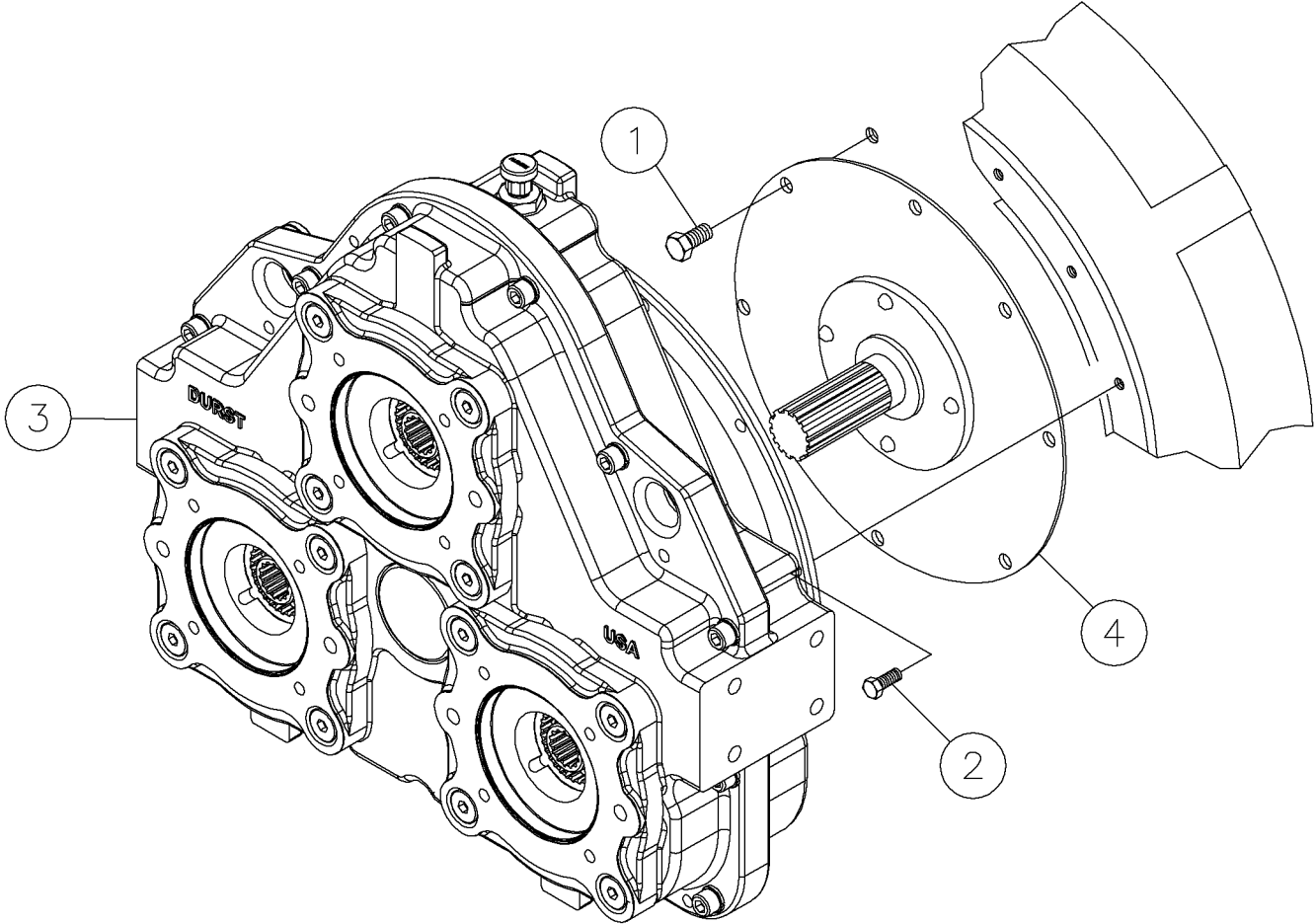

Engine - Pump Drive Assy Fig 3-5r01

REF. NO.	*	PART NO.	DESCRIPTION	QTY.	REMARKS
1		235729001	SCREW-HCS-.50-13X1.00-GR8-YZ	8	
2		250584001	7/16-14X1 1/4 GR8 HEX BOLT PL	12	
3		296273904	PUMP DRIVE	1	Breakdown Fig 12-25r01(Not Available)
4		296261936	DRIVE PLATE ASSEMBLY	1	

Engine - Pump Drive Assy Fig 3-5

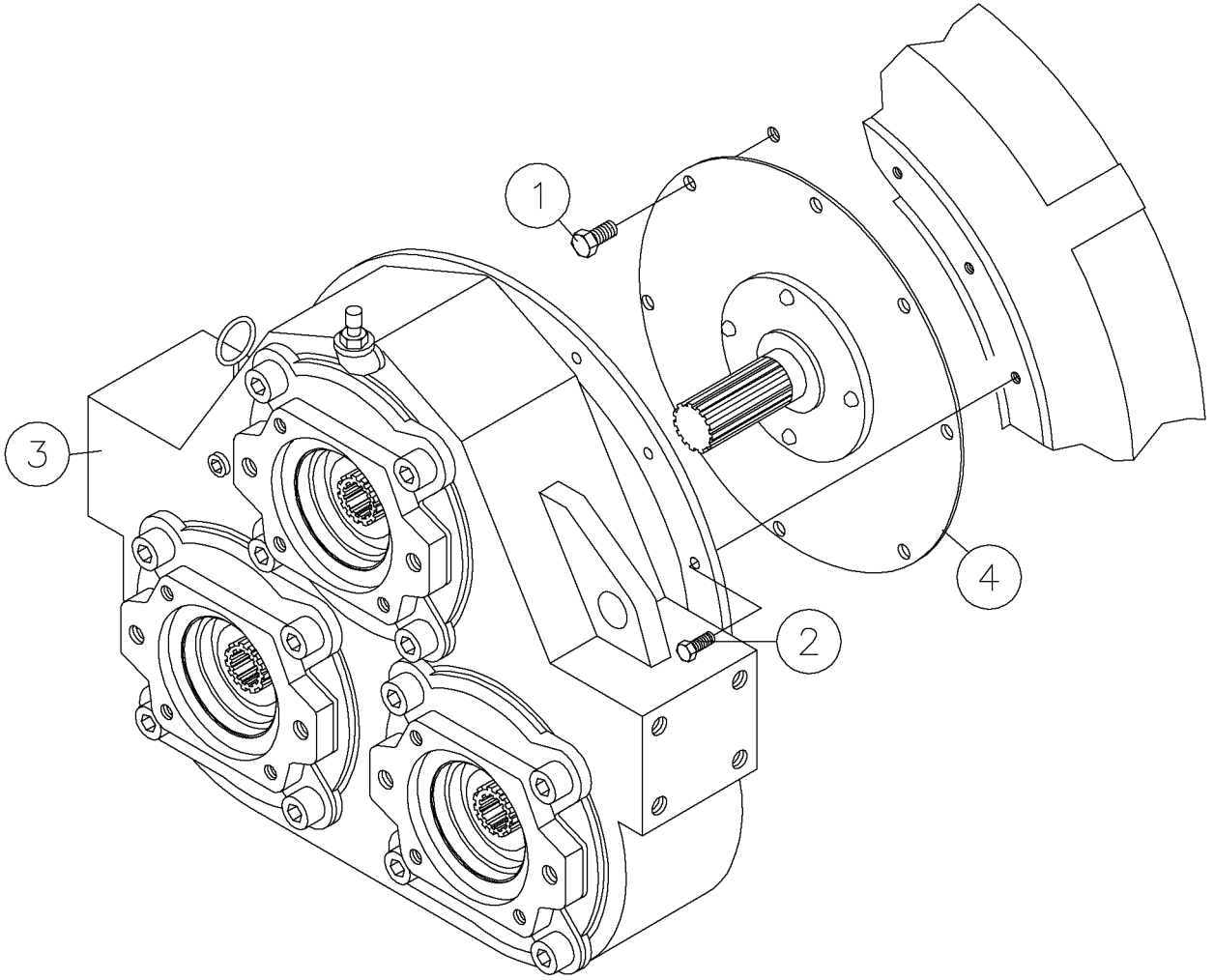

Engine - Pump Drive Assy Fig 3-5

REF. NO.	*	PART NO.	DESCRIPTION	QTY.	REMARKS
1		235729001	SCREW-HCS-.50-13X1.00-GR8-YZ	8	
2		250584001	7/16-14X1 1/4 GR8 HEX BOLT PL	12	
3		296261937	PUMP DRIVE	1	Breakdown Fig 12-25
4		296261936	DRIVE PLATE ASSEMBLY	1	

Engine - Remote Oil Filter Assy Fig 3-6r01

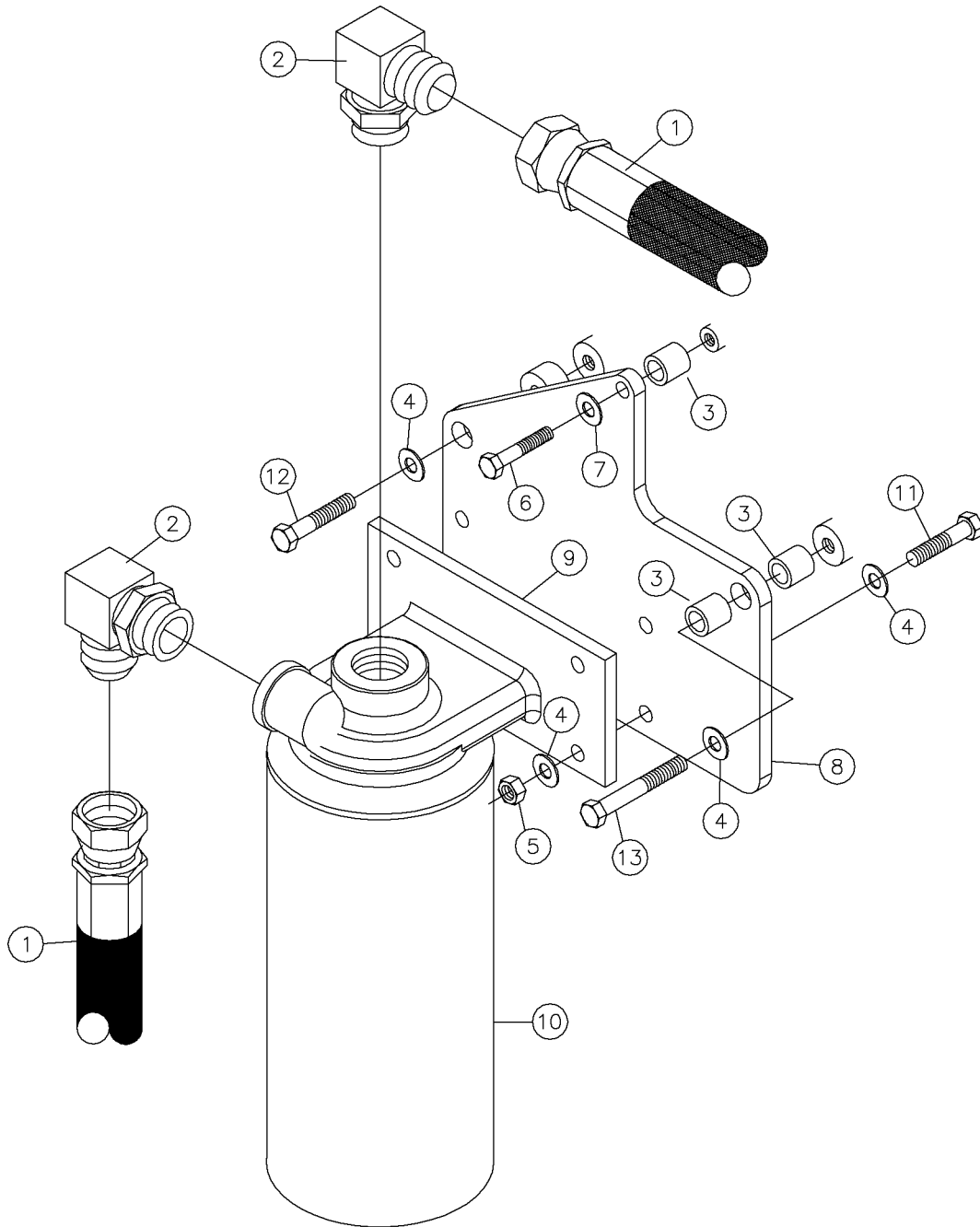

Engine - Remote Oil Filter Assy Fig 3-6r01

REF. NO.	*	PART NO.	DESCRIPTION	QTY.	REMARKS
		Revision Date	June, 2002		Update In Illustration & Parts List.
1		296261891	HOSE - REMOTE OIL	2	
2		61703001	FITTING-16M X 16M JIC 90	2	
3	*	296257395	SPACER - OIL FILTER PLATE	4	
4		235713001	WASHER-3/8 SAE HARD ZINC PLTD	10	
5		235725001	NUT-3/8-16 GR8 ZINC PLTD	4	
6		506032045	SCREW-HCS,M8-1.25X45,8.8,YZ,D931,PT	1	
7		235714001	WASHER-5/16 SAE HARD ZINC PLTD	1	
8		296256372	PLATE - FILTER MOUNT	1	
9		296261923	HEAD - OIL FILTER	1	
10		601896001	FILTER-OIL	1	
11		235723001	BOLT-3/8-16X1 1/2 GR8 ZINC PLT	4	
12		508476050	SCREW-HCS,M10-1.50,10.9,YZ,ISO4014,PT	1	
13		508476070	SCREW-HCS,M10-1.50X70,10.9,YZ,ISO4014PT	1	

Engine - Remote Oil Filter Assy Fig 3-6

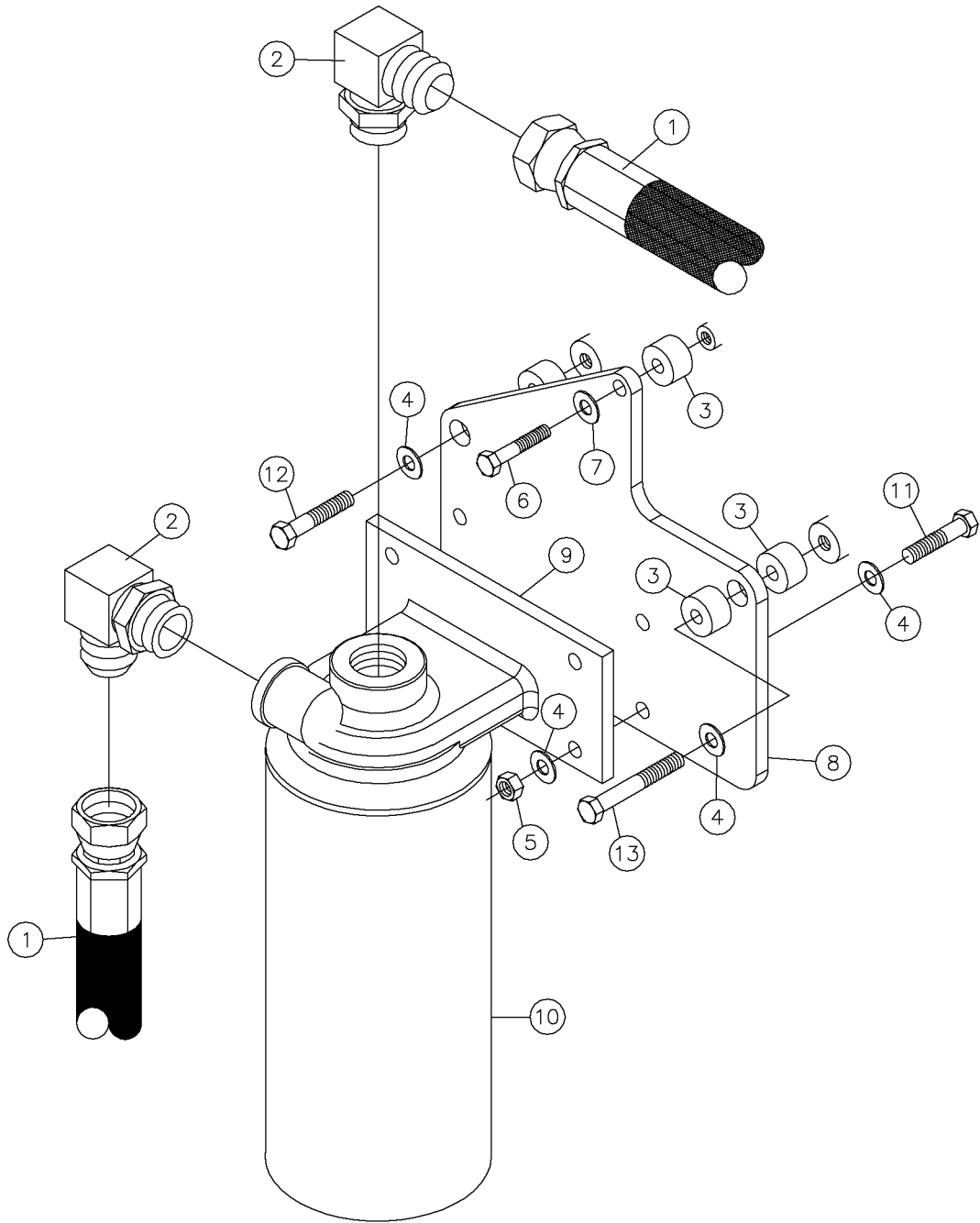

Engine - Remote Oil Filter Assy Fig 3-6

REF. NO.	*	PART NO.	DESCRIPTION	QTY.	REMARKS
1		296261891	HOSE - REMOTE OIL	2	
2		61703001	FITTING-16M X 16M JIC 90	2	
3		228152001	BRZ BUSHING- .753X.503-.625	4	
4		235713001	WASHER-3/8 SAE HARD ZINC PLTD	10	
5		235725001	NUT-3/8-16 GR8 ZINC PLTD	4	
6		506032045	SCREW-HCS,M8-1.25X45,8.8,YZ,D931,PT	1	
7		235714001	WASHER-5/16 SAE HARD ZINC PLTD	1	
8		296256372	PLATE - FILTER MOUNT	1	
9		296261923	HEAD - OIL FILTER	1	
10		601896001	FILTER-OIL	1	
11		235723001	BOLT-3/8-16X1 1/2 GR8 ZINC PLT	4	
12		508476050	SCREW-HCS,M10-1.50,10.9,YZ,ISO4014,PT	1	
13		508476070	SCREW-HCS,M10-1.50X70,10.9,YZ,ISO4014PT	1	

Engine - Fan Assy Fig 3-7

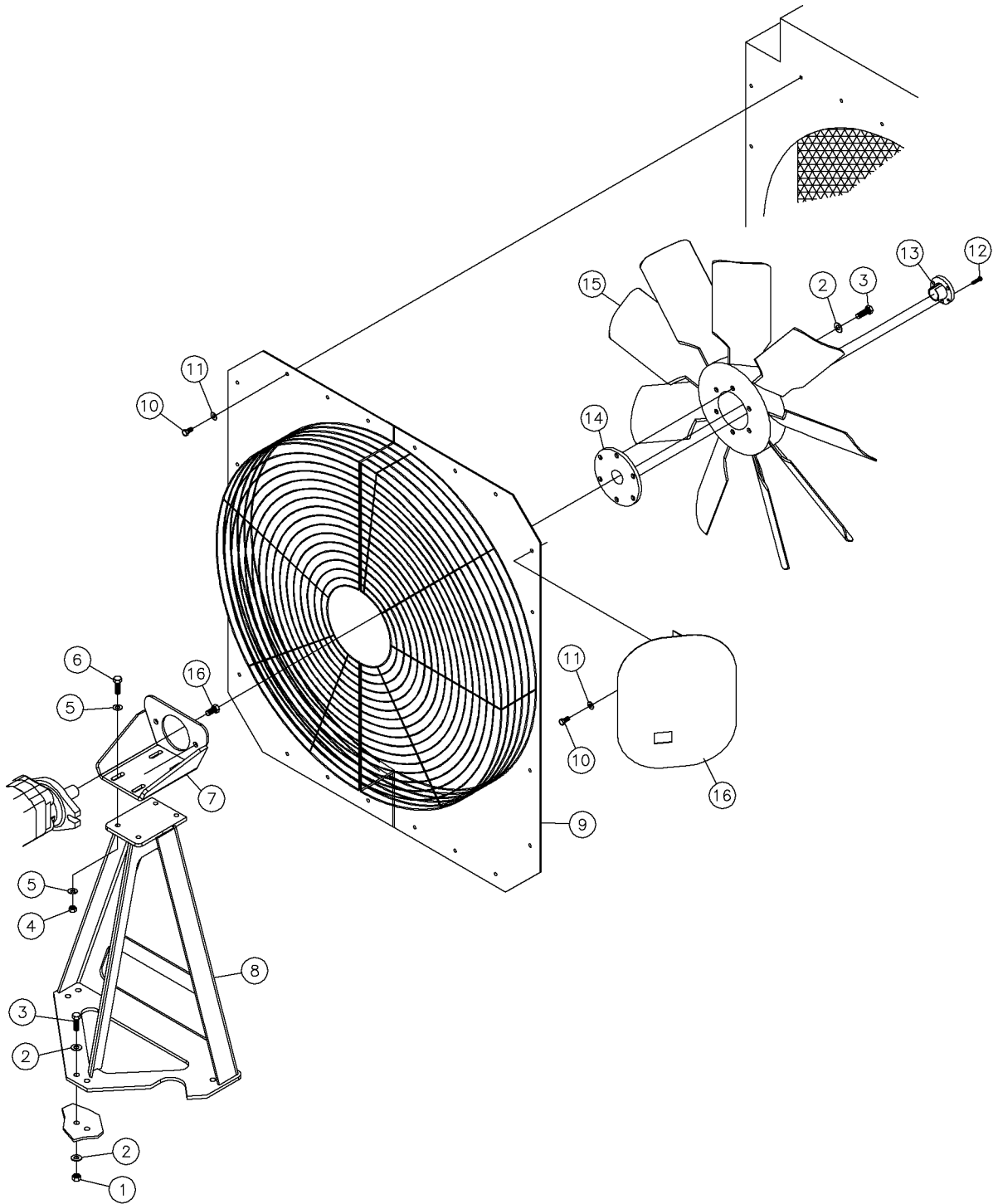

Engine - Fan Assy Fig 3-7

REF. NO.	*	PART NO.	DESCRIPTION	QTY.	REMARKS
1		235731001	NUT-1/2-13 GR8 ZINC PLTD	6	
2		485025	WASHER-1/2 FLAT-HARDENED-ZINC	18	
3		235721001	BOLT-1/2-13X1 1/2 GR8 ZINC PLT	12	
4		233459001	NUT-7/16-14 GR.8 HEX YZ	4	
5		250515001	7/16 HARD WASHER SAE Y/ZINC	8	
6		250506001	BOLT 7/16-14 X 1 1/2" GR8 HEX	4	
7		296256406	MOUNT - FAN STAND MOTOR	1	
8		296256405	FAN STAND - WELDMENT	1	
9		296261917	GUARD-FAN	2	
10		235726001	BOLT-3/8-16X3/4 GR8 HEX ZNCPLT	20	
11		235713001	WASHER-3/8 SAE HARD ZINC PLTD	20	
12		238209001	BOLT-5/16-18X1 GR8 NEX ZINC YC	3	
13		293599001	HUB - TAPPED W/ 5/16 X 5/32 KEYWAY	1	
14		296262619	HUB - FAN	1	
15		296261916	FAN	1	
16		293749001	SHIELD - HEAT	1	

Engine - Radiator Assy Fig 3-8

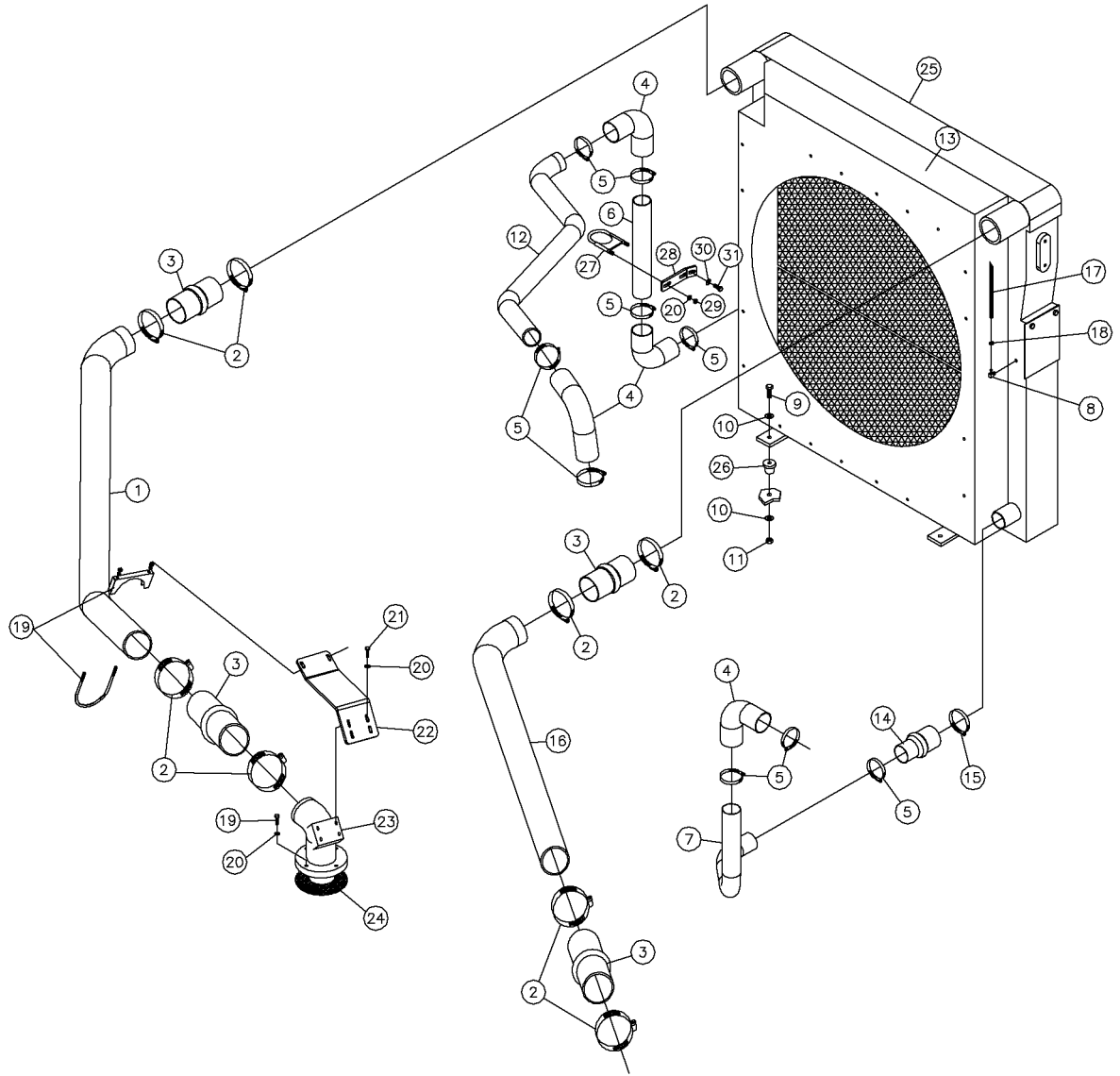

Engine - Radiator Assy Fig 3-8

REF. NO.	*	PART NO.	DESCRIPTION	QTY.	REMARKS
1		293746001	TUBE CHARGED AIR	1	
2		91432001	CLAMP - 4 1/2" T-BOLT	8	
3		296261921	HOSE - HUMP	4	
4		296256464	ELBOW - 2.5" ID X 90 DEG RUBBER	4	
5		101514001	CLAMP-3IN. T-BOLT	9	
6		296256392	TUBE-SIDE RADIATOR	1	
7		296256257	TUBE LOWER RADIATOR	1	
8		83124001	FITTING- #1556 WTHR-HD	1	
9		381022	BOLT-7/16-14X2 1/4 HEX GR. 8	3	
10		250515001	7/16 HARD WASHER SAE Y/ZINC	6	
11		233459001	NUT-7/16-14 GR.8 HEX YZ	3	
12		296256258	TUBE-UPPER RADIATOR	1	
13		296258441	ASSEMBLY - ENGINE RADIATOR SHROUD	1	
14		296261922	HOSE - REDUCING HUMP	1	
15		296261925	CLAMP - HOSE	1	
16		293745001	TUBE - CHARGED AIR	1	
17		620001	HOSE - 5/16 FUEL LINE	A/R	P/N Qty Of 1 = 1 Foot
18		1580001	HOSE CLAMP - 3/8"	1	
19		508475030	SCREW-HCS,M8-1,25X30,10.9,YZ,ISO4017,FT.	4	
20		235714001	WASHER-5/16 SAE HARD ZINC PLTD	10	
21		250520001	BOLT -8M X 1.25 25M GR8 Y/ZINC	4	
22		296256284	BRACE CHARGED AIR	1	
23		296261977	ELBOW	1	
24		296261978	GASKET	1	
25		296264807	RADIATOR	1	
26		296264808	MOUNT-RUBBER	4	S/N 105-
27		296256462	U - BOLT - 2.5" GUILLOTINE BOLT	1	S/N 105-
28		296256442	BRACKET - RADIATOR TUBE	1	S/N 105-
29		235741001	NUT-5/16-18 GR8 ZINC PLTD	2	
30		235713001	WASHER-3/8 SAE HARD ZINC PLTD	1	
31		235727001	BOLT-3/8-16X1 GR8 HEX ZINC PLT	1	

Engine - Ether Start Assy Fig 3-9r01

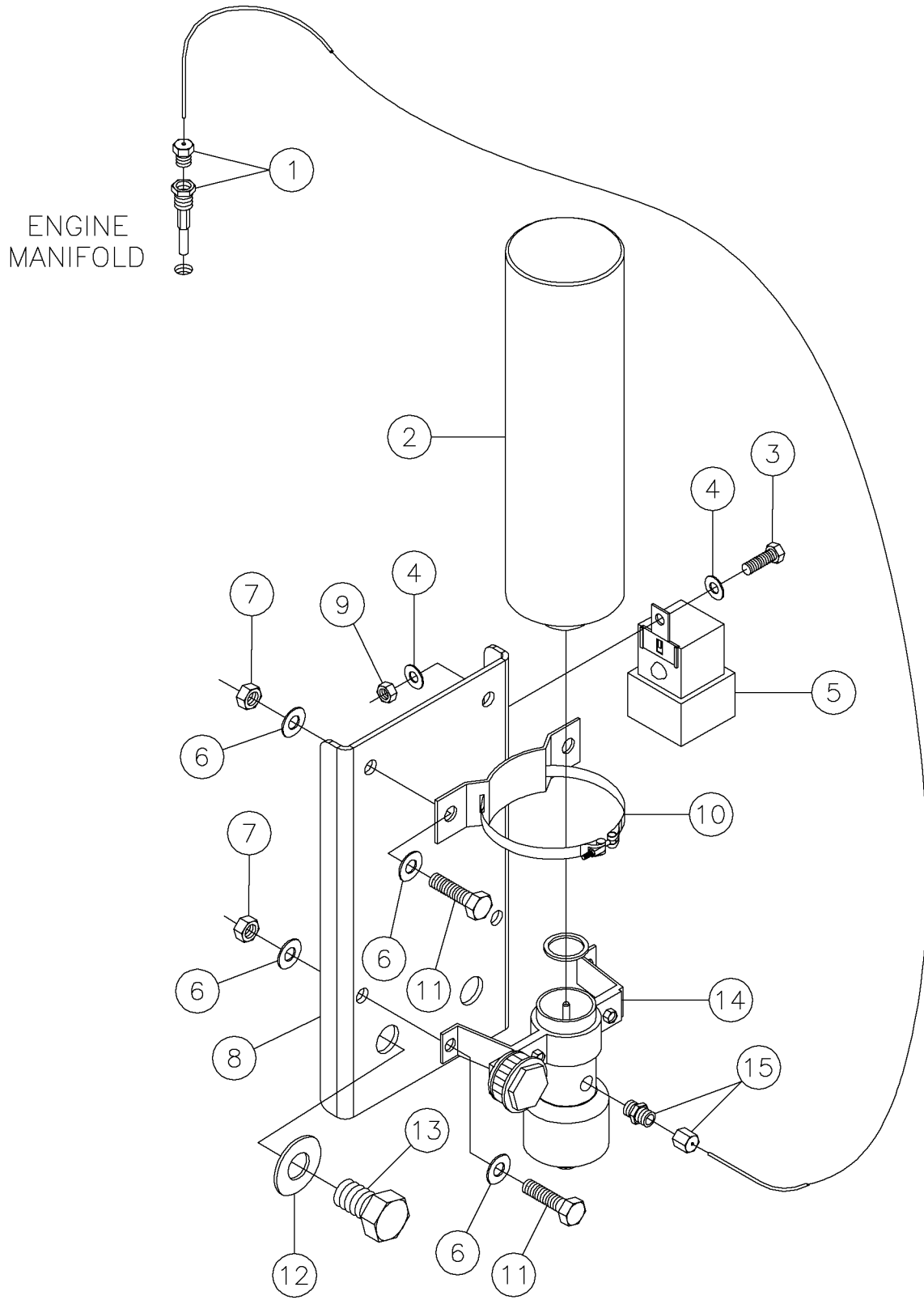

Engine - Ether Start Assy Fig 3-9r01

REF. NO.	*	PART NO.	DESCRIPTION	QTY.	REMARKS
		Revision Date	October, 2004		Update In Illustration & Parts List.
1		296261967	ATOMIZER	1	
2		296261963	CYLINDER - START FLUID	1	
3		235734001	BOLT-1/4-20X3/4 GR8 ZINC PLTD	1	
4		235716001	WASHER - FLATSTRL - .25 - .28 X .63 - .06 - CZ	2	
5		296261969	RELAY	1	
6		235714001	WASHER - FLATSTRL - .31 - .34 X .69 - .06-YZ-A325	8	
7		235741001	NUT - HEX - .31 - 18 - GR8 -YZ	4	
8		296262531	BRACKET - ETHER START	1	
9		235732001	NUT - HEX - .25 - 20 - GR8 - YZ	1	
10		296261964	CLAMP	1	
11		235741001	NUT - HEX - .31 - 18 - GR8 -YZ	4	
12		235715001	WASHER-5/8 SAE HARD ZINC PLTD	2	
13		244211001	BOLT-5/8-11X1 GR8 HEX ZINC PLTD	2	
14		296261965	VALVE - SOLENOID	1	
15		296261966	CONNECTOR	1	

Engine - Ether Start Assy Fig 3-9

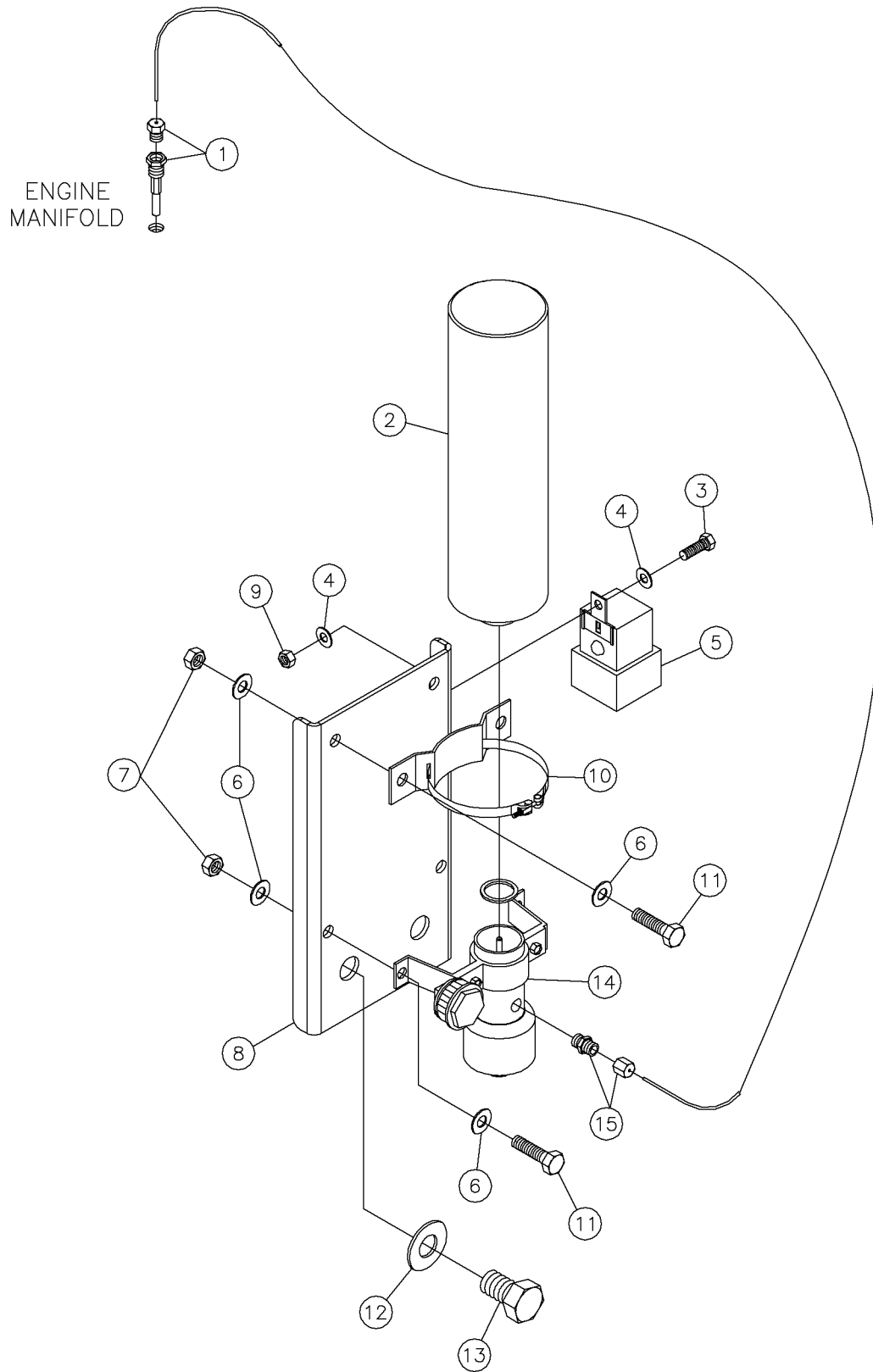

Engine - Ether Start Assy Fig 3-9

REF. NO.	*	PART NO.	DESCRIPTION	QTY.	REMARKS
1		296261967	ATOMIZER	1	
2		296261963	CYLINDER - START FLUID	1	
3		235734001	BOLT-1/4-20X3/4 GR8 ZINC PLTD	1	
4		235716001	WASHER-1/4 SAE HARD ZINC PLTD	2	
5		269261969	RELAY	1	
6		235714001	WASHER-5/16 SAE HARD ZINC PLTD	8	
7		235741001	NUT-5/16-18 GR8 ZINC PLTD	4	
8		296262531	BRACKET - ETHER START	1	
9		235732001	NUT-1/4-20 GR8 ZINC PLTD	1	
10		296261964	CLAMP	1	
11		235742001	BOLT-5/16-18X3/4 GR8 ZINC PLTD	4	
12		235715001	WASHER-5/8 SAE HARD ZINC PLTD	2	
13		244211001	BOLT-5/8-11X1 GR8 HEX ZINC PLTD	2	
14		296261965	VALVE - SOLENOID	1	
15		296261966	CONNECTOR	1	

Engine - Muffler Assy Fig 3-10r01

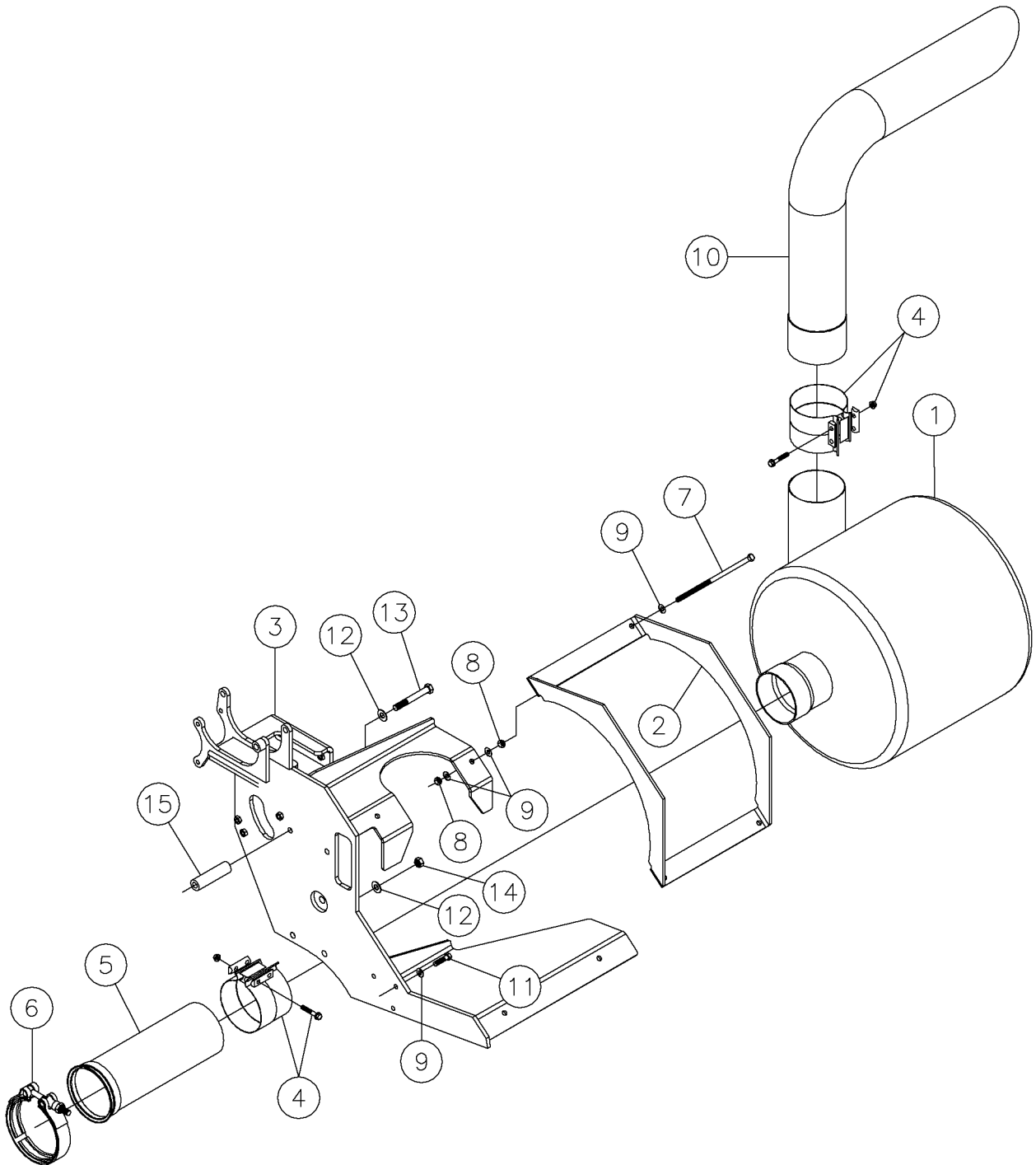

Engine - Muffler Assy Fig 3-10r01

REF. NO.	*	PART NO.	DESCRIPTION	QTY.	REMARKS
		Revision Date	October, 2004		Update In Illustration.
1		288979001	MUFFLER-COWL #TXS50PR	1	
2		293663001	PLATE MUFFLER CLAMP	1	
3		296262587	BRACKET - ENGINE MULTI-MOUNT	1	
4		601476001	CLAMP-5" TORCTITE EXHAUST	2	
5		296256439	TUBE - EXHAUST	1	
6		296263295	CLAMP	1	
7		278275001	BOLT-3/8-16X9 GR 8 ZINC PLTD	4	
8		235725001	NUT - HEX - .38 - 16 - GR8 - YZ	4	
9		235713001	WASHER - FLATSTRL - .38 - .41 X .81 - .06-YA-A325	14	
10		296262535	TUBE - EXHAUST	1	
11		235727001	BOLT-3/8-16X1 GR8 HEX ZINC PLT	2	
12		485025	WASHER-1/2 FLAT-HARDENED-YZ	4	
13		507407120	SCREW-HCS,M12-1.75X120,10.9,YZ,ISO4017,PT	2	
14		507090012	NUT-HEX,M12-1.75,CL10,YZ,ISO4032	2	
15		296264805	SPACER	2	

Engine - Muffler Assy Fig 3-10

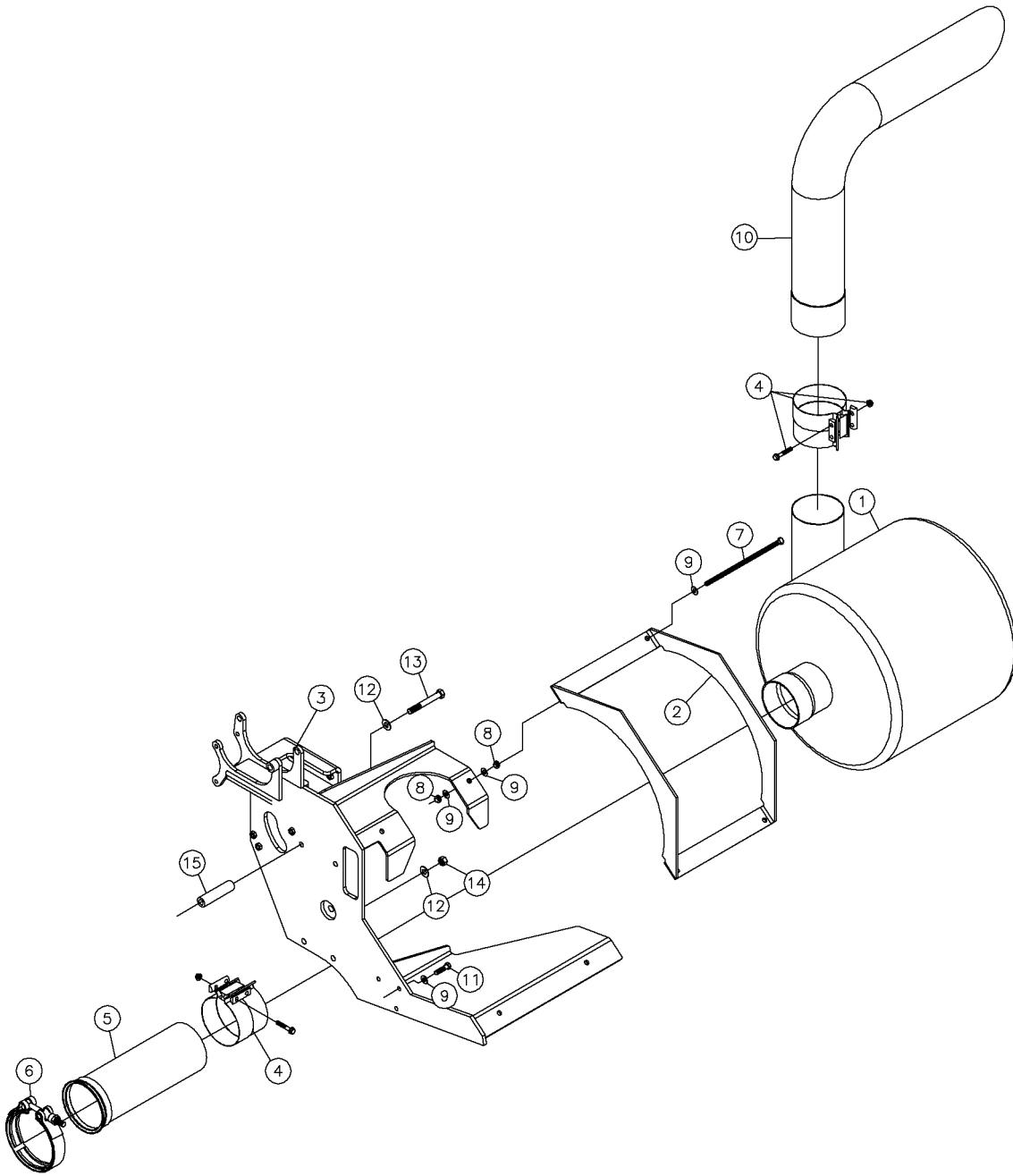

Engine - Muffler Assy Fig 3-10

REF. NO.	*	PART NO.	DESCRIPTION	QTY.	REMARKS
1		288979001	MUFFLER-COWL #TXS50PR	1	
2		293663001	PLATE MUFFLER CLAMP	1	
3		296262587	BRACKET - ENGINE MULTI-MOUNT	1	
4		601476001	CLAMP-5" TORCTITE EXHAUST	2	
5		296256439	TUBE - EXHAUST	1	
6		296263295	CLAMP	1	
7		278275001	BOLT-3/8-16X9 GR 8 ZINC PLTD	4	
8		235725001	NUT-3/8-16 GR8 ZINC PLTD	4	
9		235713001	WASHER-3/8 SAE HARD ZINC PLTD	14	
10		296262535	TUBE - EXHAUST	1	
11		235727001	BOLT-3/8-16X1 GR8 HEX ZINC PLT	2	
12		485025	WASHER-1/2 FLAT-HARDENED-ZINC	4	
13		507407120	SCREW-HCS,M12-1.75X120,10.9,YZ,ISO4017,PT	2	
14		507090012	NUT-HEX,M12-1.75,CL10,YZ,ISO4032	2	
15		296264805	SPACER	2	

Engine - Air Cleaner Assy Fig 3-11r01

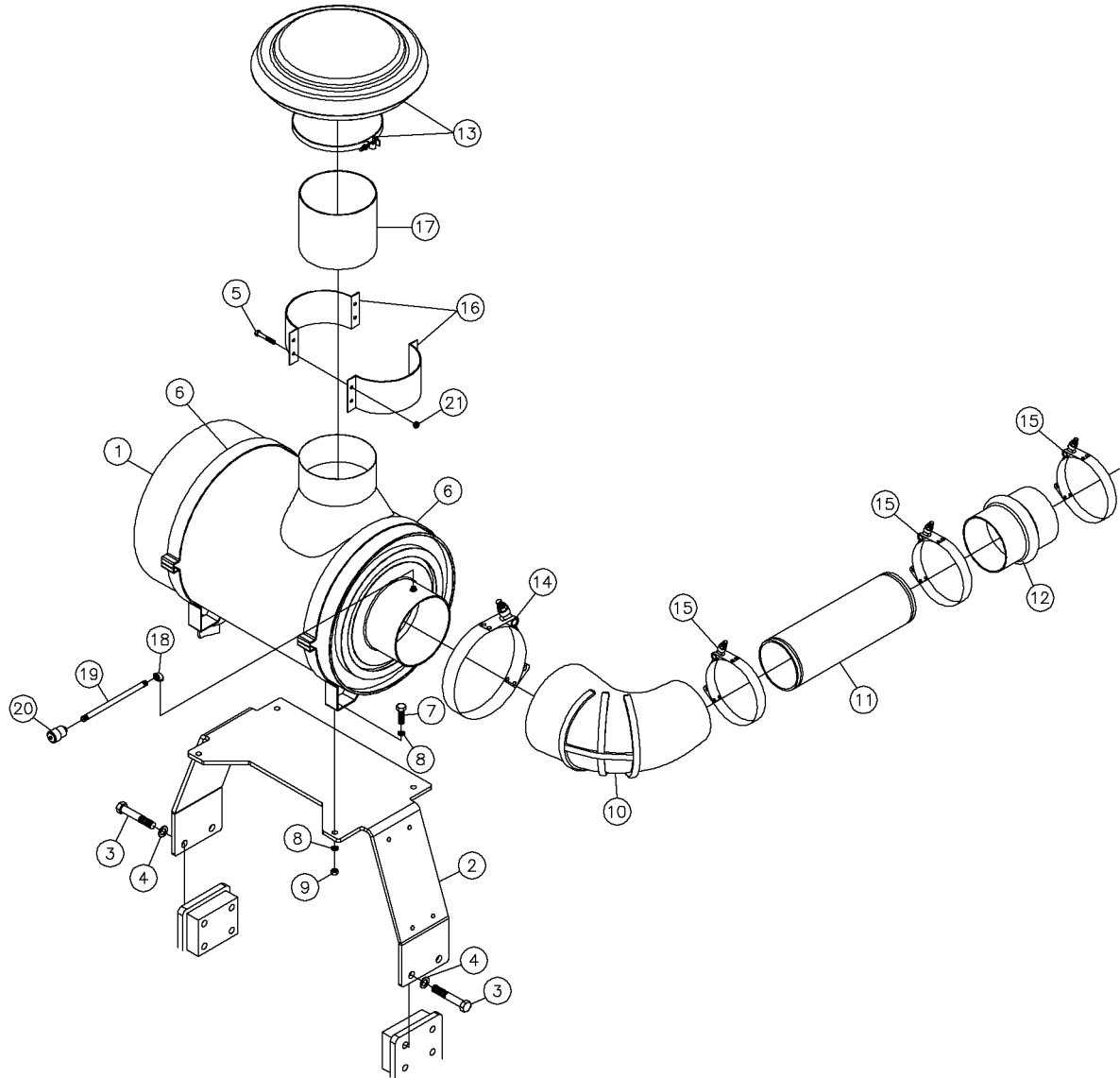

Engine - Air Cleaner Assy Fig 3-11r01

REF. NO.	*	PART NO.	DESCRIPTION	QTY.	REMARKS
		Revision Date	June, 2002		Update In Illustration.
1		293636001	AIR CLEANER - FVG 160587	1	Breakdown Fig12-28
2		293660001	PLATE - AIR CLEANER MOUNT	1	
3		238208001	BOLT 5/8 - 11 X 3 1/2 GR 8 HEX ZYC	4	
4		235715001	WASHER-5/8 SAE HARD ZINC PLTD	4	
5		4475020	BOLT-3/8-16X2 FLANGE WHIZ PLTD	4	
6		293684001	BRACKET-AIR CLEANER MOUNTING	2	
7		250506001	BOLT 7/16-14 X 1 1/2" GR8 HEX	4	
8		250515001	7/16 HARD WASHER SAE Y/ZINC	8	
9		233459001	NUT-7/16-14 GR.8 HEX YZ	4	
10		293701001	ELBOW-7.0-5.0 INTAKE REDUCING	1	
11		293743001	TUBE - INTAKE	1	
12		293702001	HOSE-5" HUMP	1	
13		296256460	CAP-INTAKE, 7"	1	Inc Clamp
14		91432007	CLAMP-7 3/4" T-BOLT	1	
15		141409001	CLAMP-T BOLT 5.31-5.59	3	
16		296262514	CLAMP - INTAKE	2	
17		296262503	TUBE - INTAKE EXTENSION	1	
18		93393001	FITTING-1/8"X90 DEG.ELBOW	1	
19		155446001	FITTING - 1/8 SCHD 40 X 8 NIPPLE	1	
20		296256686	INDICATOR - SERVICE	1	
21		510315411	NUT-HEXFLGL-38-16-GR2-YZ	4	

Engine - Air Cleaner Assy Fig 3-11

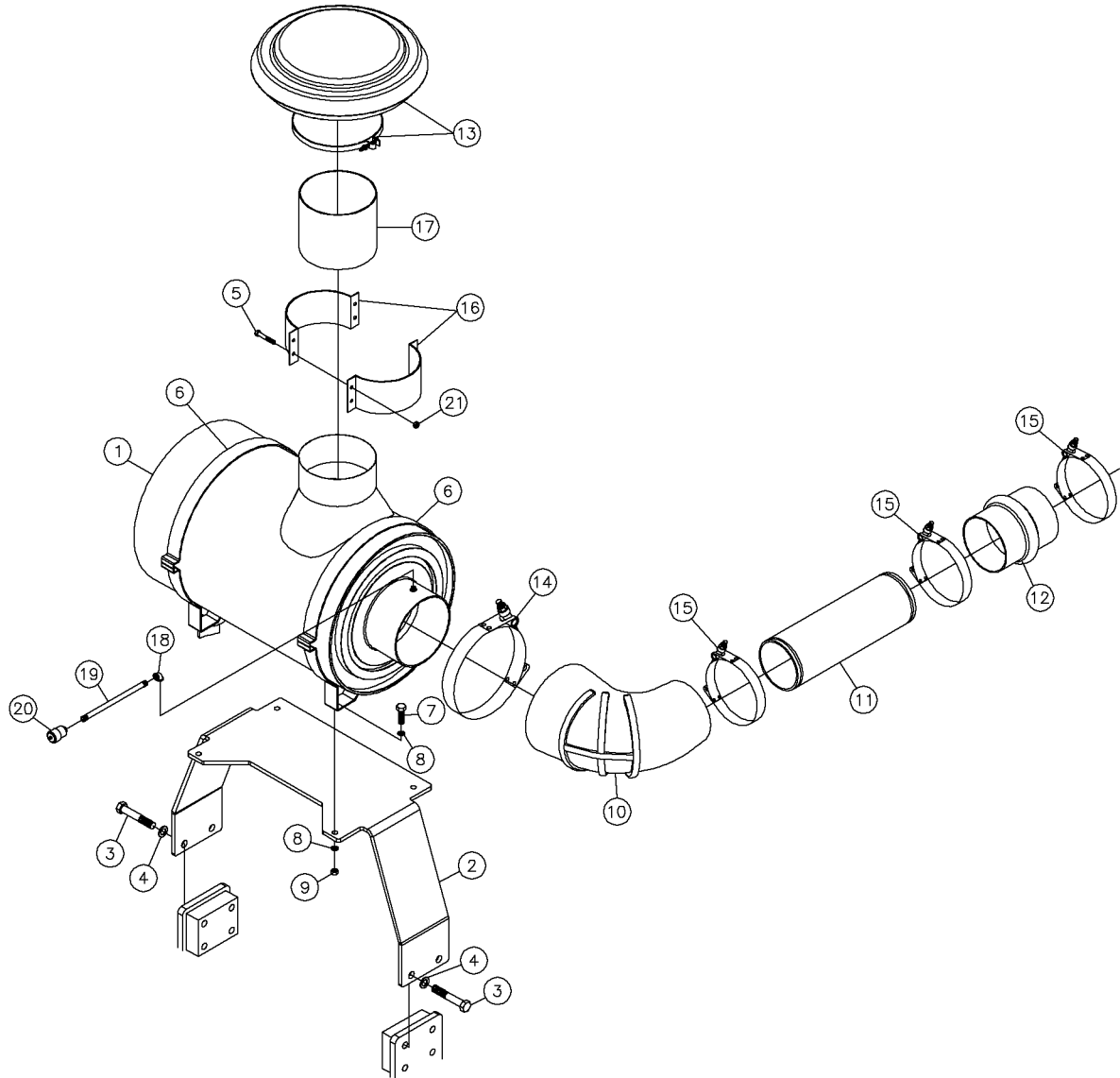

Engine - Air Cleaner Assy Fig 3-11

REF. NO.	*	PART NO.	DESCRIPTION	QTY.	REMARKS
1		293636001	AIR CLEANER - FVG 160587	1	Breakdown Fig12-28
2		293660001	PLATE - AIR CLEANER MOUNT	1	
3		238208001	BOLT 5/8 - 11 X 3 1/2 GR 8 HEX ZYC	4	
4		235715001	WASHER-5/8 SAE HARD ZINC PLTD	4	
5		4475020	BOLT-3/8-16X2 FLANGE WHIZ PLTD	4	
6		293684001	BRACKET-AIR CLEANER MOUNTING	2	
7		250506001	BOLT 7/16-14 X 1 1/2" GR8 HEX	4	
8		250515001	7/16 HARD WASHER SAE Y/ZINC	8	
9		233459001	NUT-7/16-14 GR.8 HEX YZ	4	
10		293701001	ELBOW-7.0-5.0 INTAKE REDUCING	1	
11		293743001	TUBE - INTAKE	1	
12		293702001	HOSE-5" HUMP	1	
13		296256460	CAP-INTAKE, 7"	1	Inc Clamp
14		91432007	CLAMP-7 3/4" T-BOLT	1	
15		141409001	CLAMP-T BOLT 5.31-5.59	3	
16		296262514	CLAMP - INTAKE	2	
17		296262503	TUBE - INTAKE EXTENSION	1	
18		93393001	FITTING-1/8"X90 DEG.ELBOW	1	
19		155446001	FITTING - 1/8 SCHD 40 X 8 NIPPLE	1	
20		296256686	INDICATOR - SERVICE	1	
21		510315411	NUT-HEXFLGL-.38-16-GR2-YZ	4	

Engine Bay Assy Fig 3-12r01

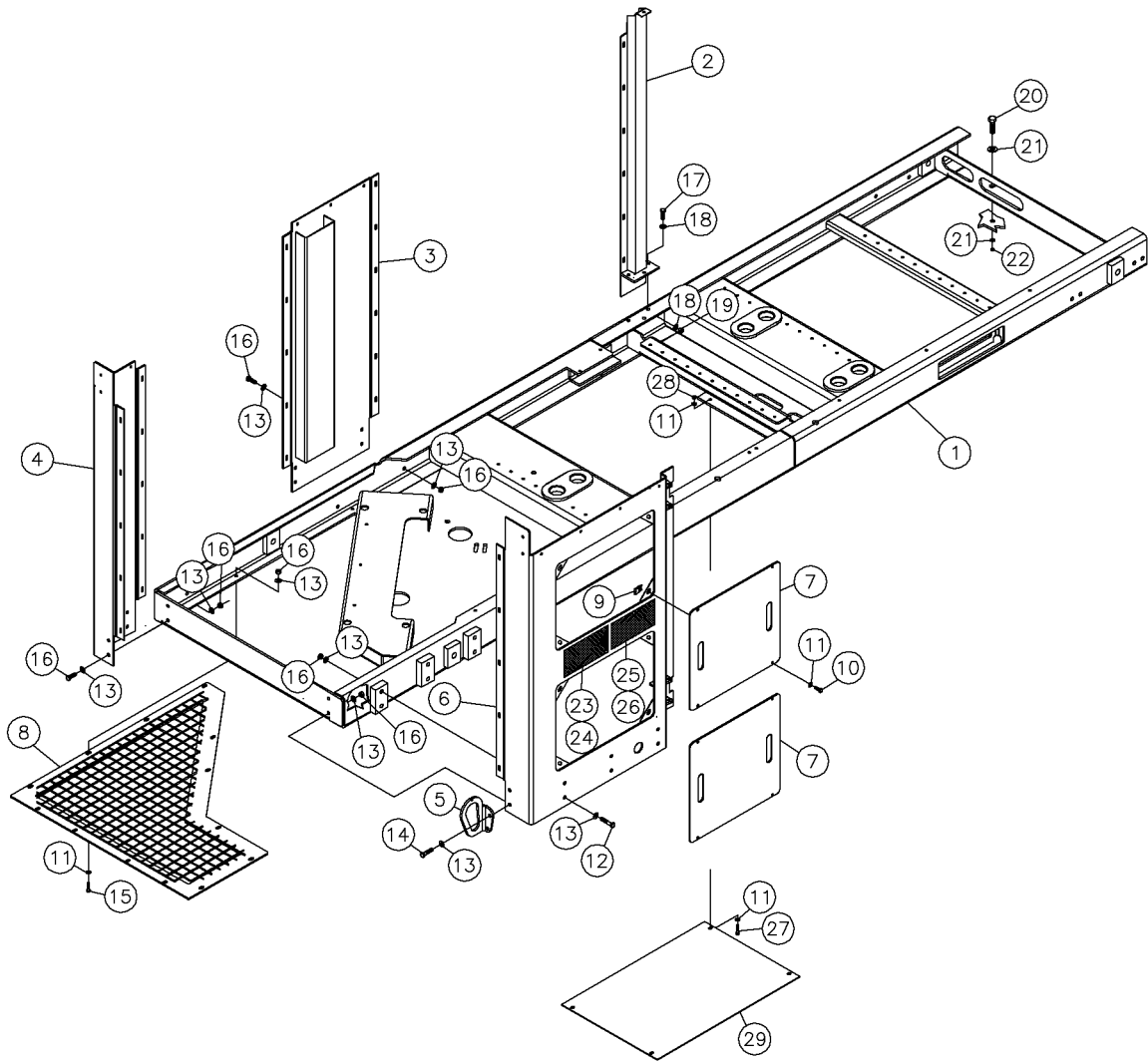

Engine Bay Assy Fig 3-12r01

REF. NO.	*	PART NO.	DESCRIPTION	QTY.	REMARKS
		Revision Date	June, 2002		Updated Drawing
1	*	296256333	FRAME ENGINE BAY	1	
2		288843001	UPRIGHT PANEL MOUNT	1	
3		296256364	PLATE- ENGINE BASE WELDMENT	1	
4		296256325	PLATE - LR ENGINE BAY UPRIGHT	1	
5		296256476	PLATE - CRANE HOOK	1	
6		296256367	UPRIGHT ENGINE BAY	1	
7		296256366	PLATE - ACCESS PANEL	1	
8		296256387	GRILLE - BOTTOM	1	
9		13323001	U-CLIP - 3/8-16	8	
10		235727001	BOLT-3/8-16X1 GR8 HEX ZINC PLT	8	
11	*	235713001	WASHER-3/8 SAE HARD ZINC PLTD	42	
12		279269001	BOLT-1/2-20X2 1/2 HCS GR8 Y/ZN	6	
13		235712001	WASHER-1/2 SAE HARD ZINC PLTD	32	
14		235718001	BOLT-1/2-13X2 GR8 HEX ZINC PLT	2	
15		235723001	BOLT-3/8-16X1 1/2 GR8 ZINC PLT	13	
16		485025	WASHER-1/2 FLAT-HARDENED-ZINC	16	
17		250506001	BOLT 7/16-14 X 1 1/2" GR8 HEX	3	
18		510337609	WASHER-FLATSTD-.44-.50X1.25-.08-YZ	6	
19		250509001	NUT-7/16-NC GR8 TOP LOCK Y/ZI	3	
20		238880001	BOLT-3/4-10X2 1/2 HHCS GR8 ZY	14	
21		235717001	WASHER-3/4 FLAT HARDENED YELLOW ZINC	28	
22		235739001	NUT-3/4-10 GR8 ZINC PLTD	14	
23		7000B617	DECAL - DANGER POWER LINES	1	
24		700IB617	DECAL - DANGER POWER LINES	1	International
25		7000B623	DECAL - DANGER ELECTRIC SHOCK	1	
26		700IB623	DECAL - DANGER ELECTRIC SHOCK	1	International
27	*	235736001	BOLT-3/8-16X1 1/4 ZINC PLTD	4	
28	*	235725001	NUT - HEX - .38 - 16 - GR8 - YZ	4	
29	*	296257386	SHIELD - ENGINE BAY TRACK	1	

Engine Bay Assy Fig 3-12

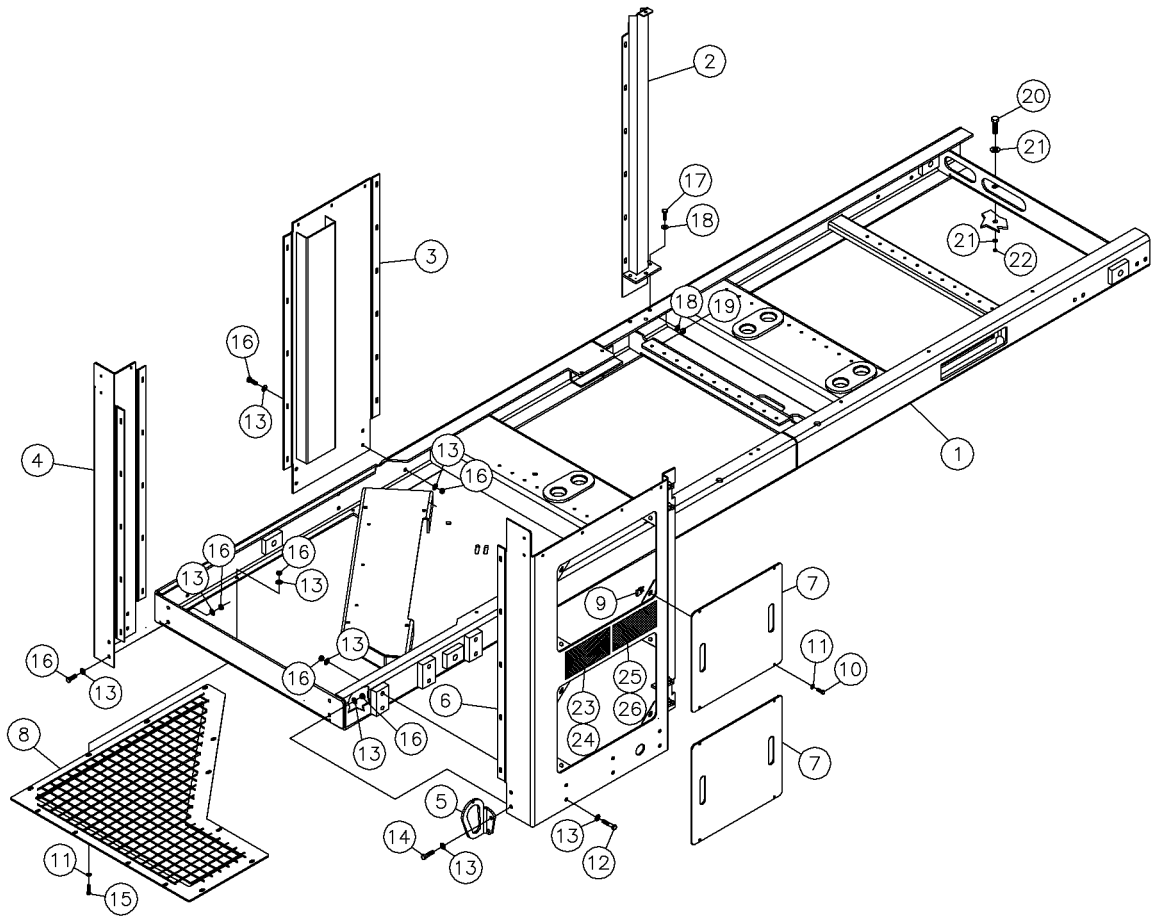

Engine Bay Assy Fig 3-12

REF. NO.	*	PART NO.	DESCRIPTION	QTY.	REMARKS
1		296256333	FRAME ENGINE BAY	1	
2		288843001	UPRIGHT PANEL MOUNT	1	
3		296256364	PLATE- ENGINE BASE WELDMENT	1	
4		296256325	PLATE - LR ENGINE BAY UPRIGHT	1	
5		296256476	PLATE - CRANE HOOK	1	
6		296256367	UPRIGHT ENGINE BAY	1	
7		296256366	PLATE - ACCESS PANEL	1	
8		296256387	GRILLE - BOTTOM	1	
9		13323001	U-CLIP - 3/8-16	8	
10		235727001	BOLT-3/8-16X1 GR8 HEX ZINC PLT	8	
11		235713001	WASHER-3/8 SAE HARD ZINC PLTD	34	
12		279269001	BOLT-1/2-20X2 1/2 HCS GR8 Y/ZN	6	
13		235712001	WASHER-1/2 SAE HARD ZINC PLTD	32	
14		235718001	BOLT-1/2-13X2 GR8 HEX ZINC PLT	2	
15		235723001	BOLT-3/8-16X1 1/2 GR8 ZINC PLT	13	
16		485025	WASHER-1/2 FLAT-HARDENED-ZINC	16	
17		250506001	BOLT 7/16-14 X 1 1/2" GR8 HEX	3	
18		510337609	WASHER-FLATSTD-.44-.50X1.25-.08-YZ	6	
19		250509001	NUT-7/16-NC GR8 TOP LOCK Y/ZI	3	
20		238880001	BOLT-3/4-10X2 1/2 HHCS GR8 ZY	14	
21		235717001	WASHER-3/4 FLAT HARDENED YELLOW ZINC	28	
22		235739001	NUT-3/4-10 GR8 ZINC PLTD	14	
23		7000B617	DECAL - DANGER POWER LINES	1	
24		700IB617	DECAL - DANGER POWER LINES	1	International
25		7000B623	DECAL - DANGER ELECTRIC SHOCK	1	
26		700IB623	DECAL - DANGER ELECTRIC SHOCK	1	International

Engine Mount Assy Fig 3-13r01

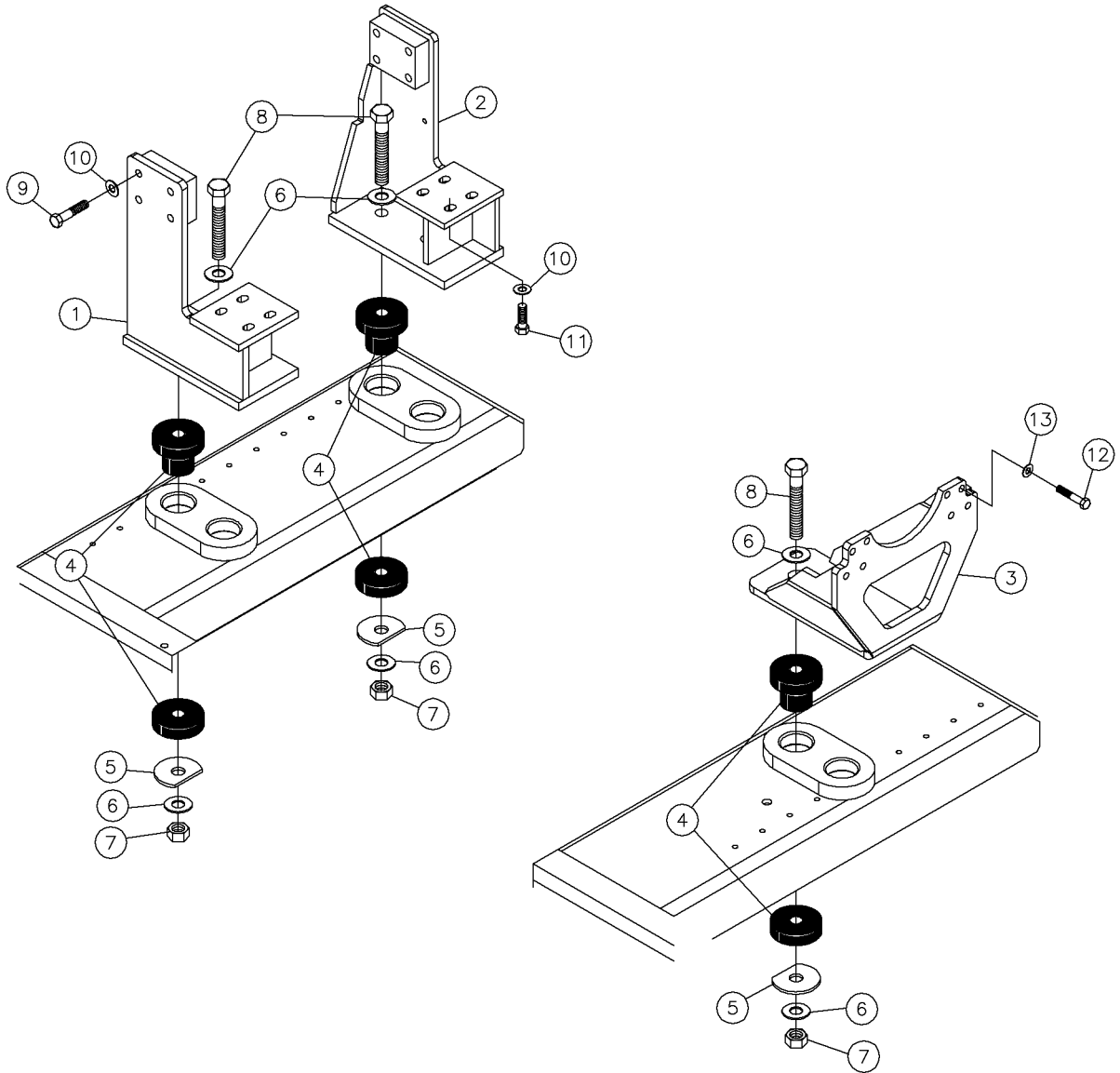

Engine Mount Assy Fig 3-13r01

REF. NO.	*	PART NO.	DESCRIPTION	QTY.	REMARKS
		Revision Date	June, 2002		Update In Illustration.
1		288809001	MOUNT,LH ENGINE, CAT 3196	1	
2		288808001	MOUNT - RH ENGINE CAT 3196	1	
3		288801001	MOUNT ENGINE,3196	1	
4		116813001	MOUNT-MOTOR	6	
5		296256487	WASHER ENGINE MOUNT	3	
6		85759001	WASHER-1"HARDEN ASTM-A325	6	
7		75390001	NUT-1-UNC GR.8 TOP LOCK HEX	6	
8		160767001	BOLT - 1-8 X 6 1/2" HHCS GR 8 ZY	6	
9		145645001	BOLT - 5/8 - 11 X 2 GR.8 PLATED	8	
10		235715001	WASHER-5/8 SAE HARD ZINC PLTD	12	
11		243917001	SCREW- 5/8 - 18 X 3 HEX HEAD CAP ZINC PLATED	4	
12		507407070	SCREW-HCS,M12-1.75X70,10.9,YZ,ISO4017,FT	8	
13		485025	WASHER-1/2 FLAT-HARDENED-ZINC	8	

Engine Mount Assy Fig 3-13

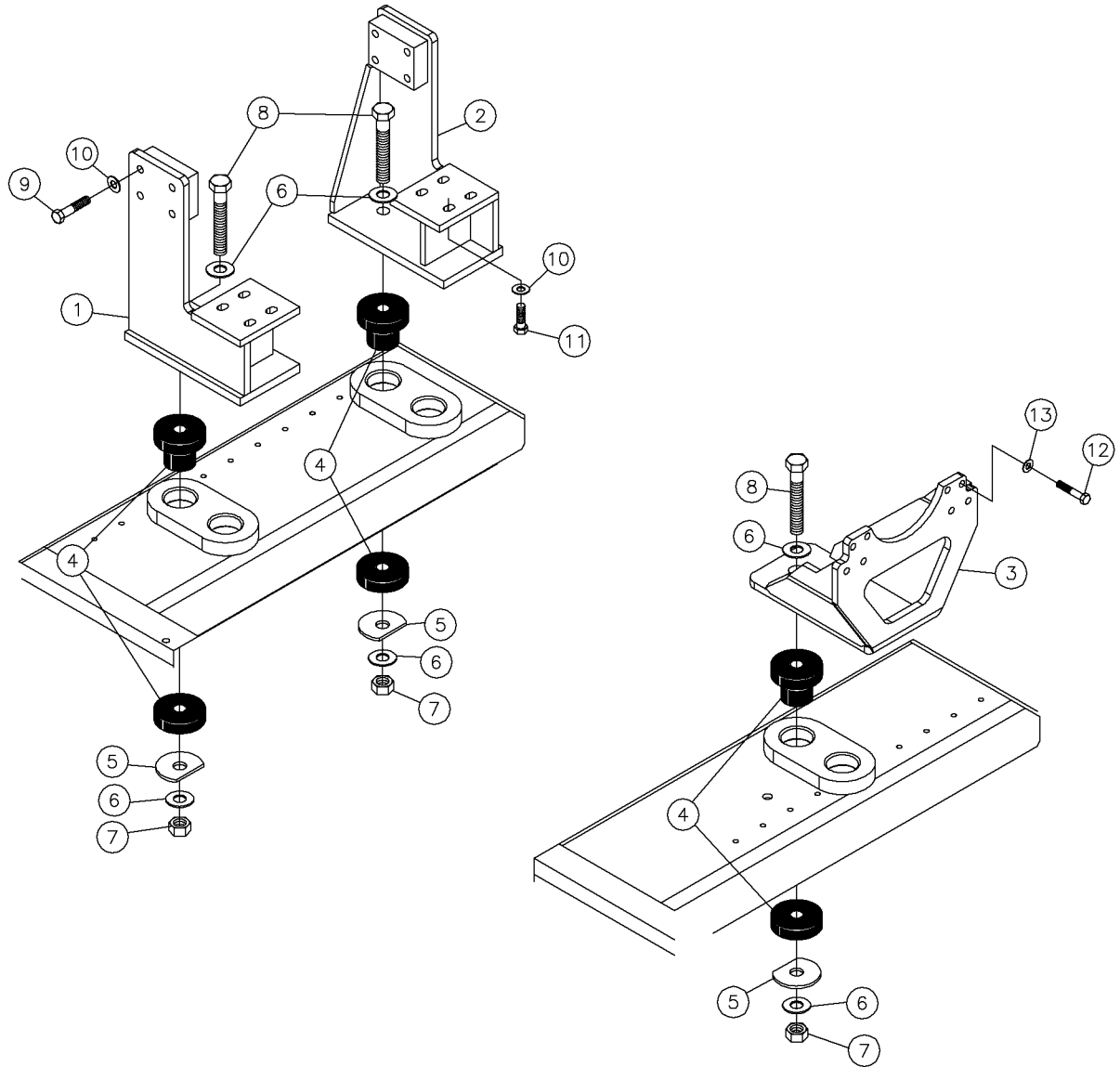

Engine Mount Assy Fig 3-13

REF. NO.	*	PART NO.	DESCRIPTION	QTY.	REMARKS
1		288809001	MOUNT,LH ENGINE, CAT 3196	1	
2		288808001	MOUNT - RH ENGINE CAT 3196	1	
3		288801001	MOUNT ENGINE,3196	1	
4		116813001	MOUNT-MOTOR	6	
5		296256487	WASHER ENGINE MOUNT	3	
6		85759001	WASHER-1"HARDEN ASTM-A325	6	
7		75390001	NUT-1-UNC GR.8 TOP LOCK HEX	6	
8		160767001	BOLT - 1-8 X 6 1/2" HHCS GR 8 ZY	6	
9		145645001	BOLT - 5/8 - 11 X 2 GR.8 PLATED	8	
10		235715001	WASHER-5/8 SAE HARD ZINC PLTD	12	
11		243917001	SCREW- 5/8 - 18 X 3 HEX HEAD CAP ZINC PLATED	4	
12		507407070	SCREW-HCS,M12-1.75X70,10.9,YZ,ISO4017,FT	8	
13		485025	WASHER-1/2 FLAT-HARDENED-ZINC	8	

Engine - Expansion Tank Assy Fig 3-14r01

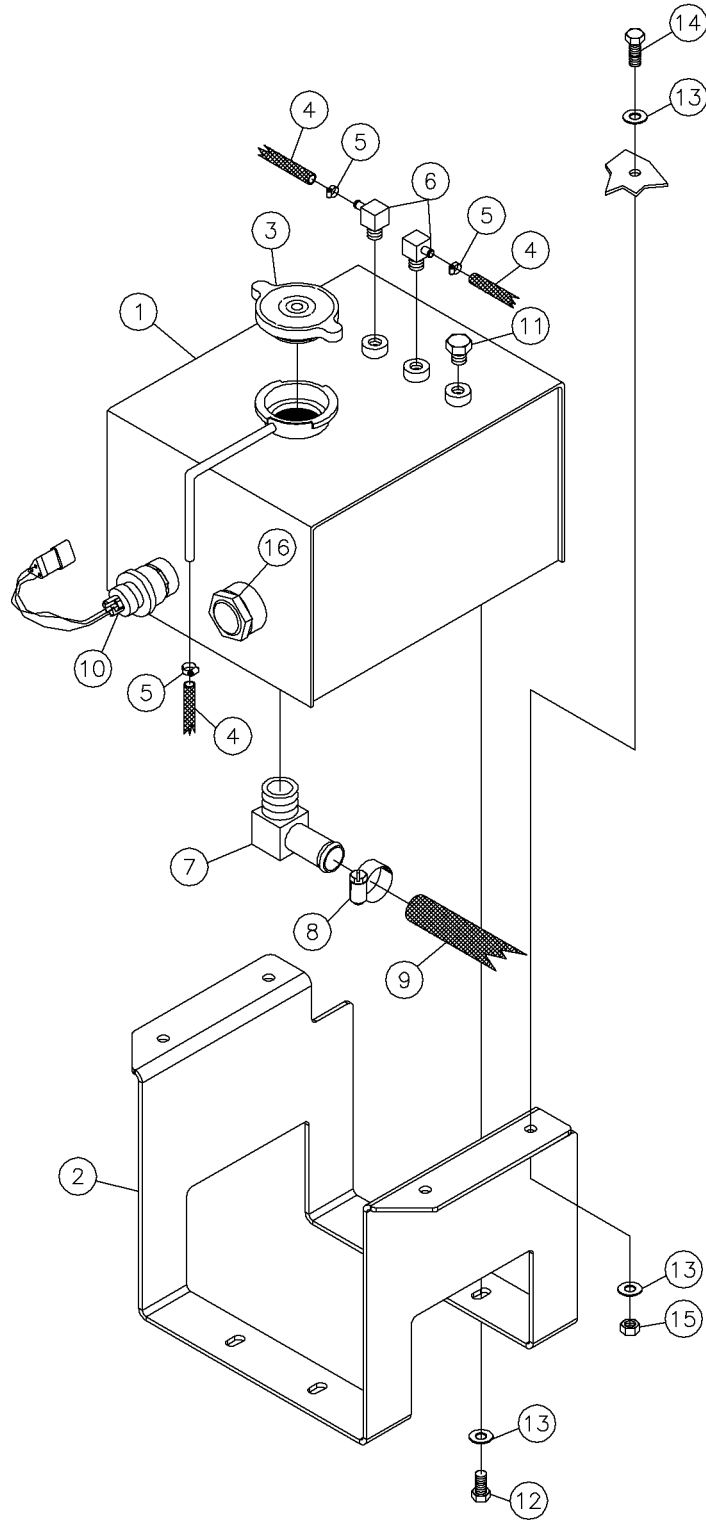

Engine - Expansion Tank Assy Fig 3-14r01

REF. NO.	*	PART NO.	DESCRIPTION	QTY.	REMARKS
		Revision Date	October, 2004		Update In Parts List.
1		296263286	TANK AS-EXP	1	
2		293716001	PLATE - SURGE TANK MOUNT	1	
3		296263287	CAP PRESSURE	1	
4		620001	HOSE - 5/16 FUEL LINE	A/R	Specify Length
5		1580001	HOSE CLAMP - 3/8" REF T11965	3	
6		83124001	FITTING- #1556 WTHR-HD	2	
7		901888001	1 X 3/4 90 INSERT	1	
8		1580007	HOSE CLAMP - 1 1/2" REF T08517	1	
9		296262540	HOSE - HEAT - 1.0 X 72	A/R	Specify Length
10		296263288	COOLANT LEVEL SENSOR	1	
11		504607001	PIPE PLUG-1/8 HEX HEAD STEEL	1	
12		235726001	BOLT-3/8-16X3/4 GR8 HEX ZNCPLT	4	
13		235713001	WASHER - FLATSTRL - .38 - .41 X .81 - .06-YA-A325	12	
14		235727001	BOLT-3/8-16X1 GR8 HEX ZINC PLT	4	
15		235725001	NUT - HEX - .38 - 16 - GR8 - YZ	4	
16		296263289	BODY AS-GAGE	1	

Engine - Expansion Tank Assy Fig 3-14

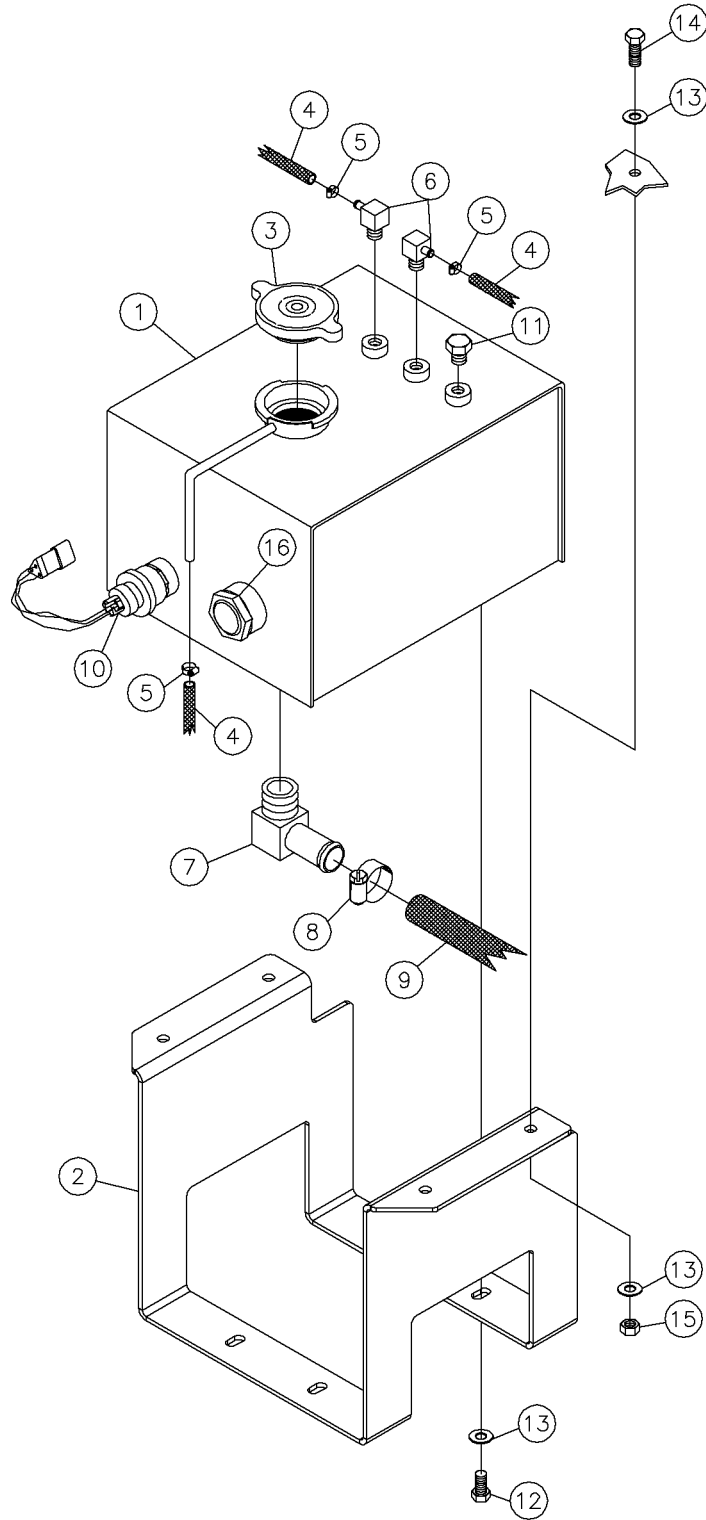

Engine - Expansion Tank Assy Fig 3-14

REF. NO.	*	PART NO.	DESCRIPTION	QTY.	REMARKS
1		296263286	TANK AS-EXP	1	
2		293716001	PLATE - SURGE TANK MOUNT	1	
3		296263287	CAP PRESSURE	1	
4		620001	HOSE - 5/16 FUEL LINE	A/R	P/N Qty Of 1 = 1 Foot
5		1580001	HOSE CLAMP - 3/8"	3	
6		83124001	FITTING- #1556 WTHR-HD	2	
7		901888001	FITTING 1 X 3/4 90 INSERT	1	
8		1580007	HOSE CLAMP - 1 1/2"	1	
9		296262540	HOSE - HEAT - 1.0 X 72	A/R	
10		296263288	COOLANT LEVEL SENSOR	1	
11		504607001	PIPE PLUG-1/8 HEX HEAD STEEL	1	
12		235726001	BOLT-3/8-16X3/4 GR8 HEX ZNCPLT	4	
13		235713001	WASHER-3/8 SAE HARD ZINC PLTD	12	
14		235727001	BOLT-3/8-16X1 GR8 HEX ZINC PLT	4	
15		235725001	NUT-3/8-16 GR8 ZINC PLTD	4	
16		296263289	BODY AS-GAGE	1	

Engine - Fuel Tank Assy Fig 3-15r01

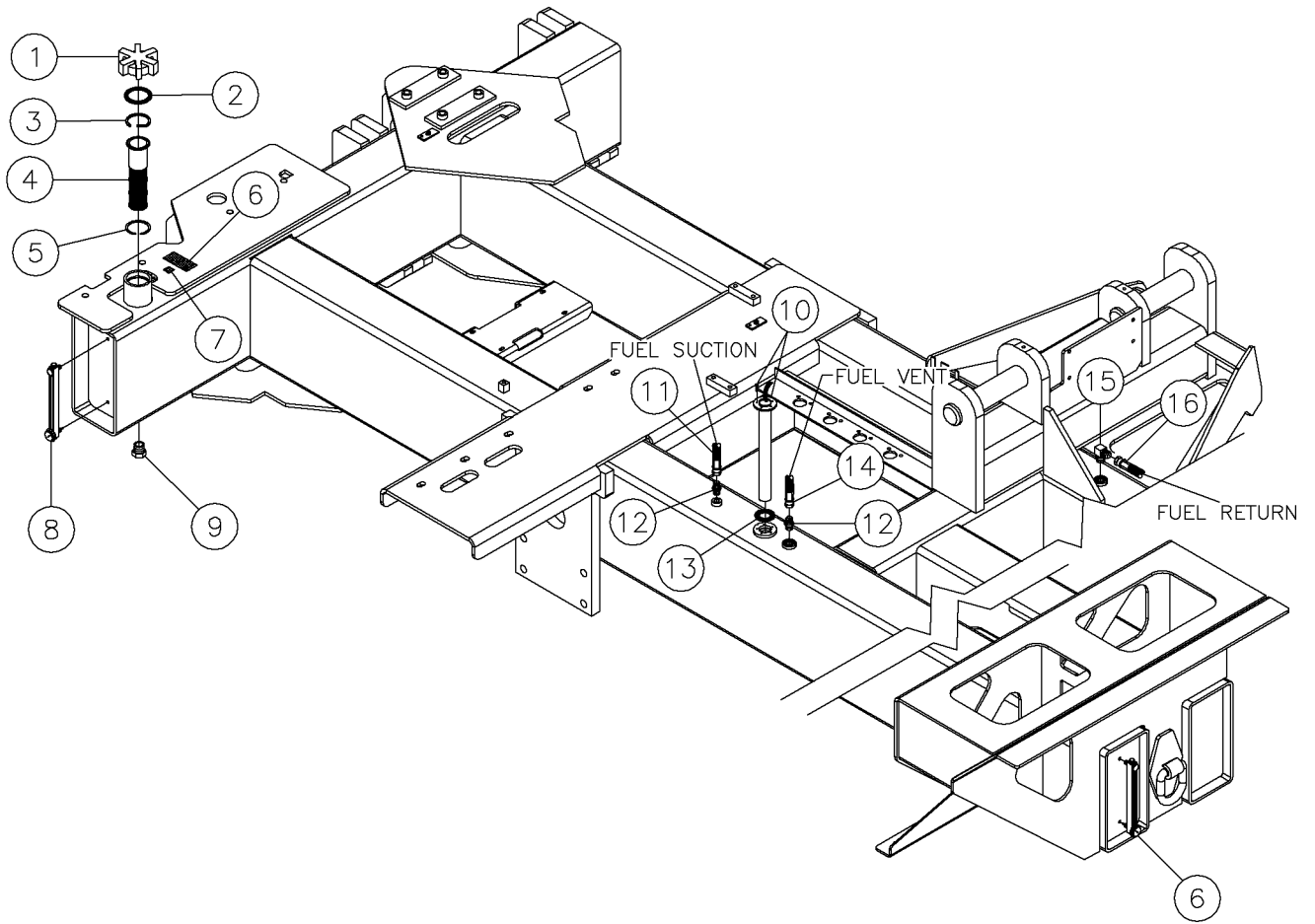

Engine - Fuel Tank Assy Fig 3-15r01

REF. NO.	*	PART NO.	DESCRIPTION	QTY.	REMARKS
		Revision Date	October, 2004		Update In Illustration & Parts List.
1		106851001	CAP-FUEL	1	
2		111468001	GASKET	1	
3		111472001	SNAP RING-INTERNAL	1	
4		111467001	STRAINER-FUEL GET FROM TRACK DIV.	1	
5		111471001	SNAP RING-INTERNAL	1	
6		2326324	DECAL-WARNING/REFUEL	1	Domestic
		23261324	DECAL - WARNING EXPLOSION	1	International
7		70000098	DECAL-DIESEL (AT/UND)	1	Domestic
		70001098	DECAL-DIESEL FUEL	1	International
8		113092001	GAUGE-10" LIQUID LEVEL	2	
9		73065001	FITTING-24M PLUG	1	
10		283058001	SWITCH- FUEL LEVEL	1	
11		296258479	HOSE - FUEL - 10 X 74 10FS JIC ST/ST 500 PSI	1	
12		67850001	8M X 10MJIC STR	2	
13		251538001	SENDER - FUEL LEVEL	1	
14		296256862	HOSE - FUEL - 10 X 60 10FS JIC ST/ST 500 PSI	1	
15		53829001	#10M O-RING-#10M JIC 90 DEG.	1	
16		296258478	HOSE - FUEL - 10 X132 10FS JIC ST/ST 500 PSI	1	

Engine - Fuel Tank Assy Fig 3-15

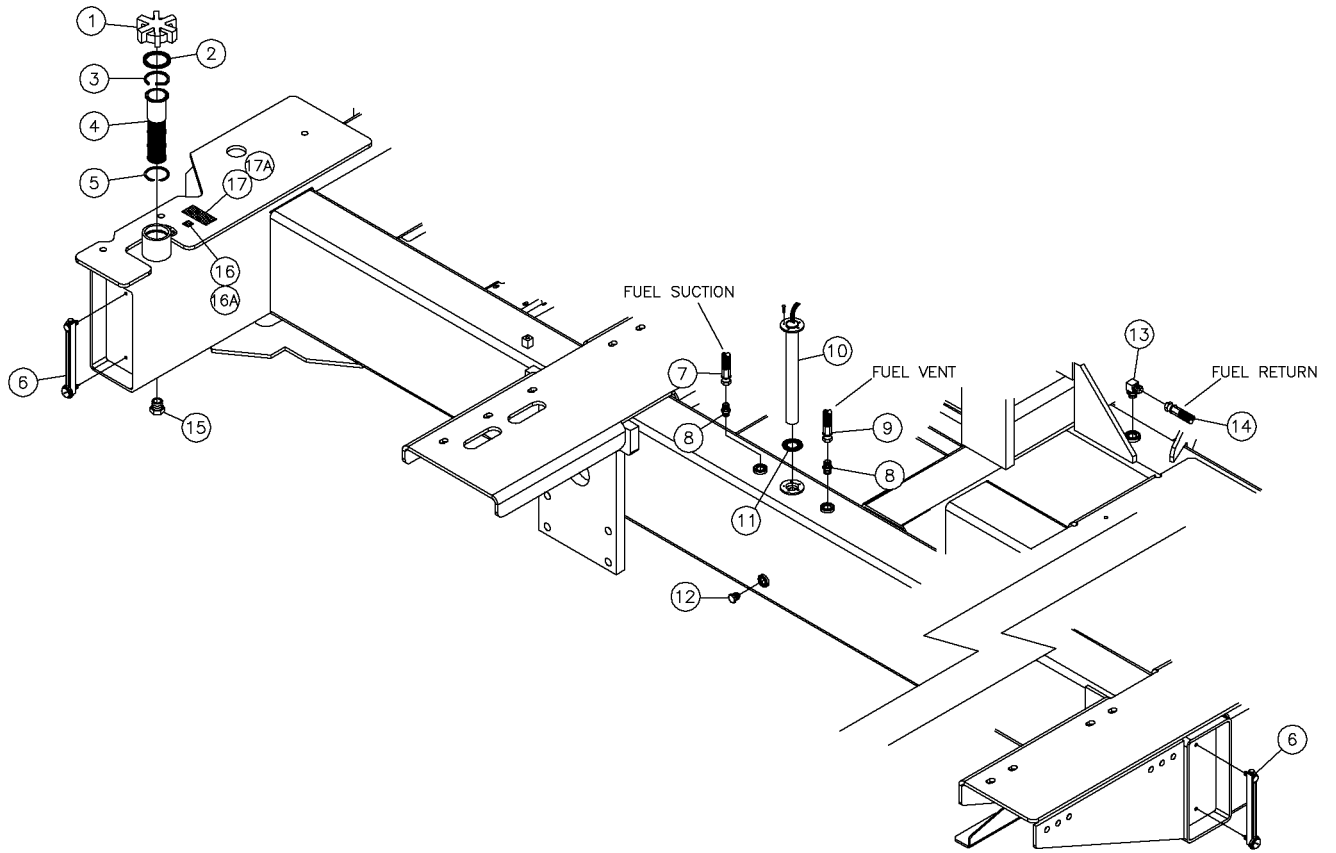

Engine - Fuel Tank Assy Fig 3-15

REF. NO.	*	PART NO.	DESCRIPTION	QTY.	REMARKS
1		106851001	CAP-FUEL	1	
2		111468001	GASKET	1	
3		111472001	SNAP RING-INTERNAL	1	
4		111467001	STRAINER-FUEL	1	
5		111471001	SNAP RING-INTERNAL	1	
6		113092001	GAUGE-10" LIQUID LEVEL	2	
7		296258479	HOSE - FUEL - 10 X 74 10FS JIC ST/ST 500 PSI	1	
8		67850001	8M X 10MJIC STR	2	
9		296256862	HOSE - FUEL - 10 X 60 10FS JIC ST/ST 500 PSI	1	
10		283058001	SENSOR- FUEL LEVEL	1	
11		251538001	SENDER - FUEL LEVEL	1	
12		4235001	FITTING-PLUG-10MORB-HEX	1	
13		53829001	#10M O-RING-#10M JIC 90 DEG.	1	
14		296258478	HOSE - FUEL - 10 X132 10FS JIC ST/ST 500 PSI	1	
15		73065001	FITTING-24M PLUG	1	
16		70000098	DECAL-DIESEL (AT/UND)	1	
16A		7000I098	DECAL-DIESEL FUEL	1	International
17		2326324	DECAL-WARNING/REFUEL	1	
17A		2326I324	DECAL-WARNING	1	International

Engine - Fuel Vent Assy Fig 3-16

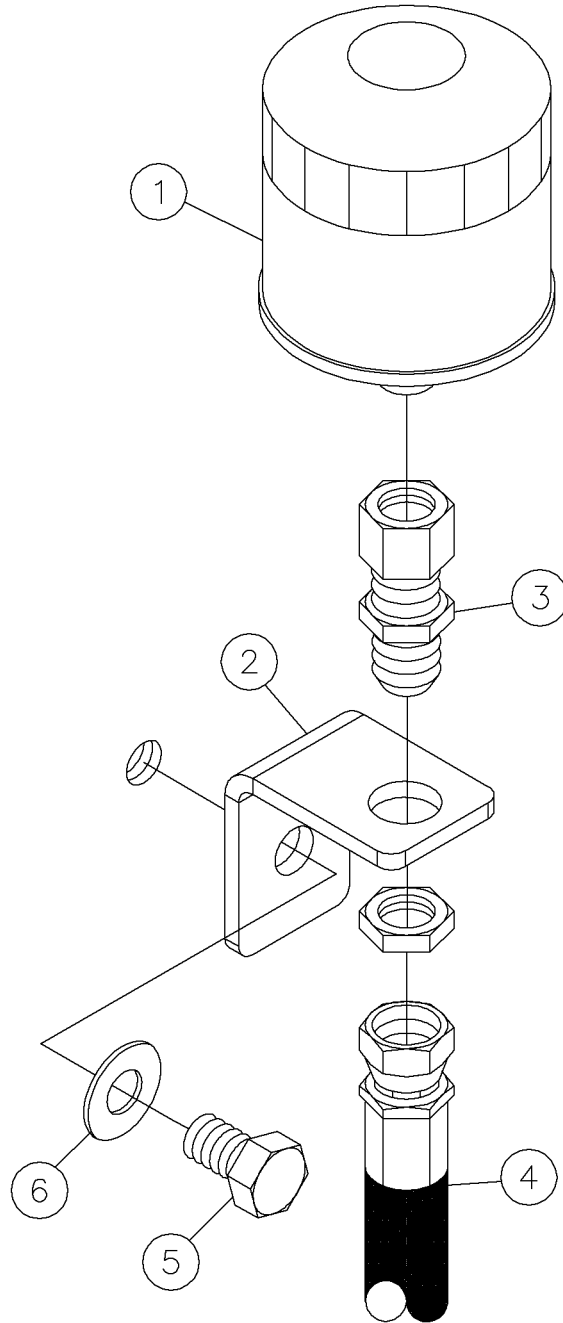

Engine - Fuel Vent Assy Fig 3-16

REF. NO.	*	PART NO.	DESCRIPTION	QTY.	REMARKS
1		108475001	FILTER-BREATHER1/2NPTW/ORELIEF	1	
2		296256443	BRACKET - FUEL TANK MOUNT	1	
3		296256459	FITTING - BHSTR 10MJ - 8FNPT	1	
4		296256862	HOSE - FUEL - 10 X 60 10FS JIC ST/ST 500 PSI	1	
5		244211001	BOLT-5/8-11X1 GR8 HEX ZINC PLTD	1	
6		235715001	WASHER-5/8 SAE HARD ZINC PLTD	1	

Shield-Engine Side Assy Fig 4-1r01

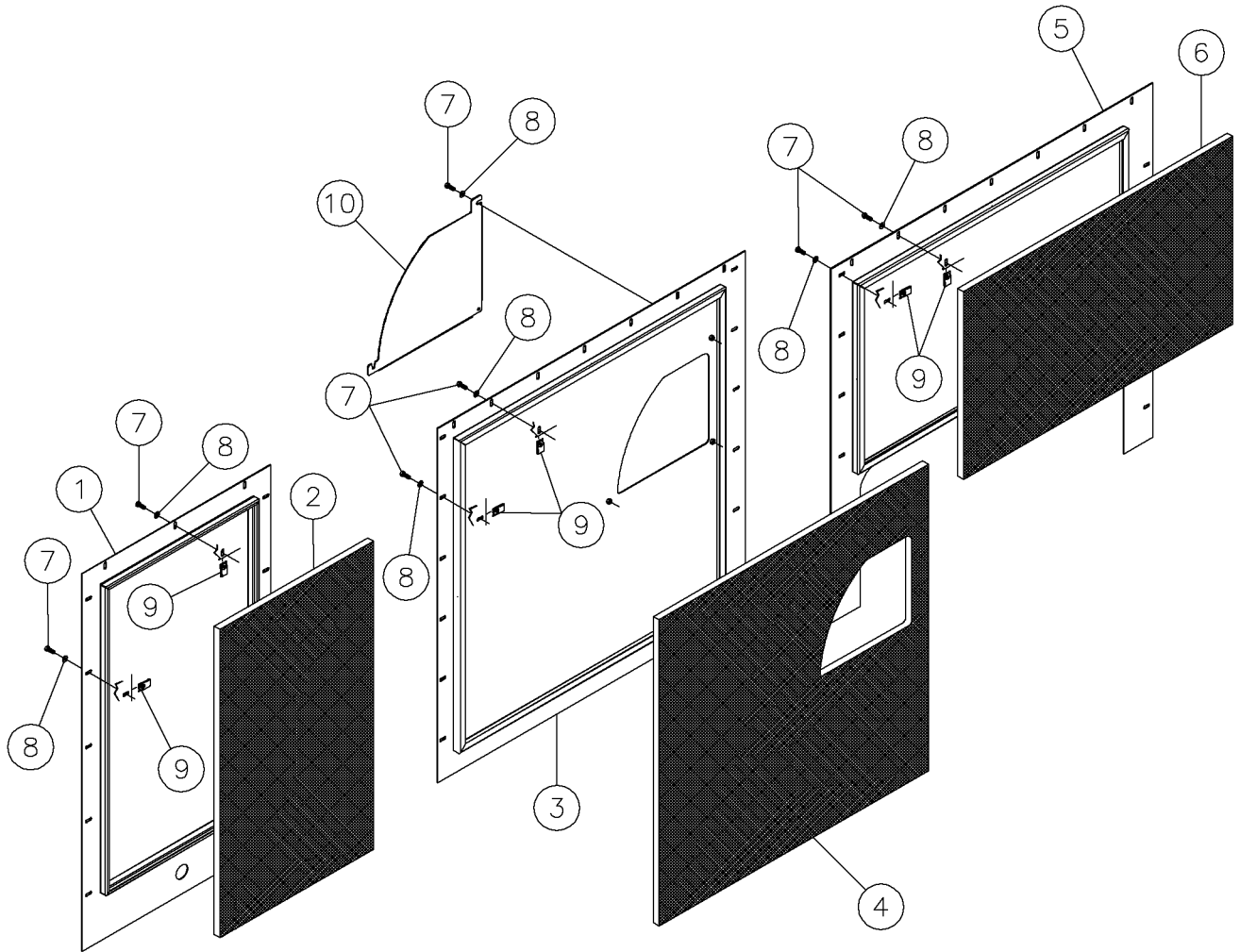

Shield-Engine Side Assy Fig 4-1r01

REF. NO.	*	PART NO.	DESCRIPTION	QTY.	REMARKS
		Revision Date	October, 2004		Update In Illustration.
1		296256358	SHIELD - LEFT REAR ENGINE BAY	1	
2		296262604	FOAM - LEFT FRONT	1	
3		288966001	SHIELD - LEFT CENTER ENGINE BAY	1	
4		296262606	FOAM - LEFT CENTER	1	
5		288965001	SHIELD - LEFT FRONT ENGINE BAY	1	
6		296256436	FOAM - LEFT REAR	1	
7		235727001	BOLT-3/8-16X1 GR8 HEX ZINC PLT	52	
8		235713001	WASHER - FLATSTRL - .38 - .41 X .81 - .06-YA-A325	52	
9		13323001	NUT - PANEL - 3/8-16 U-CLIP	49	
10		288964001	PLATE - FRONT COVER	1	

Shield-Engine Side Assy Fig 4-1

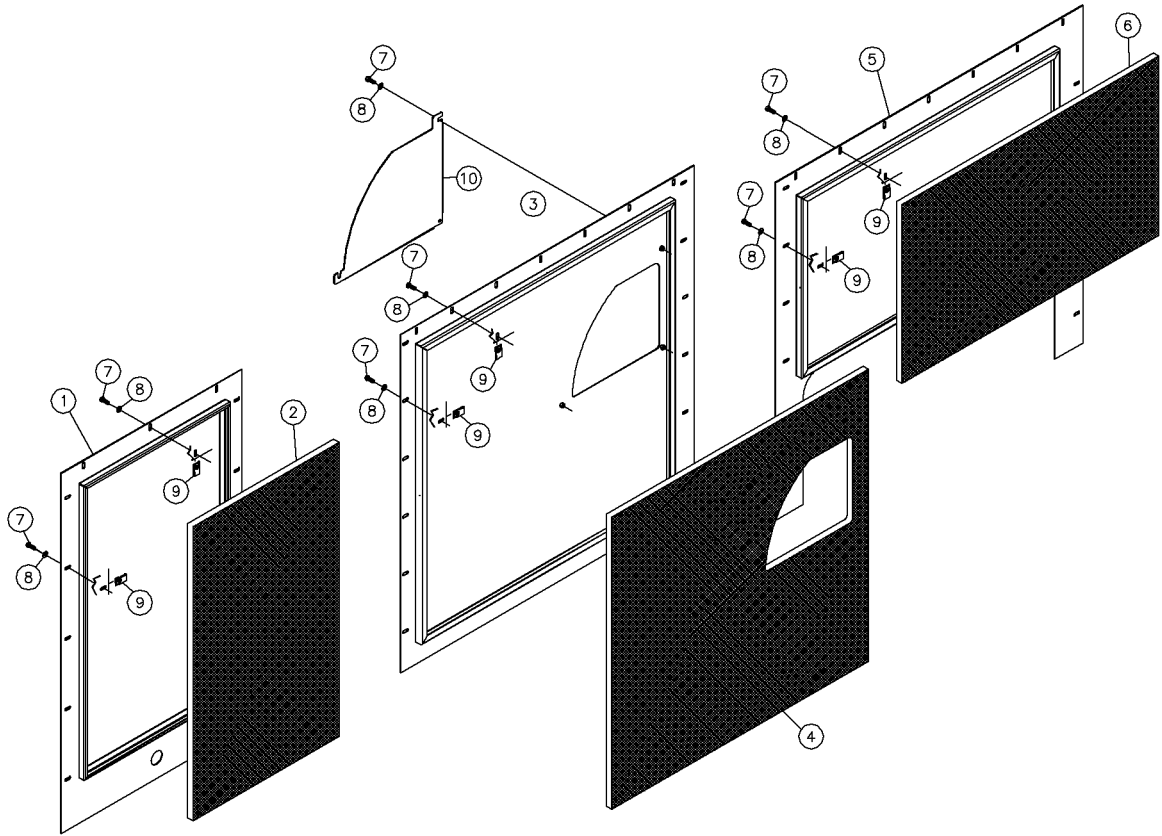

Shield-Engine Side Assy Fig 4-1

REF. NO.	*	PART NO.	DESCRIPTION	QTY.	REMARKS
1		296256358	SHIELD - LEFT REAR ENGINE BAY	1	
2		296262604	FOAM - LEFT FRONT	1	
3		288966001	SHIELD - LEFT CENTER ENGINE BAY	1	
4		296262606	FOAM - LEFT CENTER	1	
5		288965001	SHIELD - LEFT FRONT ENGINE BAY	1	
6		296256436	FOAM - LEFT REAR	1	
7		235727001	BOLT-3/8-16X1 GR8 HEX ZINC PLT	52	
8		235713001	WASHER-3/8 SAE HARD ZINC PLTD	52	
9		13323001	U-CLIP - 3/8-16	49	
10		288964001	PLATE - FRONT COVER	1	

Shield-Radiator Top Assy Fig 4-2r02

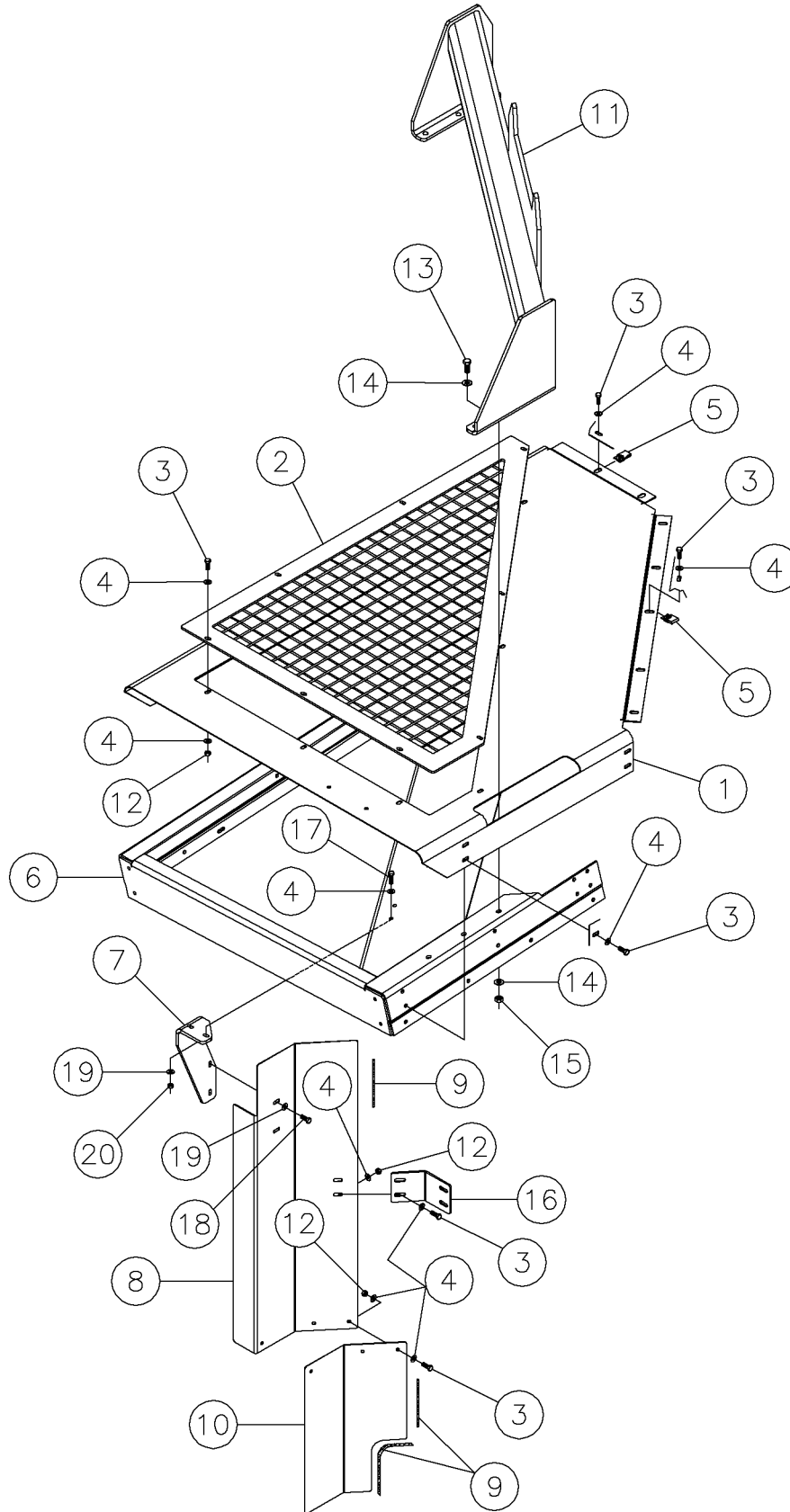

Shield-Radiator Top Assy Fig 4-2r02

REF. NO.	*	PART NO.	DESCRIPTION	QTY.	REMARKS
		Revision Date	October, 2004		Update In Illustration.
1		296256356	SHIELD - TOP REAR	1	
2		296256385	GRILLE - TOP	1	
3		235727001	BOLT-3/8-16X1 GR8 HEX ZINC PLT	21	
4		235713001	WASHER - FLATSTRL - .38 - .41 X .81 - .06-YA-A325	53	
5		13323001	NUT - PANEL - 3/8-16 U-CLIP	7	
6		296256329	FRAME - RADIATOR MOUNT	1	
7		296256468	ANGLE - RADIATOR MOUNT	1	
8		296256477	PLATE - UPPER AIR DAM	1	
9		212522001	TRIM-1/4 EDGE	A/R	Specify Length
10		296256478	PLATE - LOWER AIR DAM	1	
11		293726001	SADDLE CRANE	1	
12		235725001	NUT - HEX - .38 - 16 - GR8 - YZ	25	
13		235737001	BOLT-1/2-13X1 1/4 GR8 ZINC PLT	6	
14		485025	WASHER-1/2 FLAT-HARDENED-YZ	12	
15		235731001	NUT-1/2-13 GR8 ZINC PLTD	8	
16		296262539	BRACKET - AIR DAM	1	
17		235736001	BOLT-3/8-16X1 1/4 ZINC PLTD	2	
18		238209001	BOLT-5/16-18X1 GR8 HEX ZINC YC	2	
19		235714001	WASHER - FLATSTRL - .31 - .34 X .69 - .06-YZ-A325	4	
20		235741001	NUT - HEX - .31 - 18 - GR8 -YZ	2	

Shield-Radiator Top Assy Fig 4-2r01

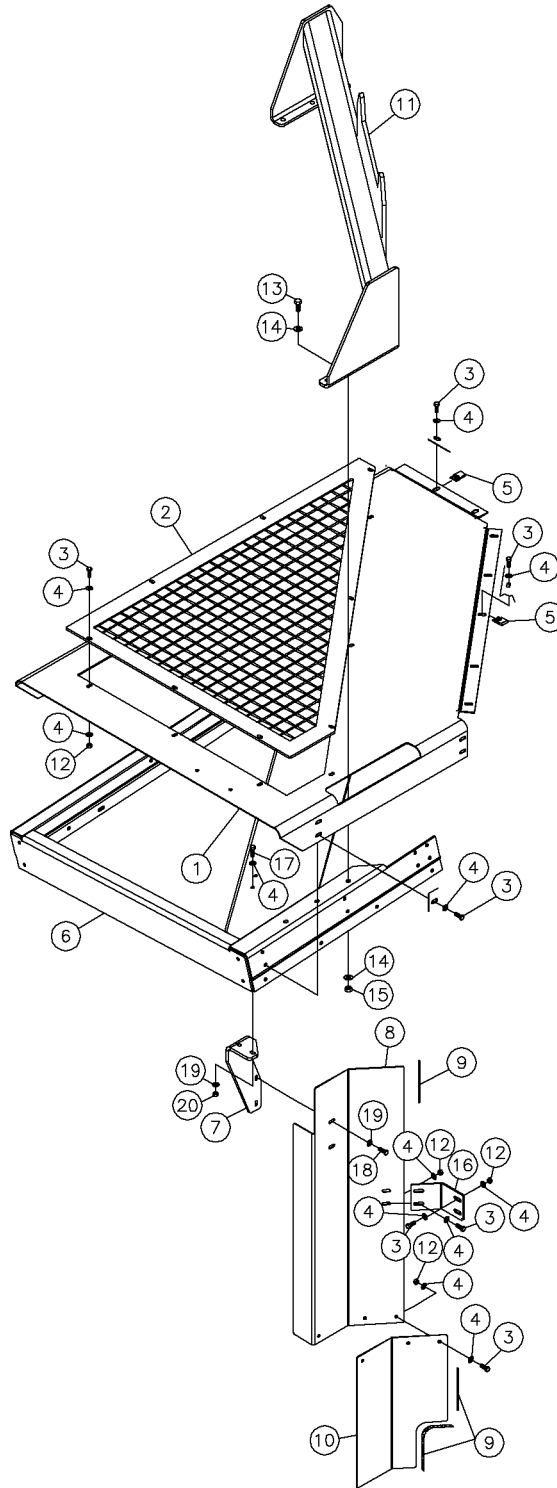

Shield-Radiator Top Assy Fig 4-2r01

REF. NO.	*	PART NO.	DESCRIPTION	QTY.	REMARKS
		Revision Date	June, 2002		Update In Illustration.
1		296256356	SHIELD - TOP REAR	1	
2		296256385	GRILLE - TOP	1	
3		235727001	BOLT-3/8-16X1 GR8 HEX ZINC PLT	21	
4		235713001	WASHER-3/8 SAE HARD ZINC PLTD	53	
5		13323001	U-CLIP - 3/8-16	7	
6		296256329	FRAME - RADIATOR MOUNT	1	
7		296256468	ANGLE - RADIATOR MOUNT	1	
8		296256477	PLATE - UPPER AIR DAM	1	
9		212522001	TRIM-1/4 EDGE	A/R	P/N Qty Of 1 = 1 Foot
10		296256478	PLATE - LOWER AIR DAM	1	
11		293726001	SADDLE CRANE	1	
12		235725001	NUT-3/8-16 GR8 ZINC PLTD	25	
13		235737001	BOLT-1/2-13X1 1/4 GR8 ZINC PLT	6	
14		485025	WASHER-1/2 FLAT-HARDENED-ZINC	12	
15		235731001	NUT-1/2-13 GR8 ZINC PLTD	8	
16		296262539	BRACKET - AIR DAM	1	
17		235736001	BOLT-3/8-16X1 1/4 ZINC PLTD	2	
18		238209001	BOLT-5/16-18X1 GR8 NEX ZINC YC	2	
19		235714001	WASHER-5/16 SAE HARD ZINC PLTD	4	
20		235741001	NUT-5/16-18 GR8 ZINC PLTD	2	

Shield-Radiator Top Assy Fig 4-2

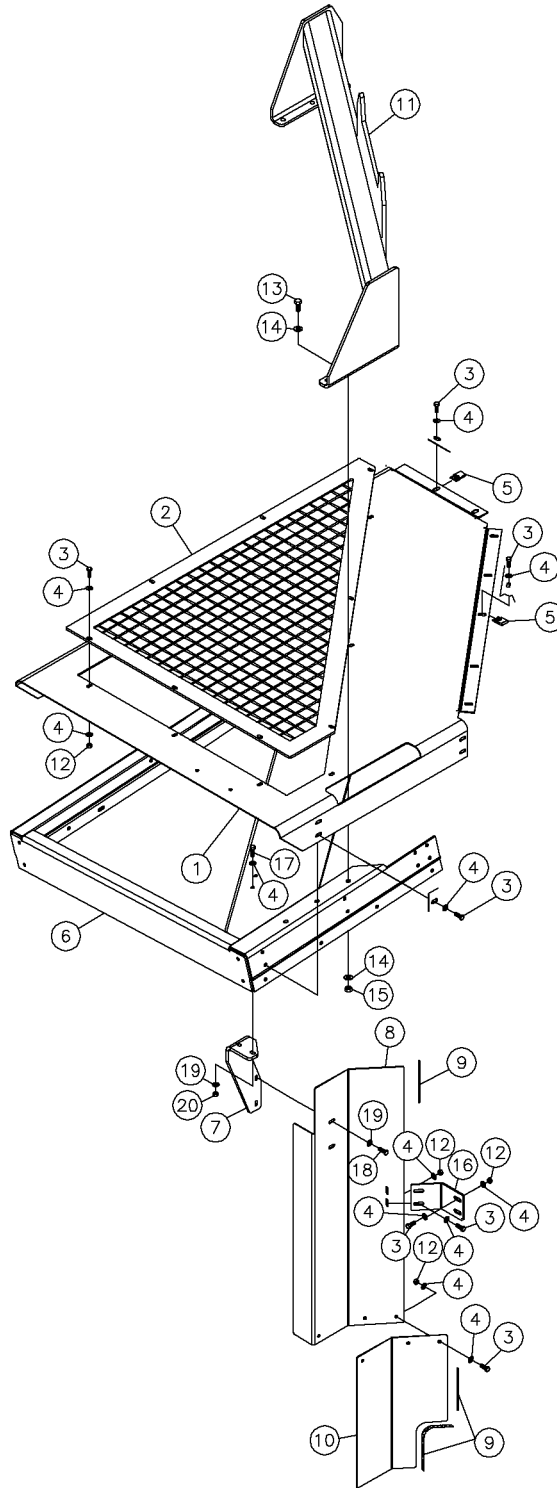

Shield-Radiator Top Assy Fig 4-2

REF. NO.	*	PART NO.	DESCRIPTION	QTY.	REMARKS
1		296256356	SHIELD - TOP REAR	1	
2		296256385	GRILLE - TOP	1	
3		235727001	BOLT-3/8-16X1 GR8 HEX ZINC PLT	21	
4		235713001	WASHER-3/8 SAE HARD ZINC PLTD	53	
5		13323001	U-CLIP - 3/8-16	7	
6		296256329	FRAME - RADIATOR MOUNT	1	
7		296256468	ANGLE - RADIATOR MOUNT	1	
8		296256477	PLATE - UPPER AIR DAM	1	
9		212522001	TRIM-1/4 EDGE	A/R	P/N Qty Of 1 = 1 Foot
10		296256478	PLATE - LOWER AIR DAM	1	
11		293726001	SADDLE CRANE	1	
12		235725001	NUT-3/8-16 GR8 ZINC PLTD	25	
13		235737001	BOLT-1/2-13X1 1/4 GR8 ZINC PLT	6	
14		485025	WASHER-1/2 FLAT-HARDENED-ZINC	12	
15		235731001	NUT-1/2-13 GR8 ZINC PLTD	8	
16		296262539	BRACKET - AIR DAM	1	
17		235736001	BOLT-3/8-16X1 1/4 ZINC PLTD	2	
18		238209001	BOLT-5/16-18X1 GR8 NEX ZINC YC	2	
19		235714001	WASHER-5/16 SAE HARD ZINC PLTD	4	
20		235741001	NUT-5/16-18 GR8 ZINC PLTD	2	

Shield-Top Rear Engine Bay Assy Fig 4-3r01

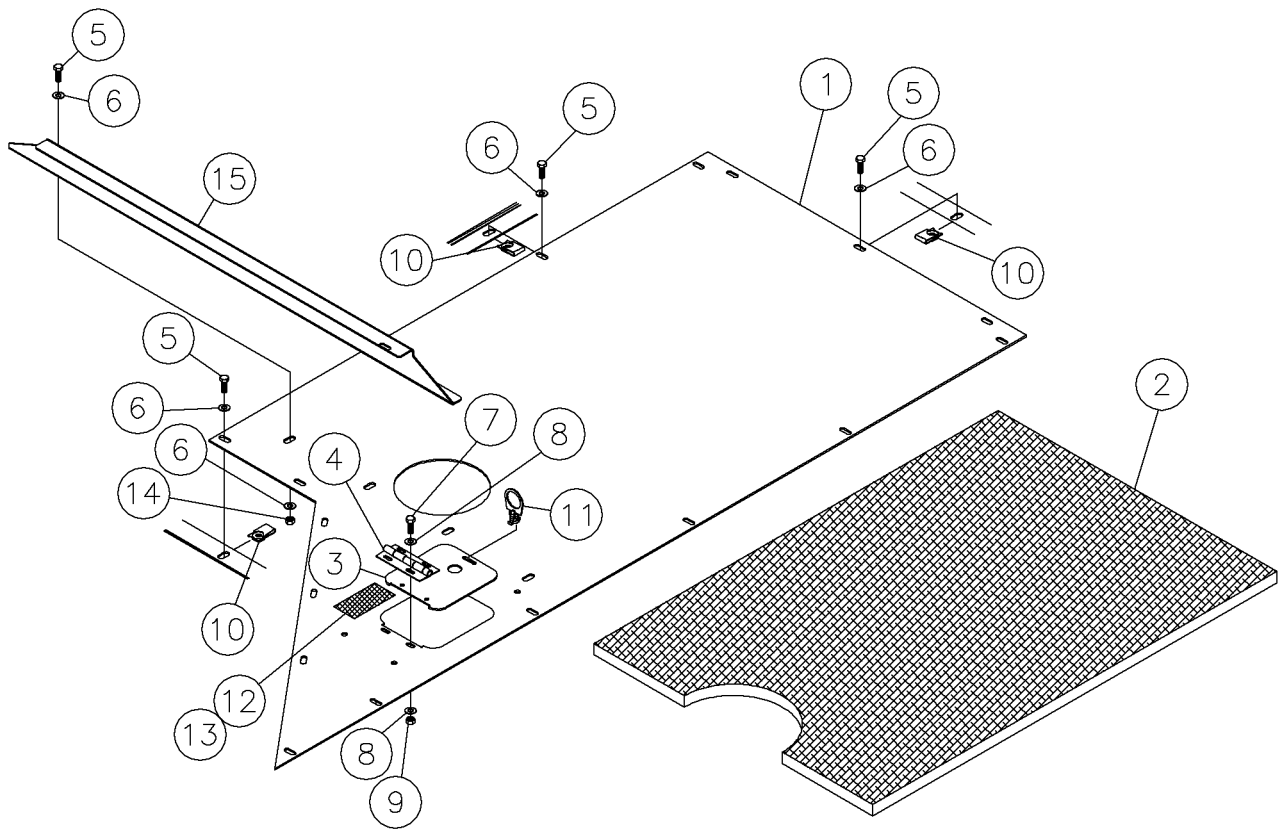

Shield-Top Rear Engine Bay Assy Fig 4-3r01

REF. NO.	*	PART NO.	DESCRIPTION	QTY.	REMARKS
		Revision Date	October, 2004		Update In Illustration & Parts List.
1		293721001	SHIELD - TOP REAR ENGINE BAY	1	
2		296262607	FOAM - TOP REAR	1	
3		296256485	COVER - RADIATOR FILL	1	
4		293717001	HINGE - RADIATOR COVER	1	
5		235727001	BOLT-3/8-16X1 GR8 HEX ZINC PLT	23	
6		235713001	WASHER - FLATSTRL - .38 - .41 X .81 - .06-YA-A325	29	
7		235742001	BOLT-5/16-18X3/4 GR8 ZINC PLTD	4	
8		235714001	WASHER - FLATSTRL - .31 - .34 X .69 - .06-YZ-A325	8	
9		235741001	NUT - HEX - .31 - 18 - GR8 -YZ	4	
10		13323001	NUT - PANEL - 3/8-16 U-CLIP	17	
11		86113001	FASTENER-1/4 TURN	1	
12		2326315	DECAL-WARNING	1	Domestic
13		2326I315	DECAL-WARNING	1	International
14		235725001	NUT - HEX - .38 - 16 - GR8 - YZ	6	
15		296275507	BRACE - TOP PANEL	1	

Shield-Top Rear Engine Bay Assy Fig 4-3

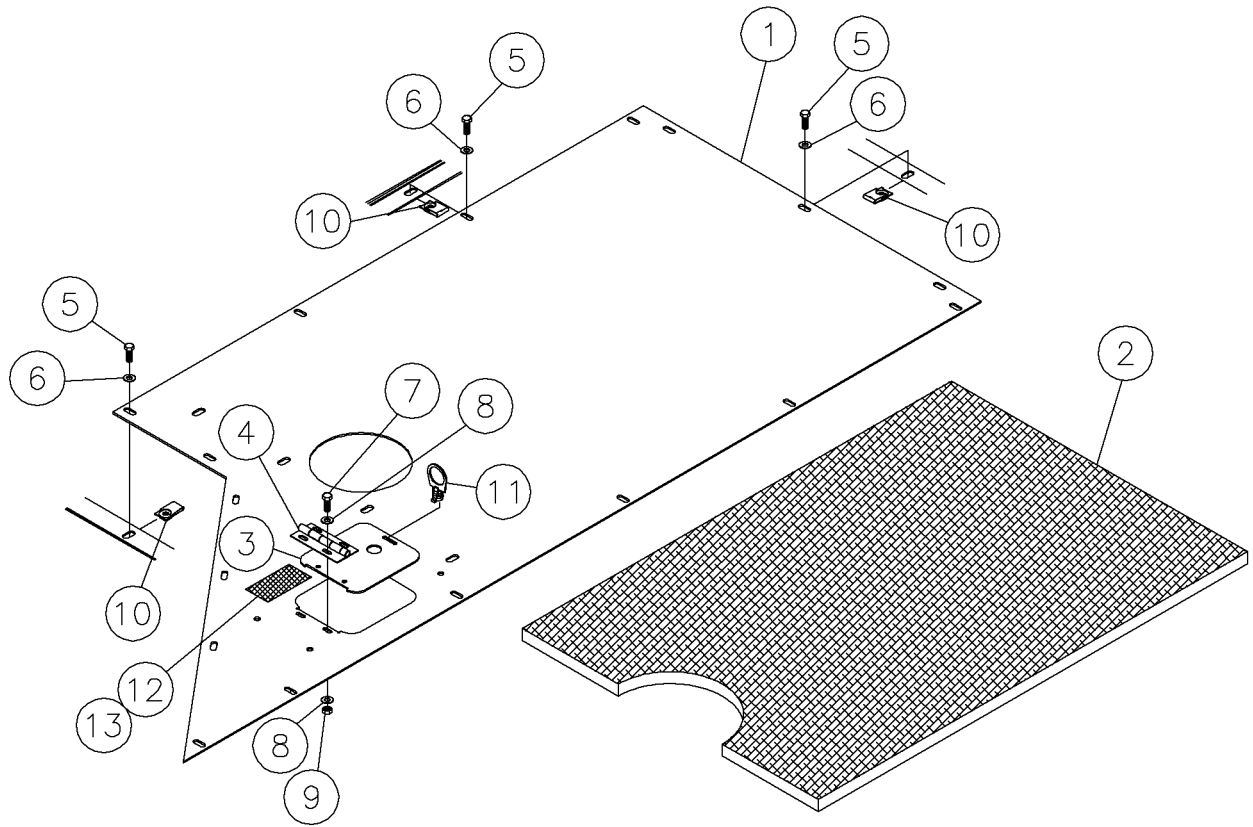

Shield-Top Rear Engine Bay Assy Fig 4-3

REF. NO.	*	PART NO.	DESCRIPTION	QTY.	REMARKS
1		293721001	SHIELD - TOP REAR ENGINE BAY	1	
2		296262607	FOAM - TOP REAR	1	
3		296256485	COVER - RADIATOR FILL	1	
4		293717001	HINGE - RADIATOR COVER	1	
5		235727001	BOLT-3/8-16X1 GR8 HEX ZINC PLT	17	
6		235713001	WASHER-3/8 SAE HARD ZINC PLTD	17	
7		235742001	BOLT-5/16-18X3/4 GR8 ZINC PLTD	4	
8		235714001	WASHER-5/16 SAE HARD ZINC PLTD	8	
9		235741001	NUT-5/16-18 GR8 ZINC PLTD	4	
10		13323001	U-CLIP - 3/8-16	17	
11		86113001	FASTENER-1/4 TURN	1	
12		2326315	DECAL-WARNING	1	
13		2326I315	DECAL-WARNING	1	International

Shield-Top Front Engine Bay Assy Fig 4-4

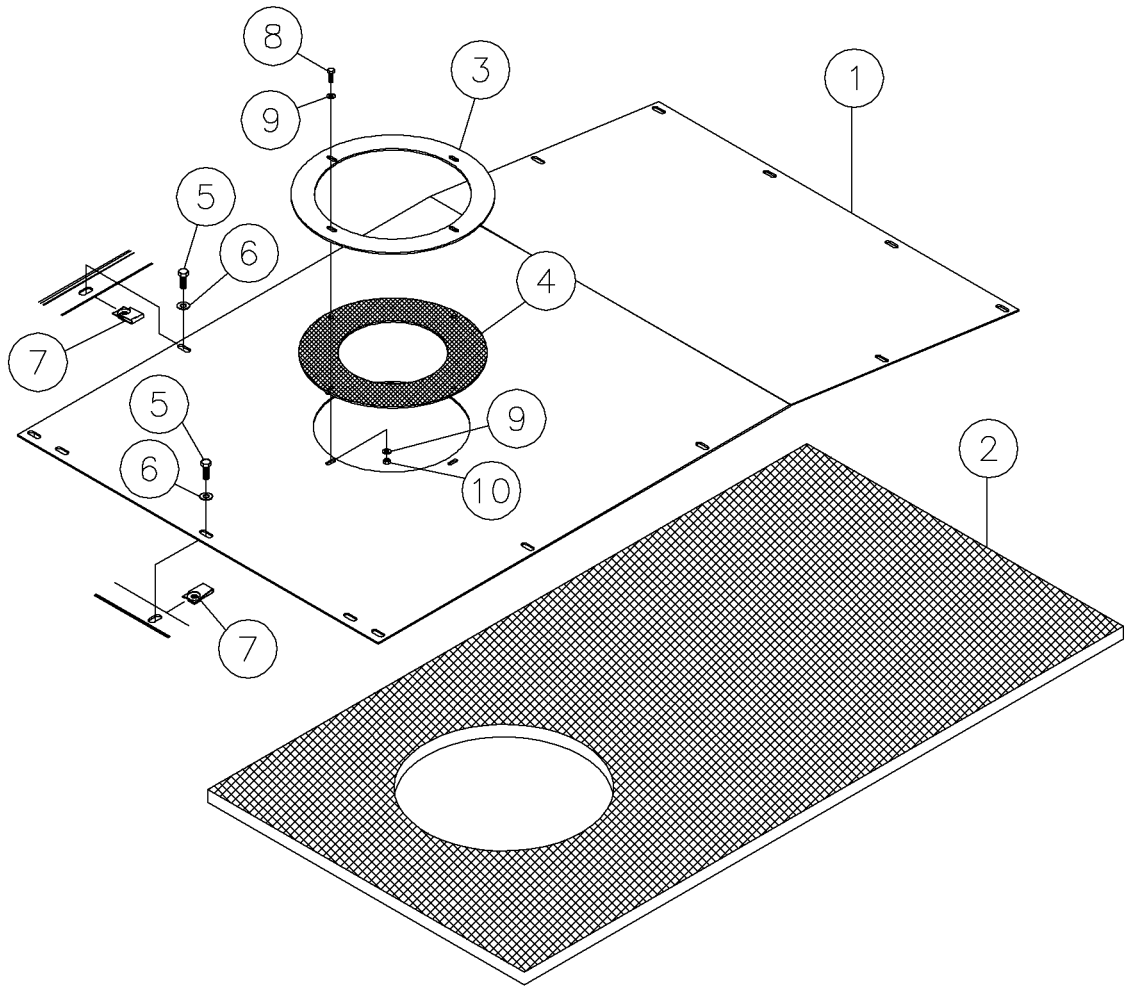

Shield-Top Front Engine Bay Assy Fig 4-4

REF. NO.	*	PART NO.	DESCRIPTION	QTY.	REMARKS
1		293720001	SHIELD - TOP FRONT ENGINE BAY	1	
2		296262605	FOAM - TOP FRONT	1	
3		293714001	PLATE - FLANGE	1	
4		293715001	SEAL - FLANGE	1	
5		235727001	BOLT-3/8-16X1 GR8 HEX ZINC PLT	14	
6		235713001	WASHER-3/8 SAE HARD ZINC PLTD	14	
7		13323001	U-CLIP - 3/8-16	14	
8		235742001	BOLT-5/16-18X3/4 GR8 ZINC PLTD	4	
9		235714001	WASHER-5/16 SAE HARD ZINC PLTD	8	
10		235741001	NUT-5/16-18 GR8 ZINC PLTD	4	

Shield-Engine Assy Fig 4-5

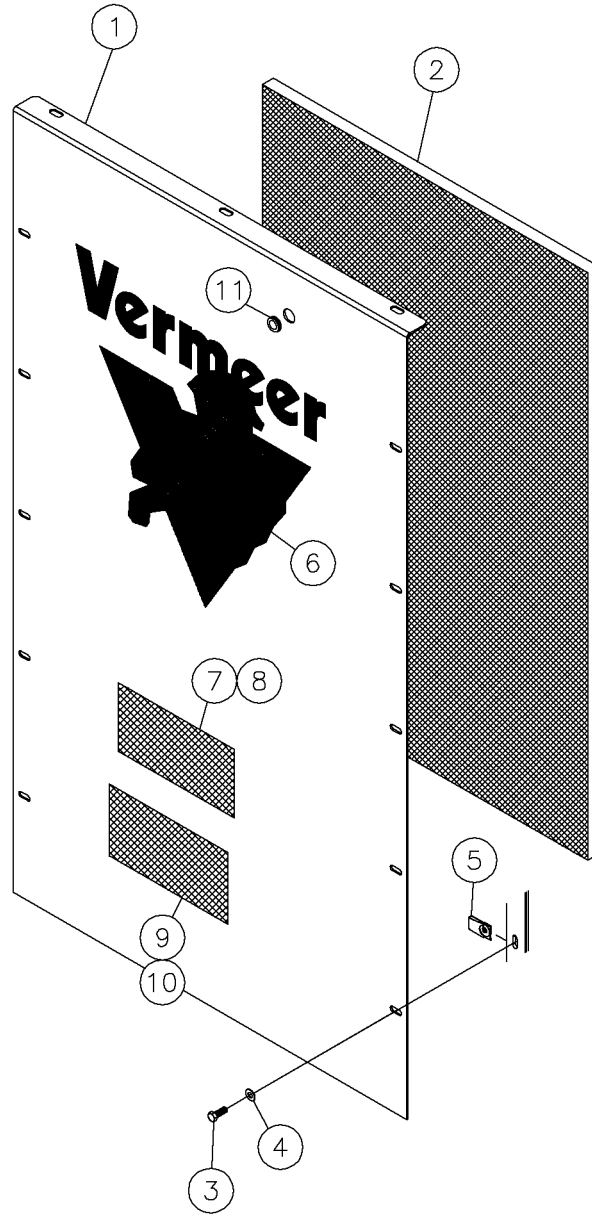

Shield-Engine Assy Fig 4-5

REF. NO.	*	PART NO.	DESCRIPTION	QTY.	REMARKS
1		296256361	SHIELD - REAR ENGINE BAY	1	
2		296256437	FOAM - REAR	1	
3		235727001	BOLT-3/8-16X1 GR8 HEX ZINC PLT	13	
4		235713001	WASHER-3/8 SAE HARD ZINC PLTD	13	
5		13323001	U-CLIP - 3/8-16	13	
6		70000940	DECAL-20" VERMEER LOGO	1	
7		7000B623	DECAL - DANGER ELECTRIC SHOCK	1	
8		700IB623	DECAL - DANGER ELECTRIC SHOCK	1	
9		7000B617	DECAL - DANGER POWER LINES	1	
10		700IB617	DECAL - DANGER POWER LINES	1	
11		1865043	GROMMET-.75IDX1.38OD-.19GROOVE	1	

Shield-Right/Left Top Corner Assy Fig 4-6

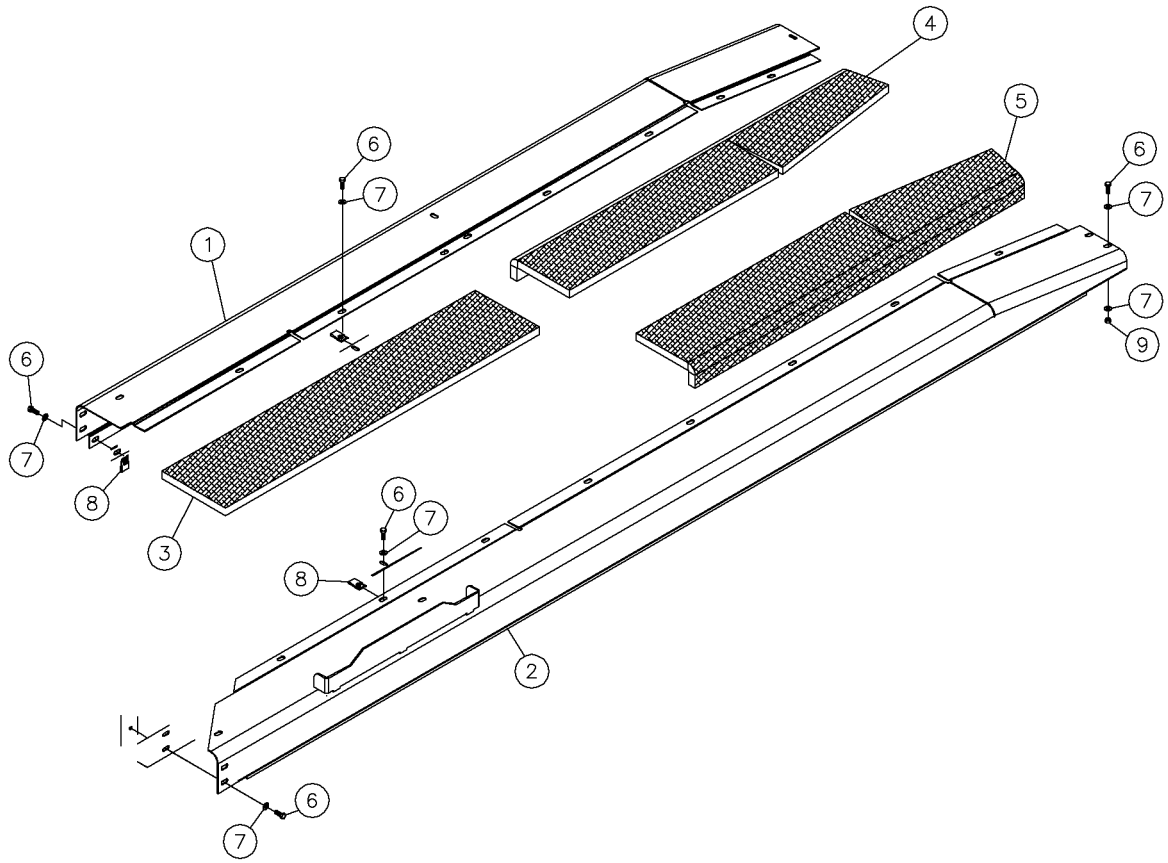

Shield-Right/Left Top Corner Assy Fig 4-6

REF. NO.	*	PART NO.	DESCRIPTION	QTY.	REMARKS
1		296256484	PANEL - LEFT TOP CORNER	1	
2		296262542	PANEL - WELDMENT	1	
3		296262608	FOAM - TOP REAR LEFT	1	
4		296262610	FOAM - TOP FRONT RIGHT	1	
5		296262609	FOAM - TOP FRONT LEFT	1	
6		235727001	BOLT-3/8-16X1 GR8 HEX ZINC PLT	30	
7		235713001	WASHER-3/8 SAE HARD ZINC PLTD	36	
8		13323001	U-CLIP - 3/8-16	21	
9		235725001	NUT-3/8-16 GR8 ZINC PLTD	7	

Shield-Door Track Assy Fig 4-7

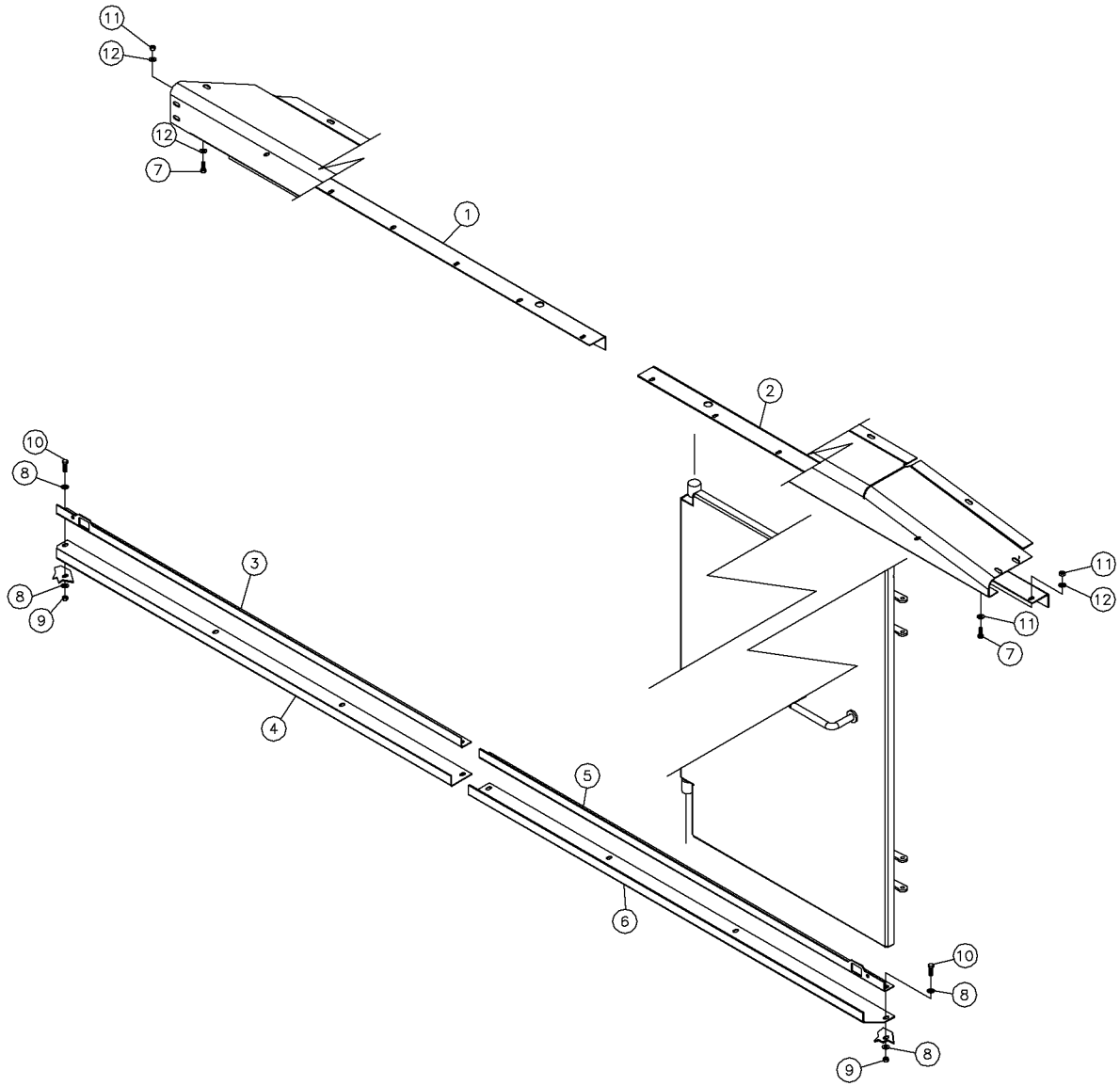

Shield-Door Track Assy Fig 4-7

REF. NO.	*	PART NO.	DESCRIPTION	QTY.	REMARKS
1		288920001	ANGLE - TRACK UPPER	1	
2		288921001	ANGLE - TRACK UPPER	1	
3		288917001	ANGLE - TRACK LOWER	1	
4		288919001	ANGLE - TRACK LOWER	1	
5		288916001	ANGLE - TRACK LOWER	1	
6		288918001	ANGLE - TRACK LOWER	1	
7		238209001	BOLT-5/16-18X1 GR8 NEX ZINC YC	14	
8		235713001	WASHER-3/8 SAE HARD ZINC PLTD	16	
9		235725001	NUT-3/8-16 GR8 ZINC PLTD	8	
10		235736001	BOLT-3/8-16X1 1/4 ZINC PLTD	8	
11		235741001	NUT-5/16-18 GR8 ZINC PLTD	14	
12		235714001	WASHER-5/16 SAE HARD ZINC PLTD	28	

Shield-Floating Door Assy Fig 4-8

Vernier



SHOWN ON REAR
LEFT DOOR

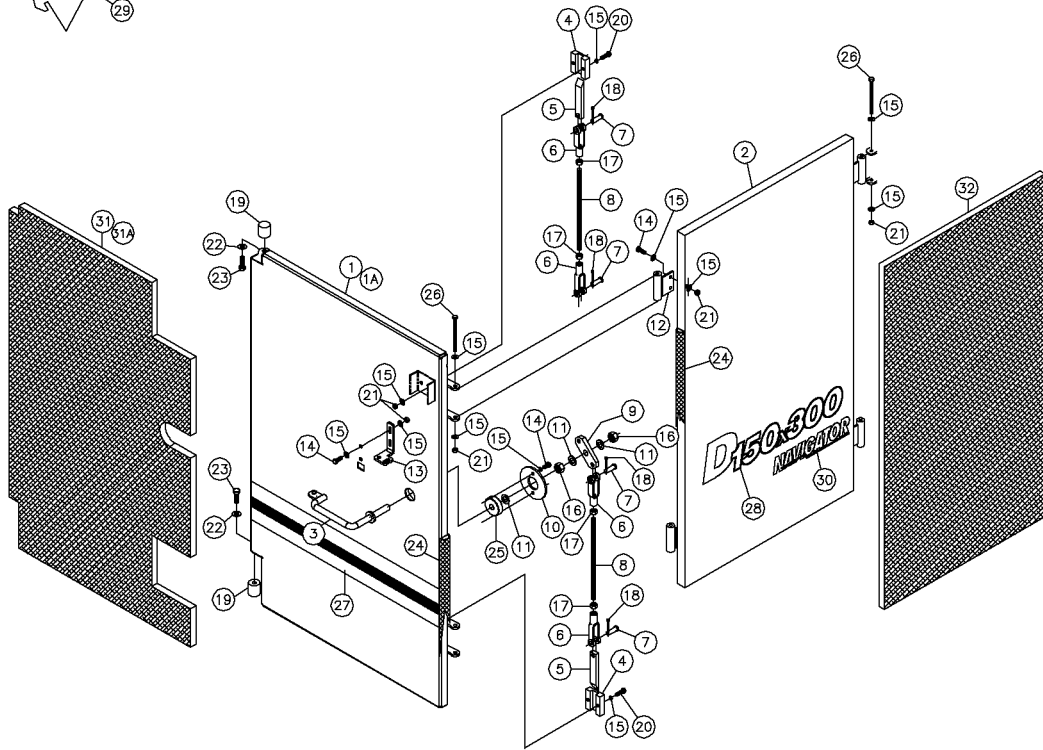

Shield-Floating Door Assy Fig 4-8

REF. NO.	*	PART NO.	DESCRIPTION	QTY.	REMARKS
1		293526001	WELDMENT - FLOATING DOOR, FRONT	1	
1A		293525001	WELDMENT - FLOATING DOOR REAR	1	Rear Door Not Shown
2		293524001	DOOR -WELDMENT	1	
3		293730001	HANDLE RIGHT DOOR	1	
4		296257387	LATCH MOUNT	2	
5		110000001	LATCH - DOOR ASSY	2	
6		2872001	YOKE-8N300A1/2"-1/2" PIN	4	
7		2110025	PIN-CLEVIS 1/2X1 3/8-1 3/16 UL	4	
8		296256488	ROD	2	
9		296256489	PLATE - DOOR ARM LEVER	1	
10		109997001	HOUSING CAP-DOOR BEARING	1	
11		91093001	WASHER-13/16ID 1 7/8OD HARDEN	3	
12		288926001	HINGE ASSEMBLY	4	
13		296256444	STOP	1	
14		235727001	BOLT-3/8-16X1 GR8 HEX ZINC PLT	12	
15		235713001	WASHER-3/8 SAE HARD ZINC PLTD	38	
16		510328311	NUT-HEXJAM-.75-16-GR2-YZ	2	
17		250525001	NUT - 1/2 - 20 NF HEX Y/ZINC	4	
18		510009	COTTER PIN-1/8" X 1"	4	
19		293635001	GUIDE - DOOR	4	
20		235723001	BOLT-3/8-16X1 1/2 GR8 ZINC PLT	4	
21		250508001	NUT - 3/8-NC GR8 TOP LOCK Y/ZINC	14	
22		485025	WASHER-1/2 FLAT-HARDENED-ZINC	2	
23		235721001	BOLT-1/2-13X1 1/2 GR8 ZINC PLT	2	
24		288982001	SEAL - 1" X 1" HALF ROUND	A/R	P/N Qty Of 1 = 1 Each
25		296256481	BUSHING	2	
26		244066001	BOLT-3/8-16X5 1/2 GD 8 ZNC PL	4	
27		70000777	DECAL 6"VERMEER STRIPE	A/R	P/N Qty Of 1 = 1 Foot
28		7000B411	DECAL-20" VERMEER LOGO	1	
29		70000940	DECAL-20" VERMEER LOGO	1	
30		70000614	DECAL-MODEL NAVIGATOR (BIG)	1	
31		296262611	FOAM - FRONT FLOATING DOOR	1	Rear Door Not Shown
31A		296262612	FOAM - REAR FLOATING DOOR	1	
32		296262613	FOAM - ANCHOR DOOR	2	

Hyd-Pump-Ground Drive/Thrust-Pullback Assy Fig 5-1r01

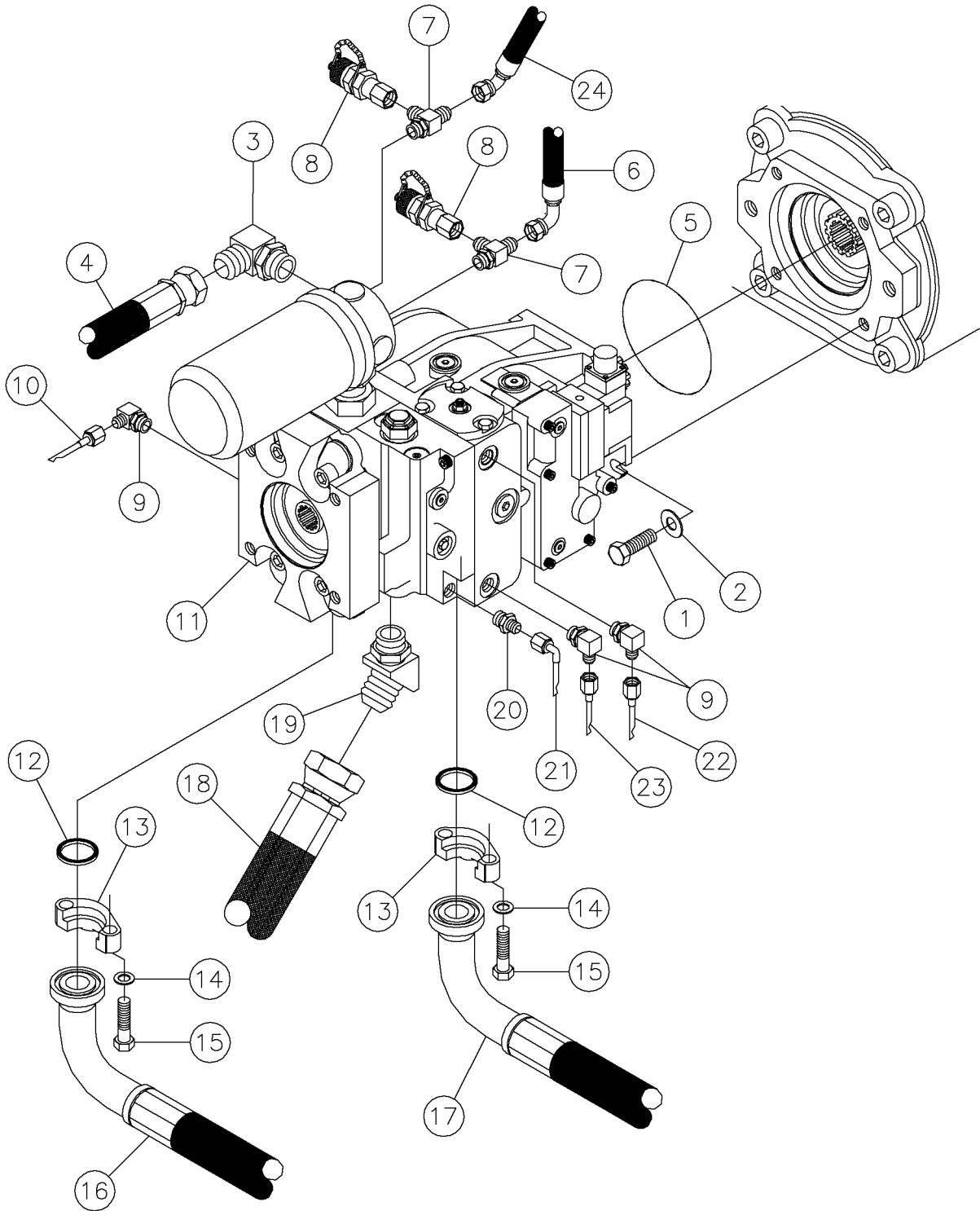

Hyd-Pump-Ground Drive/Thrust-Pullback Assy Fig 5-1r01

REF. NO.	*	PART NO.	DESCRIPTION	QTY.	REMARKS
		Revision Date	October, 2004		Update In Illustration & Parts List.
1		240334001	BOLT-1/2-13X1 3/4 GR8 ZINC PLT	4	
2		485025	WASHER-1/2 FLAT-HARDENED-YZ	4	
3		59410001	FITTING-90-12MJ-12MORBA	1	
4		53845151	HOSE-3/4X12 12FS JIC (100R1)	1	
5		85642163	O-RING	1	
6		257521001	HOSE-HYD 3/8 X 100" 6FS JIC ST/90	1	
7		68774001	FITTING-6MX6M JIC (RUN)X6M JIC	2	
8		130600001	FITTING - TEST - 6FSJ - 16MTP WITH ORING	2	
9		57950001	FITTING-90-4MJ-6MORBA	3	
10		296258421	HOSE - .08 X 18 4FS JIC ST/ST MICRO	1	
11		296261912	PUMP - HYD 90 SERIES 75 CC (FRONT)	1	Breakdown Fig 12-11
12		72895001	O RING-SQ. #16 FLANGE	2	
13		67745001	FITTING - FLGH - 16CD62	8	
14		250515001	7/16 HARD WASHER SAE Y/ZINC	8	
15		250507001	BOLT 7/16-14 X 1 3/4"GR8 HEX Y	8	
16		296258388	HOSE - 1.00 X 54 16C62/16FS MEGA 90L/ST G6K	1	
17		296256873	HOSE - 1.00 X 43 16C62/16FS MEGA 90SHORT/ST G6K	1	
18		296258411	HOSE - 1.25 X 28 20FSJIC ST/ST G4H	1	
19		86234001	16M ORING X 20M JIC 45DEG.	1	
20		57968001	FITTING-STR-4MJ-6MORB	1	
21		296258424	HOSE - .08 X 25 4FS JIC ST/90 MICRO	1	
22		296258422	HOSE - .08 X 26 4FS JIC ST/ST MICRO	1	
23		296258423	HOSE - .08 X 24 4FS JIC ST/ST MICRO	1	
24		148975001	HOSE - 3/8 X 19 6FSJIC ST/90 3000#	1	

Hyd-Pump-Ground Drive/Thrust-Pullback Assy Fig 5-1

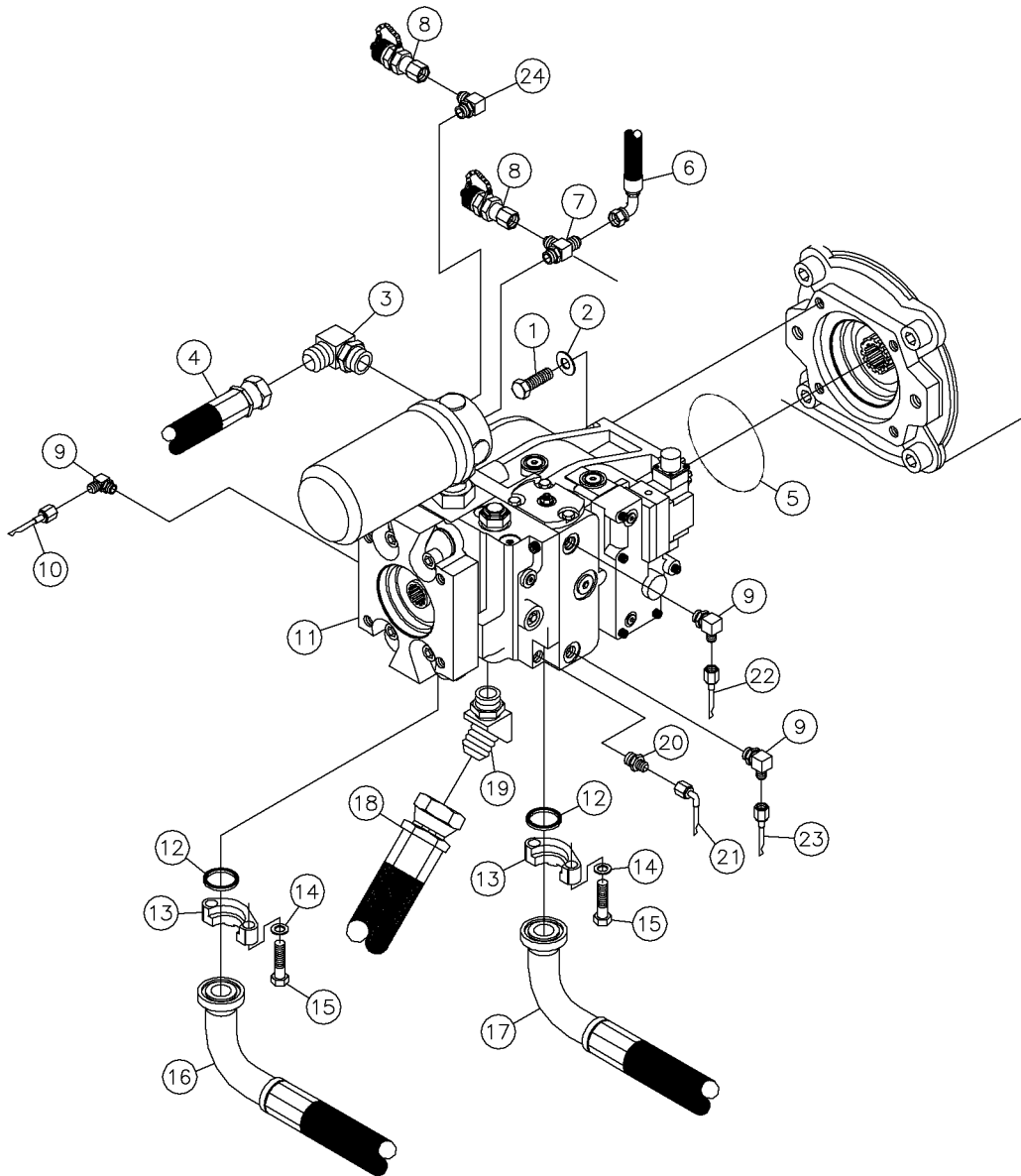

Hyd-Pump-Ground Drive/Thrust-Pullback Assy Fig 5-1

REF. NO.	*	PART NO.	DESCRIPTION	QTY.	REMARKS
1		240334001	BOLT-1/2-13X1 3/4 GR8 ZINC PLT	4	
2		485025	WASHER-1/2 FLAT-HARDENED-ZINC	4	
3		59410001	12M JICX12M ADJ. 90 DEG.ELBOW	1	
4		53845151	HOSE-3/4X12 12FS JIC (100R1)	1	
5		85642163	O-RING	1	
6		257521001	HOSE-HYD 3/8 X 100" 6FS JIC ST/90	1	
7		68774001	FITTING-6MX6M JIC (RUN)X6M JIC	1	
8		130600001	COUPLER-DIAGNOSTIC 6FJIC	2	
9		57950001	FITTING-90-4MJ-6MORBA	3	
10		296258421	HOSE - .08 X 18 4FS JIC ST/ST MICRO	1	
11		296261912	PUMP - HYD 90 SERIES 75 CC (FRONT)	1	Breakdown Fig 12-11
12		72895001	O RING-SQ. #16 FLANGE	2	
13		67745001	SPLIT FLANGE HALF CODE 62/16	8	
14		250515001	7/16 HARD WASHER SAE Y/ZINC	8	
15		250507001	BOLT 7/16-14 X 1 3/4"GR8 HEX Y	8	
16		296258388	HOSE - 1.00 X 54 16C62/16FS JICM 90L/ ST G6K	1	
17		296256873	HOSE - 1.00 X 43 16C62/16FS MEGA 90SHORT/ST G6K	1	
18		296258411	HOSE - 1.25 X 28 20C62 ST/ST G4H	1	
19		86234001	16M ORING X 20M JIC 45DEG.	1	
20		57968001	FITTING-STR-4MJ-6MORB	1	
21		296258424	HOSE - .08 X 25 4FS JIC ST/90 MICRO	1	
22		296258422	HOSE - .08 X 26 4FS JIC ST/ST MICRO	1	
23		296258423	HOSE - .08 X 24 4FS JIC ST/ST MICRO	1	
24		59426001	FITTING - 6M JIC X 6M O-RING ADJ 90 ELBOW	1	

Hyd-Pump-Ground Drive/Thrust-Pullback Assy Fig 5-2r01

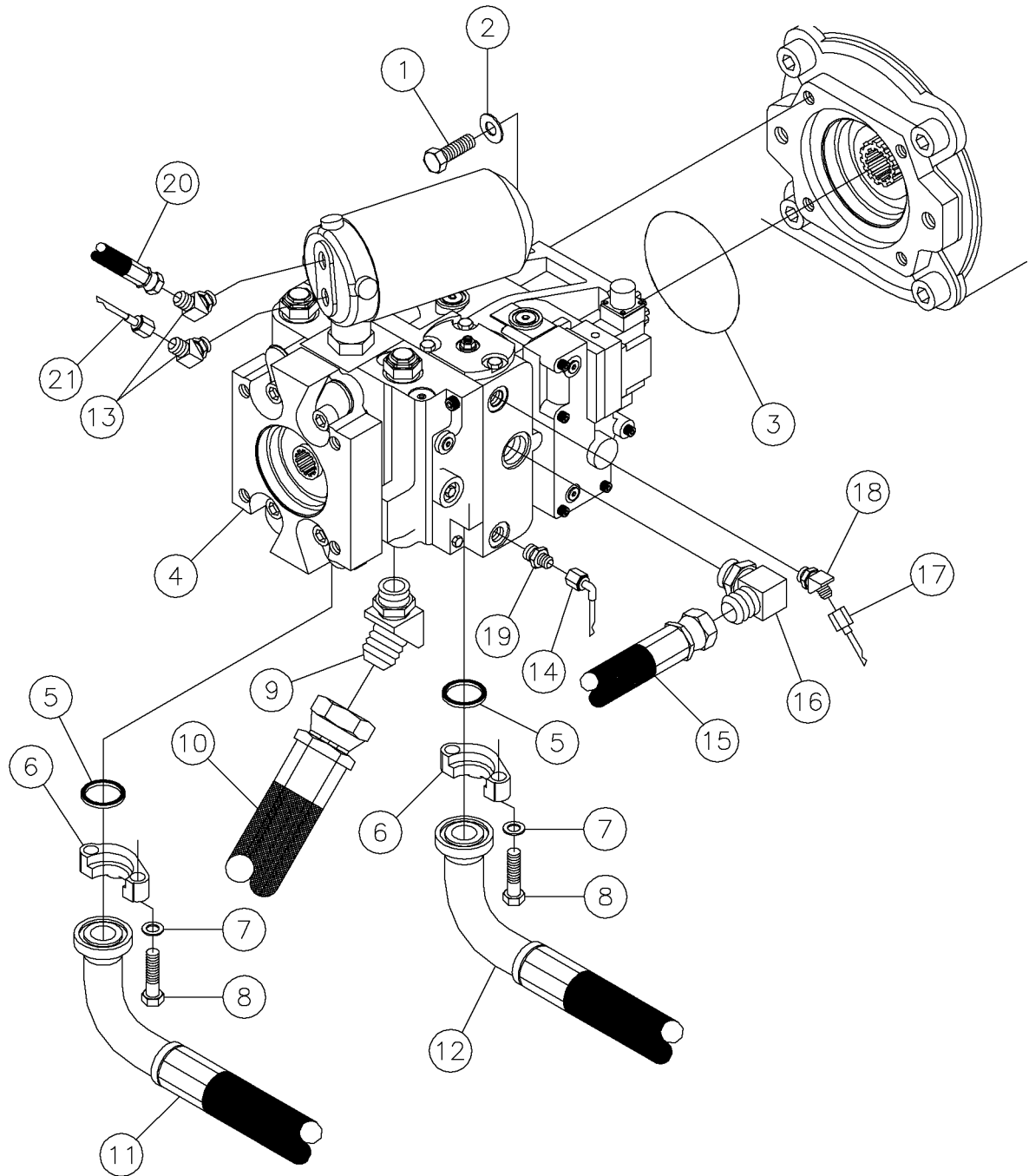

Hyd-Pump-Ground Drive/Thrust-Pullback Assy Fig 5-2r01

REF. NO.	*	PART NO.	DESCRIPTION	QTY.	REMARKS
		Revision Date	October, 2004		Update In Illustration & Parts List.
1		240334001	BOLT-1/2-13X1 3/4 GR8 ZINC PLT	4	
2		485025	WASHER-1/2 FLAT-HARDENED-YZ	4	
3		85642163	O-RING	1	
4		296261912	PUMP - HYD 90 SERIES 75 CC (FRONT)	1	Breakdown Fig 12-11
5		72895001	O RING-SQ. #16 FLANGE	2	
6		67745001	FITTING - FLGH - 16CD62	4	
7		250515001	7/16 HARD WASHER SAE Y/ZINC	8	
8		250507001	BOLT 7/16-14 X 1 3/4"GR8 HEX Y	8	
9		86234001	16M ORING X 20M JIC 45DEG.	1	
10		296258411	HOSE - 1.25 X 28 20FSJIC ST/ST G4H	1	
11		296258392	HOSE - 1.00 X 50 16C62/16FS MEGA 90L/ST G6K	1	
12		296256874	HOSE - 1.00 X 53 16C62/16FS MEGA 90/ST G6K	1	
13		65563001	FITTING - 6M O-RING X 6M JIC 45 DEGREE	2	
14		296258425	HOSE - .08 X 34 4FS JIC ST/90 MICRO	1	
15		53845151	HOSE-3/4X12 12FS JIC (100R1)	1	
16		59410001	FITTING-90-12MJ-12MORBA	1	
17		296258416	HOSE - .08 X 41 4FS JIC ST/ST MICRO	1	
18		82931001	FITTING-45-4MJX6MORBA	1	
19		57968001	FITTING-STR-4MJ-6MORB	1	
20		278800001	HOSE-3/8X23 6FSJIC ST/90 M3K	1	
21		296256904	HOSE - .08 X 31 4FS/6FS JIC ST/ST MICRO	1	

Hyd-Pump-Ground Drive/Thrust-Pullback Assy Fig 5-2

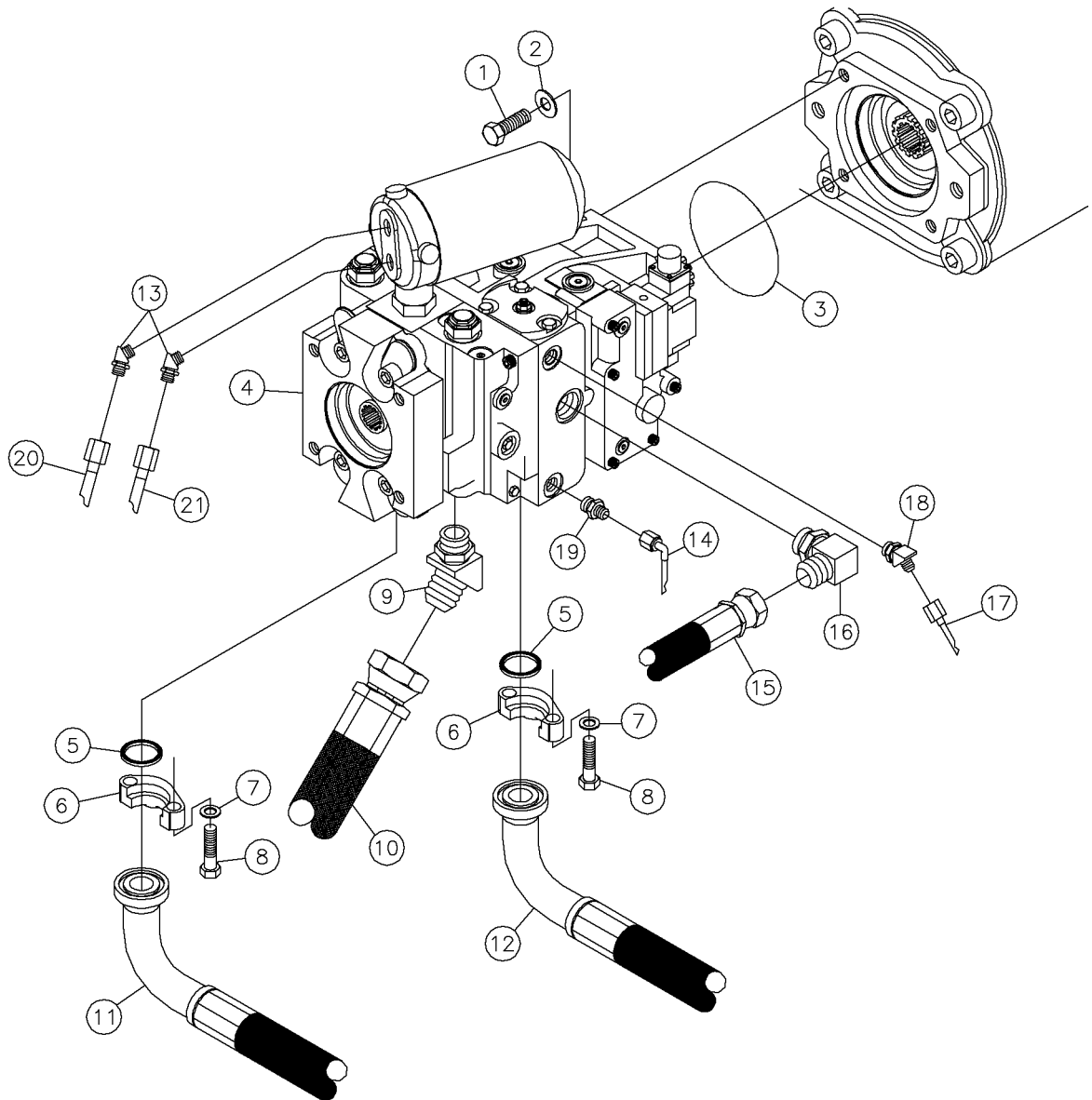

Hyd-Pump-Ground Drive/Thrust-Pullback Assy Fig 5-2

REF. NO.	*	PART NO.	DESCRIPTION	QTY.	REMARKS
1		240334001	BOLT-1/2-13X1 3/4 GR8 ZINC PLT	4	
2		485025	WASHER-1/2 FLAT-HARDENED-ZINC	4	
3		85642163	O-RING	1	
4		296261912	PUMP - HYD 90 SERIES 75 CC (FRONT)	1	Breakdown Fig 12-11
5		72895001	O RING-SQ. #16 FLANGE	2	
6		67745001	SPLIT FLANGE HALF CODE 62/16	4	
7		250515001	7/16 HARD WASHER SAE Y/ZINC	8	
8		250507001	BOLT 7/16-14 X 1 3/4"GR8 HEX Y	8	
9		86234001	16M ORING X 20M JIC 45DEG.	1	
10		296258411	HOSE - 1.25 X 28 20FSJIC ST/ST G4H	1	
11		296258392	HOSE - 1.00 X 50 16C62/16FS JICM 90L/ST G6K	1	
12		296256874	HOSE - 1.00 X 53 16C62/16FS MEGA 90/ST G6K	1	
13		65563001	FITTING - 6M O-RING X 6M JIC 45 DEGREE	2	
14		296258425	HOSE - .08 X 34 4FS JIC ST/90 MICRO	1	
15		53845151	HOSE-3/4X12 12FS JIC (100R1)	1	
16		59410001	12M JICX12M ADJ. 90 DEG.ELBOW	1	
17		296258416	HOSE - .08 X 41 4FS JIC ST/ST MICRO	1	
18		82931001	FITTING-6MX4M JIC 45DEG.ELBOW	1	
19		57968001	FITTING-STR-4MJ-6MORB	1	
20		296256903	HOSE - .08 X 34 4FS JIC ST/ST MICRO	1	
21		296256904	HOSE - .08 X 31 4FS/6FS JIC ST/ST MICRO	1	

Hyd-Pump-Rotation Assy Fig 5-3r01

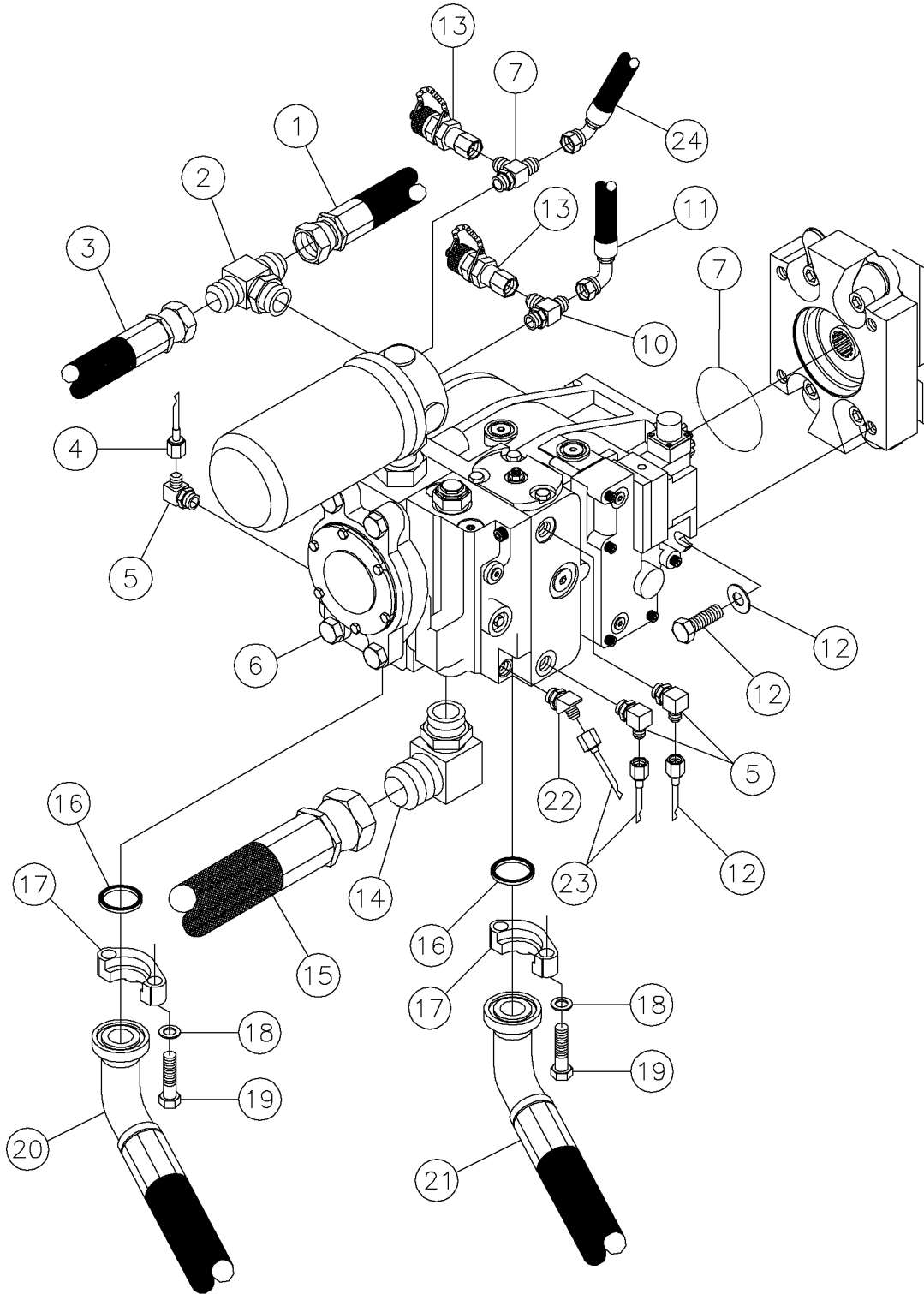

Hyd-Pump-Rotation Assy Fig 5-3r01

REF. NO.	*	PART NO.	DESCRIPTION	QTY.	REMARKS
		Revision Date	October, 2004		Update In Illustration & Parts List.
1		53845151	HOSE-3/4X12 12FS JIC (100R1)	1	
2		70032001	12M BCH X 12M JICX12M JIC TEE	1	
3		53845435	HOSE-3/4X26 12FS JIC 3000 PSI	1	
4		296258418	HOSE - .08 X 14 4FS JIC ST/ST MICRO	1	
5		57950001	FITTING-90-4MJ-6MORBA	3	
6		296261915	PUMP - HYD 90 SERIES 75 CC (REAR)	1	Breakdown Fig 12-12
7		85642163	O-RING	1	
8		240334001	BOLT-1/2-13X1 3/4 GR8 ZINC PLT	4	
9		485025	WASHER-1/2 FLAT-HARDENED-YZ	4	
10		68774001	FITTING-6MX6M JIC (RUN)X6M JIC	1	
11		296256871	HOSE - .375 X 26 6FS JIC ST/90 M3K	1	
12		296258420	HOSE - .08 X 28 4FS JIC ST/ST MICRO	1	
13		130600001	FITTING - TEST - 6FSJ - 16MTP WITH ORING	1	
14		65573001	16M X 20M JIC 90 DEGREE	1	
15		296258410	HOSE - 1.25 X 24 20FS JIC 45/ST G4H	1	
16		72895001	O RING-SQ. #16 FLANGE	2	
17		67745001	FITTING - FLGH - 16CD62	4	
18		250515001	7/16 HARD WASHER SAE Y/ZINC	8	
19		250507001	BOLT 7/16-14 X 1 3/4"GR8 HEX Y	8	
20		296258384	HOSE - 1.00 X 53 16C62/16FS MEGA 45/ST G6K	1	
21		296258385	HOSE - 1.00 X 45 16C62/16FS MEGA 45/ST G6K	1	
22		82931001	FITTING-45-4MJX6MORBA	1	
23		296258419	HOSE - .08 X 21 4FS JIC ST/ST MICRO	2	
24		72056001	FITTING-TEST-6MORB-16MTP	1	

Hyd-Pump-Rotation Assy Fig 5-3

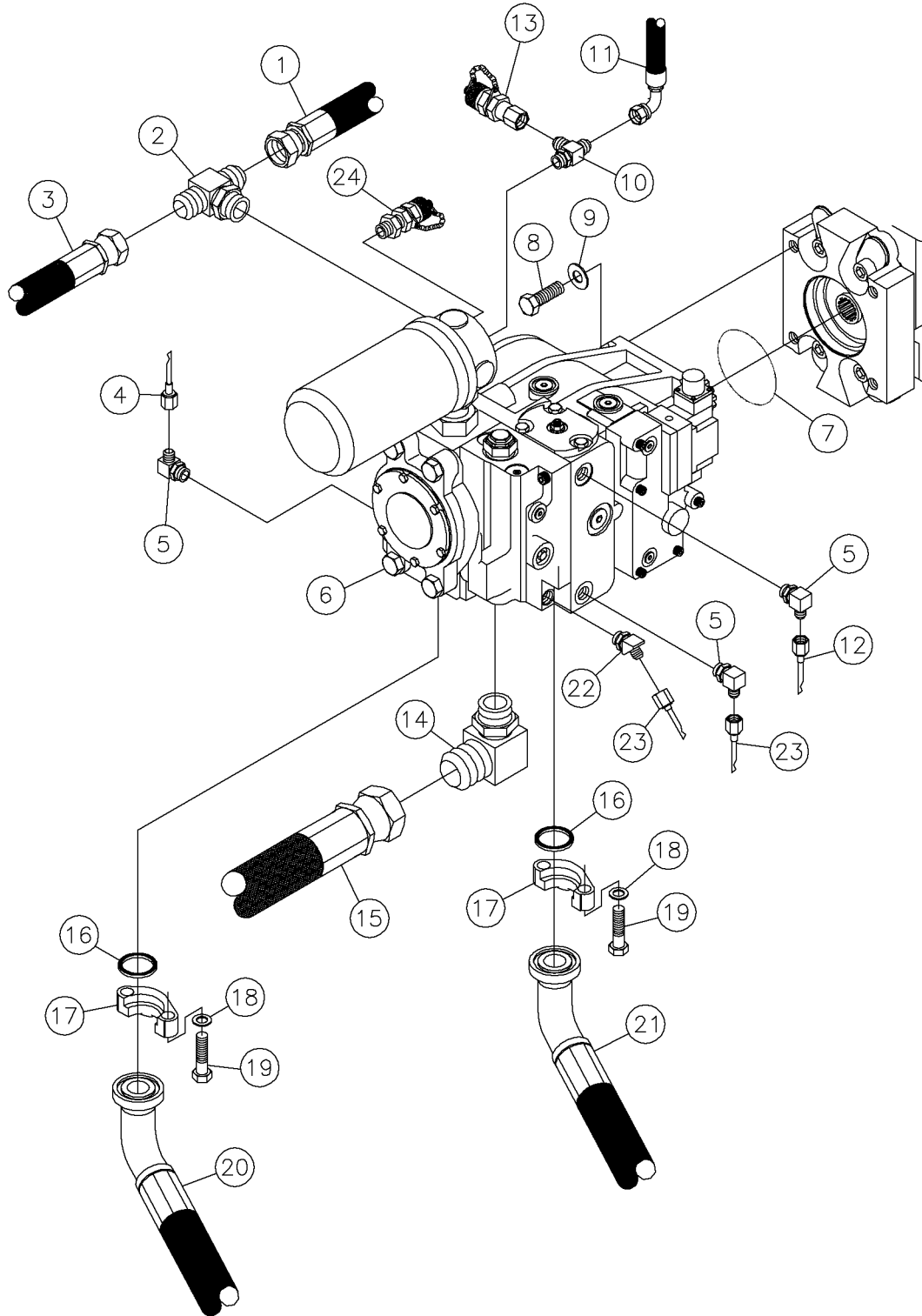

Hyd-Pump-Rotation Assy Fig 5-3

REF. NO.	*	PART NO.	DESCRIPTION	QTY.	REMARKS
1		53845151	HOSE-3/4X12 12FS JIC (100R1)	1	
2		70032001	12M BCH X 12M JICX12M JIC TEE	1	
3		53845435	HOSE-3/4X26 12FS JIC 3000 PSI	1	
4		296258418	HOSE - .08 X 14 4FS JIC ST/ST MICRO	1	
5		57950001	FITTING-90-4MJ-6MORBA	3	
6		296261915	PUMP - HYD 90 SERIES 75 CC (REAR)	1	Breakdown Fig12-12
7		85642163	O-RING	1	
8		240334001	BOLT-1/2-13X1 3/4 GR8 ZINC PLT	4	
9		485025	WASHER-1/2 FLAT-HARDENED-ZINC	4	
10		68774001	FITTING-6MX6M JIC (RUN)X6M JIC	1	
11		296256871	HOSE - .375 X 26 6FS JIC ST/90 M3K	1	
12		296258420	HOSE - .08 X 28 4FS JIC ST/ST MICRO	1	
13		130600001	COUPLER-DIAGNOSTIC 6FJIC	1	
14		65573001	16M X 20M JIC 90 DEGREE	1	
15		296258410	HOSE - 1.25 X 24 20FS JIC 45/ST G4H	1	
16		72895001	O RING-SQ. #16 FLANGE	2	
17		67745001	SPLIT FLANGE HALF CODE 62/16	4	
18		250515001	7/16 HARD WASHER SAE Y/ZINC	8	
19		250507001	BOLT 7/16-14 X 1 3/4"GR8 HEX Y	8	
20		296258384	HOSE - 1.00 X 53 16C62/16FS MEGA 45/ ST G6K	1	
21		296258385	HOSE - 1.00 X 45 16C62/16FS MEGA 45/ ST G6K	1	
22		82931001	FITTING-6MX4M JIC 45DEG.ELBOW	1	
23		296258419	HOSE - .08 X 21 4FS JIC ST/ST MICRO	2	
24		72056001	FITTING-TEST-6MORB-16MTP	1	

Hyd-Pump-Rotation Assy Fig 5-4r01

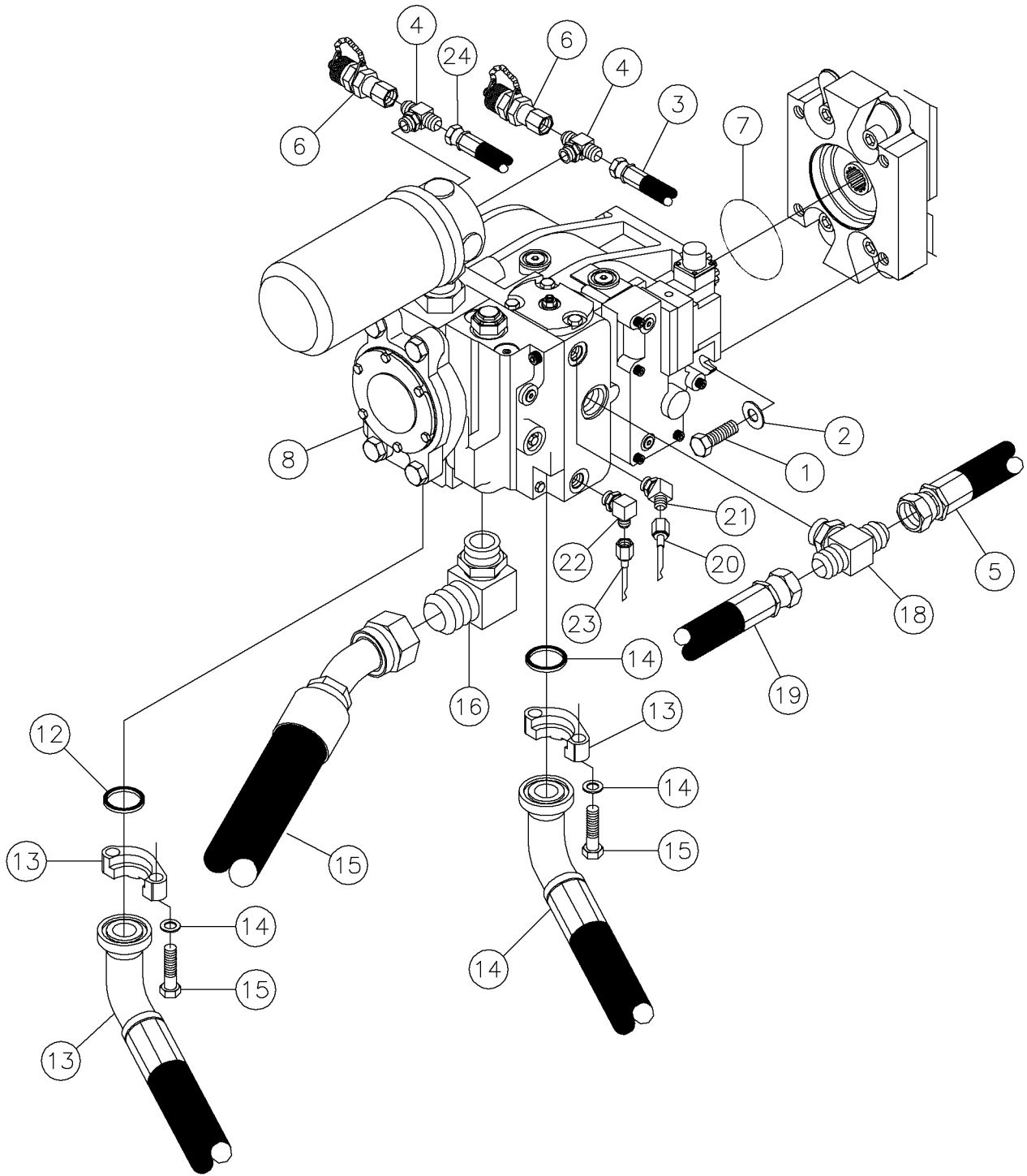

Hyd-Pump-Rotation Assy Fig 5-4r01

REF. NO.	*	PART NO.	DESCRIPTION	QTY.	REMARKS
		Revision Date	October, 2004		Update In Illustration & Parts List.
1		240334001	BOLT-1/2-13X1 3/4 GR8 ZINC PLT	4	
2		485025	WASHER-1/2 FLAT-HARDENED-YZ	4	
3		296256870	HOSE - .375 X 476 6FS JIC ST/ST M3K	1	
4		68787001	FITTING-6M (BCH)X6M JICX6M JIC	1	
5		53845151	HOSE-3/4X12 12FS JIC (100R1)	1	
6		130600001	FITTING - TEST - 6FSJ - 16MTP WITH ORING	1	
7		85642163	O-RING	1	
8		296261915	PUMP - HYD 90 SERIES 75 CC (REAR)	1	Breakdown Fig 12-12
9		72895001	O RING-SQ. #16 FLANGE	2	
10		67745001	FITTING - FLGH - 16CD62	4	
11		250515001	7/16 HARD WASHER SAE Y/ZINC	8	
12		250507001	BOLT 7/16-14 X 1 3/4"GR8 HEX Y	8	
13		296258380	HOSE - 1.00 X 4316C62/16FS MEGA 45/ST G6K	1	
14		296258381	HOSE - 1.00 X 36 16C62/16FS MEGA 45/ST G6K	1	
15		296258409	HOSE - 1.25 X 20 20FS 45/ST G4H	1	
16		65573001	16M X 20M JIC 90 DEGREE	1	
17		72056001	FITTING-TEST-6MORB-16MTP	1	
18		70032001	12M BCH X 12M JICX12M JIC TEE	1	
19		53845289	HOSE-3/4X43 12FS JIC 3000 PSI	1	
20		296258416	HOSE - .08 X 41 4FS JIC ST/ST MICRO	1	
21		82931001	FITTING-45-4MJX6MORBA	1	
22		57950001	FITTING-90-4MJ-6MORBA	1	
23		296266460	HOSE-0.375X15 6FJ 90/90-180 3000PSI 6M3K	1	

Hyd-Pump-Rotation Assy Fig 5-4

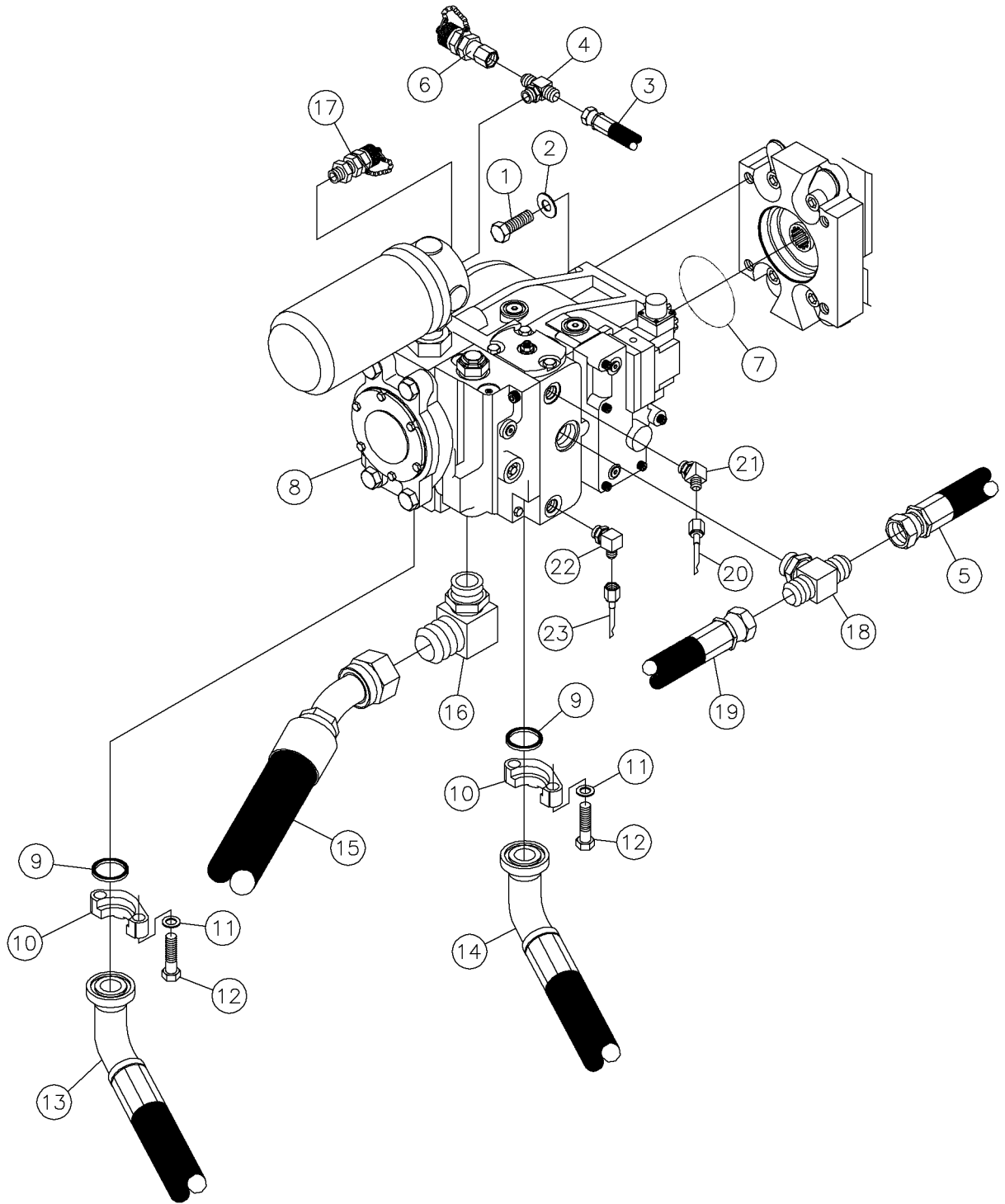

Hyd-Pump-Rotation Assy Fig 5-4

REF. NO.	*	PART NO.	DESCRIPTION	QTY.	REMARKS
1		240334001	BOLT-1/2-13X1 3/4 GR8 ZINC PLT	4	
2		485025	WASHER-1/2 FLAT-HARDENED-ZINC	4	
3		296256870	HOSE - .375 X 476 6FS JIC ST/ST M3K	1	
4		68787001	FITTING-6M (BCH)X6M JICX6M JIC	1	
5		53845151	HOSE-3/4X12 12FS JIC (100R1)	1	
6		130600001	COUPLER-DIAGNOSTIC 6FJIC	1	
7		85642163	O-RING	1	
8		296261915	PUMP - HYD 90 SERIES 75 CC (REAR)	1	Breakdown Fig 12-12
9		72895001	O RING-SQ. #16 FLANGE	2	
10		67745001	SPLIT FLANGE HALF CODE 62/16	4	
11		250515001	7/16 HARD WASHER SAE Y/ZINC	8	
12		250507001	BOLT 7/16-14 X 1 3/4"GR8 HEX Y	8	
13		296258380	HOSE - 1.00 X 43 16C62/16FS JICM 45/ ST G6K	1	
14		296258381	HOSE - 1.00 X 36 16C62/16FS JICM 45/ ST G6K	1	
15		296258409	HOSE - 1.25 X 20 20C62 45/ST G4H	1	
16		65573001	16M X 20M JIC 90 DEGREE	1	
17		72056001	FITTING-TEST-6MORB-16MTP	1	
18		70032001	12M BCH X 12M JICX12M JIC TEE	1	
19		53845289	HOSE-3/4X43 12FS JIC 3000 PSI	1	
20		296258416	HOSE - .08 X 41 4FS JIC ST/ST MICRO	1	
21		82931001	FITTING-6MX4M JIC 45DEG.ELBOW	1	
22		57950001	FITTING-90-4MJ-6MORBA	1	
23		296258417	HOSE - .08 X 31 4FS JIC ST/ST MICRO	1	

Hyd-Pump-Fan Assy Fig 5-5

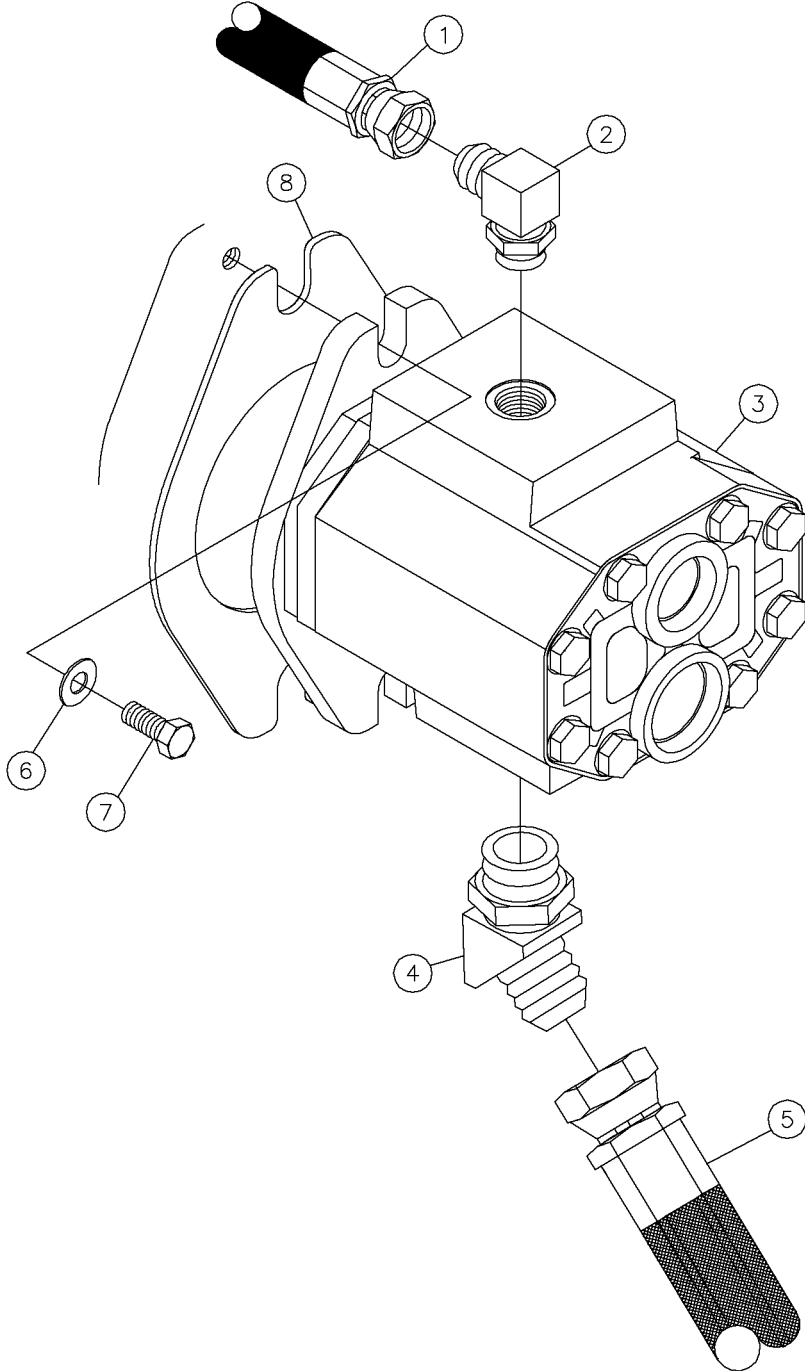

Hyd-Pump-Fan Assy Fig 5-5

REF. NO.	*	PART NO.	DESCRIPTION	QTY.	REMARKS
1		296261567	HOSE - HYD - .25 X 41.00 - 12FSJ - ST/45 -3000PSI	1	
2		59410001	FITTING-12M JICX12M ADJ. 90 DEG.ELBOW	1	
3		288985001	PUMP - GEAR, 2.318 CIR CW	1	Breakdown Fig 12-10
4		81703001	FITTING-20MX20M JIC 45 DEG.EL.	1	
5		296258415	HOSE - 1.25 X 84 20C62 ST/ST G4H	1	
6		485025	WASHER-1/2 FLAT-HARDENED-ZINC	2	
7		235737001	BOLT-1/2-13X1 1/4 GR8 ZINC PLT	2	
8		296261776	GASKET	1	

Hyd-Pump-Heat/Cool/Filter Assy Fig 5-6r02

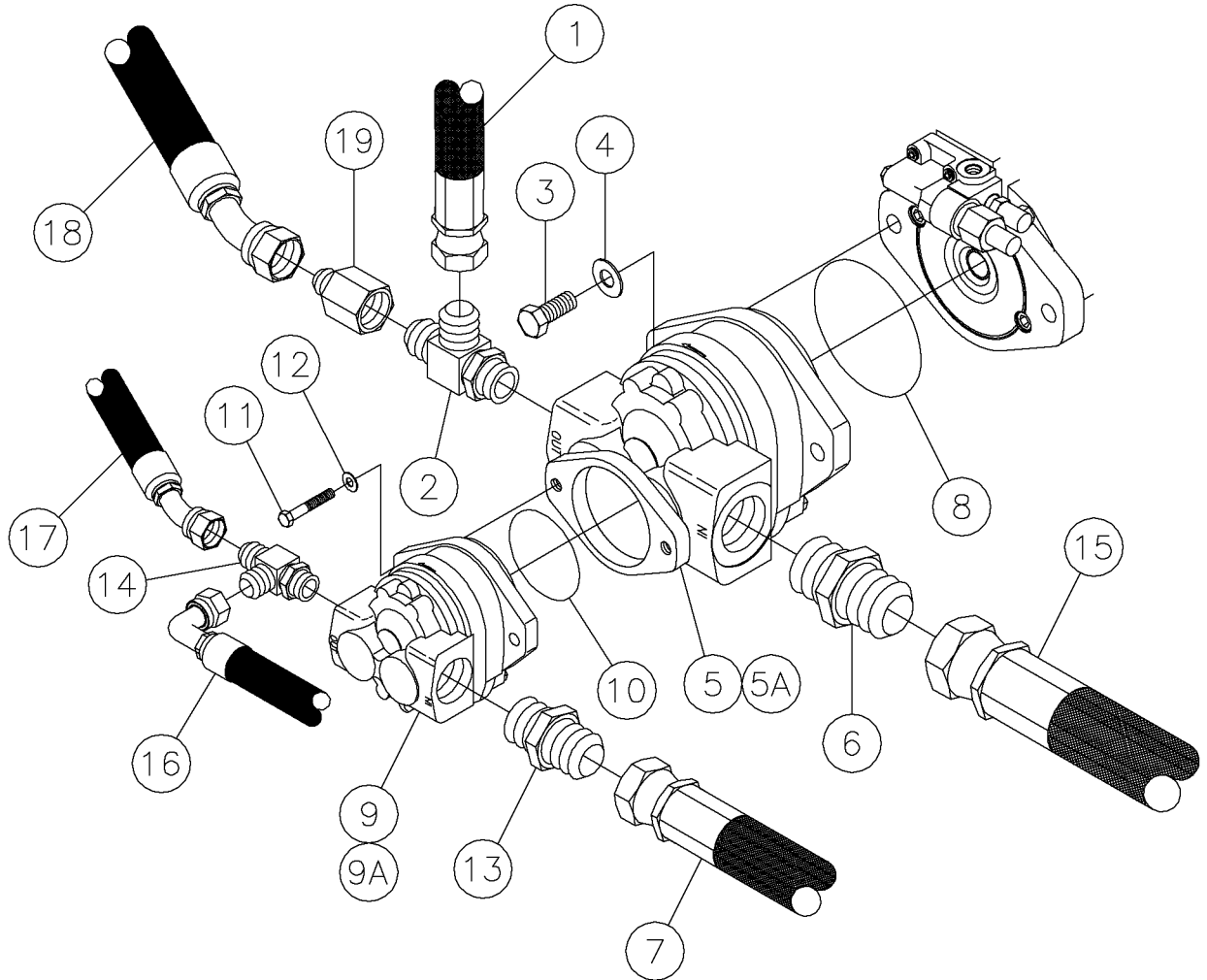

Hyd-Pump-Heat/Cool/Filter Assy Fig 5-6r02

REF. NO.	*	PART NO.	DESCRIPTION	QTY.	REMARKS
		Revision Date	October, 2004		Update In Illustration & Parts List.
1		53845187	HOSE-3/4X24 12FS JIC 2500 PSI	1	
2		59420001	12 JICX12M ADJ. STR THRD RUN TEE	1	
3		240334001	BOLT-1/2-13X1 3/4 GR8 ZINC PLT	2	
4		485025	WASHER-1/2 FLAT-HARDENED-YZ	2	
5		296267035	GEAR PUMP ASSY	1	
5A		296267051	SEAL KIT	1	
6		70006001	FITTING-20M X 20 M JIC STR.	1	
7		296016001	HOSE-HYD-1X36.0-16FSJ ST/ST 200PSI	1	
8		296267049	O-RING	1	
9		296267036	PUMP - GEAR .31 CUBIC IN/REV	1	
		296267050	SEAL KIT	1	
10		296267044	O-RING	1	
11		296267041	CAP SCREW	2	
12		296267042	WASHER	2	
13		60907001	FITTING-16M JICX16M STR ADAPT	1	
14		202883001	8M BCH X 8M JIC X 8M JIC TEE	1	
15		296258414	HOSE - 1.25 X 38 20FS ST/ST G4H	1	
16		296056001	HOSE-HYD-.50 X 366 8FSJ ST/903KPSI BNS	1	
17		53844425	HOSE-1/2X22 8FSJIC-8FSJIC 45	1	
18		296069001	HOSE-HYD-.50 X 18.0 8FSJ ST/45 3000PSI	1	
19		59421001	12F JICX8M JIC ST REDUCER FITTING	1	

Hyd-Pump-Heat/Cool/Filter Assy Fig 5-6r01

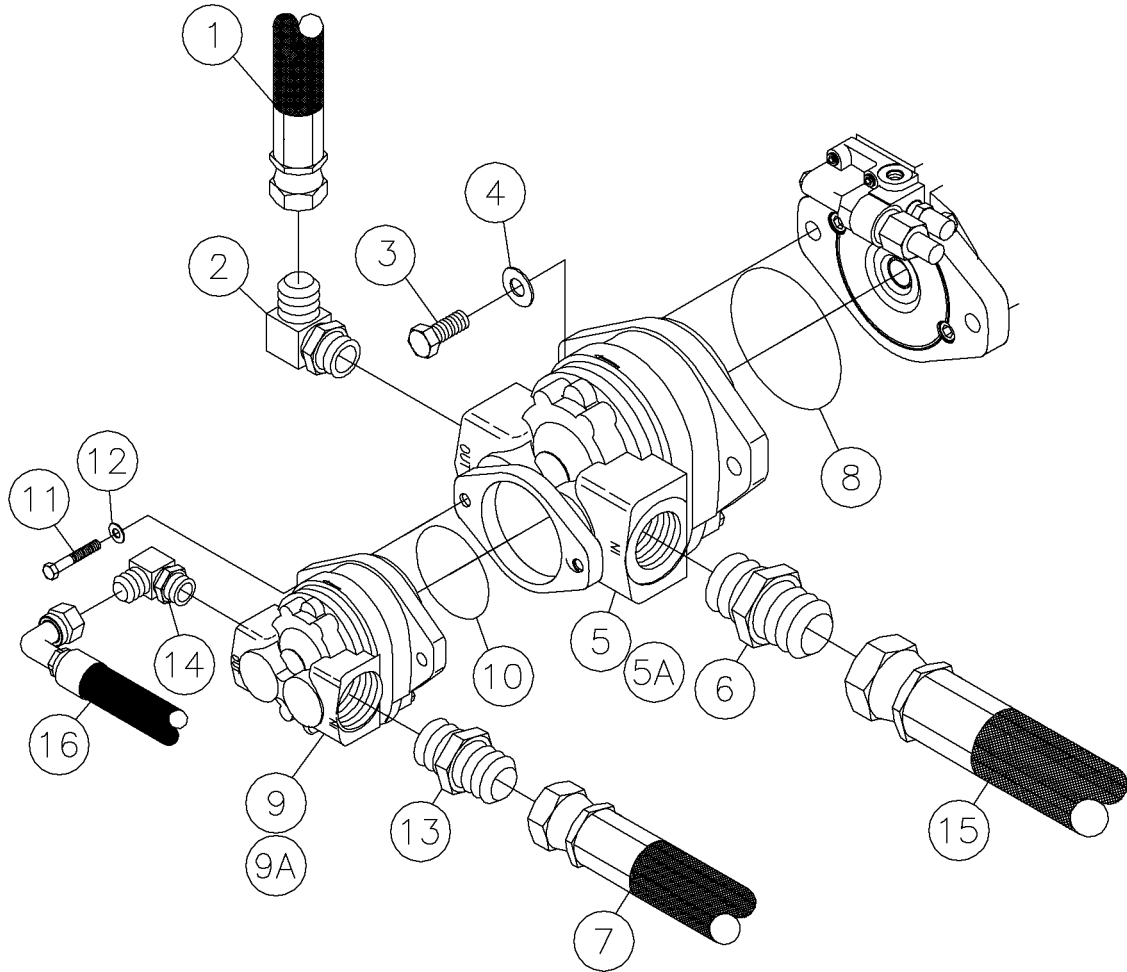

Hyd-Pump-Heat/Cool/Filter Assy Fig 5-6r01

REF. NO.	*	PART NO.	DESCRIPTION	QTY.	REMARKS
		Revision Date	June, 2002		Update In Illustration & Parts List.
1		53845187	HOSE-3/4X24 12FS JIC 2500 PSI	1	
2		59410001	12M JICX12M ADJ. 90 DEG.ELBOW	1	
3		240334001	BOLT-1/2-13X1 3/4 GR8 ZINC PLT	2	
4		485025	WASHER-1/2 FLAT-HARDENED-ZINC	2	
5		296267035	GEAR PUMP	1	
5A		296267051	SEAL KIT	1	
6		70006001	FITTING-20M X 20 M JIC STR.	1	
7		296016001	HOSE-HYD-1X36.0-16FSJ ST/ST 200PSI	1	
8		296267049	O-RING	1	
9		296267034	GEAR PUMP	1	
9A		296267050	SEAL KIT	1	
10		296267044	O-RING	1	
11		296267041	CAP SCREW	2	
12		296267042	WASHER	2	
13		60907001	FITTING-16M JICX16M STR ADAPT	1	
14		53837001	FITTING - 8M O-RING X 8M JIC 90 DEGREE	1	
15		296258414	HOSE - 1.25 X 47 20FS ST/ST G4H	1	
16		296056001	HOSE-HYD-.50 X 366 8FSJ ST90 3000PSI	1	

Hyd-Pump-Heat/Cool/Filter Assy Fig 5-6

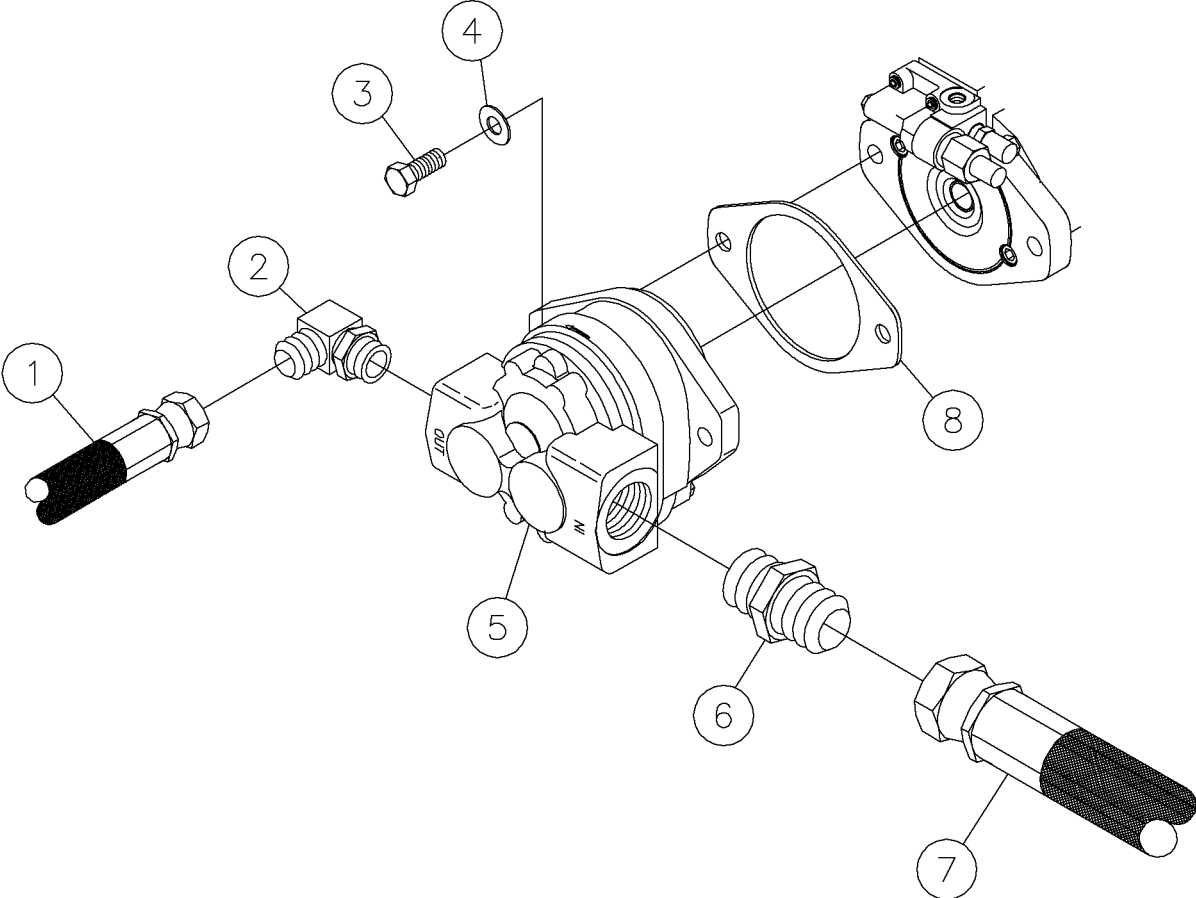

Hyd-Pump-Heat/Cool/Filter Assy Fig 5-6

REF. NO.	*	PART NO.	DESCRIPTION	QTY.	REMARKS
1		53845187	HOSE-3/4X24 12FS JIC 2500 PSI	1	
2		59410001	12M JICX12M ADJ. 90 DEG.ELBOW	1	
3		240334001	BOLT-1/2-13X1 3/4 GR8 ZINC PLT	2	
4		485025	WASHER-1/2 FLAT-HARDENED-ZINC	2	
5		296264804	PUMP - HYD 2.33 GEAR	1	
6		70006001	FITTING-20M X 20 M JIC STR.	1	
7		296258414	HOSE - 1.25 X 38 20C62 ST/ST G4H	1	
8		103032001	GASKET	1	

Hyd-Pump-Pressure Compensator Assy Fig 5-7r02

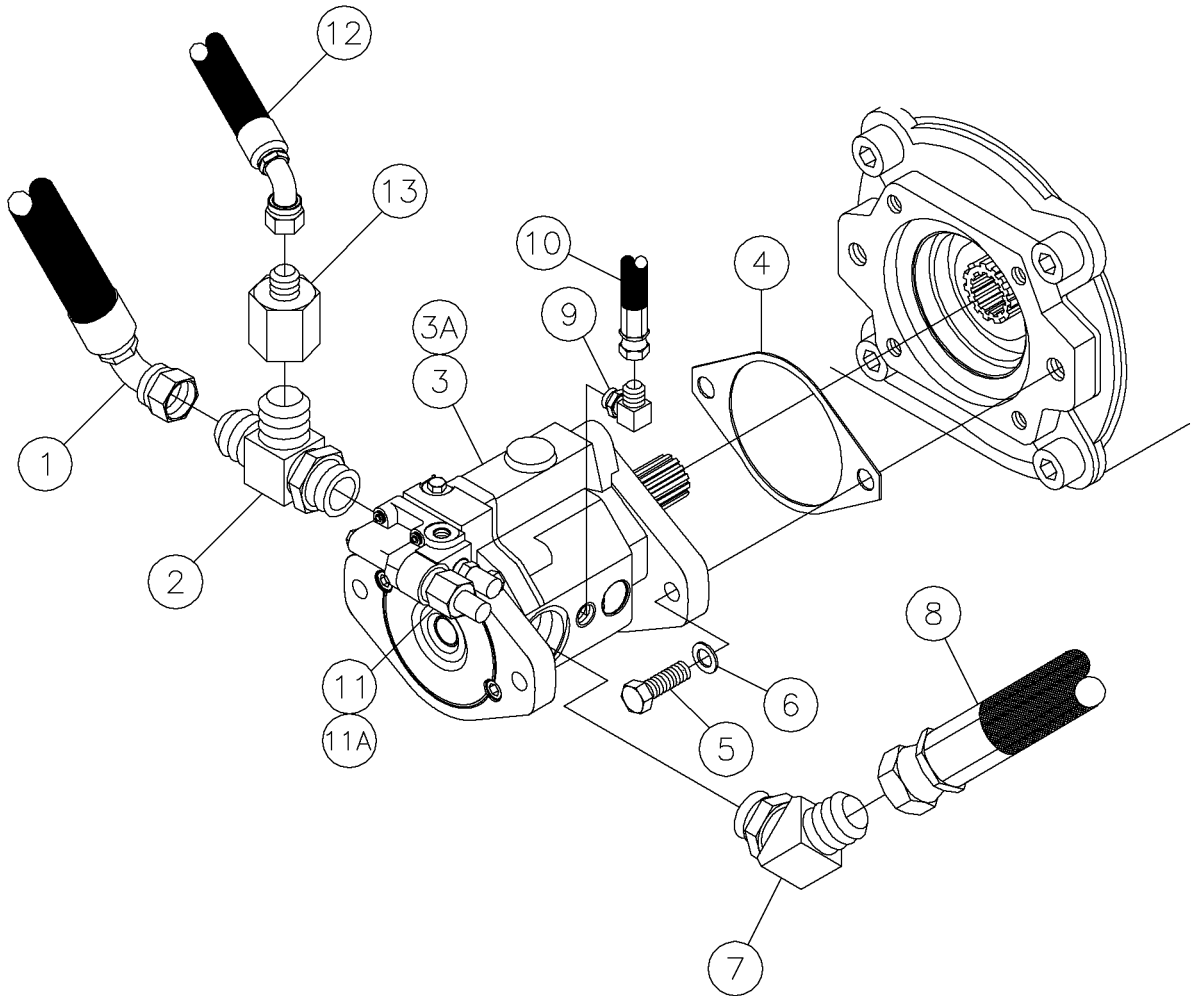

Hyd-Pump-Pressure Compensator Assy Fig 5-7r02

REF. NO.	*	PART NO.	DESCRIPTION	QTY.	REMARKS
		Revision Date	October, 2004		Update In Illustration & Parts List.
1		296256875	HOSE - 1.00 X 101 16 FS JIC MEGA ST/45 G6K	1	
2		94565001	TEE-16MJICX16MOR RUNX16MJIC	1	
3		296264803	PUMP - HYD 2.77 PC	1	
		77958097	SEAL KIT-PUMP & COMPENSATOR	1	
4		103032001	GASKET	1	
5		235737001	BOLT-1/2-13X1 1/4 GR8 ZINC PLT	2	
6		485025	WASHER-1/2 FLAT-HARDENED-YZ	2	
7		70006001	FITTING-20M X 20 M JIC STR.	1	
8		296258413	HOSE - 1.25 X 47 20FS ST/ST G4H	1	
9		59426001	FITTING - 90-6MJ-6MORBA	1	
10		57940695	HOSE-3/8X36 6FSJICST 3000# MTF	1	
11		296263368	COMPENSATOR	1	
		255052081	GASKET	1	
12		296266459	HOSE-0.5X16 8FJ ST/45 3000PSI 8M3K	1	
13		81581001	FITTING-8MX16F REDUCER	1	

Hyd-Pump-Pressure Compensator Assy Fig 5-7r01

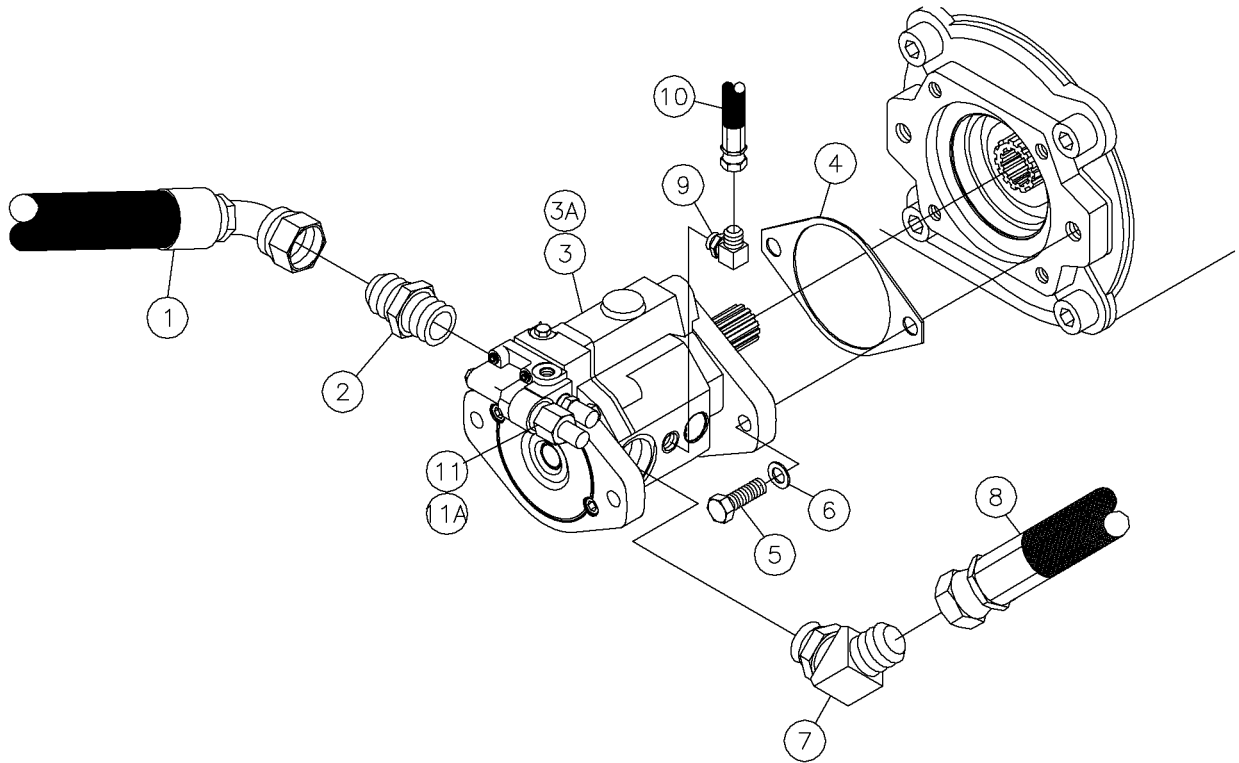

Hyd-Pump-Pressure Compensator Assy Fig 5-7r01

REF. NO.	*	PART NO.	DESCRIPTION	QTY.	REMARKS
		Revision Date	June, 2002		Update In Illustration & Parts List.
1		296256875	HOSE - 1.00 X 101 16 FS JIC MEGA ST/ 45 G6K	1	
2		60907001	FITTING-16M JICX16M STR ADAPT	1	
3		296264803	PUMP -HYD 2.77 PC	1	
3A		77958097	SEAL KIT-PUMP & COMPENSATOR	1	
4		103032001	GASKET	1	
5		235737001	BOLT-1/2-13X1 1/4 GR8 ZINC PLT	2	
6		485025	WASHER-1/2 FLAT-HARDENED-ZINC	2	
7		70006001	FITTING-20M X 20 M JIC STR.	1	
8		296258413	HOSE - 1.25 X 47 20C62 ST/ST G4H	1	
9		59426001	FITTING - 6M JIC X 6M O-RING ADJ 90 ELBOW	1	
10		57940695	HOSE-3/8X36 6FSJICST 3000# MTF	1	
11		296263368	COMPENSATOR	1	
11A		255052081	GASKET	1	

Hyd-Pump-Pressure Compensator Assy Fig 5-7

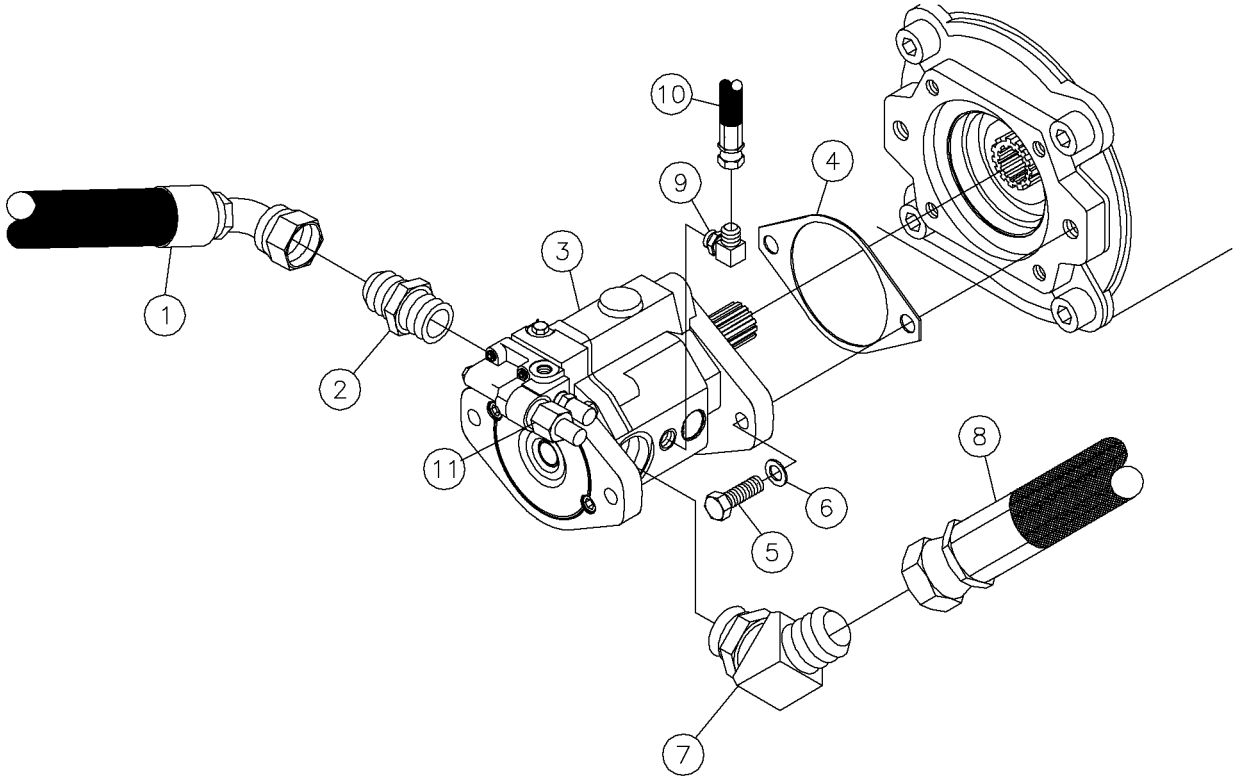

Hyd-Pump-Pressure Compensator Assy Fig 5-7

REF. NO.	*	PART NO.	DESCRIPTION	QTY.	REMARKS
1		296256875	HOSE - 1.00 X 101 16 FS JIC MEGA ST/45 G6K	1	
2		60907001	FITTING-16M JICX16M STR ADAPT	1	
3		296264803	PUMP -HYD 2.77 PC	1	
4		103032001	GASKET	1	
5		235737001	BOLT-1/2-13X1 1/4 GR8 ZINC PLT	2	
6		485025	WASHER-1/2 FLAT-HARDENED-ZINC	2	
7		81703001	FITTING-20MX20M JIC 45 DEG.EL.	1	
8		296258413	HOSE - 1.25 X 47 20C62 ST/ST G4H	1	
9		59426001	FITTING - 6M JIC X 6M O-RING ADJ 90 ELBOW	1	
10		57940695	HOSE-3/8X36 6FSJICST 3000# MTF	1	
11		296263368	COMPENSATOR	1	

Hyd-Motor-Track Drive Assy Fig 5-8r01

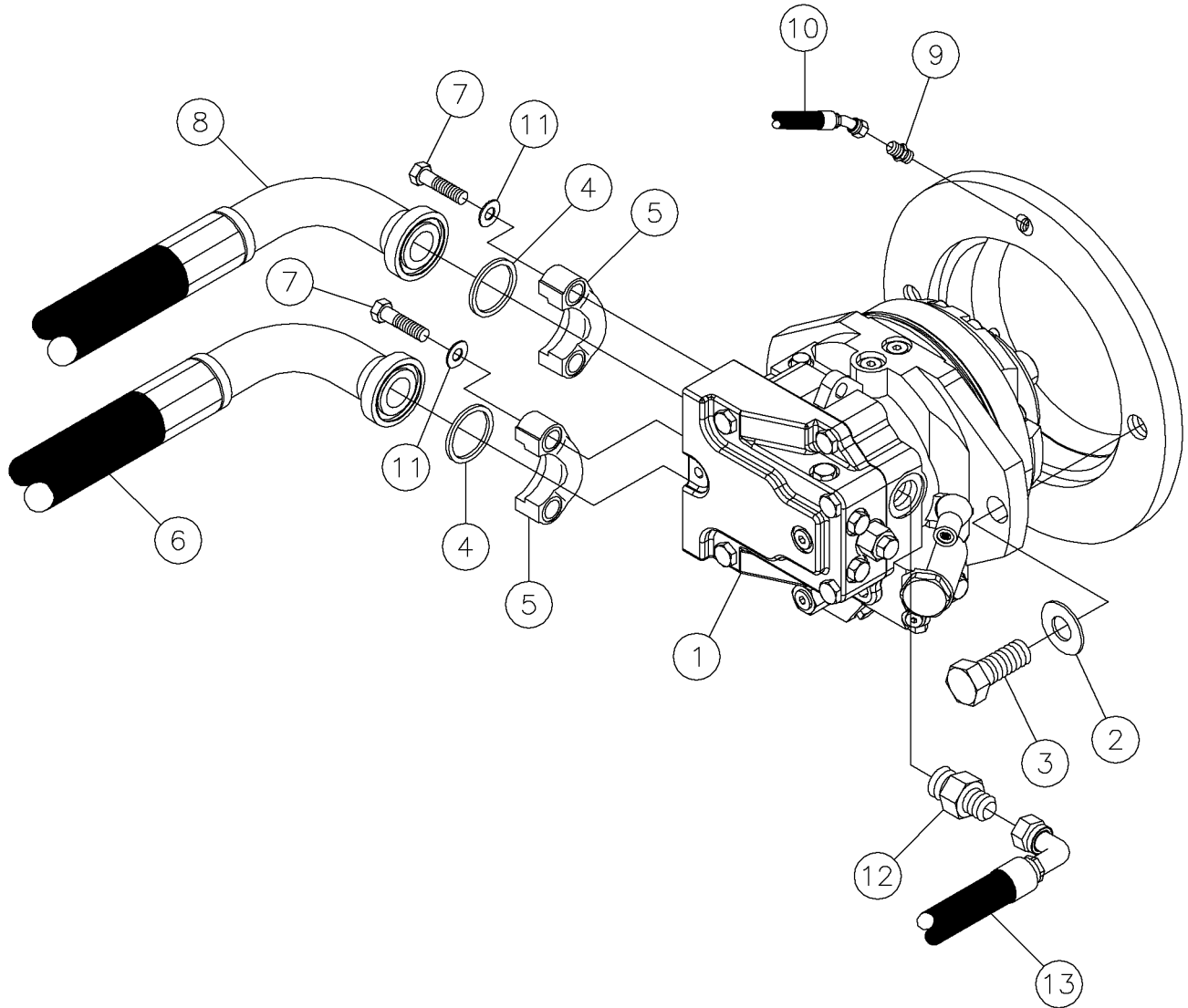

Hyd-Motor-Track Drive Assy Fig 5-8r01

REF. NO.	*	PART NO.	DESCRIPTION	QTY.	REMARKS
		Revision Date	October, 2004		Update In Illustration & Parts List.
1		615876001	MOTOR- SUNDSTRAND	1	
		114282003	SEAL CARRIER	1	
		114282005	LIP SEAL	1	
		114282007	O-RING	1	
		307469001	O-RING	1	
2		235717001	WASHER-3/4 FLAT HARDENED YELLOW ZINC	2	
3		102989001	BOLT-M20X1.5X45MM BN65 GR8.8	2	
4		72895001	O RING-SQ. #16 FLANGE	2	
5		67745001	FITTING - FLGH - 16CD62	4	
6		296258320	HOSE-HYD-1 X 37 16C62/16FS MEGA 90/90G6K	1	
7		381020	BOLT-7/16-14X2 GRADE 8 HEX	8	
8		296258319	HOSE-HYD-1 X 36 16C62/16FS MEGA 90/90G6K	1	
9		103058001	FITTING-M12X1.5X4M JIC STR.	1	
10		53843357	HOSE-1/4X33 4FS JIC 3000 PSI	1	
11		250515001	7/16 HARD WASHER SAE Y/ZINC	8	
12		53854001	12M O-RING-10M JIC ST.	1	
13		53842491	HOSE 5/8X45 10FSJICST/90D3000#	1	

Hyd-Motor-Track Drive Assy Fig 5-8

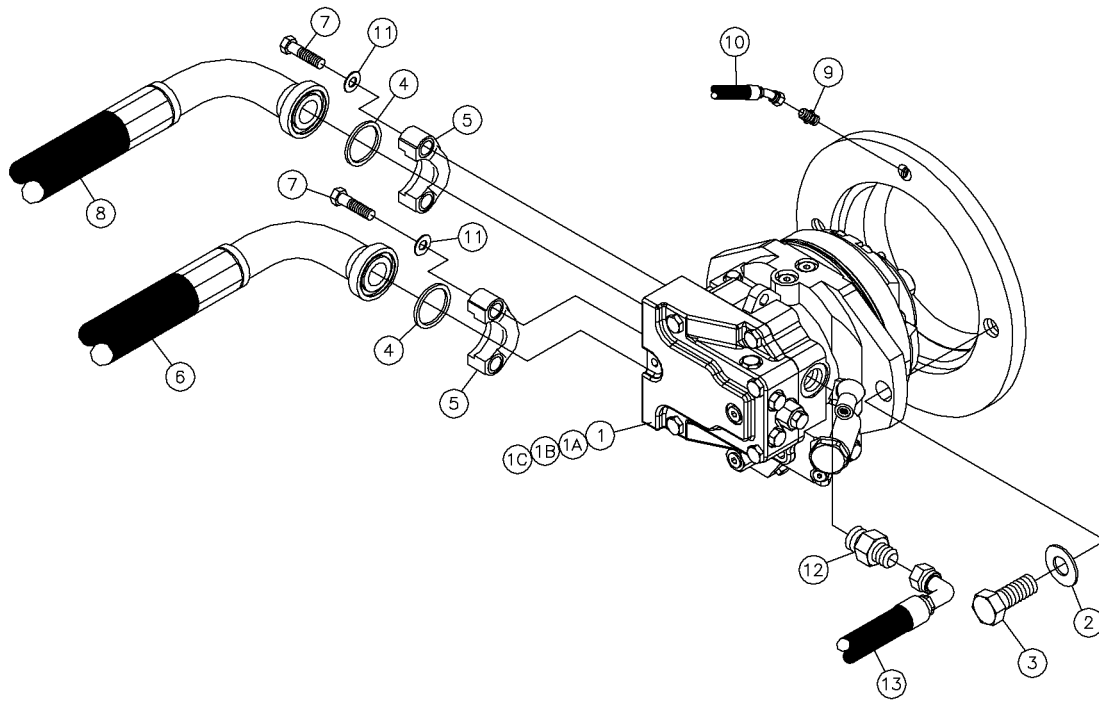

Hyd-Motor-Track Drive Assy Fig 5-8

REF. NO.	*	PART NO.	DESCRIPTION	QTY.	REMARKS
1		114282001	MOTOR- SUNDSTRAND	1	
1A		114282003	SEAL CARRIER	1	
1B		114282005	LIP SEAL	1	
1C		114282007	O-RING	1	
2		235717001	WASHER-3/4 FLAT HARDENED YELLOW ZINC	2	
3		102989001	BOLT-M20X1.5X45MM BN65 GR8.8	2	
4		72895001	O RING-SQ. #16 FLANGE	2	
5		67745001	SPLIT FLANGE HALF CODE 62/16	4	
6		296258320	HOSE -HYD-1 X 37 16CD6290 - 16FSJ90	1	
7		510303020	SCREW-HCS-.44-14X2.00-GR5-YZ	8	
8		296258319	HOSE-HYD-1X36 16CD6290-16FSJ90	1	
9		103058001	FITTING-M12X1.5X4M JIC STR.	1	
10		53843357	HOSE-1/4X33 4FS JIC 3000 PSI	1	
11		250515001	7/16 HARD WASHER SAE Y/ZINC	8	
12		53854001	FITTING-12M O-RING-10M JIC ST.	1	
13		53842491	HOSE 5/8X45 10FSJICST/90D3000#	1	

Hyd-Motor-Track Drive Assy Fig 5-9r02

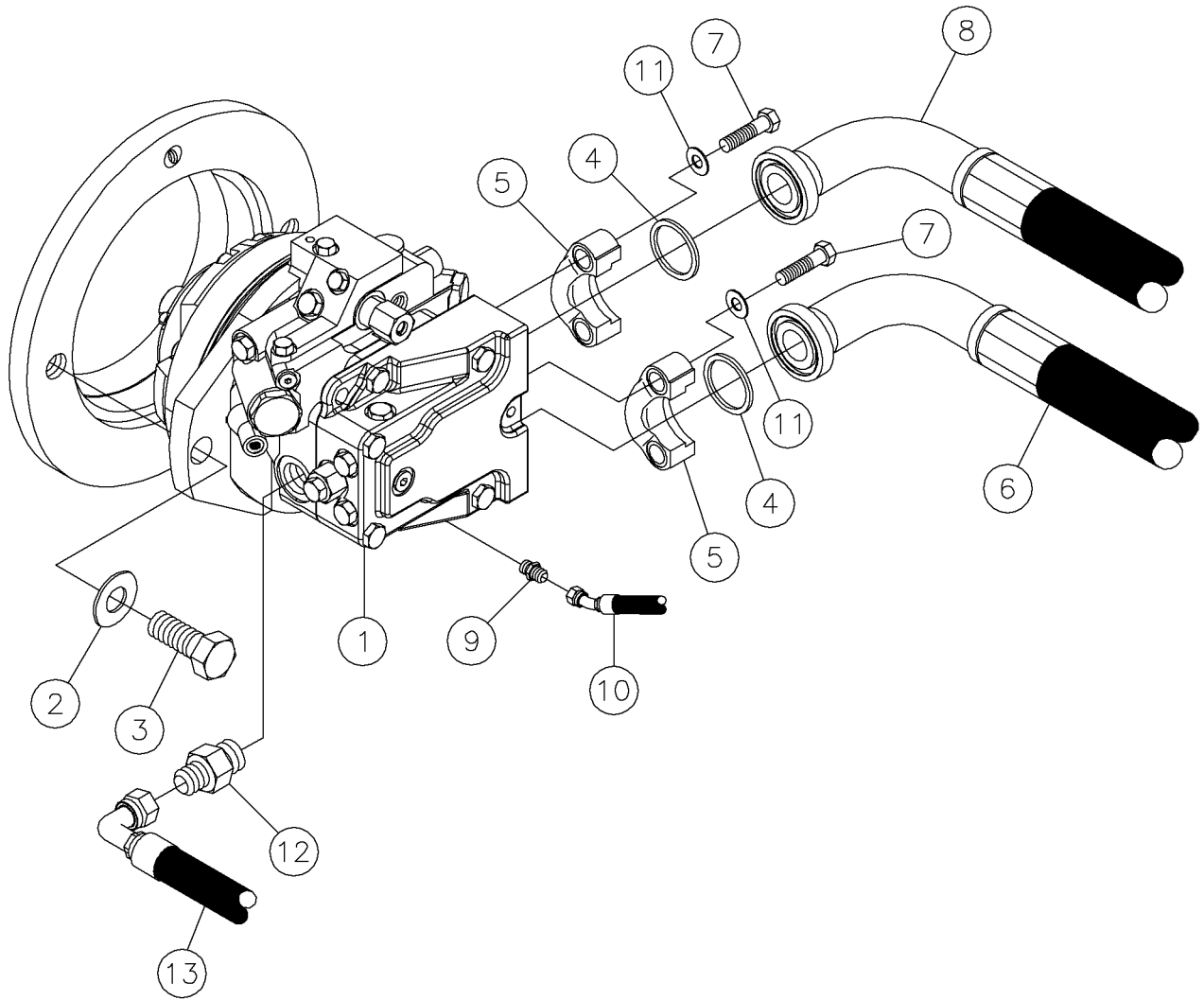

Hyd-Motor-Track Drive Assy Fig 5-9r02

REF. NO.	*	PART NO.	DESCRIPTION	QTY.	REMARKS
		Revision Date	October, 2004		Update In Illustration & Parts List.
1		615876001	MOTOR- SUNDSTRAND	1	
		114282003	SEAL CARRIER	1	
		114282005	LIP SEAL	1	
		114282007	O-RING	1	
		307469001	O-RING	1	
2		235717001	WASHER-3/4 FLAT HARDENED YELLOW ZINC	2	
3		102989001	BOLT-M20X1.5X45MM BN65 GR8.8	2	
4		72895001	O RING-SQ. #16 FLANGE	2	
5		67745001	FITTING - FLGH - 16CD62	4	
6		296258321	HOSE-HYD-1 X 22 16C62/16FS MEGA 90/90G6K	1	
7		381020	BOLT-7/16-14X2 GRADE 8 HEX	8	
8		296258322	HOSE-HYD-1X70 16C62/16FS MEGA 90/90G6K	1	
9		103058001	FITTING-M12X1.5X4M JIC STR.	1	
10		242688001	HOSE-1/4X47 4FS JIC (M3KMTF)	1	
11		250515001	7/16 HARD WASHER SAE Y/ZINC	8	
12		53854001	12M O-RING-10M JIC ST.	1	
13		296256879	HOSE - .625 X 57 10 FS JIC 90/ST M3K	1	

Hyd-Motor-Track Drive Assy Fig 5-9r01

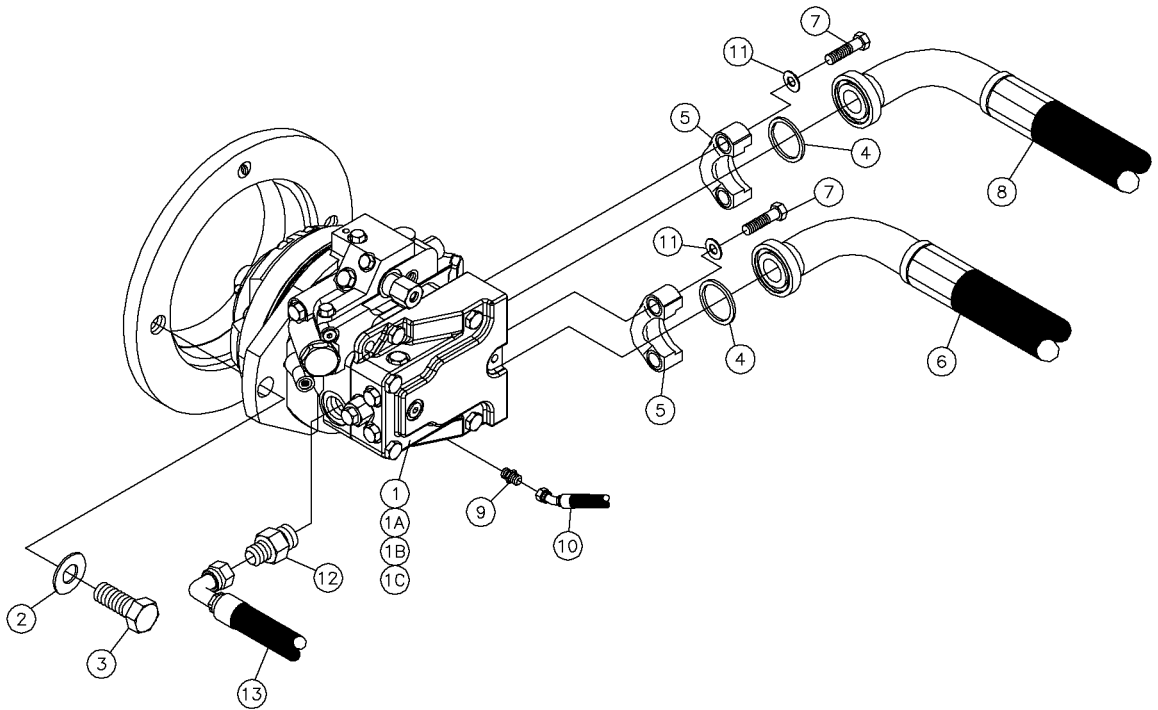

Hyd-Motor-Track Drive Assy Fig 5-9r01

REF. NO.	*	PART NO.	DESCRIPTION	QTY.	REMARKS
		Revision Date	June, 2002		Correct Hose
1		114282001	MOTOR-SUNDSTRAND 4.57 CU.IN.	1	
1A		114282003	SEAL CARRIER	1	
1B		114282005	LIP SEAL	1	
1C		114282007	O-RING	1	
2		235717001	WASHER-3/4 FLAT HARDENED YELLOW ZINC	2	
3		102989001	BOLT-M20X1.5X45MM BN65 GR8.8	2	
4		72895001	O RING-SQ. #16 FLANGE	2	
5		67745001	SPLIT FLANGE HALF CODE 62/16	4	
6		296258321	HOSE -HYD-1 X 22 16CD6290 - 16FSJ90	1	
7		510303020	SCREW-HCS-.44-14X2.00-GR5-YZ	8	
8		296258322	HOSE -HYD-1 X 70 16CD6260 - 16FSJ90	1	
9		103058001	FITTING-M12X1.5X4M JIC STR.	1	
10	*	242688001	HOSE-1/4X47 4FS JIC (M3KMTF)	1	
11		250515001	7/16 HARD WASHER SAE Y/ZINC	8	
12		53854001	FITTING-12M O-RING-10M JIC ST.	1	
13		296256879	HOSE - .625 X 57 10 FS JIC 90/ST M3K	1	

Hyd-Motor-Track Drive Assy Fig 5-9

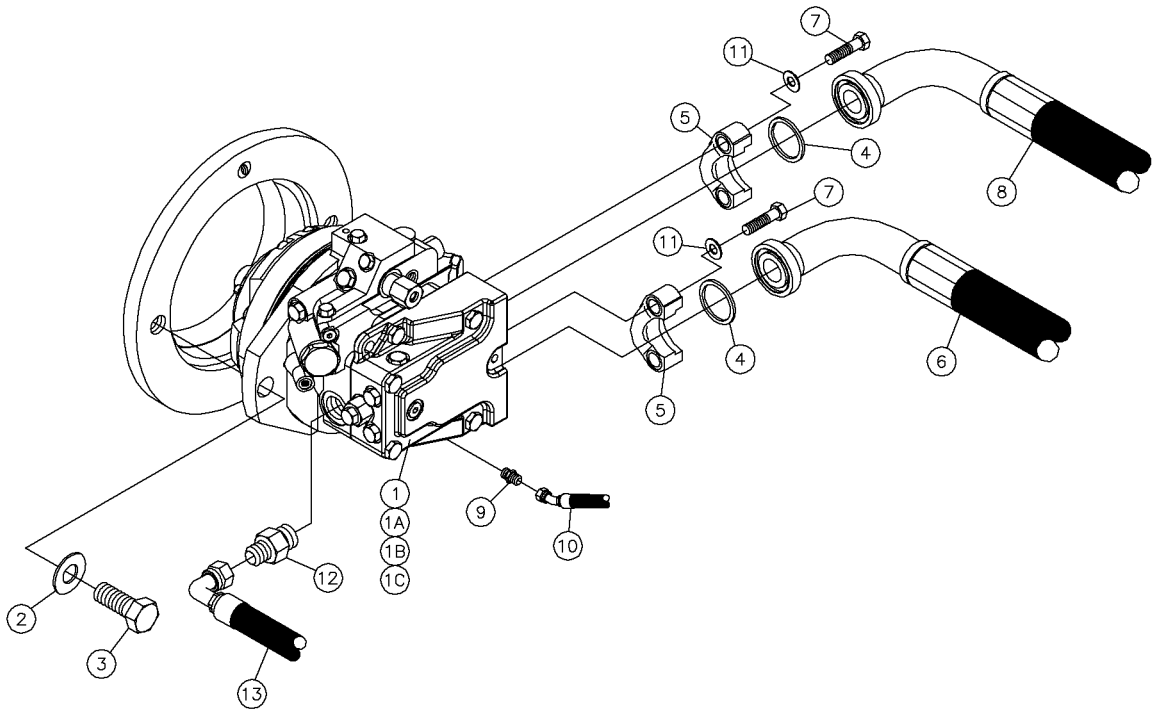

Hyd-Motor-Track Drive Assy Fig 5-9

REF. NO.	*	PART NO.	DESCRIPTION	QTY.	REMARKS
1		114282001	MOTOR-SUNDSTRAND 4.57 CU.IN.	1	
1A		114282003	SEAL CARRIER	1	
1B		114282005	LIP SEAL	1	
1C		114282007	O-RING	1	
2		235717001	WASHER-3/4 FLAT HARDENED YELLOW ZINC	2	
3		102989001	BOLT-M20X1.5X45MM BN65 GR8.8	2	
4		72895001	O RING-SQ. #16 FLANGE	2	
5		67745001	SPLIT FLANGE HALF CODE 62/16	4	
6		296258321	HOSE -HYD-1 X 22 16CD6290 - 16FSJ90	1	
7		510303020	SCREW-HCS-.44-14X2.00-GR5-YZ	8	
8		296258322	HOSE -HYD-1 X 70 16CD6260 - 16FSJ90	1	
9		103058001	FITTING-M12X1.5X4M JIC STR.	1	
10		269256901	HOSE - .25 X 47 4 FS JIC ST/45 M3K	1	
11		250515001	7/16 HARD WASHER SAE Y/ZINC	8	
12		53854001	FITTING-12M O-RING-10M JIC ST.	1	
13		296256879	HOSE - .625 X 57 10 FS JIC 90/ST M3K	1	

Hyd-Motor-Fan Drive Assy Fig 5-10

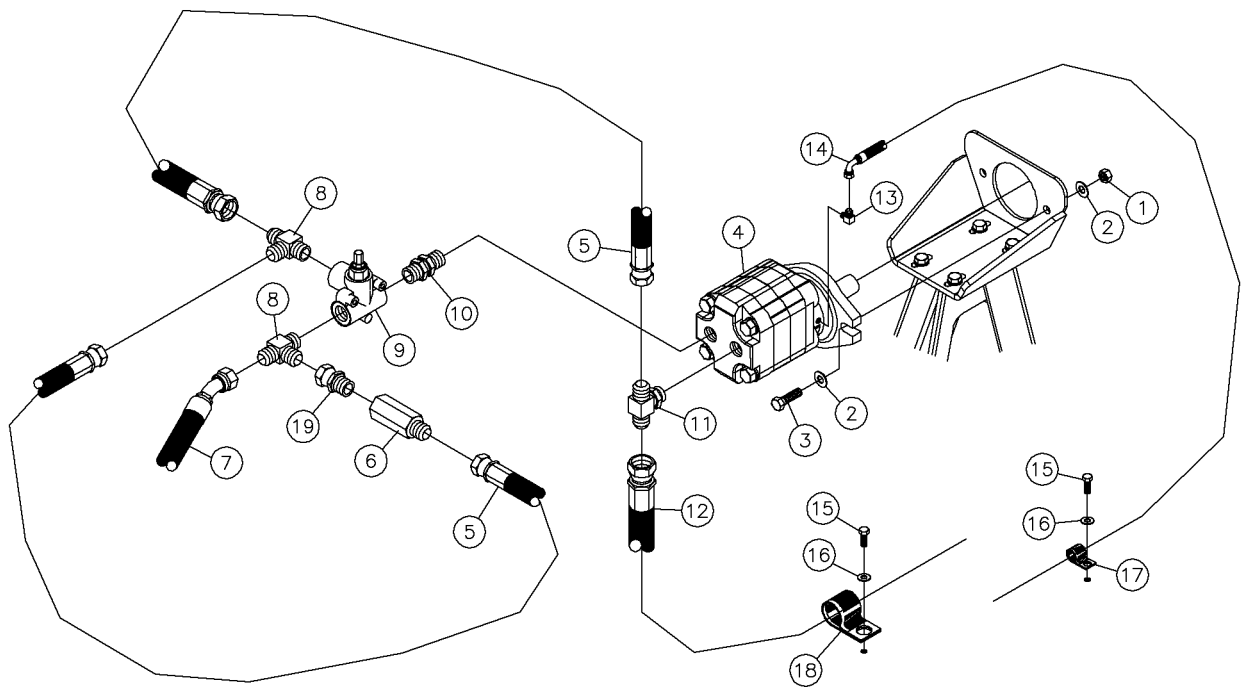

Hyd-Motor-Fan Drive Assy Fig 5-10

REF. NO.	*	PART NO.	DESCRIPTION	QTY.	REMARKS
1		235731001	NUT-1/2-13 GR8 ZINC PLTD	2	
2		485025	WASHER-1/2 FLAT-HARDENED-ZINC	4	
3		235721001	BOLT-1/2-13X1 1/2 GR8 ZINC PLT	2	
4		288986001	MOTOR 3.2 CIR B-FACE 1.25 SHAFT HYD	1	
5		53845731	HOSE-3/4X30 12FS JIC META 3000	2	
6		204246001	VALVE-CHECK 3000 PSI	1	
7		296261567	HOSE - HYD - .25 X 41.00 - 12FSJ - ST/45 -3000PSI	1	
8		59420001	12 JICX12M ADJ. STR THRD TEE	2	
9		224753001	VALVE-RELIEF RV SERIES	1	Breakdown Fig 12-2
10		712001	12 M HEX NIPPLE	1	
11		70032001	FITTING-12M BCH X 12M JICX12M JIC TEE	1	
12		53845307	HOSE-3/4X70 12FS JIC 3000 PSI	1	
13		56647001	FITTING-1/4MX4M JIC 90 DEG.	1	
14		296261579	HOSE-HYD-.25X186-4FSJ-90/ST-3000PSI	1	
15		235727001	BOLT-3/8-16X1 GR8 HEX ZINC PLT	4	
16		235713001	WASHER-3/8 SAE HARD ZINC PLTD	4	
17		2595007	HOSE CLAMP - TS7J 3/4"	2	
18		2595013	CLAMP-1"HOSE W/VINYL COAT	2	
19		85664001	FITTING-12M X 12FS JIC STR	1	

Hyd-Motor-Rotation Drive Assy Fig 5-11

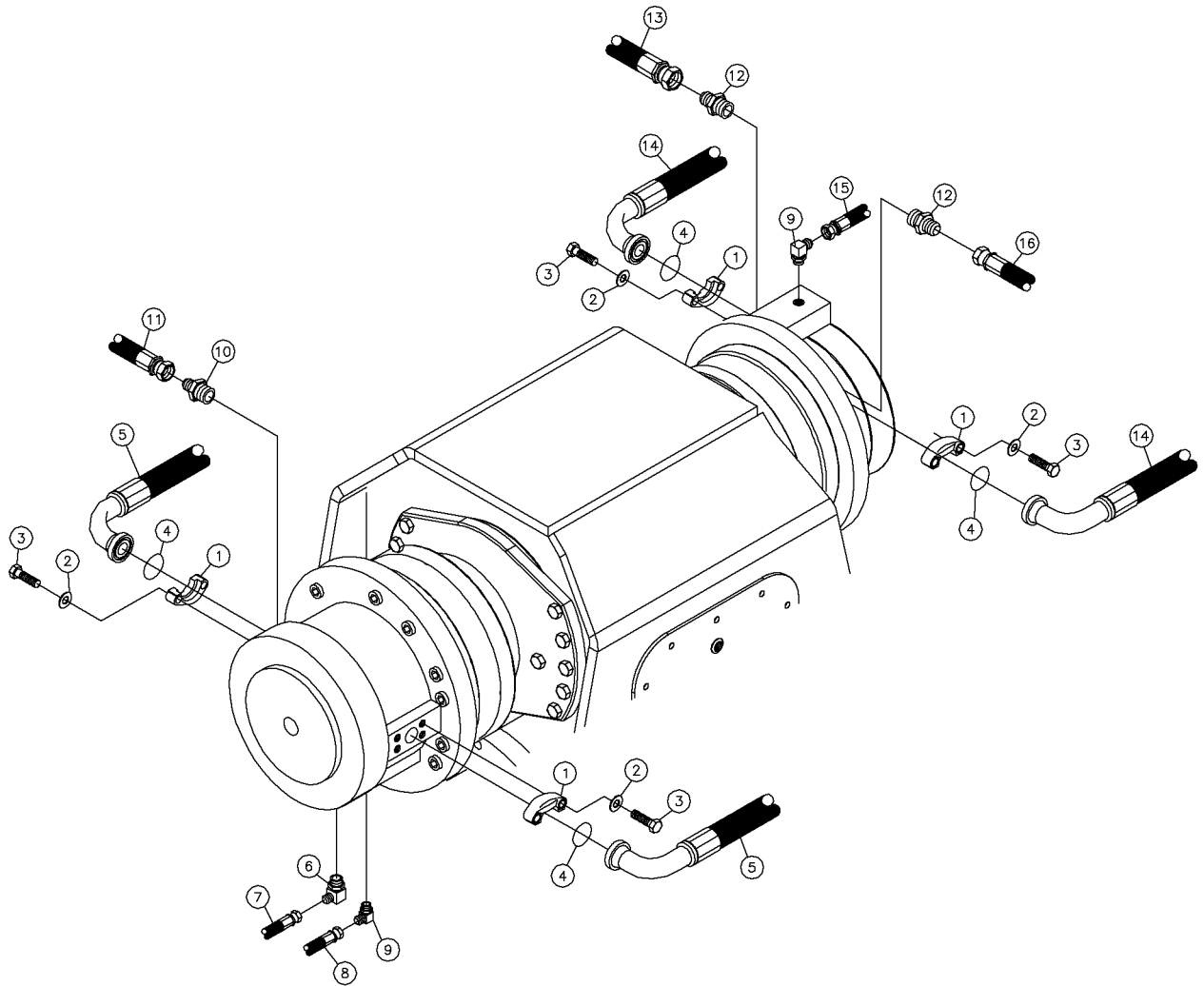

Hyd-Motor-Rotation Drive Assy Fig 5-11

REF. NO.	*	PART NO.	DESCRIPTION	QTY.	REMARKS
1		67745001	SPLIT FLANGE HALF CODE 62/16	8	
2		508486012	WASHER-FLAT, HARDENED,M12, YZ, DIN6916	16	
3		507093045	SCREW-HCS,M12- 1.75X45,8.8,YZ,ISO4017,FT	16	
4		72895001	O RING-SQ. #16 FLANGE	8	
5		296258397	HOSE - 1.00 X 73 16C62/16FS JICM 90L/ ST G6K	2	
6		57954001	FITTING-8M X 6M JIC 90 DEGS	1	
7		296256872	HOSE - .375 X 540 6FS JIC ST/ST M3K	1	
8		57940543	HOSE-3/8X70 6FS 3000 PSI	1	
9		59426001	FITTING - 6M JIC X 6M O-RING ADJ 90 ELBOW	2	
10		81930001	FITTING-8MX12M JIC STR.	2	
11		53844249	HOSE-1/2X28 8FS JIC 3000 PSI	1	
12		53854001	12M O-RING-10M JIC ST.	1	
13		256007001	HOSE-5/8 X 39 10FS JIC ST/90 3000 PSI	1	
14		296258399	HOSE - 1.00 X 40 16C62/16FS MEGA 90/ ST G6K	1	
15		57940739	HOSE-3/8X27 6FS JIC 3000 PSI	1	
16		296256881	HOSE - .50 X 26 8FS JIC ST/ST M3K	1	

Hyd-Motor-Thrust/Pullback Drive Assy(LF) Fig 5-12r01

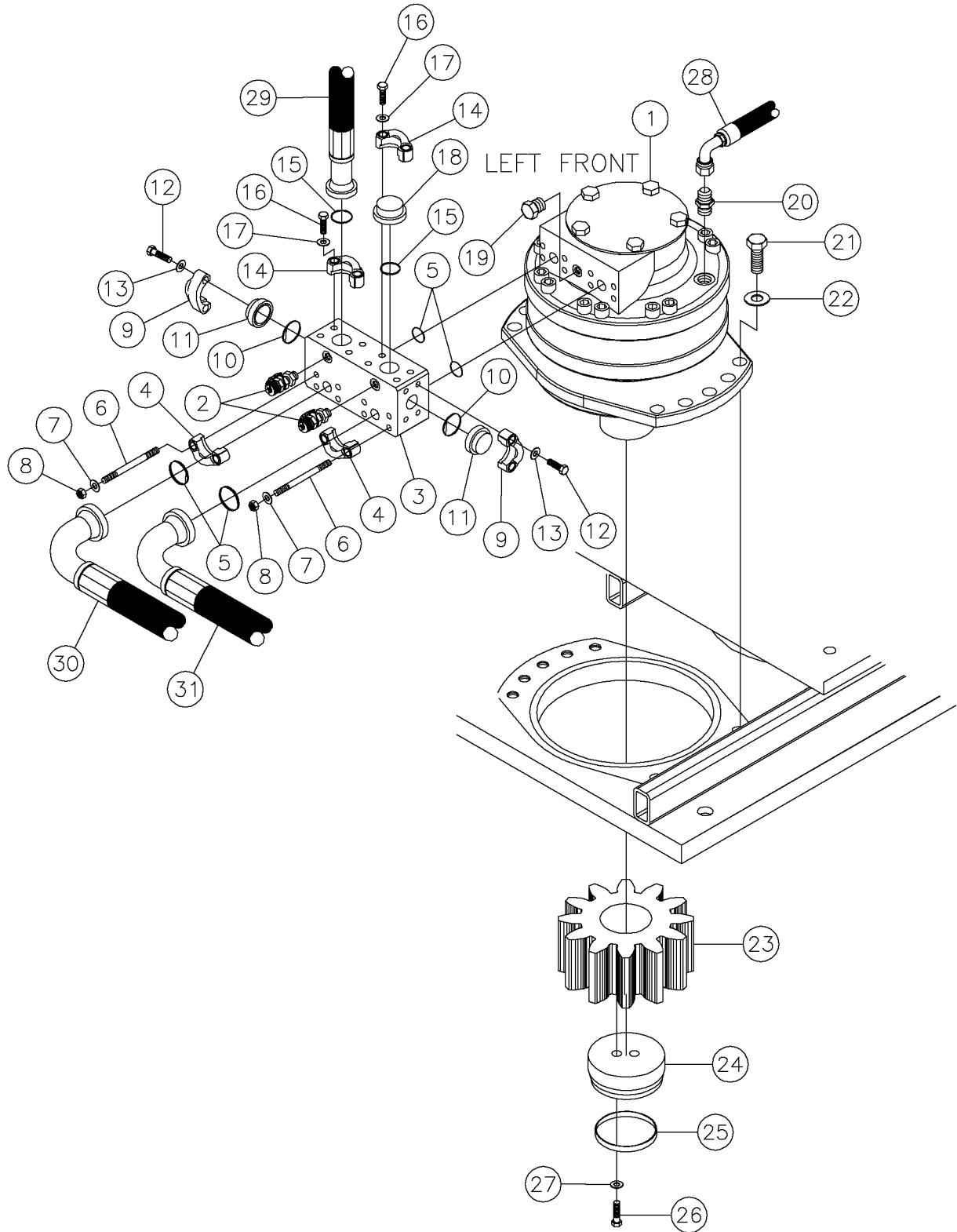

Hyd-Motor-Thrust/Pullback Drive Assy(LF) Fig 5-12r01

REF. NO.	*	PART NO.	DESCRIPTION	QTY.	REMARKS
		Revision Date	October, 2004		Update In Illustration & Parts List.
1		277955001	MOTOR-MS18-2-117-A18-2A10-5000	1	Breakdown Fig 12-36
2		75493001	FITTING - TEST - 4MORB - 16MTP	2	
3		296261719	MANIFOLD - MS 18 MOTOR	1	
4		67746001	FITTING - FLGH - 12CD62	4	
5		72894001	O RING-SQ. #12 FLANGE	4	
6		296261742	THREADED STUD - M10 X 1.5 X 125	8	
7		233497001	WASHER-10.7X21X2.5MM HARD FLT	8	
8		61656001	NUT-HEX M10-1.50 CL8 YZ D934	8	
9		67745001	FITTING - FLGH - 16CD62	4	
10		72895001	O RING-SQ. #16 FLANGE	2	
11		296261741	FITTING - PLUG - 16 - FLGH	2	
12		250507001	BOLT 7/16-14 X 1 3/4"GR8 HEX Y	8	
13		510335709	WASHER-LOCK-.44-.46X.78-.11-YZ	8	
14		78060001	FLANGE- 20 CODE 62	4	
15		72896001	O RING-SQ. #20 FLANGE	2	
16		235718001	BOLT-1/2-13X2 GR8 HEX ZINC PLT	8	
17		485025	WASHER-1/2 FLAT-HARDENED-YZ	8	
18		296261740	FITTING-PLUG-20-FLGH	1	
19		4235001	FITTING - PLUG - 10MORB - HEX	1	
20		53827001	FITT.-#10M O-RING-#10M JIC ST.	1	
21		296258304	SCREW - HCS .875 - 9 X2,GR8,YZ	10	
22		288459001	WASHER - 7/8 FLAT HARD ZINC PLATED	10	
23		277852001	PINION - 16 MODUEL - 12T- 4" FACE	1	
24		288498001	CAP - PPU MOUNT	1	
25		234814001	60 PULSE RING	1	
26		507094070	SCREW-HCS,M14- 2.00X70,8.8,YZ,ISO4014,PT	2	
27		506046014	WASHER-FLAT,M14,YZ,D125A	2	
28		296258362	HOSE - .63 X 29 10FS JIC 90/90 M3K	1	
29		296256883	HOSE - HYD -1.00-42-16C62-90/ST-G6K	1	
30		296258405	HOSE - 1.00 X 24 12C62 90/90 G6K	1	
31		296258406	HOSE - 1.00 X 13.50 12C62 90/90 G6K	1	

Hyd-Motor-Thrust/Pullback Drive Assy(RF) Fig 5-12x01

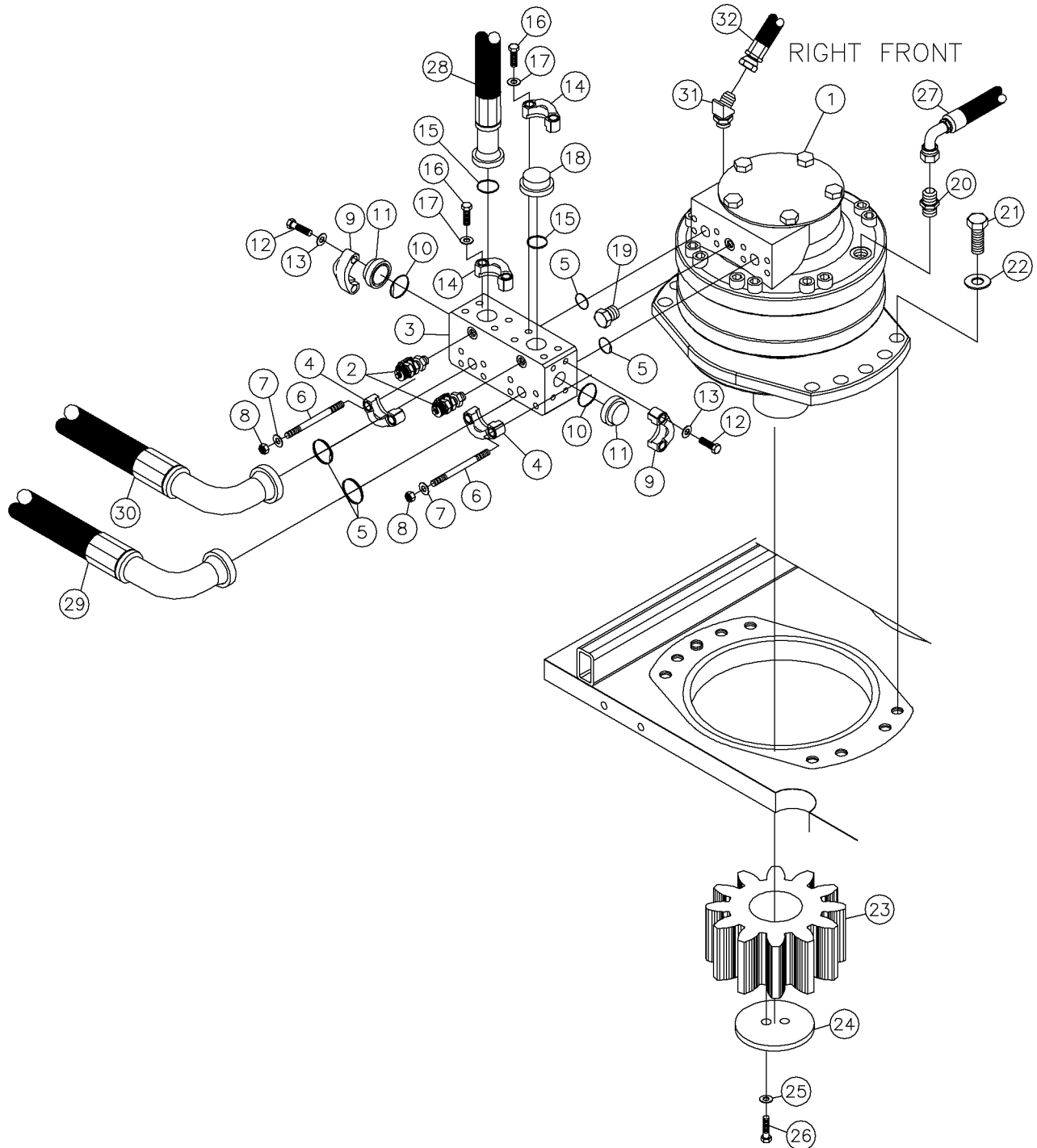

Hyd-Motor-Thrust/Pullback Drive Assy(RF) Fig 5-12x01

REF. NO.	*	PART NO.	DESCRIPTION	QTY.	REMARKS
		Revision Date	October, 2004		Update In Illustration & Parts List.
1		277955001	MOTOR-MS18-2-117-A18-2A10-5000	1	Breakdown Fig 12-36
2		75493001	FITTING - TEST - 4MORB - 16MTP	2	
3		296261719	MANIFOLD - MS 18 MOTOR	1	
4		67746001	FITTING - FLGH - 12CD62	4	
5		72894001	O RING-SQ. #12 FLANGE	4	
6		296261742	THREADED STUD - M10 X 1.5 X 125	8	
7		233497001	WASHER-10.7X21X2.5MM HARD FLT	8	
8		61656001	NUT-HEX M10-1.50 CL8 YZ D934	8	
9		67745001	FITTING - FLGH - 16CD62	4	
10		72895001	O RING-SQ. #16 FLANGE	2	
11		296261741	FITTING - PLUG - 16 - FLGH	2	
12		250507001	BOLT 7/16-14 X 1 3/4"GR8 HEX Y	8	
13		510335709	WASHER-LOCK-.44-.46X.78-.11-YZ	8	
14		78060001	FLANGE- 20 CODE 62	4	
15		72896001	O RING-SQ. #20 FLANGE	2	
16		235718001	BOLT-1/2-13X2 GR8 HEX ZINC PLT	8	
17		485025	WASHER-1/2 FLAT-HARDENED-YZ	8	
18		296261740	FITTING-PLUG-20-FLGH	1	
19		4235001	FITTING - PLUG - 10MORB - HEX	1	
20		53827001	FITT.-#10M O-RING-#10M JIC ST.	1	
21		296258304	SCREW - HCS .875 - 9 X2,GR8,YZ	10	
22		288459001	WASHER - 7/8 FLAT HARD ZINC PLATED	10	
23		277852001	PINION - 16 MODUEL - 12T- 4" FACE	1	
24		288454001	CAP - MS18 MOTOR	1	
25		506046014	WASHER-FLAT,M14,YZ,D125A	2	
26		507094070	SCREW-HCS,M14- 2.00X70,8.8,YZ,ISO4014,PT	2	
27		296258362	HOSE - .63 X 29 10FS JIC 90/90 M3K	1	
28		296256883	HOSE - HYD -1.00-42-16C62-90/ST-G6K	1	
29		296258405	HOSE - 1.00 X 24 12C62 90/90 G6K	1	
30		296258406	HOSE - 1.00 X 13.50 12C62 90/90 G6K	1	
31		56725001	FITTING-10MX10M JIC 45 DEG.	1	
32		296256884	HOSE - HYD-1.00-47-16C62-90/ST-G6K	1	

Hyd-Motor-Thrust/Pullback Drive Assy(LM) Fig 5-12x02

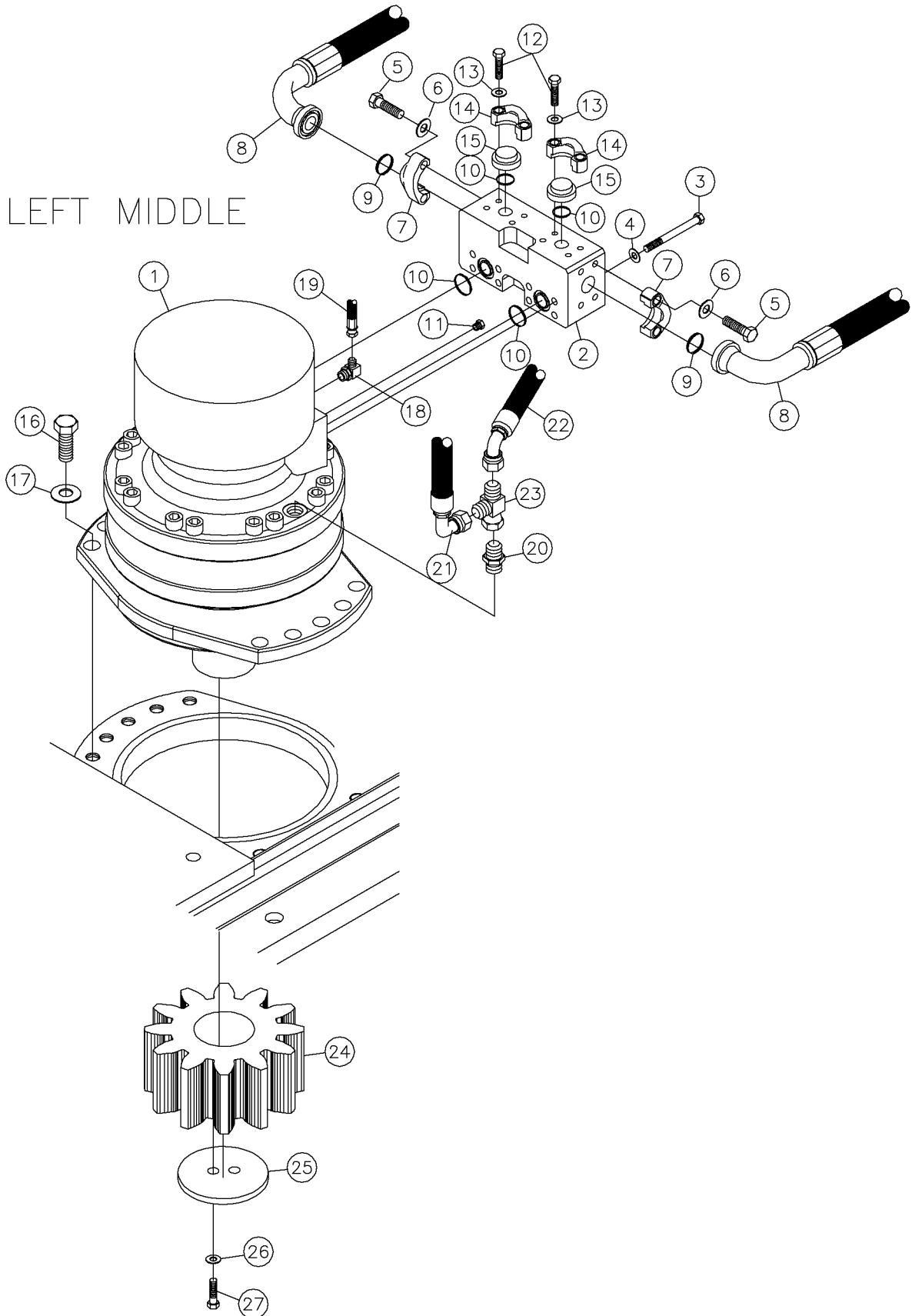

Hyd-Motor-Thrust/Pullback Drive Assy(LM) Fig 5-12x02

REF. NO.	*	PART NO.	DESCRIPTION	QTY.	REMARKS
		Revision Date	October, 2004		Addition To Manual
1		277956001	MOTOR-MS18-2-117-F19-2A10-5000	1	Breakdown Fig 12-35
2		296261717	MANIFOLD-MS 18 MOTOR	1	
3		249891001	BOLT-M10X35 10.9 HHCS D933 ZNC	8	
4		233497001	WASHER-10.7X21X2.5MM HARD FLT	8	
5		250507001	BOLT 7/16-14 X 1 3/4"GR8 HEX Y	8	
6		510335709	WASHER-LOCK-.44-.46X.78-.11-YZ	8	
7		67745001	FITTING - FLGH - 16CD62	4	
8		296267783	HOSE-HYD-1X14.25 16CD629OS/ 16CD629OS	2	
9		72895001	O RING-SQ. #16 FLANGE	2	
10		72894001	O RING-SQ. #12 FLANGE	4	
11		4235001	FITTING - PLUG - 10MORB - HEX	1	
12		235723001	SCREW - HCS -.38 - 16 X 1.50 - GR8 - YZ	8	
13		235713001	WASHER - FLATSTRL - .38 - .41 X .81 - .06-YA-A325	8	
14		67746001	FITTING - FLGH - 12CD62	4	
15		67746001	FITTING - FLGH - 12CD62	2	
16		296258304	SCREW - HCS .875 - 9 X2,GR8,YZ	10	
17		288459001	WASHER - 7/8 FLAT HARD ZINC PLATED	10	
18		57950001	FITTING-90-4MJ-6MORBA	1	
19		53843481	HOSE-1/4X60 4FS JIC 3000 PSI	1	
20		53827001	FITT.-#10M O-RING-#10M JIC ST.	1	
21		296029001	HOSE-HYD 5/8X50 10FSJ 90/90 3000PSI	1	
22		296028001	HOSE-HYD 5/8X22 10 FSJ ST/45 3000PSI	1	
23		100872001	FITTING-10FSJICX10MJIC RUN TEE	1	
24		277852001	PINION - 16 MODUEL - 12T- 4" FACE	1	
25		288454001	CAP - MS18 MOTOR	1	
26		506046014	WASHER-FLAT,M14,YZ,D125A	2	
27		507094035	SCREW-HCS,M14- 2.00X35,8.8,YZ,ISO4017,FT	2	

Hyd-Motor-Thrust/Pullback Drive Assy(RM) Fig 5-12x03

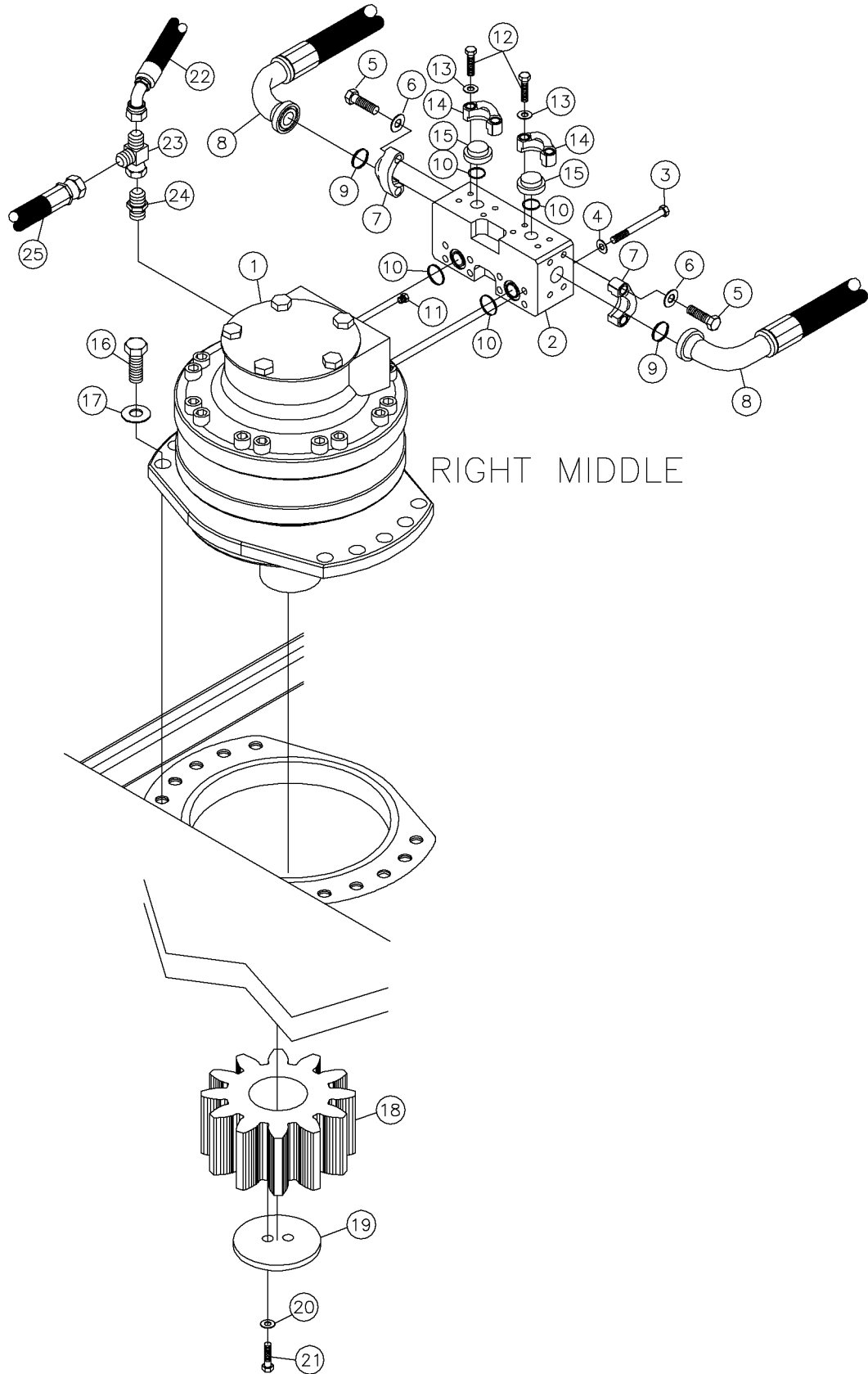

Hyd-Motor-Thrust/Pullback Drive Assy(RM) Fig 5-12x03

REF. NO.	*	PART NO.	DESCRIPTION	QTY.	REMARKS
		Revision Date	October, 2004		Addition To Manual
1		277956001	MOTOR-MS18-2-117-F19-2A10-5000	1	Breakdown Fig 12-36
2		296261717	MANIFOLD-MS 18 MOTOR	1	
3		249891001	BOLT-M10X35 10.9 HHCS D933 ZNC	8	
4		233497001	WASHER-10.7X21X2.5MM HARD FLT	8	
5		250507001	BOLT 7/16-14 X 1 3/4"GR8 HEX Y	8	
6		510335709	WASHER-LOCK-.44-.46X.78-.11-YZ	8	
7		67745001	FITTING - FLGH - 16CD62	4	
8		296267783	HOSE-HYD-1X14.25 16CD629OS/ 16CD629OS	2	
9		72895001	O RING-SQ. #16 FLANGE	2	
10		72894001	O RING-SQ. #12 FLANGE	4	
11		4235001	FITTING - PLUG - 10MORB - HEX	1	
12		235723001	SCREW - HCS -.38 - 16 X 1.50 - GR8 - YZ	8	
13		235713001	WASHER - FLATSTRL - .38 - .41 X .81 - .06-YA-A325	8	
14		67746001	FITTING - FLGH - 12CD62	4	
15		67746001	FITTING - FLGH - 12CD62	2	
16		296258304	SCREW - HCS .875 - 9 X2,GR8,YZ	10	
17		288459001	WASHER - 7/8 FLAT HARD ZINC PLATED	10	
18		277852001	PINION - 16 MODUEL - 12T- 4" FACE	1	
19		288454001	CAP - MS18 MOTOR	1	
20		506046014	WASHER-FLAT,M14,YZ,D125A	2	
21		507094035	SCREW-HCS,M14- 2.00X35,8.8,YZ,ISO4017,FT	2	
22		296028001	HOSE-HYD 5/8X22 10 FSJ ST/45 3000PSI	1	
23		100872001	FITTING-10FSJICX10MJIC RUN TEE	1	
24		53827001	FITT.-#10M O-RING-#10M JIC ST.	1	
25		296258363	HOSE - .63 X 30 10FS JIC ST/45 M3K	1	

Hyd-Motor-Thrust/Pullback Drive Assy(LR) Fig 5-12x04

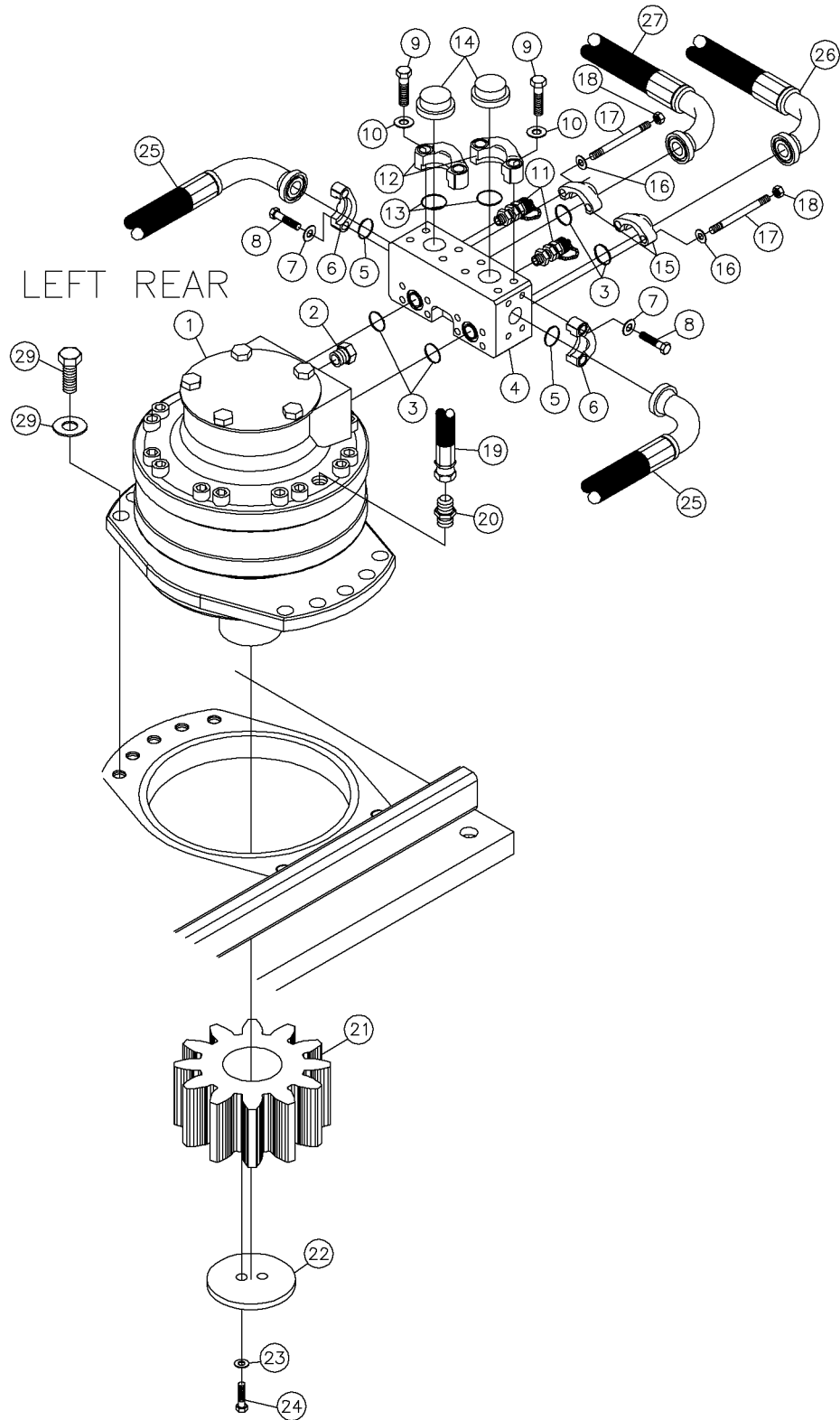

Hyd-Motor-Thrust/Pullback Drive Assy(LR) Fig 5-12x04

REF. NO.	*	PART NO.	DESCRIPTION	QTY.	REMARKS
		Revision Date	October, 2004		Addition To Manual
1		277955001	MOTOR-MS18-2-117-A18-2A10-5000	1	Breakdown Fig 12-36
2		4235001	FITTING - PLUG - 10MORB - HEX	1	
3		72894001	O RING-SQ. #12 FLANGE	4	
4		296261719	MANIFOLD - MS 18 MOTOR	1	
5		72895001	O RING-SQ. #16 FLANGE	2	
6		67745001	FITTING - FLGH - 16CD62	4	
7		510335709	WASHER-LOCK-.44-.46X.78-.11-YZ	8	
8		250507001	BOLT 7/16-14 X 1 3/4"GR8 HEX Y	8	
9		235718001	BOLT-1/2-13X2 GR8 HEX ZINC PLT	8	
10		485025	WASHER-1/2 FLAT-HARDENED-YZ	8	
11		75493001	FITTING - TEST - 4MORB - 16MTP	2	
12		78060001	FLANGE- 20 CODE 62	4	
13		72896001	O RING-SQ. #20 FLANGE	2	
14		296261740	FITTING-PLUG-20-FLGH	2	
15		67746001	FITTING - FLGH - 12CD62	4	
16		233497001	WASHER-10.7X21X2.5MM HARD FLT	8	
17		296261742	THREADED STUD - M10 X 1.5 X 125	8	
18		61656001	NUT-HEX M10-1.50 CL8 YZ D934	8	
19		296028001	HOSE-HYD 5/8X22 10 FSJ ST/45 3000PSI	1	
20		53827001	FITT.-#10M O-RING-#10M JIC ST.	1	
21		277852001	PINION - 16 MODUEL - 12T- 4" FACE	1	
22		288454001	CAP - MS18 MOTOR	1	
23		506046014	WASHER-FLAT,M14,YZ,D125A	2	
24		507094035	SCREW-HCS,M14-2.00X35,8.8,YZ,ISO4017,FT	2	
25		296267783	HOSE-HYD-1X14.25 16CD629OS/ 16CD629OS	2	
26		296258405	HOSE - 1.00 X 24 12C62 90/90 G6K	1	
27		296258406	HOSE - 1.00 X 13.50 12C62 90/90 G6K	1	
28		296258304	SCREW - HCS .875 - 9 X2,GR8,YZ	10	
29		288459001	WASHER - 7/8 FLAT HARD ZINC PLATED	10	

Hyd-Motor-Thrust/Pullback Drive Assy(RR) Fig 5-12x05

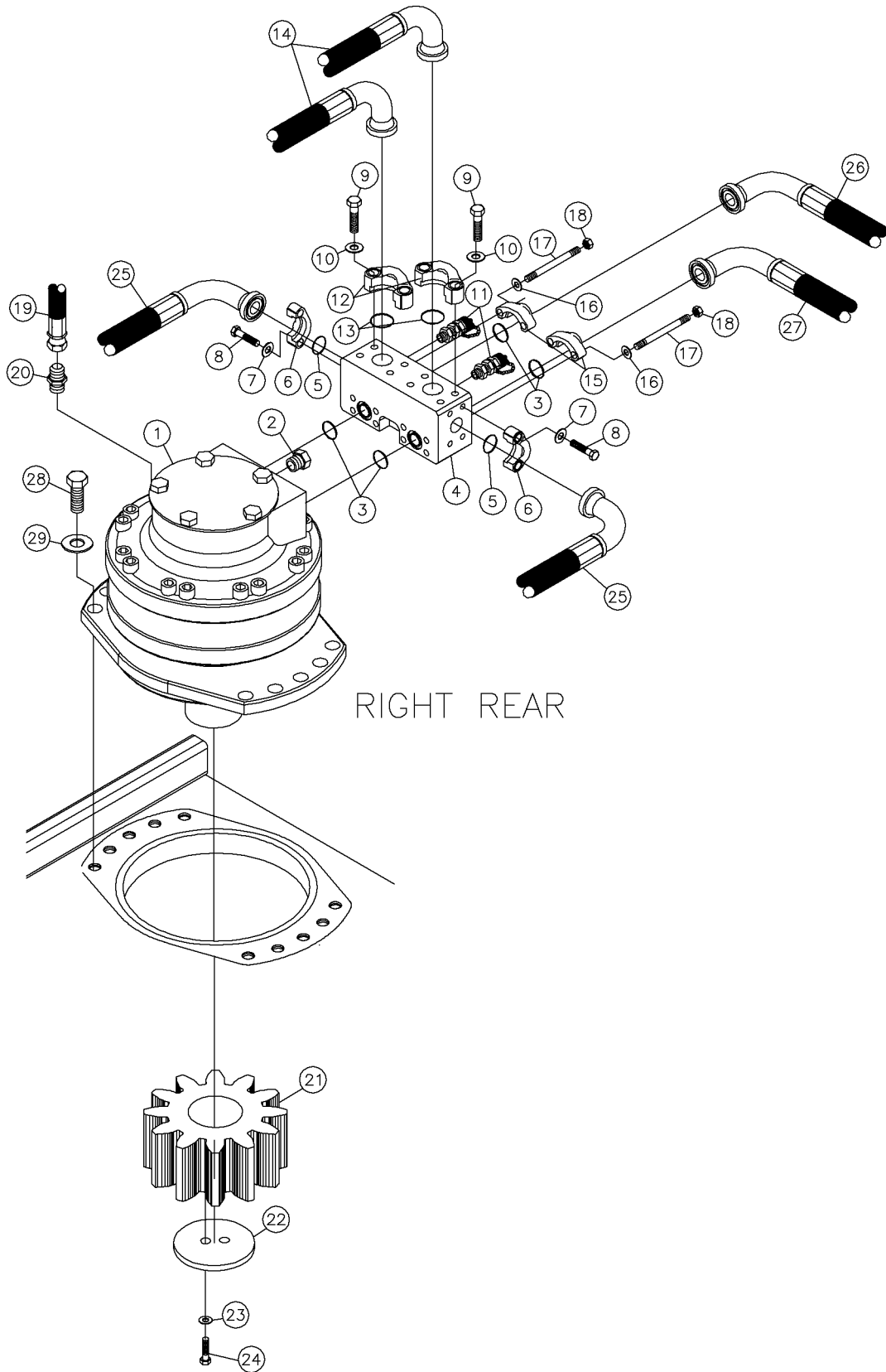

Hyd-Motor-Thrust/Pullback Drive Assy(RR) Fig 5-12x05

REF. NO.	*	PART NO.	DESCRIPTION	QTY.	REMARKS
		Revision Date	October, 2004		Addition To Manual
1		277955001	MOTOR-MS18-2-117-A18-2A10-5000	1	Breakdown Fig 12-36
2		4235001	FITTING - PLUG - 10MORB - HEX	1	
3		72894001	O RING-SQ. #12 FLANGE	4	
4		296261719	MANIFOLD - MS 18 MOTOR	1	
5		72895001	O RING-SQ. #16 FLANGE	2	
6		67745001	FITTING - FLGH - 16CD62	4	
7		510335709	WASHER-LOCK-.44-.46X.78-.11-YZ	8	
8		250507001	BOLT 7/16-14 X 1 3/4"GR8 HEX Y	8	
9		235718001	BOLT-1/2-13X2 GR8 HEX ZINC PLT	8	
10		485025	WASHER-1/2 FLAT-HARDENED-YZ	8	
11		75493001	FITTING - TEST - 4MORB - 16MTP	2	
12		78060001	FLANGE- 20 CODE 62	4	
13		72896001	O RING-SQ. #20 FLANGE	2	
14		296270796	HOSE-HYD-1.25X43-24C62/20C62-90-G6K	2	
15		67746001	FITTING - FLGH - 12CD62	4	
16		233497001	WASHER-10.7X21X2.5MM HARD FLT	8	
17		296261742	THREADED STUD - M10 X 1.5 X 125	8	
18		61656001	NUT-HEX M10-1.50 CL8 YZ D934	8	
19		296028001	HOSE-HYD 5/8X22 10 FSJ ST/45 3000PSI	1	
20		53827001	FITT.-#10M O-RING-#10M JIC ST.	1	
21		277852001	PINION - 16 MODUEL - 12T- 4" FACE	1	
22		288454001	CAP - MS18 MOTOR	1	
23		506046014	WASHER-FLAT,M14,YZ,D125A	2	
24		507094035	SCREW-HCS,M14-2.00X35,8.8,YZ,ISO4017,FT	2	
25		296267783	HOSE-HYD-1X14.25 16CD629OS/ 16CD629OS	2	
26		296258405	HOSE - 1.00 X 24 12C62 90/90 G6K	1	
27		296258406	HOSE - 1.00 X 13.50 12C62 90/90 G6K	1	
28		296258304	SCREW - HCS .875 - 9 X2,GR8,YZ	10	
29		288459001	WASHER - 7/8 FLAT HARD ZINC PLATED	10	

Hyd-Motor-Thrust/Pullback Drive Assy Fig 5-12

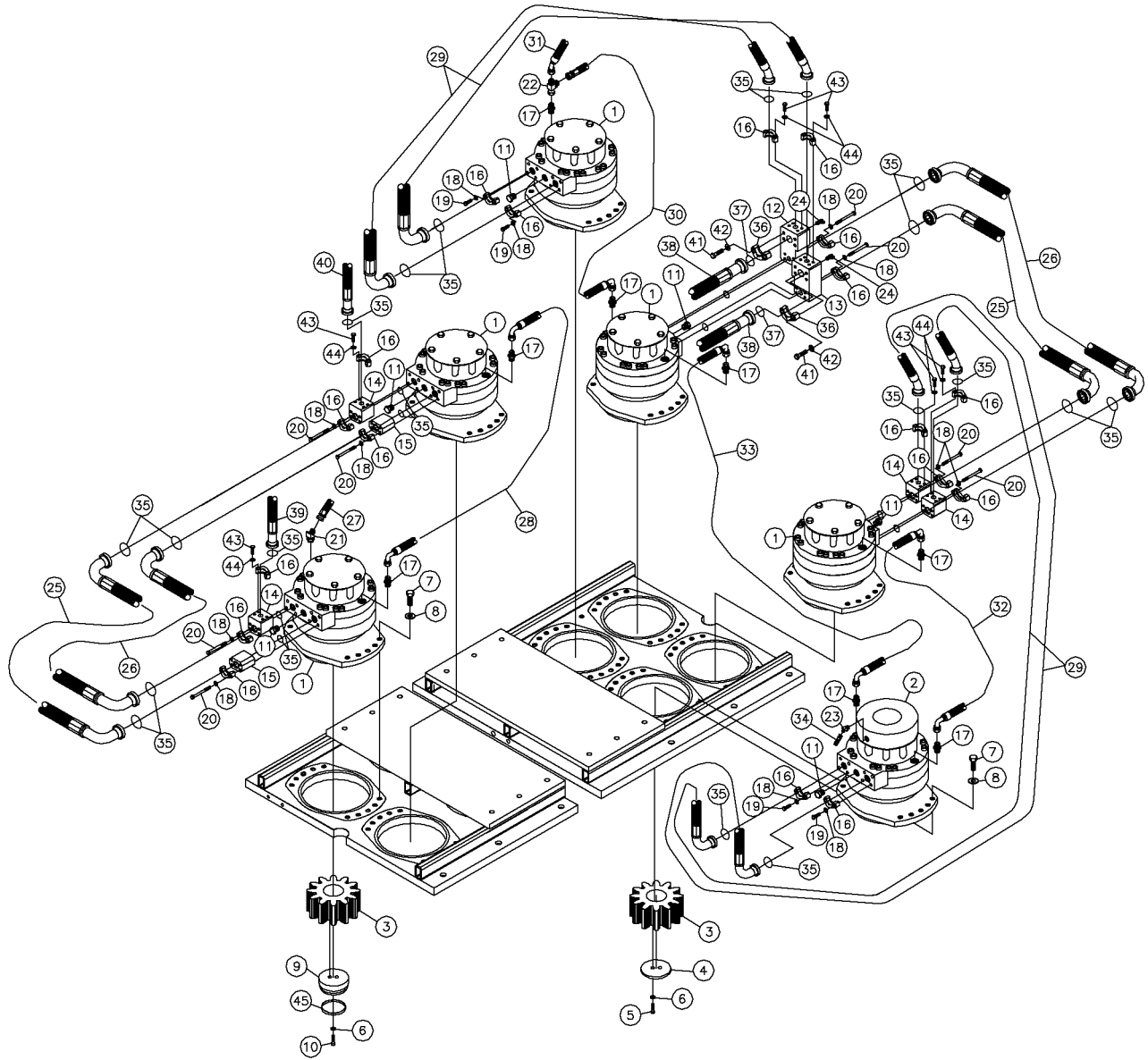

Hyd-Motor-Thrust/Pullback Drive Assy Fig 5-12

REF. NO.	*	PART NO.	DESCRIPTION	QTY.	REMARKS
1		277955001	MOTOR-MS18-2-117-A18-2A10-5000	5	Breakdown Fig12-36
2		277956001	MOTOR-MS18-2-117-F19-2A10-5000	1	Breakdown Fig12-35
3		277852001	PINION - 16 MODUEL - 12T- 4" FACE	6	
4		288454001	CAP - MS18 MOTOR	5	
5		507094035	SCREW-HCS,M14- 2.00X35,8.8,YZ,ISO4017,FT	10	
6		506046014	WASHER-FLAT,M14,YZ,D125A	12	
7		296258304	SCREW - HCS .875 - 9 X2,GR8,YZ	60	
8		288459001	WASHER - 7/8 FLAT HARD ZINC PLATED	60	
9		288498001	CAP - PPU MOUNT	1	
10		507094070	SCREW-HCS,M14- 2.00X70,8.8,YZ,ISO4014,PT	2	
11		4235001	10 M PLUG	6	
12		288461001	MANIFOLD - RIGHT	1	
13		288462001	MANIFOLD - LEFT	1	
14		288463001	MANIFOLD	4	
15		292922001	MANIFOLD - MOTOR	2	
16		67746001	SPLIT FLANGE HALF CODE 62/12	30	
17		53827001	FITT.-#10M O-RING-#10M JIC ST.	9	
18		233497001	WASHER-10.7X21X2.5MM HARD FLT	16	
19		249891001	BOLT-M10X35 10.9 HHCS D933 ZNC	16	
20		508476110	SCREW-HCS,M10- 1.50X110,10.9,YZ,ISO4014,PT	36	
21		56725001	FITTING-10MX10M JIC 45 DEG.	1	
22		100872001	FITTING-10FSJICX10MJIC RUN TEE	1	
23		82931001	FITTING-6MX4M JIC 45DEG.ELBOW	1	
24		75493001	COUPLER-MALE TCM20-7/16"UNF-V	2	
25		296258406	HOSE - 1.00 X 13.50 12C62 90/90 G6K	2	
26		296258405	HOSE - 1.00 X 24 12C62 90/90 G6K	2	
27		296258361	HOSE - .63 X 33 10FS JIC ST/ST M3K	1	
28		296258362	HOSE - .63 X 29 10FS JIC 90/90 M3K	1	
29		296258404	HOSE - .75 X 42 12C62 90/45 G6K	4	
30		296258364	HOSE - .63 X 13 10FS JIC ST/90 M3K	1	
31		296258363	HOSE - .63 X 30 10FS JIC ST/45 M3K	1	
32		296258365	HOSE - .63 X 14 10FS JIC 90/90 M3K	1	
33		296258366	HOSE - .63 X 16 10FS JIC 90/90 M3K	1	
34		53843481	HOSE-1/4X60 4FS JIC 3000 PSI	1	
35		72894001	O RING-SQ. #12 FLANGE	26	
36		78060001	FLANGE- 20 CODE 62	4	
37		72896001	O RING-SQ. #20 FLANGE	2	
38		296256882	HOSE - 1.25 X 42 24C62 /20C62 ST/22 G6K	2	
39		296256884	HOSE - .75 X 47 12C62 90/ST G6K	1	
40		296256883	HOSE - .75 X 42 12C62 90/ST G6K	1	
41		235718001	BOLT-1/2-13X2 GR8 HEX ZINC PLT	8	
42		485025	WASHER-1/2 FLAT-HARDENED-ZINC	8	
43		235723001	BOLT-3/8-16X1 1/2 GR8 ZINC PLT	24	
44		235713001	WASHER-3/8 SAE HARD ZINC PLTD	24	
45		234814001	RING-60 PULSE RING	1	

Hyd-Cylinder-Catwalk Assy Fig 5-13

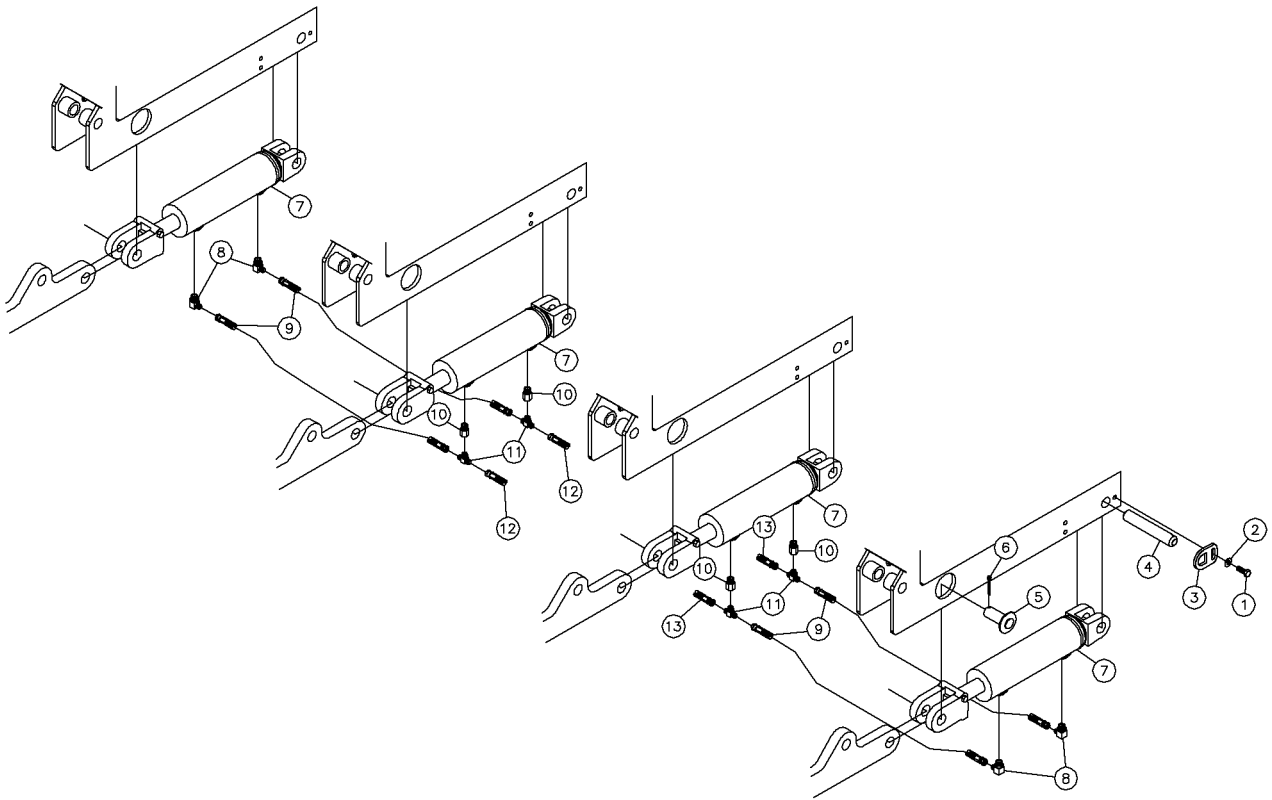

Hyd-Cylinder-Catwalk Assy Fig 5-13

REF. NO.	*	PART NO.	DESCRIPTION	QTY.	REMARKS
1		235727001	BOLT-3/8-16X1 GR8 HEX ZINC PLT	4	
2		235713001	WASHER-3/8 SAE HARD ZINC PLTD	4	
3		277961001	PLATE - PIN RETAINER	4	
4		277960001	PIN - 1" X 5.25"	4	
5		1795011	CYL. PIN - 1 X 2 3/4	4	
6		510338819	COTTER PIN-5/32" X 2"-YZ	4	
7		288468001	CYLINDER - 2.5" X 8" - 1 1/4" ROD	4	Breakdown Fig 12-17
8		57950001	FITTING-90-4MJ-6MORBA	4	
9		296258371	HOSE - .25 X 144 4FS JIC ST/ST M3K	4	
10		67291001	FITTING-6MX4F SOLID REDUCER	4	
11		81343001	FITTING-4M (BCH)X4M JICX4M JIC TEE	4	
12		296256889	HOSE - .25 X 37 4FS JIC ST/ST M3K	2	
13		296256892	HOSE - .25 X 115 4FS JIC ST/ST M3K	2	

Hyd-Cylinder-Rod Cradle Assy Fig 5-14

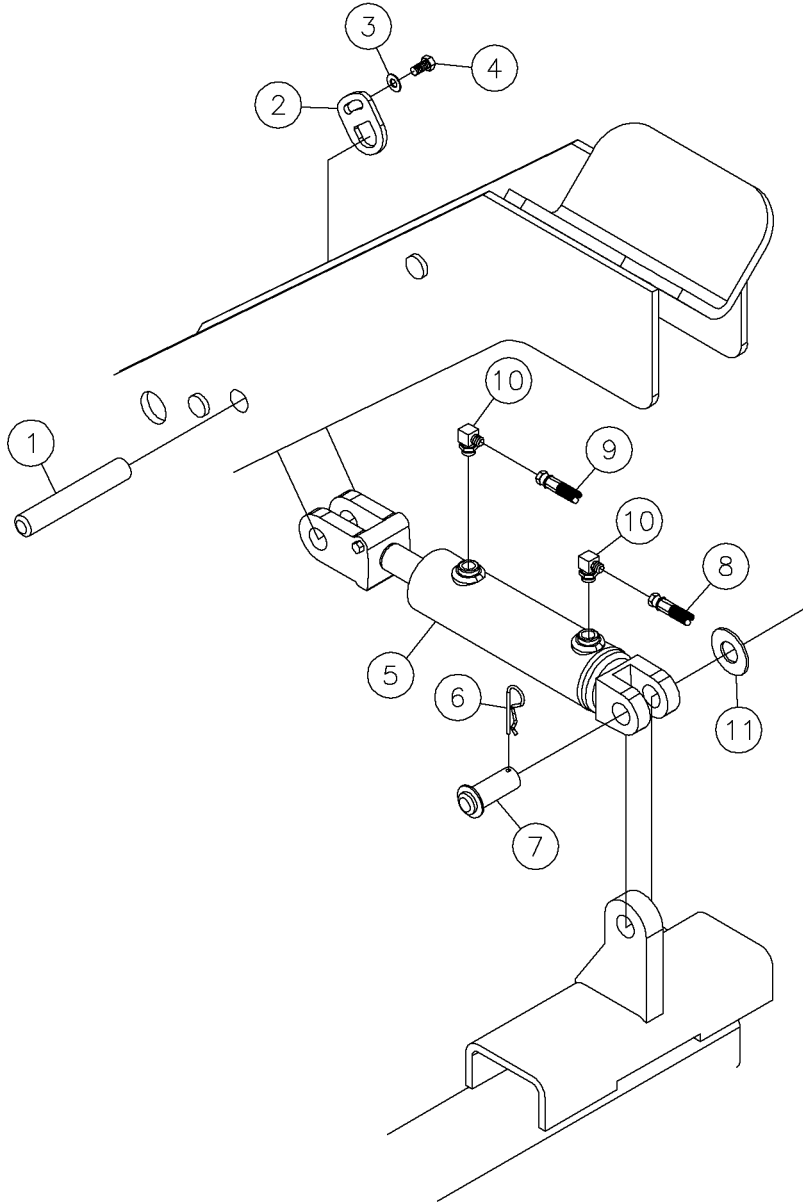

Hyd-Cylinder-Rod Cradle Assy Fig 5-14

REF. NO.	*	PART NO.	DESCRIPTION	QTY.	REMARKS
1		277976001	CYLINDER - ROD END PIN - 1 X 6	1	
2		277961001	PLATE - PIN RETAINER	1	
3		235713001	WASHER-3/8 SAE HARD ZINC PLTD	1	
4		235726001	BOLT-3/8-16X3/4 GR8 HEX ZNCPLT	1	
5		288468001	CYLINDER - 2.5" X 8" - 1 1/4" ROD	1	Breakdown Fig 12-17
6		20667001	HAIR PIN COTTER - .177 WIRE	1	
7		1795011	CYL. PIN - 1 X 2 3/4	1	
8		53843187	HOSE-1/4X44 4FS JIC 3000 PSI	1	
9		53843591	HOSE-1/4X52 4FS JIC 3000 PSI	1	
10		57950001	FITTING-90-4MJ-6MORBA	2	
11		238892001	WASHER-1" HARDENED FLAT ZY	1	

Hyd-Cylinder-Handrail Assy Fig 5-15

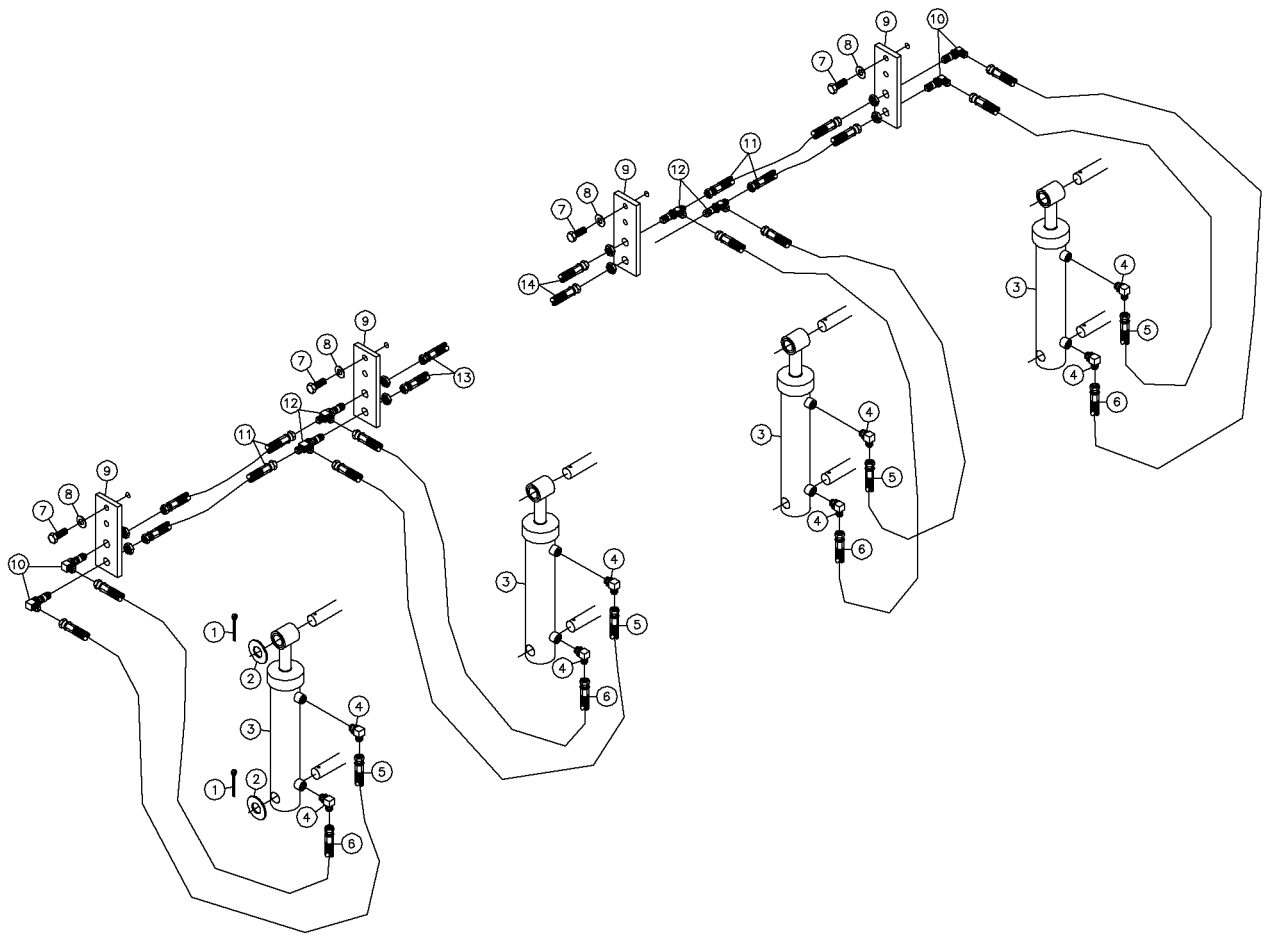

Hyd-Cylinder-Handrail Assy Fig 5-15

REF. NO.	*	PART NO.	DESCRIPTION	QTY.	REMARKS
1		510338819	COTTER PIN-5/32" X 2"-YZ	8	
2		235717001	WASHER-3/4 FLAT HARDENED YELLOW ZINC	8	
3		223998001	CYLINDER- 1 1/2 X 6	4	Breakdown Fig 12-16
4		59423001	FIT-4M JICX4M ADJ.90 DEG.ELBOW	8	
5		53843237	HOSE-1/4X80 4FS JIC 3000 PSI	4	
6		53843483	HOSE-1/4X72 4FS JIC 3000 PSI	4	
7		235727001	BOLT-3/8-16X1 GR8 HEX ZINC PLT	8	
8		235713001	WASHER-3/8 SAE HARD ZINC PLTD	8	
9		292928001	BLOCK BULKHEAD	4	
10		61497001	FITTING-4M JIC BULKHEAD 90DEG.	4	
11		296258371	HOSE - .25 X 144 4FS JIC ST/ST M3K	4	
12		88545001	FITTING-4M JIC BLKHD RUN TEE	4	
13		53843599	HOSE-1/4X40 4FS JIC 3000 PSI	2	
14		296256892	HOSE - .25 X 115 4FS JIC ST/ST M3K	2	

Hyd-Cylinder-Rack Lift Assy Fig 5-16r02

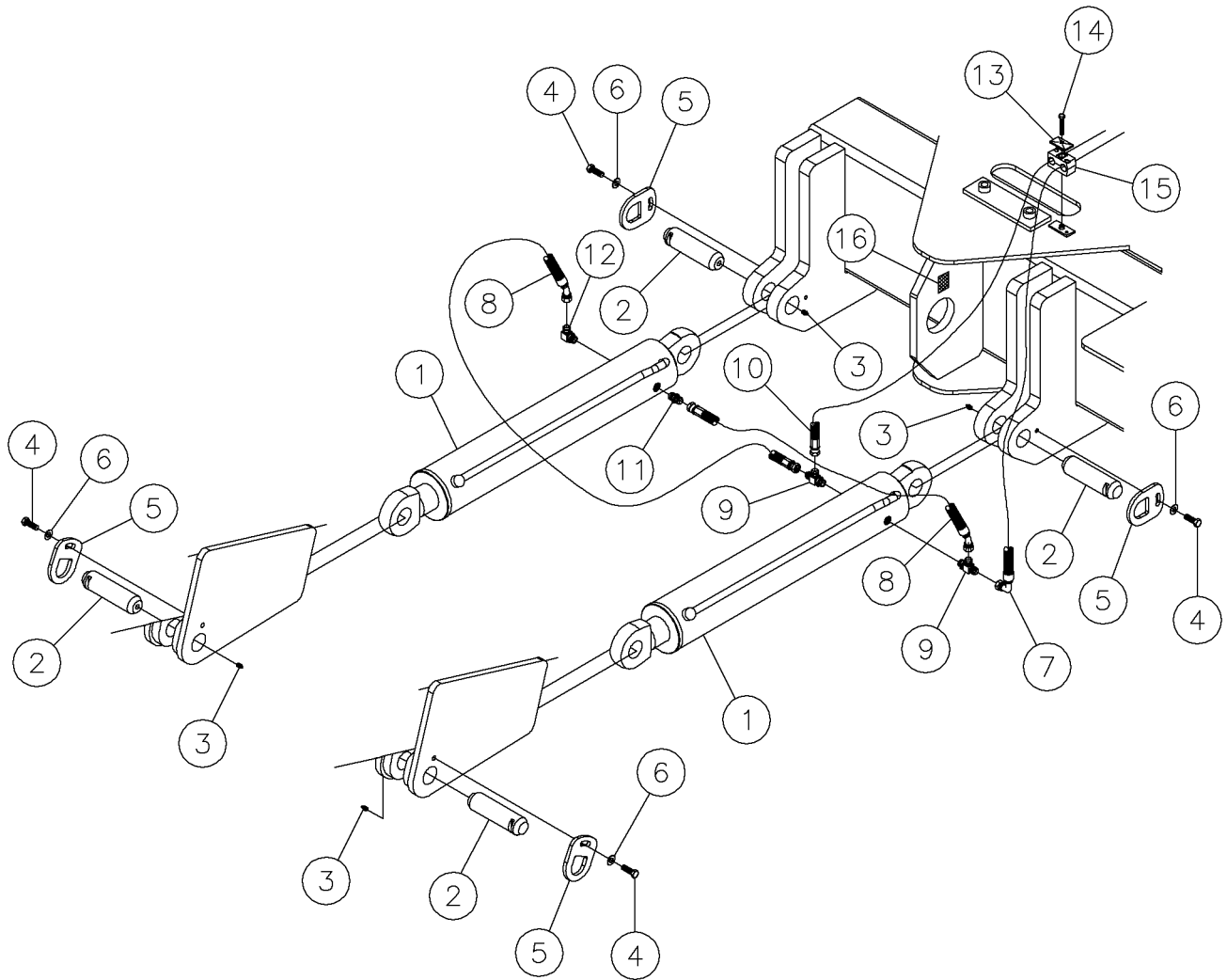

Hyd-Cylinder-Rack Lift Assy Fig 5-16r02

REF. NO.	*	PART NO.	DESCRIPTION	QTY.	REMARKS
		Revision Date	October, 2004		Update In Illustration & Parts List.
1		239373001	CYLINDER - 5" X 25"	2	Breakdown Fig. 12-18
2		277964001	PIN - 2" X 5.75" GREASE	4	
3		595001	ZERK-1/4" NPT ST GREASE REF T03042	4	
4		235737001	BOLT-1/2-13X1 1/4 GR8 ZINC PLT	4	
5		277965001	PLATE - PIN RETAINER - 2.0"	4	
6		485025	WASHER-1/2 FLAT-HARDENED-YZ	4	
7		296258374	HOSE - .50 X 144 8FS JIC ST/90 M3K	1	
8		296258375	HOSE - .50 X 42 8FS JIC ST/45 M3K	2	
9		81705001	FITTING-8MX8M JIC(RUN)X8M JIC	2	
10		296258369	HOSE - .50 X 144 8FS JIC ST/ST M3K	1	
11		53824001	FITTING-#8M O-RING-#8M JIC ST.	1	
12		53837001	FITTING - 8M O-RING X 8M JIC 90 DEGREE	1	
13		248030001	BOLT-5/16-18X1 3/4 GR8 ZINC PL	2	
14		72062005	PLATE-TOP CLAMP	2	
15		72062007	CLAMP - PAIR, 1/2 HYD HOSE	2	
16		70001834	DECAL - TIE DOWN POINT	2	

Hyd-Cylinder-Rack Lift Assy Fig 5-16r01

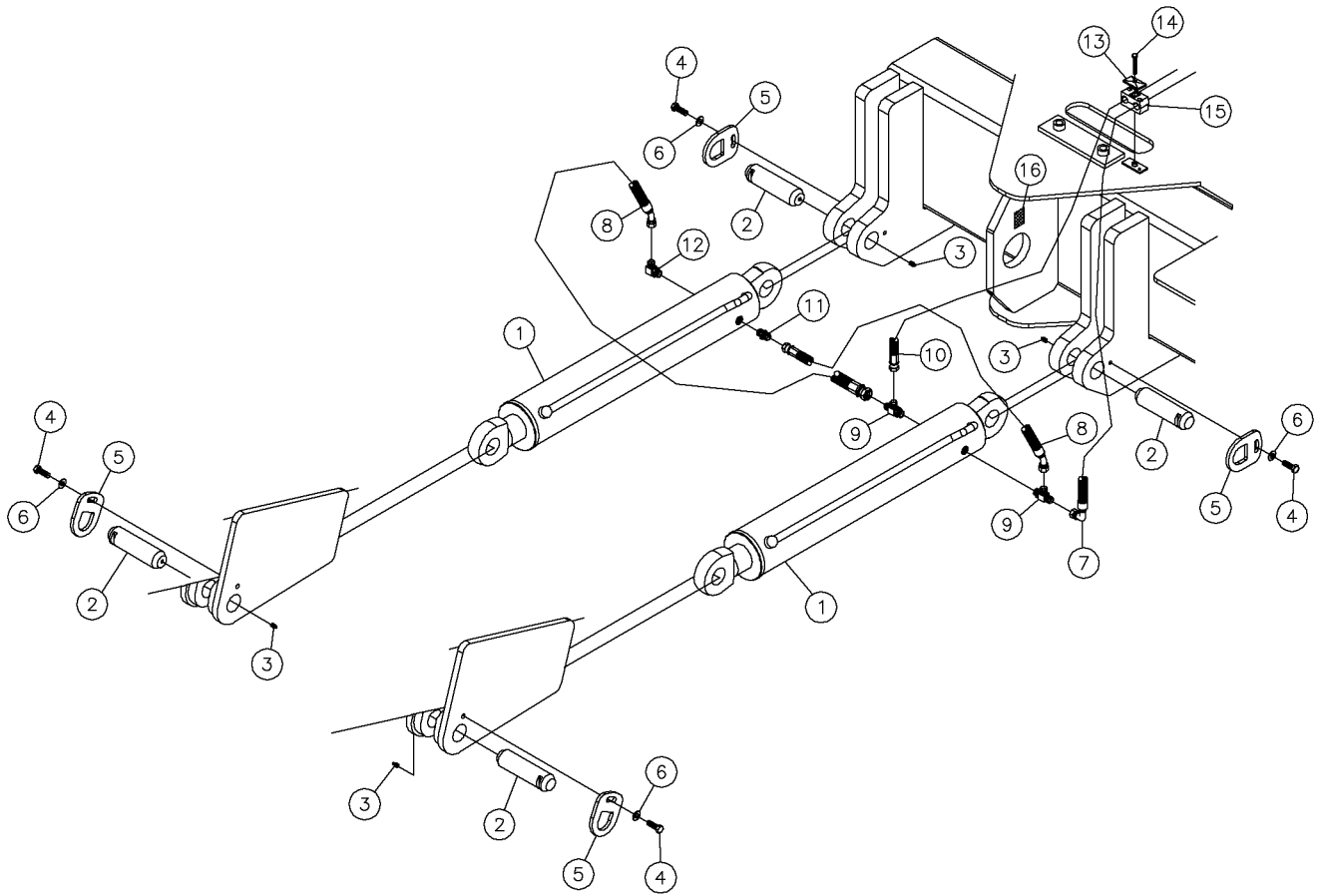

Hyd-Cylinder-Rack Lift Assy Fig 5-16r01

REF. NO.	*	PART NO.	DESCRIPTION	QTY.	REMARKS
		Revision Date	June, 2002		Update In Illustration & Parts List.
1		239373001	CYLINDER - 5" X 25"	2	Breakdown Fig 12-18
2	*	292675001	PIN - RACK LIFT GREASEABLE	4	
3		595001	ZERK-1/4" NPT ST GREASE	4	
4		235737001	BOLT-1/2-13X1 1/4 GR8 ZINC PLT	4	
5		277965001	PLATE - PIN RETAINER - 2.0"	4	
6		485025	WASHER-1/2 FLAT-HARDENED-ZINC	4	
7		296258374	HOSE - .50 X 144 8FS JIC ST/90 M3K	1	
8		296258375	HOSE - .50 X 42 8FS JIC ST/45 M3K	2	
9		81705001	FITTING-8MX8M JIC(BCH)X8M JIC	2	
10		296258369	HOSE - .50 X 144 8FS JIC ST/ST M3K	1	
11		53824001	FITTING-#8M O-RING-#8M JIC ST.	1	
12		53837001	FITTING - 8M O-RING X 8M JIC 90 DEGREE	1	
13		248030001	BOLT-5/16-18X1 3/4 GR8 ZINC PL	2	
14		72062005	PLATE-TOP CLAMP	2	
15		72062007	CLAMP - PAIR, 1/2 HYD HOSE	2	
16		70001834	DECAL - TIE DOWN POINT	2	

Hyd-Cylinder-Track Tension(Engine Side) Assy Fig 5-16x01

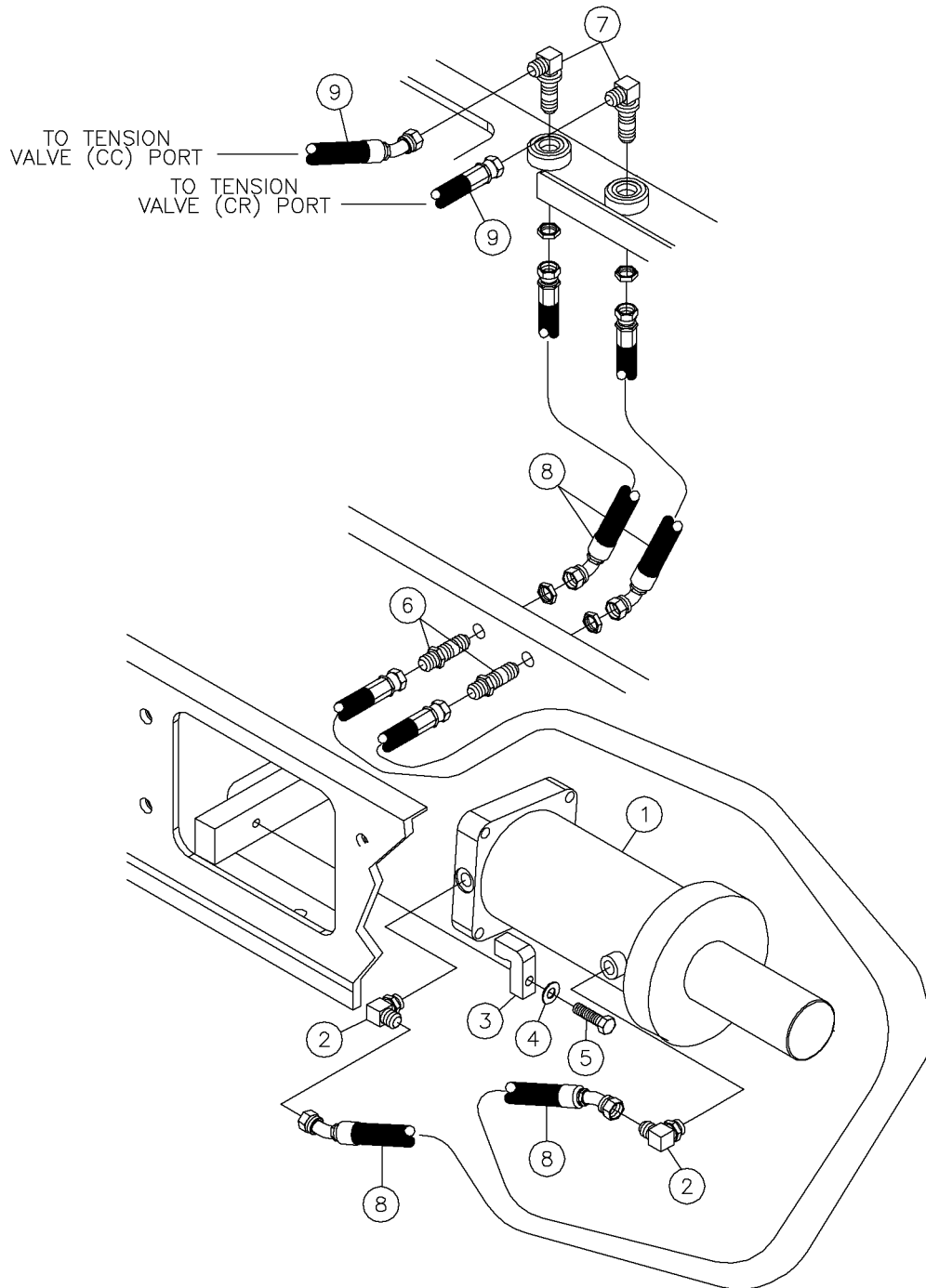

Hyd-Cylinder-Track Tension(Engine Side) Assy Fig 5-16x01

REF. NO.	*	PART NO.	DESCRIPTION	QTY.	REMARKS
		Revision Date	October, 2004		Addition To Manual
1		616370001	CYLINDER- 4.50 X 5.50 X 3.00	1	Breakdown Fig 12-51
2		53837001	FITTING - 8M O-RING X 8M JIC 90 DEGREE	2	
3		296275501	BLOCK-CYLINDER STOP	1	
4		485025	WASHER-1/2 FLAT-HARDENED-YZ	1	
5		243907001	SCREW-1/2 - 13X1 3/4 SHC ZP	1	
6		60927001	8 JIC BULKHEAD ST.UNION	2	
7		59407001	8M JICX10M ADJ. 90 DEG.ELBOW REF 59648-001-1	2	
8		296267986	HOSE - HYD - .50 X 15.5 8FSJ45/ST	4	
9		296267991	HOSE - HYD.50X27 8FSJST/ST 3000PSI	2	

Hyd-Cylinder-Track Tension(Rack Side) Assy Fig 5-16x02

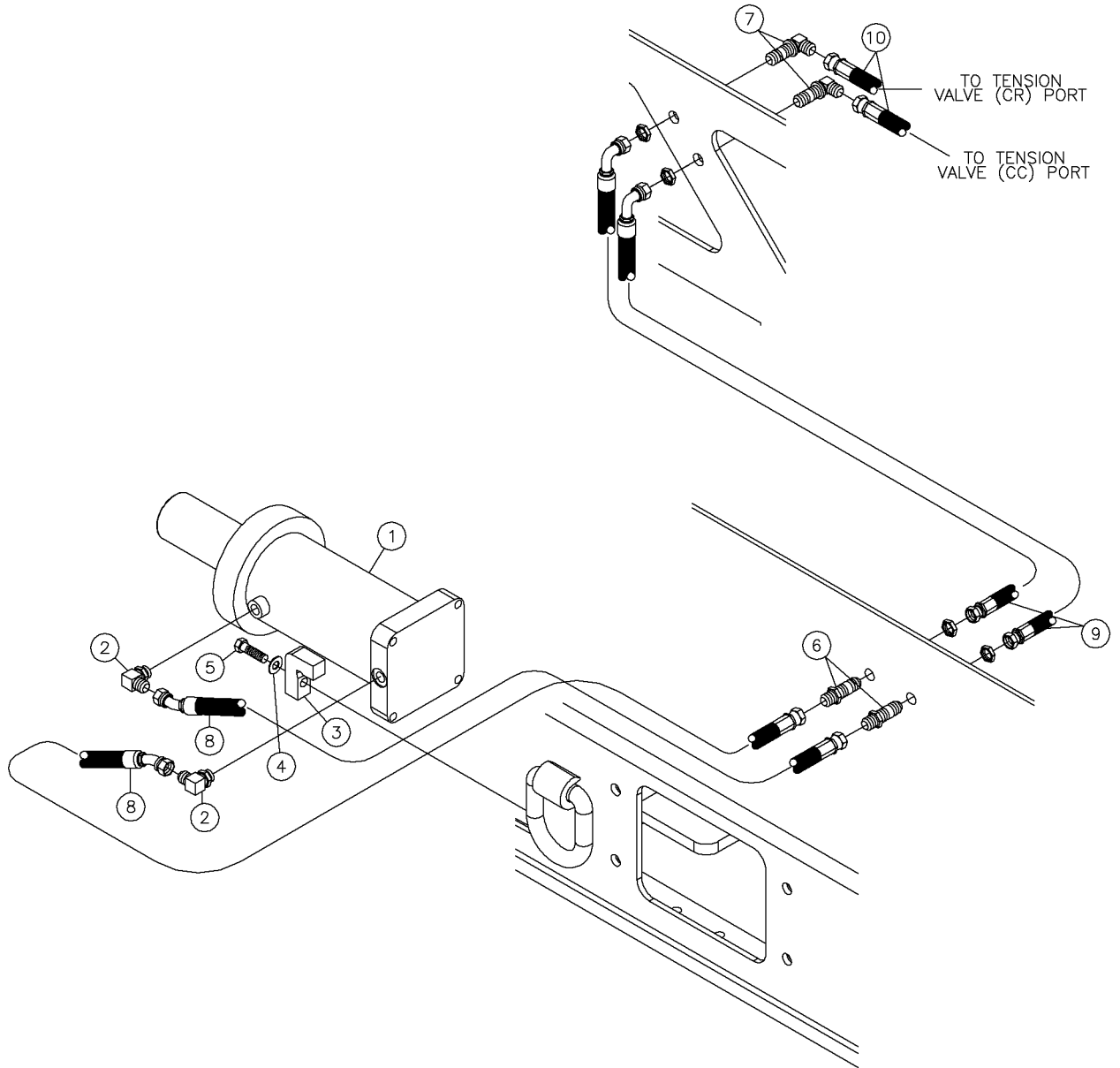

Hyd-Cylinder-Track Tension(Rack Side) Assy Fig 5-16x02

REF. NO.	*	PART NO.	DESCRIPTION	QTY.	REMARKS
		Revision Date	October, 2004		Addition To Manual
1		616370001	CYLINDER- 4.50 X 5.50 X 3.00	1	Breakdown Fig 12-51
2		53837001	FITTING - 8M O-RING X 8M JIC 90 DEGREE	2	
3		296275501	BLOCK-CYLINDER STOP	1	
4		485025	WASHER-1/2 FLAT-HARDENED-YZ	1	
5		243907001	SCREW-1/2 - 13X1 3/4 SHC ZP	1	
6		60927001	8 JIC BULKHEAD ST.UNION	2	
7		59407001	8M JICX10M ADJ. 90 DEG.ELBOW REF 59648-001-1	2	
8		296267986	HOSE - HYD - .50 X 15.5 8FSJ45/ST	2	
9		68208047	HOSE-1/2X52 8FSJIC/8FSJIC90	2	
10		53844197	HOSE-1/2X38 8FS JIC ST 3000	2	

Hyd-Cylinder-Rack Lift Assy Fig 5-16

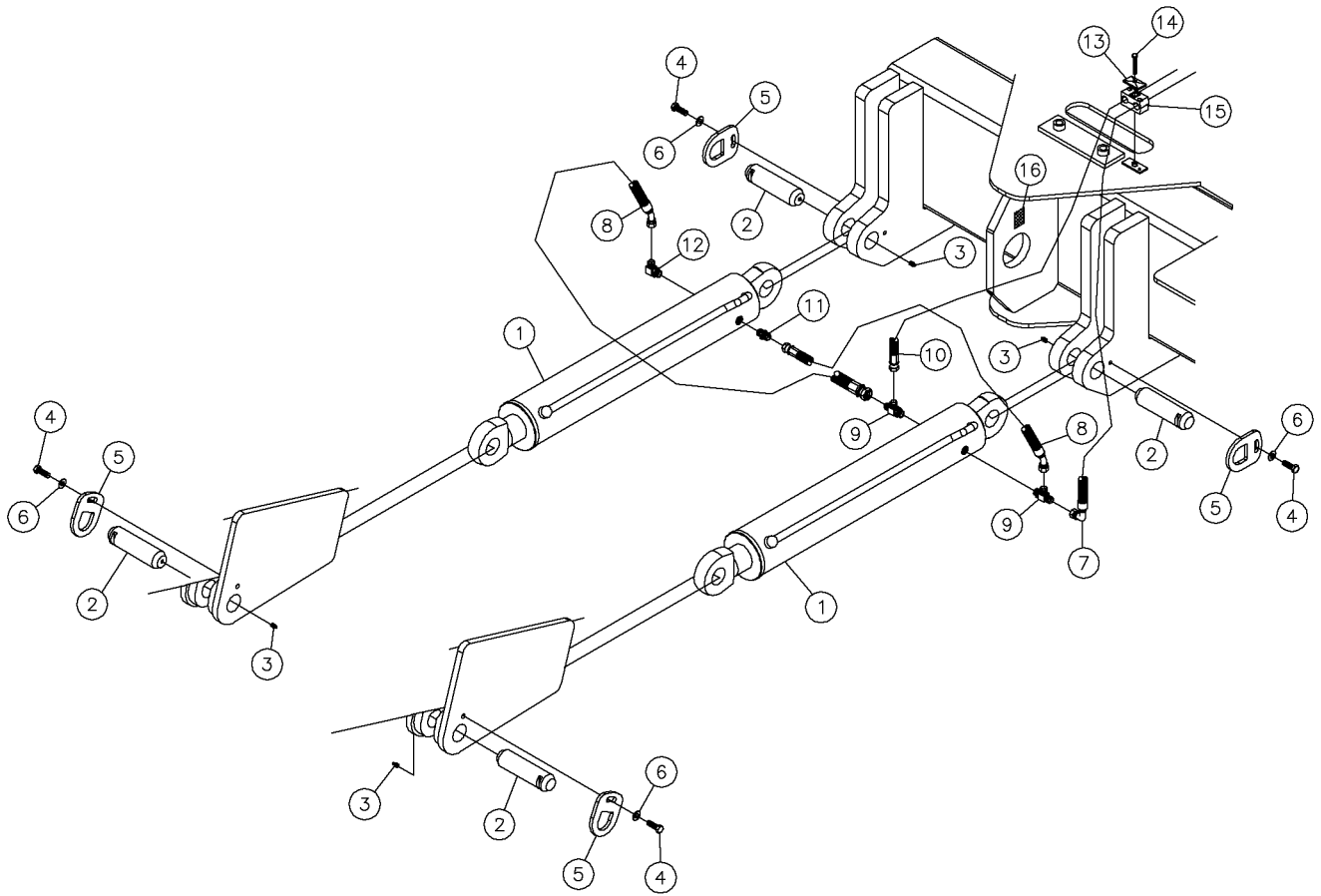

Hyd-Cylinder-Rack Lift Assy Fig 5-16

REF. NO.	*	PART NO.	DESCRIPTION	QTY.	REMARKS
1		239373001	CYLINDER - 5" X 25"	2	Breakdown Fig 12-18
2		277964001	PIN - 2" X 5.75" GREASE	4	
3		595001	ZERK-1/4" NPT ST GREASE	4	
4		235737001	BOLT-1/2-13X1 1/4 GR8 ZINC PLT	4	
5		277965001	PLATE - PIN RETAINER - 2.0"	4	
6		485025	WASHER-1/2 FLAT-HARDENED-ZINC	4	
7		296258374	HOSE - .50 X 144 8FS JIC ST/90 M3K	1	
8		296258375	HOSE - .50 X 42 8FS JIC ST/45 M3K	2	
9		81705001	FITTING-8MX8M JIC(BCH)X8M JIC	2	
10		296258369	HOSE - .50 X 144 8FS JIC ST/ST M3K	1	
11		53824001	FITTING-#8M O-RING-#8M JIC ST.	1	
12		53837001	FITTING - 8M O-RING X 8M JIC 90 DEGREE	1	
13		248030001	BOLT-5/16-18X1 3/4 GR8 ZINC PL	2	
14		72062005	PLATE-TOP CLAMP	2	
15		72062007	CLAMP - PAIR, 1/2 HYD HOSE	2	
16		70001834	DECAL - TIE DOWN POINT	2	

Hyd-Manifold-Pc Distribution Pump Assy Fig 5-17r02

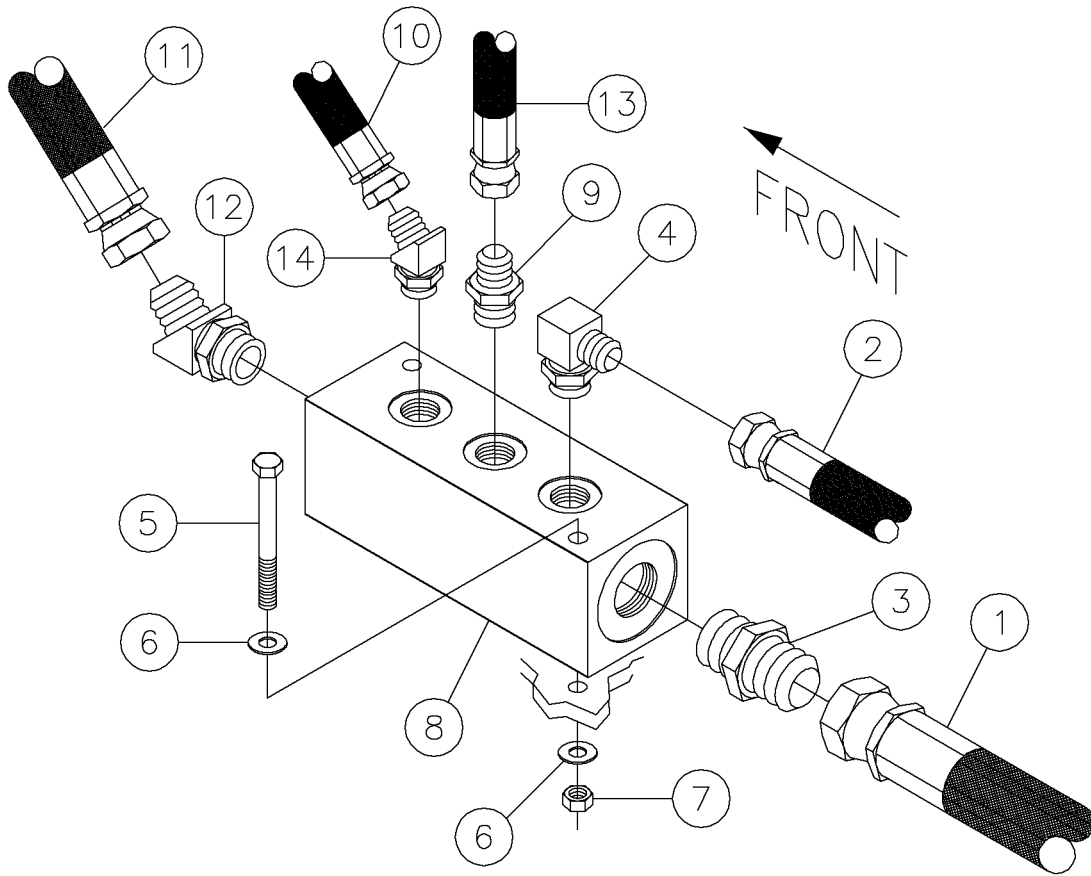

Hyd-Manifold-Pc Distribution Pump Assy Fig 5-17r02

REF. NO.	*	PART NO.	DESCRIPTION	QTY.	REMARKS
		Revision Date	October, 2004		Update In Illustration & Parts List.
1		296256875	HOSE - 1.00 X 101 16 FS JIC MEGA ST/45 G6K	1	
2		296256885	HOSE - .50 X 30 8FS JIC ST/90 M3K	1	
3		60907001	FITTING-16M JICX16M STR ADAPT	1	
4		59407001	8M JICX10M ADJ. 90 DEG.ELBOW	1	
5		250541001	BOLT-3/8-16 X 4" GR8 HEX Y/ZI	2	
6		235713001	WASHER - FLATSTRL - .38 - .41 X .81 - .06-YA-A325	4	
7		235725001	NUT - HEX - .38 - 16 - GR8 - YZ	2	
8		292899001	MANIFOLD - CASE DRAIN	1	
9		53826001	#10M O-RING-#8M JIC ST.	1	
10		296256886	HOSE - .50 X 57 8 FS JIC ST/ST M3K	1	
11		296050001	HOSE-HYD-.75X278 12FSJ ST/12 3000PSI M3K	1	
12		60718001	FITTING-45-12MJ-12MORBA	1	
13		244225001	HOSE-1/2X20 FSJIC ST/ST M3K	1	
14		59400001	8M JICX10M ADJ. 45 DEG.ELBOW	1	

Hyd-Manifold-Pc Distribution Pump Assy Fig 5-17r01

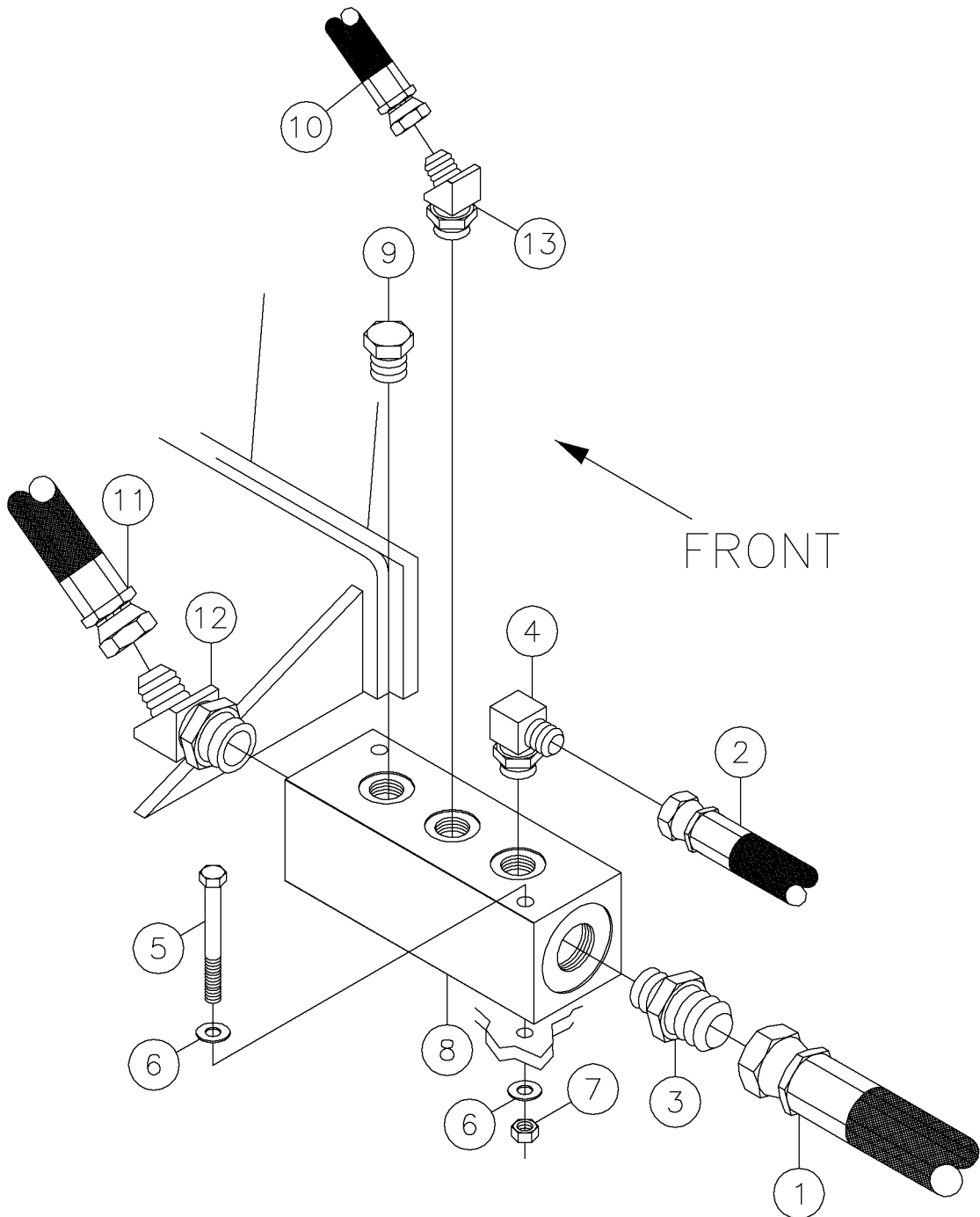

Hyd-Manifold-Pc Distribution Pump Assy Fig 5-17r01

REF. NO.	*	PART NO.	DESCRIPTION	QTY.	REMARKS
		Revision Date	June, 2002		Addition To Manual
1		296256875	HOSE - 1.00 X 101 16 FS JIC MEGA ST/45 G6K	1	
2		296256885	HOSE - .50 X 30 8FS JIC ST/90 M3K	1	
3	*	70009001	FITTING-12M X 16M JIC STR.	1	
4	*	59407001	FITTING-8M JICX10M ADJ. 90 DEG.ELBOW	1	
5		250541001	BOLT-3/8-16 X 4" GR8 HEX Y/ZI	2	
6		235713001	WASHER-3/8 SAE HARD ZINC PLTD	2	
7		235725001	NUT-3/8-16 GR8 ZINC PLTD	2	
8		292899001	MANIFOLD - CASE DRAIN	1	
9	*	4235001	FITTING - PLUG - 10MORB - HEX	1	
10		296256886	HOSE - .50 X 57 8 FS JIC ST/ST M3K	1	
11	*	296050001	HOSE-HYD-.75 X 278 12FSJ ST/ST 3000PSI	1	
12	*	81212001	FITTING-16MX12M JIC 45 ELBOW	1	
13	*	59400001	8M JICX10M ADJ. 45 DEG.ELBOW	1	

Hyd-Manifold-Pc Distribution Pump Assy Fig 5-17

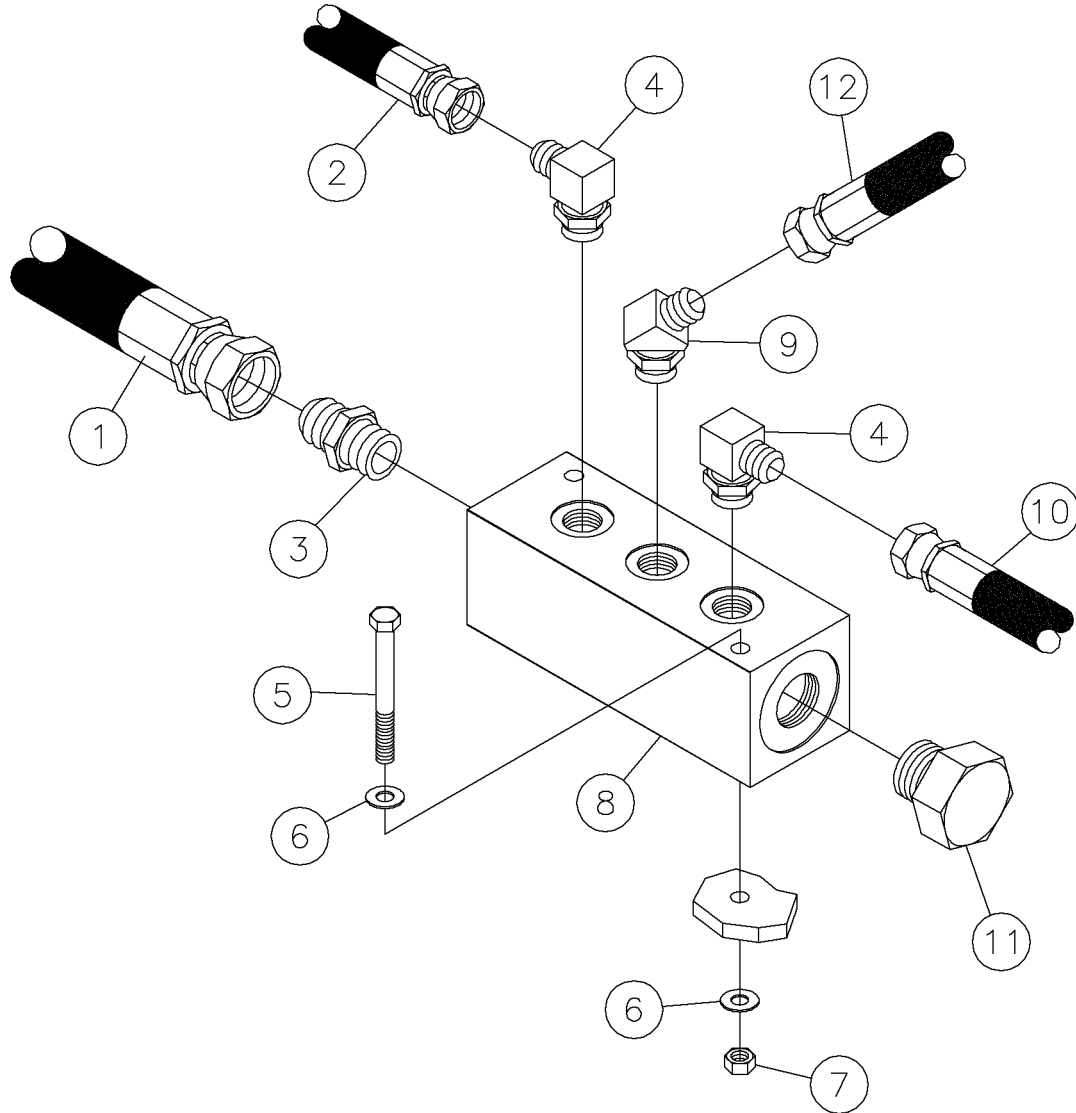

Hyd-Manifold-Pc Distribution Pump Assy Fig 5-17

REF. NO.	*	PART NO.	DESCRIPTION	QTY.	REMARKS
1		296256875	HOSE - 1.00 X 101 16 FS JIC MEGA ST/45 G6K	1	
2		296256885	HOSE - .50 X 30 8FS JIC ST/90 M3K	1	
3		53828001	#12M O-RING-#12M JIC ST.	1	
4		59407001	FITTING-8M JICX10M ADJ. 90 DEG.ELBOW	2	
5		250541001	BOLT-3/8-16 X 4" GR8 HEX Y/ZI	2	
6		235713001	WASHER-3/8 SAE HARD ZINC PLTD	2	
7		235725001	NUT-3/8-16 GR8 ZINC PLTD	2	
8		292899001	MANIFOLD - CASE DRAIN	1	
9		57948001	FITTING-10MX8JIC 45DEG	1	
10		296256886	HOSE - .50 X 57 8 FS JIC ST/ST M3K	1	
11		81214001	PLUG- 16M	1	
12		296258378	HOSE - .50 X 312 8FS JIC ST/ST M3K	1	

Hyd-Manifold-Case Drain Assy Fig 5-18r01

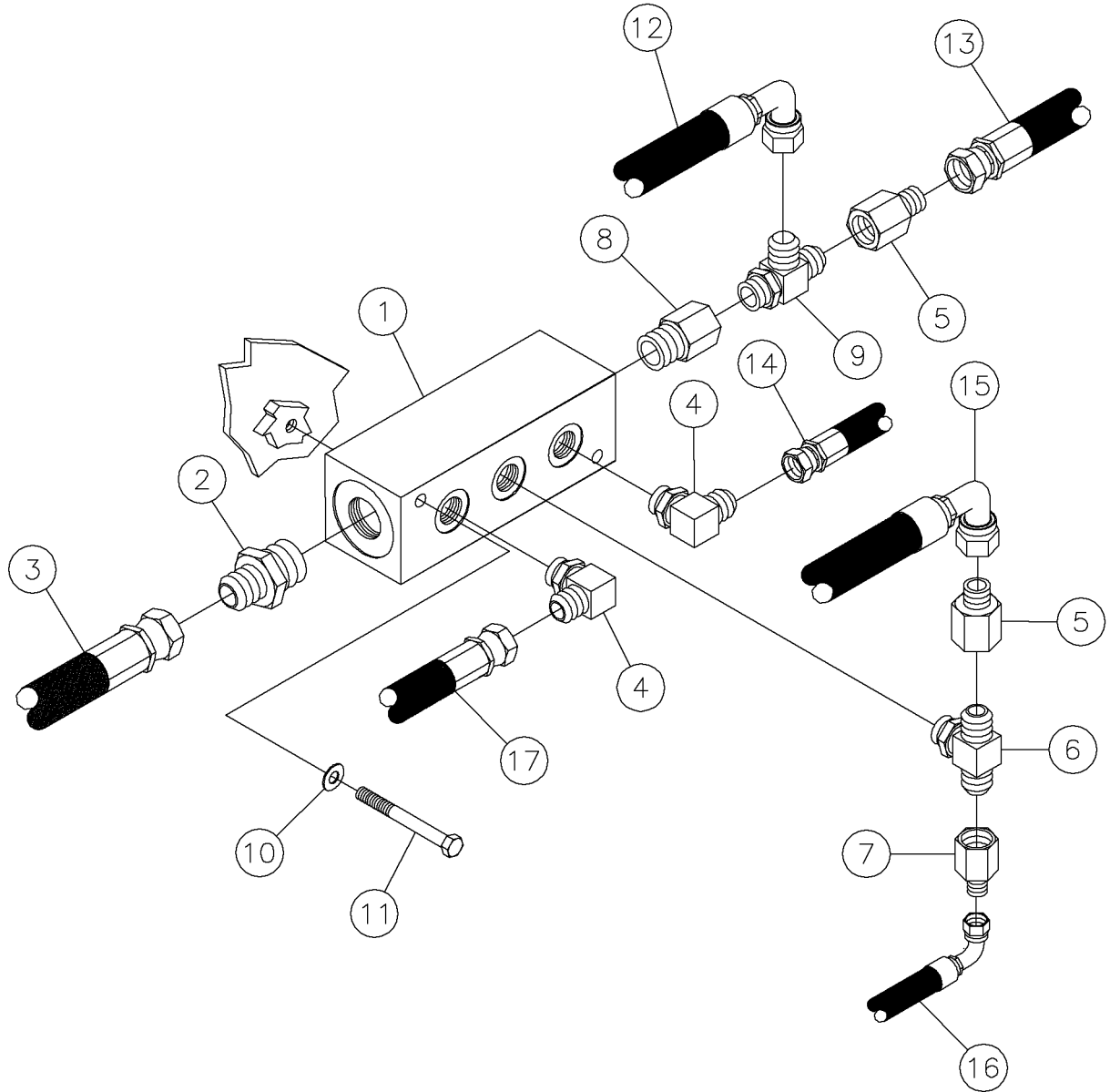

Hyd-Manifold-Case Drain Assy Fig 5-18r01

REF. NO.	*	PART NO.	DESCRIPTION	QTY.	REMARKS
		Revision Date	October, 2004		Update In Parts List.
1		292899001	MANIFOLD - CASE DRAIN	1	
2		71252001	FITTING - STR - 16MORB - 12FORB	1	
3		296270797	HOSE-HYD-1.00X526-16FSJ-ST/ST-M3K	1	
4		53829001	#10M O-RING-#10M JIC 90 DEG.	2	
5		86670001	FITTING-ADAPT 10FJICX8MJIC RED	1	
6		100873001	FITTING-10MX10MJIC RUN TEE	1	
7		71253001	FITTING-6M JICX10F JIC REDUCER	1	
8		682001	12 M X 10 F SOLID ADAPT.	1	
9		71250001	10M JIC(BCH)X10M JICX10FS JIC	1	
10		235713001	WASHER - FLATSTRL - .38 - .41 X .81 - .06-YA-A325	2	
11		16114034	BOLT-3/8-16X3 1/2 HEX HD. GR8	2	
12		256007001	HOSE-5/8 X 39 10FS JIC ST/90 3000 PSI	1	
13		53844249	HOSE-1/2X28 8FS JIC 3000 PSI	1	
14		296258361	HOSE - .63 X 33 10FS JIC ST/ST M3K	1	
15		296256880	HOSE - .50 X 42 8FS JIC ST/90 M3K	1	
16		296258359	HOSE - .38 X 27 6FS JIC ST/90 M3K	1	
17		296258363	HOSE - .63 X 30 10FS JIC ST/45 M3K	1	

Hyd-Manifold-Case Drain Assy Fig 5-18

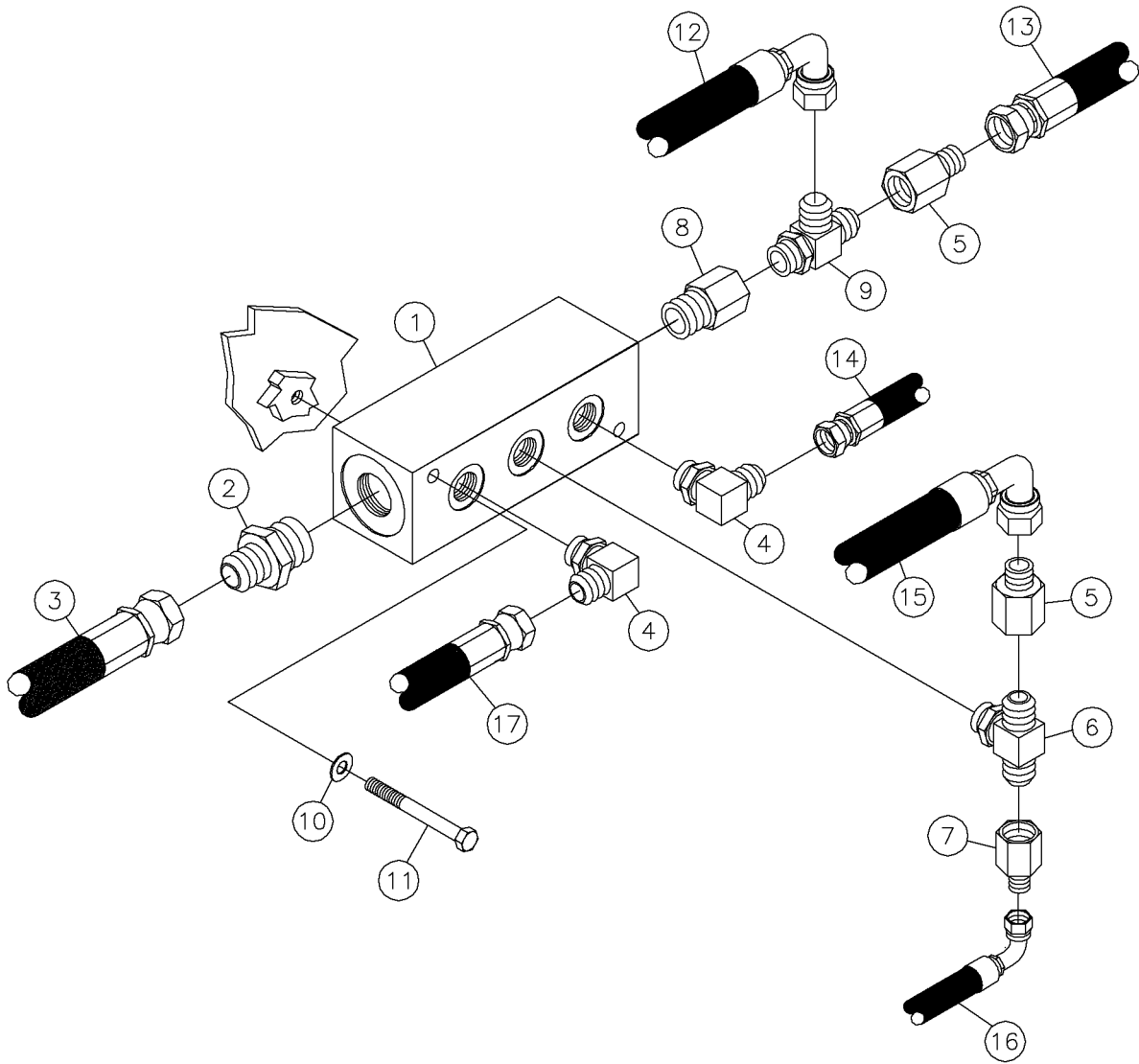

Hyd-Manifold-Case Drain Assy Fig 5-18

REF. NO.	*	PART NO.	DESCRIPTION	QTY.	REMARKS
1		292899001	MANIFOLD - CASE DRAIN	1	
2		71252001	FITTING-12FOR X 16MOR ADAPTER	1	
3		296256900	HOSE - .75 X 508 12 FS JIC ST/ST M3K	1	
4		53829001	#10M O-RING-#10M JIC 90 DEG.	2	
5		86670001	FITTING-ADAPT 10FJICX8MJIC RED	1	
6		100873001	FITTING-10MX10MJIC RUN TEE	1	
7		71253001	FITTING-6M JICX10F JIC REDUCER	1	
8		682001	12 M X 10 F SOLID ADAPT.	1	
9		71250001	FITTING-10M JIC(BCH)X10M JICX10FS JIC	1	
10		235713001	WASHER-3/8 SAE HARD ZINC PLTD	2	
11		16114034	BOLT-3/8-16X3 1/2 HEX HD. GR8	2	
12		256007001	HOSE-5/8 X 39 10FS JIC ST/90 3000 PSI	1	
13		53844249	HOSE-1/2X28 8FS JIC 3000 PSI	1	
14		296258361	HOSE - .63 X 33 10FS JIC ST/ST M3K	1	
15		296256880	HOSE - .50 X 42 8FS JIC ST/90 M3K	1	
16		296258359	HOSE - .38 X 27 6FS JIC ST/90 M3K	1	
17		296258363	HOSE - .63 X 30 10FS JIC ST/45 M3K	1	

Hyd-Manifold-Case Drain Assy Fig 5-19

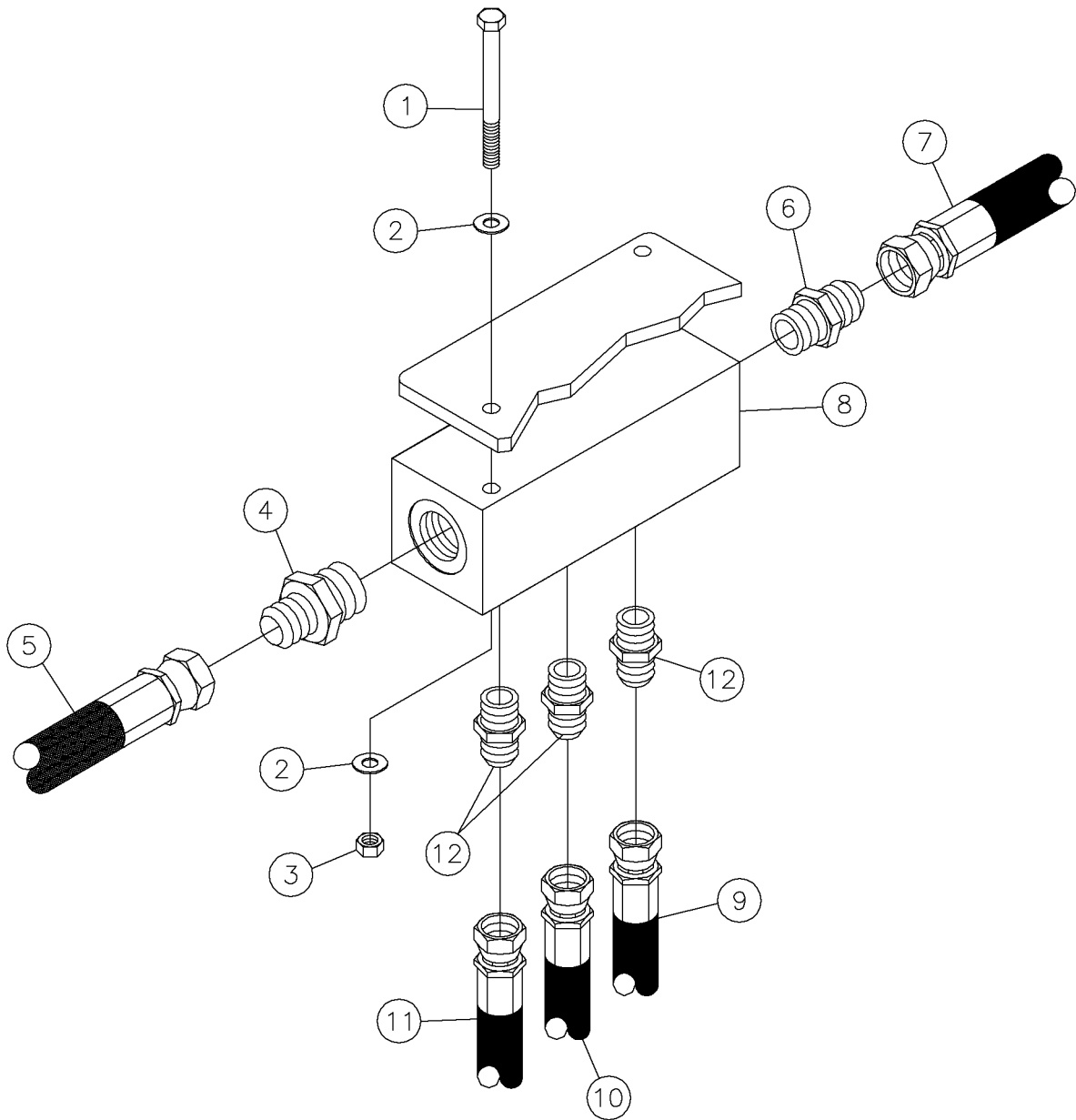

Hyd-Manifold-Case Drain Assy Fig 5-19

REF. NO.	*	PART NO.	DESCRIPTION	QTY.	REMARKS
1		250541001	BOLT-3/8-16 X 4" GR8 HEX Y/ZI	2	
2		235713001	WASHER-3/8 SAE HARD ZINC PLTD	4	
3		235725001	NUT-3/8-16 GR8 ZINC PLTD	2	
4		70008001	FITTING-16M X 12M JIC STR.	1	
5		296256878	HOSE - .75 X 91 12 FS JIC ST/ST M3K	1	
6		53828001	FITTING-#12M O-RING-#12M JIC ST.	1	
7		53845307	HOSE-3/4X70 12FS JIC 3000 PSI	1	
8		292899001	MANIFOLD - CASE DRAIN	1	
9		296256877	HOSE - .625 X 32 10 FS JIC ST/ST M3K	1	
10		296256879	HOSE - .625 X 57 10 FS JIC 90/ST M3K	1	
11		53842491	HOSE 5/8X45 10FSJICST/90D3000#	1	
12		53827001	FITT.-#10M O-RING-#10M JIC ST.	3	

Hyd-Manifold-Diagnostic Assy Fig 5-20r02

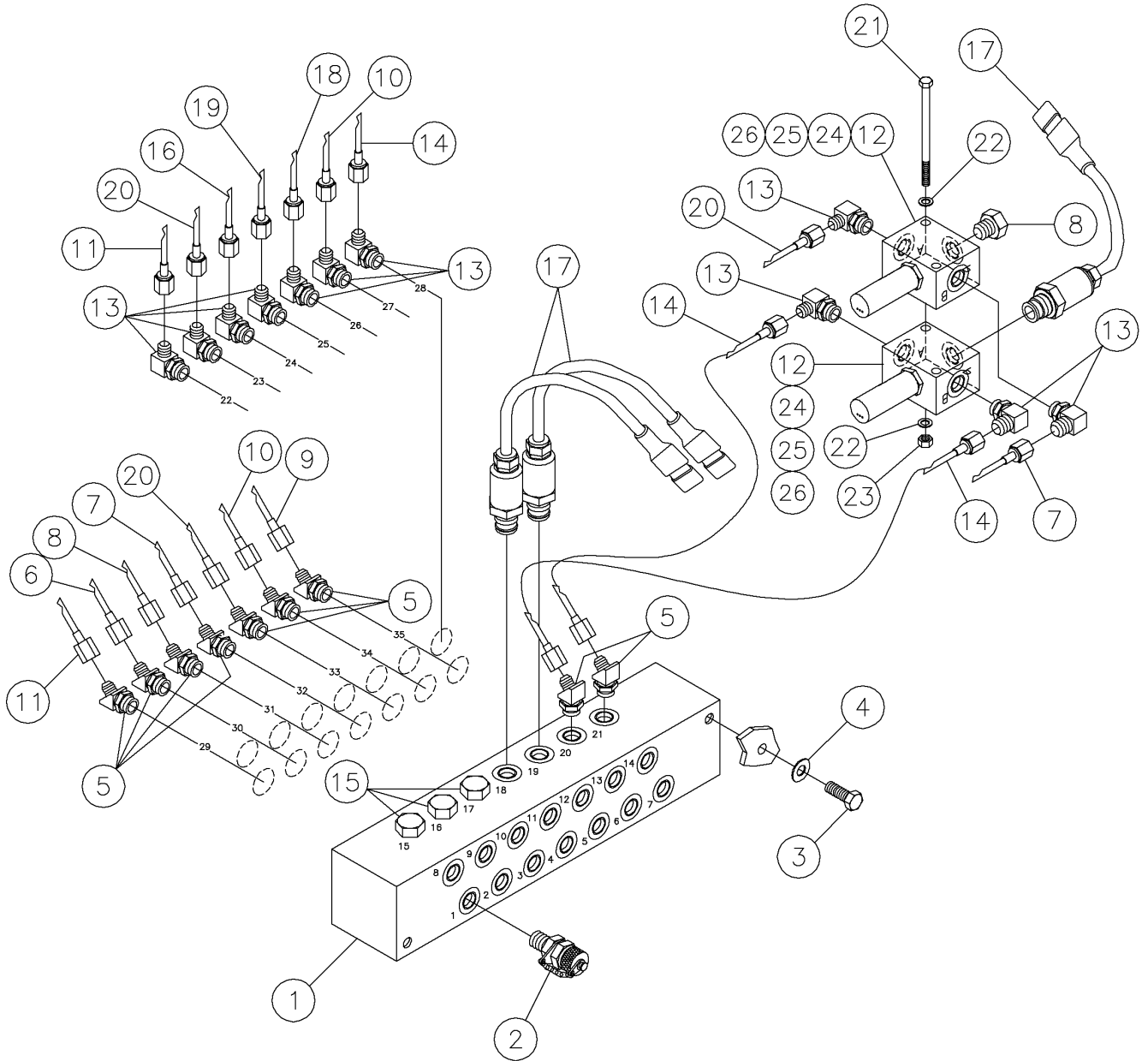

Hyd-Manifold-Diagnostic Assy Fig 5-20r02

REF. NO.	*	PART NO.	DESCRIPTION	QTY.	REMARKS
		Revision Date	November, 2004		Update In Illustration & Parts List.
1		296258279	MANIFOLD - DIAGNOSTIC	1	
2		72056001	FITTING-TEST-6MORB-16MTP	14	
3		235727001	BOLT-3/8-16X1 GR8 HEX ZINC PLT	2	
4		235713001	WASHER - FLATSTRL - .38 - .41 X .81 - .06-YA-A325	2	
5		82931001	FITTING-45-4MJX6MORBA	9	
6		296258425	HOSE - .08 X 34 4FS JIC ST/90 MICRO	1	
7		296258417	HOSE - .08 X 31 4FS JIC ST/ST MICRO	2	
8		296258423	HOSE - .08 X 24 4FS JIC ST/ST MICRO	1	
9		296258420	HOSE - .08 X 28 4FS JIC ST/ST MICRO	1	
10		296258419	HOSE - .08 X 21 4FS JIC ST/ST MICRO	2	
11		296256904	HOSE - .08 X 31 4FS/6FS JIC ST/ST MICRO	2	
12		296260319	VALVE - SHUTTLE W/PRESSURE SWITCH	1	
13		57950001	FITTING-90-4MJ-6MORBA	11	
14		296258418	HOSE - .08 X 14 4FS JIC ST/ST MICRO	3	
15		86678001	PLUG-6M ORING HOLLOW HEX	4	
16		296258422	HOSE - .08 X 26 4FS JIC ST/ST MICRO	1	
17		283059001	SENSOR - HYDRAULIC PRESSURE	3	
18		296258424	HOSE - .08 X 25 4FS JIC ST/90 MICRO	1	
19		296258421	HOSE - .08 X 18 4FS JIC ST/ST MICRO	1	
20		296258416	HOSE - .08 X 41 4FS JIC ST/ST MICRO	3	
21		238243001	SCREW - HCS- .25 - 20 X 4.00 - GR8 -YZ	2	
22		235716001	WASHER - FLATSTRL - .25 - .28 X .63 - .06 - CZ	4	
23		248198001	NUT-1/4 - 20 GR8 TOP LOCK ZINC	2	
24		296260320	SWITCH - 500 PSI PRESSURE	2	
25		296267116	SHUTTLE VALVE	2	
26		260040007	SEAL KIT	2	

Hyd-Manifold-Diagnostic Assy Fig 5-20r01

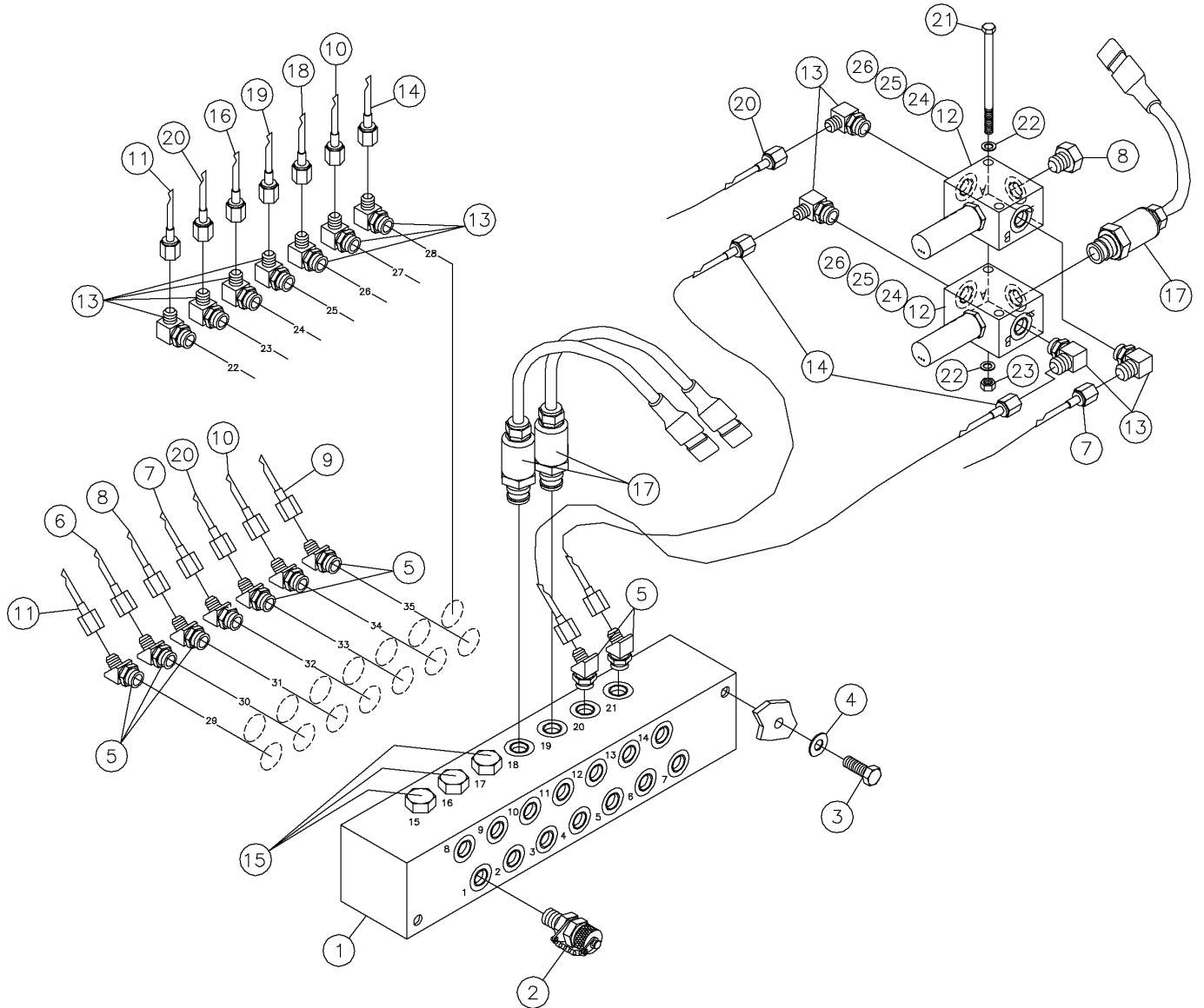

Hyd-Manifold-Diagnostic Assy Fig 5-20r01

REF. NO.	*	PART NO.	DESCRIPTION	QTY.	REMARKS
		Revision Date	June, 2002		Update In Illustration & Parts List.
1		296258279	MANIFOLD - DIAGNOSTIC	1	
2		72056001	FITTING-TEST-6MORB-16MTP	14	
3		235727001	BOLT-3/8-16X1 GR8 HEX ZINC PLT	2	
4		235713001	WASHER-3/8 SAE HARD ZINC PLTD	2	
5		82931001	FITTING-6MX4M JIC 45DEG.ELBOW	9	
6		296258425	HOSE - .08 X 34 4FS JIC ST/90 MICRO	1	
7		296258417	HOSE - .08 X 31 4FS JIC ST/ST MICRO	2	
8	*	296258423	HOSE - .08 X 24 4FS JIC ST/ST MICRO	1	
9		296258420	HOSE - .08 X 28 4FS JIC ST/ST MICRO	1	
10		296258419	HOSE - .08 X 21 4FS JIC ST/ST MICRO	2	
11		296256904	HOSE - .08 X 31 4FS/6FS JIC ST/ST MICRO	2	
12	*	296260319	VALVE - SHUTTLE W/PRESSURE SWITCH	1	
13		57950001	FITTING-90-4MJ-6MORBA	11	
14		296258418	HOSE - .08 X 14 4FS JIC ST/ST MICRO	3	
15		86678001	PLUG-6M ORING HOLLOW HEX	4	
16		296258422	HOSE - .08 X 26 4FS JIC ST/ST MICRO	1	
17	*	283059001	SENSOR-HYDRAULIC PRESSURE	3	
18		296258424	HOSE - .08 X 25 4FS JIC ST/90 MICRO	1	
19		296258421	HOSE - .08 X 18 4FS JIC ST/ST MICRO	1	
20		296258416	HOSE - .08 X 41 4FS JIC ST/ST MICRO	3	
21	*	238243001	BOLT 1/4"-20 X4 " GR 8 HEX YZ	2	
22	*	235716001	WASHER-1/4 SAE HARD ZINC PLTD	4	
23	*	248198001	NUT-1/4 - 20 GR8 TOP LOCK ZINC	2	
24	*	296260320	SWITCH - 500 PSI PRESSURE	2	
25	*	296267116	SHUTTLE VALVE	2	
26	*	296084007	SEAL KIT	2	

Hyd-Manifold-Diagnostic Assy Fig 5-20

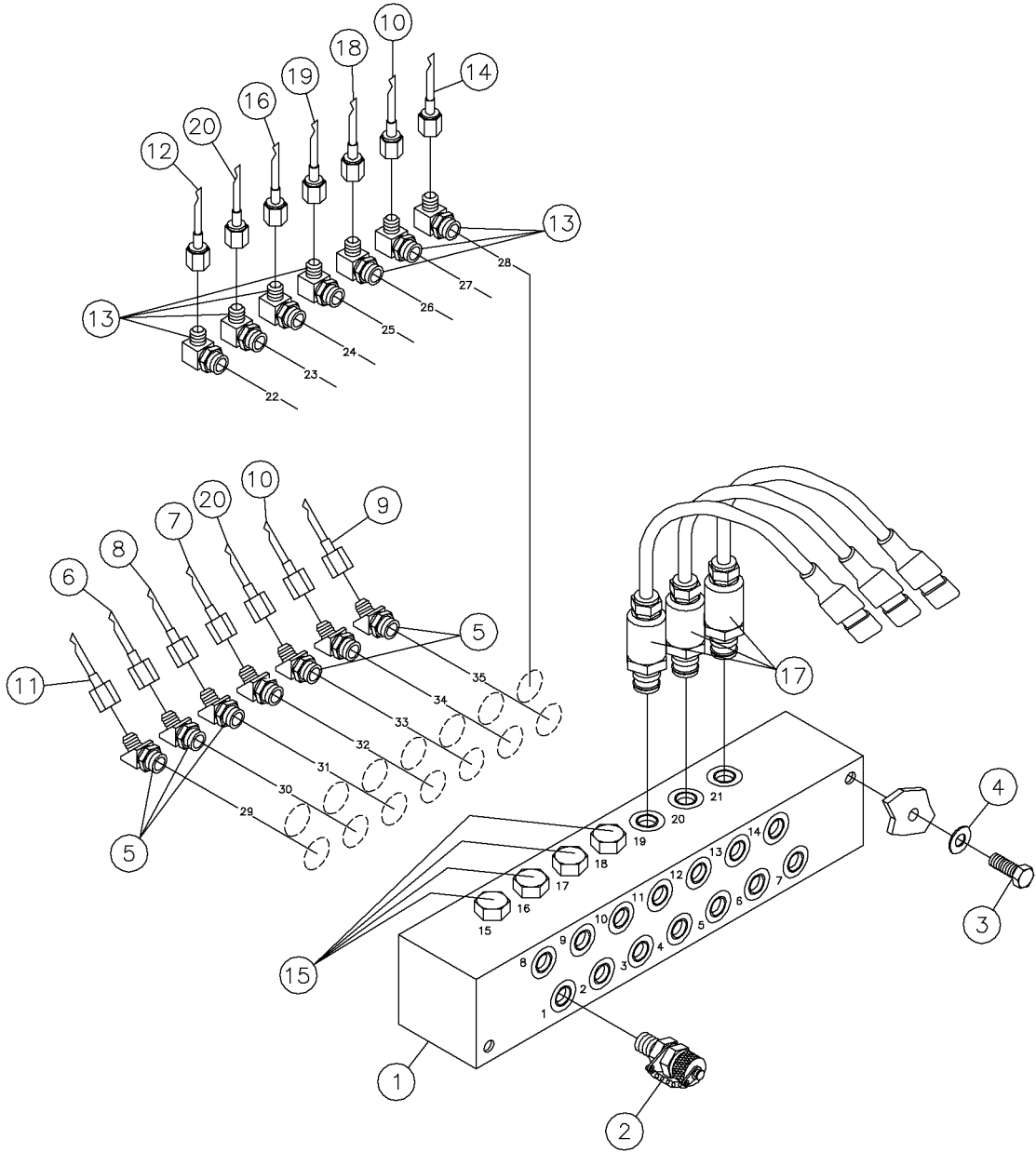

Hyd-Manifold-Diagnostic Assy Fig 5-20

REF. NO.	*	PART NO.	DESCRIPTION	QTY.	REMARKS
1		296258279	MANIFOLD - DIAGNOSTIC	1	
2		72056001	FITTING-TEST-6MORB-16MTP	14	
3		235727001	BOLT-3/8-16X1 GR8 HEX ZINC PLT	2	
4		235713001	WASHER-3/8 SAE HARD ZINC PLTD	2	
5		82931001	FITTING-6MX4M JIC 45DEG.ELBOW	7	
6		296258425	HOSE - .08 X 34 4FS JIC ST/90 MICRO	1	
7		296258417	HOSE - .08 X 31 4FS JIC ST/ST MICRO	1	
8		296258423	HOSE - .08 X 24 4FS JIC ST/ST MICRO	1	
9		296258420	HOSE - .08 X 28 4FS JIC ST/ST MICRO	1	
10		296258419	HOSE - .08 X 21 4FS JIC ST/ST MICRO	1	
11		296256904	HOSE - .08 X 31 4FS/6FS JIC ST/ST MICRO	1	
12		296256903	HOSE - .08 X 34 4FS JIC ST/ST MICRO	1	
13		57950001	FITTING-90-4MJ-6MORBA	7	
14		296258418	HOSE - .08 X 14 4FS JIC ST/ST MICRO	1	
15		86678001	PLUG-6M ORING HOLLOW HEX	4	
16		296258422	HOSE - .08 X 26 4FS JIC ST/ST MICRO	1	
17		283059001	SENSOR-HYRDAULIC PRESSURE	3	
18		296258424	HOSE - .08 X 25 4FS JIC ST/90 MICRO	1	
19		296258421	HOSE - .08 X 18 4FS JIC ST/ST MICRO	1	
20		296258416	HOSE - .08 X 41 4FS JIC ST/ST MICRO	2	

Hyd-Valve-High Speed Assy Fig 5-21

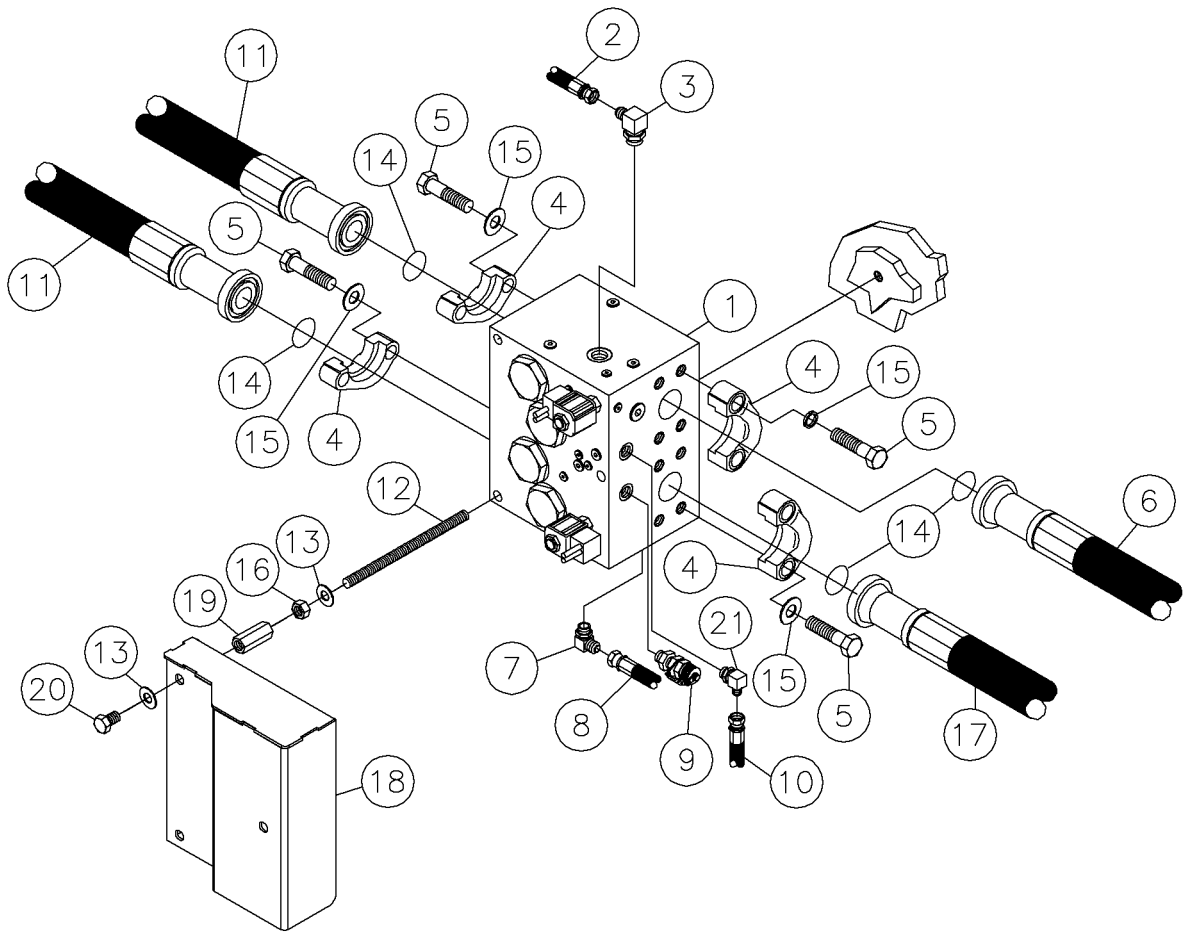

Hyd-Valve-High Speed Assy Fig 5-21

REF. NO.	*	PART NO.	DESCRIPTION	QTY.	REMARKS
1		277980001	VALVE - HIGH SPEED	1	Breakdown Fig 12-5
2		296256870	HOSE - .375 X 476 6FS JIC ST/ST M3K	1	
3		57954001	FITTING-8M X 6M JIC 90 DEGS	1	
4		72107001	FLANGE-1 1/2 CODE 62 H.D.	8	
5		238245001	BOLT 5/8" - 11 X 2 1/4 GR 8 HEX	16	
6		296258383	HOSE - 1.25 X 64 24C62/20C62 ST/ST G6K	1	
7		59426001	FITTING - 6M JIC X 6M O-RING ADJ 90 ELBOW	1	
8		296258359	HOSE - .38 X 27 6FS JIC ST/90 M3K	1	
9		72056001	FITTING-TEST-6MORB-16MTP	1	
10		53843481	HOSE-1/4X60 4FS JIC 3000 PSI	1	
11		296256882	HOSE - 1.25 X 42 24C62 /20C62 ST/22 G6K	2	
12		296258308	ROD - 1/2 X 8 TIE	3	
13		485025	WASHER-1/2 FLAT-HARDENED-ZINC	6	
14		72897001	O RING-SQ. #24 FLANGE	4	
15		235715001	WASHER-5/8 SAE HARD ZINC PLTD	16	
16		235731001	NUT-1/2-13 GR8 ZINC PLTD	3	
17		296258386	HOSE - 1.25 X 80 24C62/20C62 ST/22 G6K	1	
18		296258429	SHIELD - 2-SPD VALVE	1	
19		296261516	NUT COUPLING - .50-13X1.75-.75-CZ	3	
20		235728001	BOLT-1/2-13X3/4 GR8 ZINC PLTD	3	
21		57950001	FITTING-90-4MJ-6MORBA	1	

Hyd-Valve-Carriage Drive Motor Bleeder Fig 5-22r01

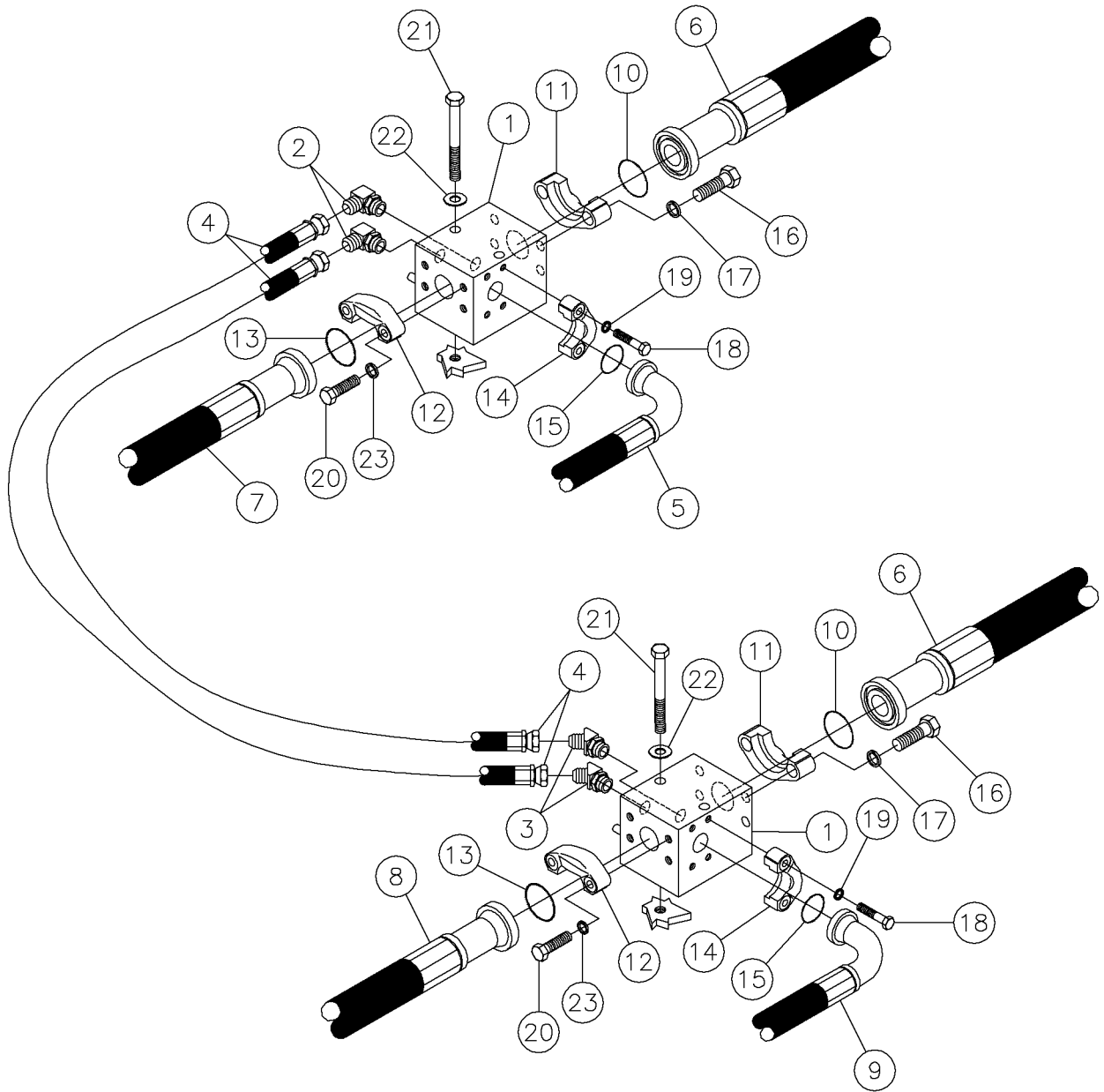

Hyd-Valve-Carriage Drive Motor Bleeder Fig 5-22r01

REF. NO.	*	PART NO.	DESCRIPTION	QTY.	REMARKS
		Revision Date	October, 2004		Update In Illustration & Parts List.
1		296261576	VALVE - T/P BLEEDER	2	
2		53837001	FITTING - 8M O-RING X 8M JIC 90 DEGREE	2	
3		53834001	#8M O-RING-#8M JIC 45 DEG.	2	
4		296261577	HOSE - HYD - .50 X 40 - 8FSJ - ST/ST-6000PSI-8G6K	2	
5		296256884	HOSE - HYD-1.00-47-16C62-90/ST-G6K	1	
6		296258398	HOSE - 1.50 X 445 24C62 90/ST G6K	2	
7		296258383	HOSE - 1.25 X 64 24C62/20C62 ST/ST G6K	1	
8		296258386	HOSE - 1.25 X 80 24C62/20C62 ST/22 G6K	1	
9		296256883	HOSE - HYD -1.00-42-16C62-90/ST-G6K	1	
10		72897001	O RING-SQ. #24 FLANGE	2	
11		606170001	FLANGE - CODE 61 #24 SPLIT EA	4	
12		78060001	FLANGE- 20 CODE 62	4	
13		72896001	O RING-SQ. #20 FLANGE	2	
14		67745001	FITTING - FLGH - 16CD62	4	
15		72895001	O RING-SQ. #16 FLANGE	2	
16		145645001	BOLT - 5/8 - 11 X 2 GR.8 PLATED	8	
17		510335715	WASHER-LOCK-.63-.65X1.08-.16-YZ	8	
18		250507001	BOLT 7/16-14 X 1 3/4"GR8 HEX Y	8	
19		510335709	WASHER-LOCK-.44-.46X.78-.11-YZ	8	
20		240334001	BOLT-1/2-13X1 3/4 GR8 ZINC PLT	8	
21		250568001	SCREW - HCS-.50-13 X 4.50-GR 8-YZ	4	
22		485025	WASHER-1/2 FLAT-HARDENED-YZ	4	
23		510335711	WASHER-LOCK-.50-.52X.87-.13-YZ	8	

Hyd-Valve-Carriage Drive Motor Bleeder Fig 5-22

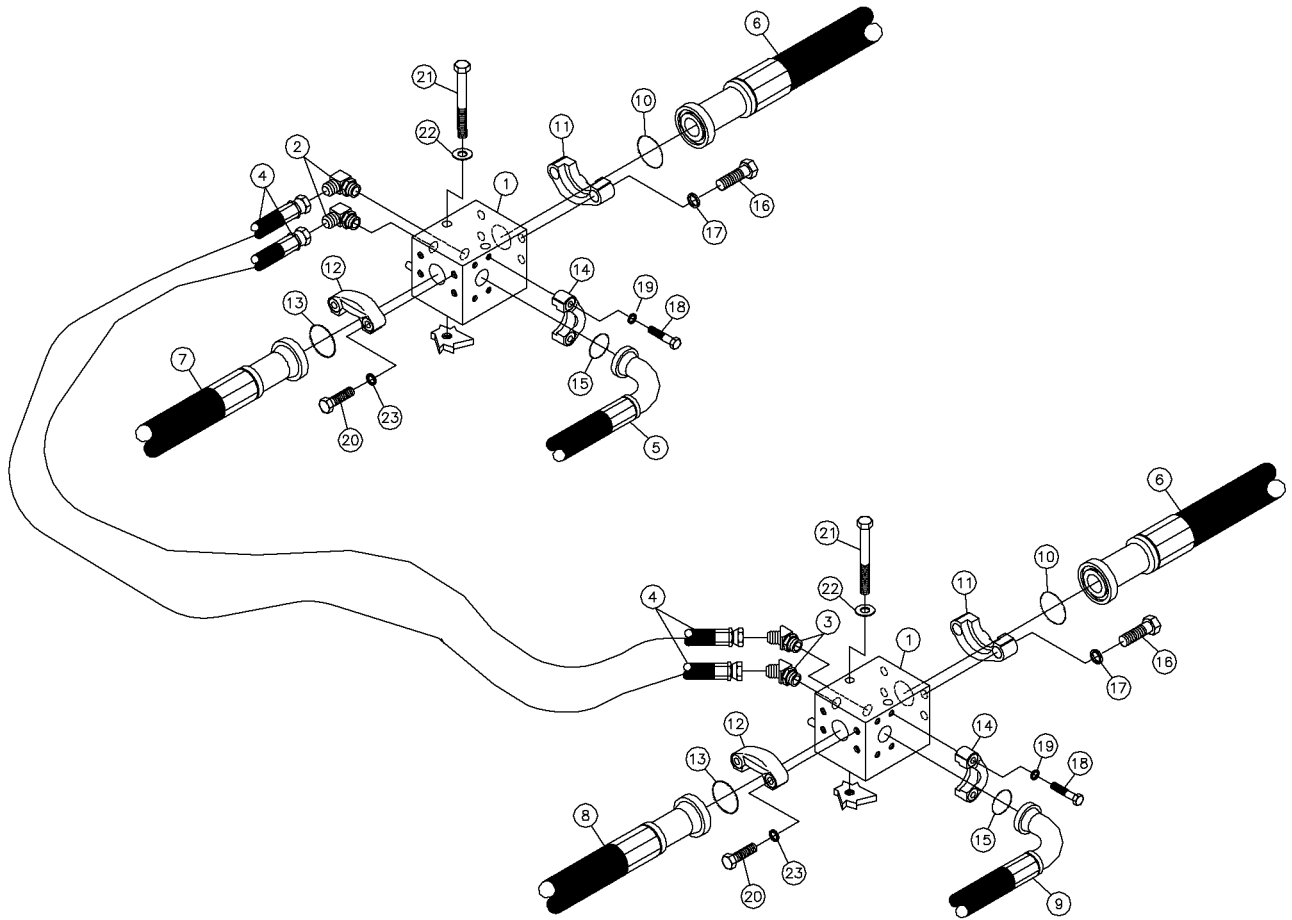

Hyd-Valve-Carriage Drive Motor Bleeder Fig 5-22

REF. NO.	*	PART NO.	DESCRIPTION	QTY.	REMARKS
1		296261576	VALVE - T/P BLEEDER	2	Breakdown Fig 12-9
2		53837001	FITTING - 8M O-RING X 8M JIC 90 DEGREE	2	
3		53834001	#8M O-RING-#8M JIC 45 DEG.	2	
4		296261577	HOSE - HYD - .50 X 40 - 8FSJ - ST/ST-6000PSI-8G6K	2	
5		296256884	HOSE - .75 X 47 12C62 90/ST G6K	1	
6		296258398	HOSE - 1.50 X 445 24C62 90/ST G6K	2	
7		296258383	HOSE - 1.25 X 64 24C62/20C62 ST/ST G6K	1	
8		296258386	HOSE - 1.25 X 80 24C62/20C62 ST/22 G6K	1	
9		296256883	HOSE - .75 X 42 12C62 90/ST G6K	1	
10		72897001	O RING-SQ. #24 FLANGE	2	
11		606170001	FLANGE - CODE 61 #24 SPLIT PR	4	
12		78060001	FLANGE- 20 CODE 62	4	
13		72896001	O RING-SQ. #20 FLANGE	2	
14		67745001	SPLIT FLANGE HALF CODE 62/16	4	
15		72895001	O RING-SQ. #16 FLANGE	2	
16		145645001	BOLT - 5/8 - 11 X 2 GR.8 PLATED	8	
17		510335715	WASHER-LOCK-.63-.65X1.08-.16-YZ	8	
18		250507001	BOLT 7/16-14 X 1 3/4"GR8 HEX Y	8	
19		510335709	WASHER-LOCK-.44-.46X.78-.11-YZ	8	
20		240334001	BOLT-1/2-13X1 3/4 GR8 ZINC PLT	8	
21		250568001	BOLT 1/2-13 X 4 1/2 GR8 HEX Y/Z	4	
22		485025	WASHER-1/2 FLAT-HARDENED-ZINC	4	
23		51033711	WASHER-LOCK-.50-.52X.87-.13-YZ	8	

Hyd-Valve-Diverter Assy Fig 5-23r01

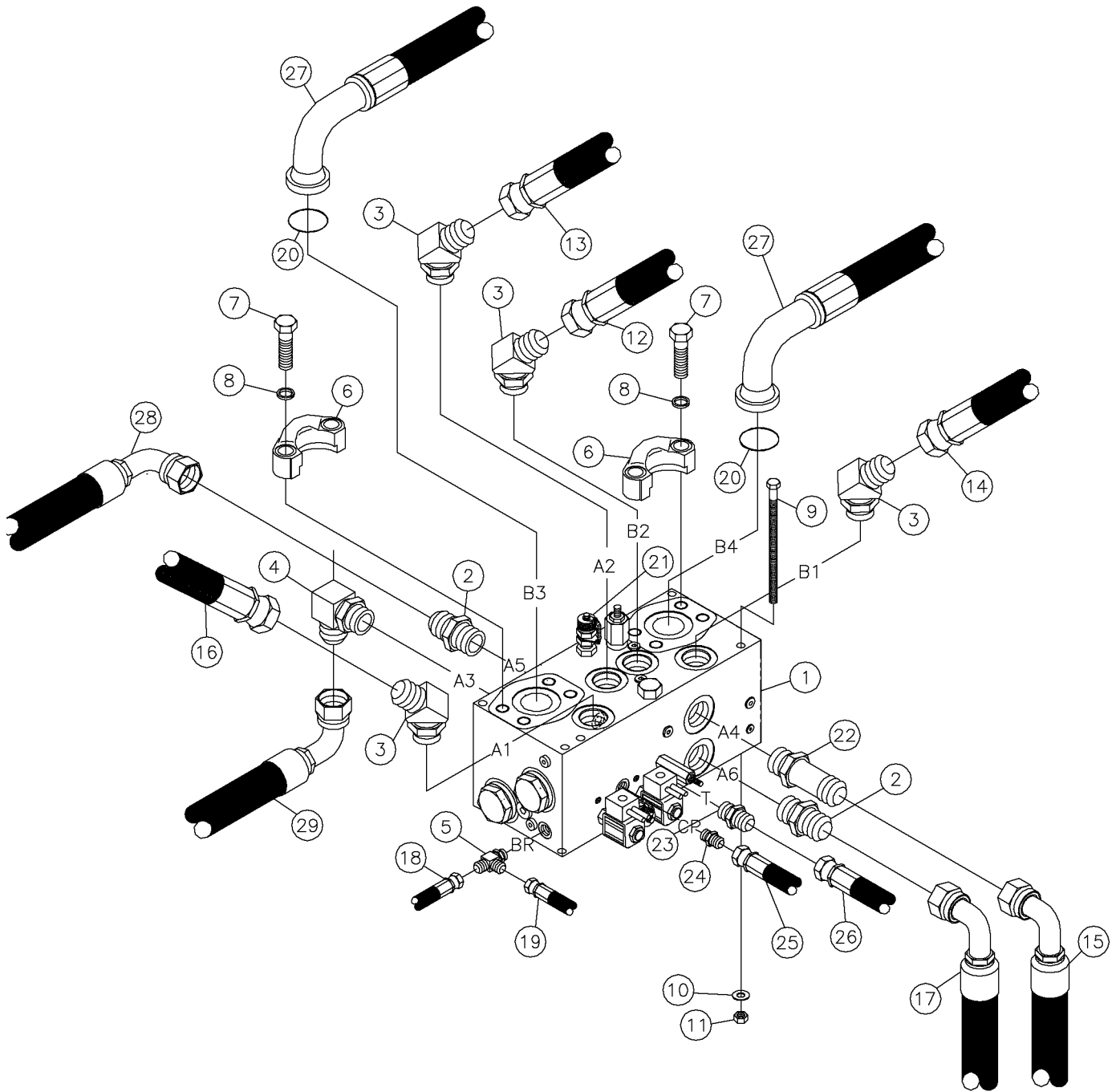

Hyd-Valve-Diverter Assy Fig 5-23r01

REF. NO.	*	PART NO.	DESCRIPTION	QTY.	REMARKS
		Revision Date	June, 2002		Update Drawing
1		277900001	VALVE - SELECTOR #9003178A	1	Breakdown Fig 12-3
2		60907001	FITTING-16M JICX16M STR ADAPT	2	
3		53835001	#16M O-RING-#16M JIC 45 DEG.	4	
4		61703001	16M X 16M JIC 90	1	
5		82930001	FIT-6MX4M JICX4M JIC (BCH) TEE	1	
6		72107001	FLANGE-1 1/2 CODE 62 H.D.	4	
7		238245001	BOLT 5/8" - 11 X 2 1/4 GR 8 HEX	8	
8		235715001	WASHER-5/8 SAE HARD ZINC PLTD	8	
9		354070	3/8-16X7" GRADE#5 HEX BOLT	4	
10		235713001	WASHER-3/8 SAE HARD ZINC PLTD	4	
11		235725001	NUT-3/8-16 GR8 ZINC PLTD	4	
12		296258395	HOSE - 1.00 X 40 16FS MEGA ST/ST G6K	1	
13		296258394	HOSE - 1.00 X 37 16FS MEGA ST/ST G6K	1	
14		296258391	HOSE - 1.00 X 48 16FS MEGA ST/ST G6K	1	
15		296258321	HOSE-HYD-1 X 22 16C62/16FS MEGA 90/90 G6K	1	
16		296258390	HOSE - 1.00 X 41 16FS MEGA ST/ST G6K	1	
17		296258320	HOSE-HYD-1 X 37 16C62/16FS MEGA 90/90 G6K	1	
18		53843357	HOSE-1/4X33 4FS JIC 3000 PSI	1	
19		242688001	HOSE-1/4X47 4FS JIC (M3KMTF)	1	
20		72897001	O RING-SQ. #24 FLANGE	2	
21		72056001	FITTING-TEST-6MORB-16MTP	3	
22		94161001	FITTING-16MJICX16MORING LONG	1	
23		67850001	8M X 10MJIC STR	1	
24		65565001	FITTING - 6M O-RING X 6M JIC ST.	1	
25		257521001	HOSE-HYD 3/8 X 100" 6FS JIC ST/90	1	
26		296256877	HOSE - .625 X 32 10 FS JIC ST/ST M3K	1	
27		296256876	HOSE - 1.50 X 93 24C62 45/30 G6K	2	
28		296258322	HOSE -HYD-1 X 70 16CD6260 - 16FSJ90	1	
29		296258319	HOSE-HYD-1 X 36 16C62/16FS MEGA 90/90 G6K	1	

Hyd-Valve-Diverter Assy Fig 5-23

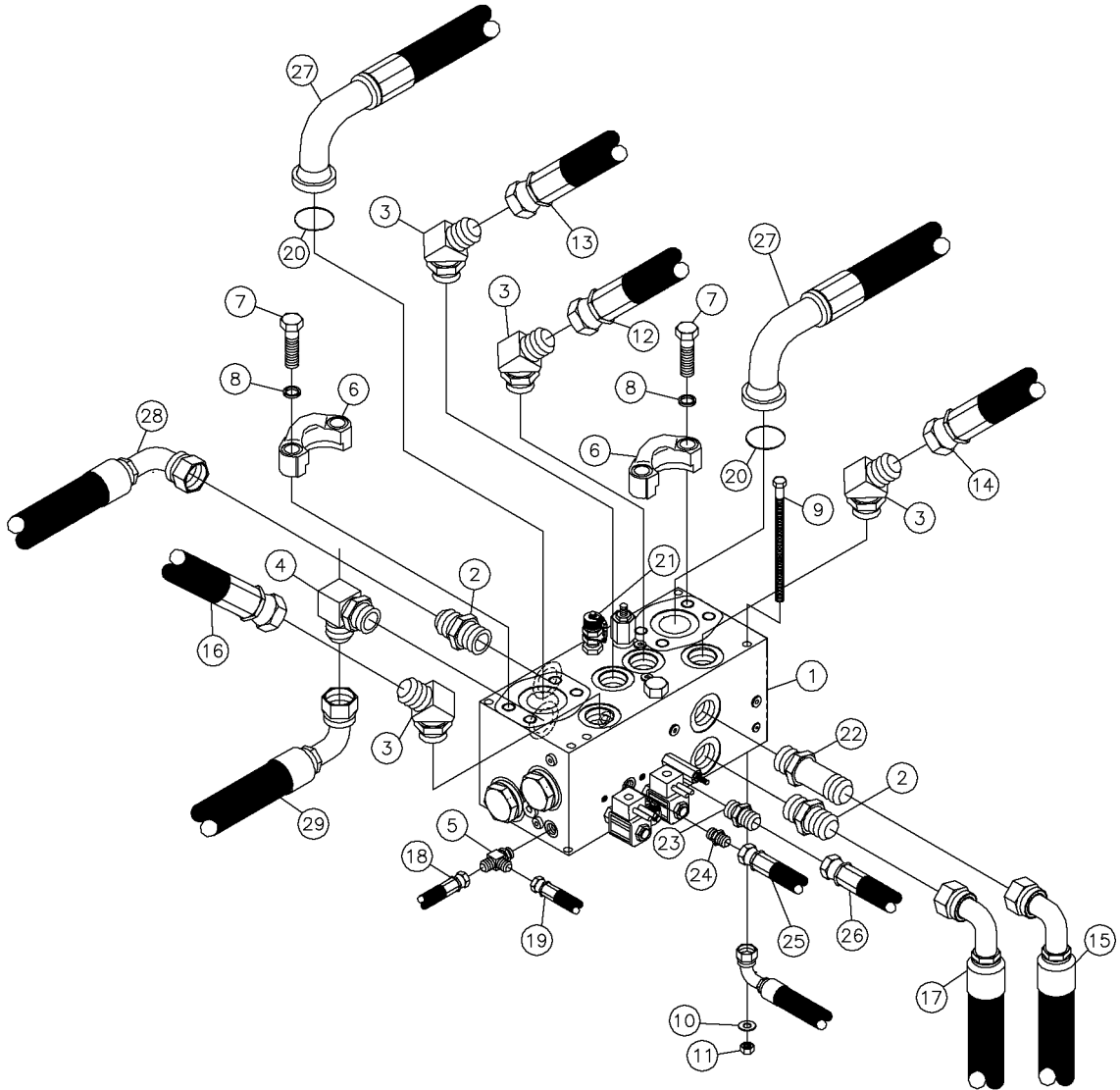

Hyd-Valve-Diverter Assy Fig 5-23

REF. NO.	*	PART NO.	DESCRIPTION	QTY.	REMARKS
1		277900001	VALVE - SELECTOR #9003178A	1	Breakdown Fig 12-3
2		60907001	FITTING-16M JICX16M STR ADAPT	2	
3		53835001	#16M O-RING-#16M JIC 45 DEG.	4	
4		61703001	16M X 16M JIC 90	1	
5		82930001	FIT-6MX4M JICX4M JIC (BCH) TEE	1	
6		72107001	FLANGE-1 1/2 CODE 62 H.D.	4	
7		238245001	BOLT 5/8" - 11 X 2 1/4 GR 8 HEX	8	
8		235715001	WASHER-5/8 SAE HARD ZINC PLTD	8	
9		354070	3/8-16X7" GRADE#5 HEX BOLT	4	
10		235713001	WASHER-3/8 SAE HARD ZINC PLTD	4	
11		235725001	NUT-3/8-16 GR8 ZINC PLTD	4	
12		296258395	HOSE - 1.00 X 40 16FS MEGA ST/ST G6K	1	
13		296258394	HOSE - 1.00 X 37 16FS MEGA ST/ST G6K	1	
14		296258391	HOSE - 1.00 X 48 16FS MEGA ST/ST G6K	1	
15		296258321	HOSE-HYD-1 X 22 16C62/16FS MEGA 90/90 G6K	1	
16		296258390	HOSE - 1.00 X 41 16FS MEGA ST/ST G6K	1	
17		296258320	HOSE-HYD-1 X 37 16C62/16FS MEGA 90/90 G6K	1	
18		53843357	HOSE-1/4X33 4FS JIC 3000 PSI	1	
19		242688001	HOSE-1/4X47 4FS JIC (M3KMTF)	1	
20		72897001	O RING-SQ. #24 FLANGE	2	
21		72056001	FITTING-TEST-6MORB-16MTP	3	
22		94161001	FITTING-16MJICX16MORING LONG	1	
23		67850001	8M X 10MJIC STR	1	
24		65565001	FITTING - 6M O-RING X 6M JIC ST.	1	
25		257521001	HOSE-HYD 3/8 X 100" 6FS JIC ST/90	1	
26		296256877	HOSE - .625 X 32 10 FS JIC ST/ST M3K	1	
27		296256876	HOSE - 1.50 X 93 24C62 45/30 G6K	2	
28		296258322	HOSE -HYD-1 X 70 16CD6260 - 16FSJ90	1	
29		296258319	HOSE-HYD-1 X 36 16C62/16FS MEGA 90/90 G6K	1	

Hyd-Valve-Catwalk Multi-Function Assy Fig 5-24r01

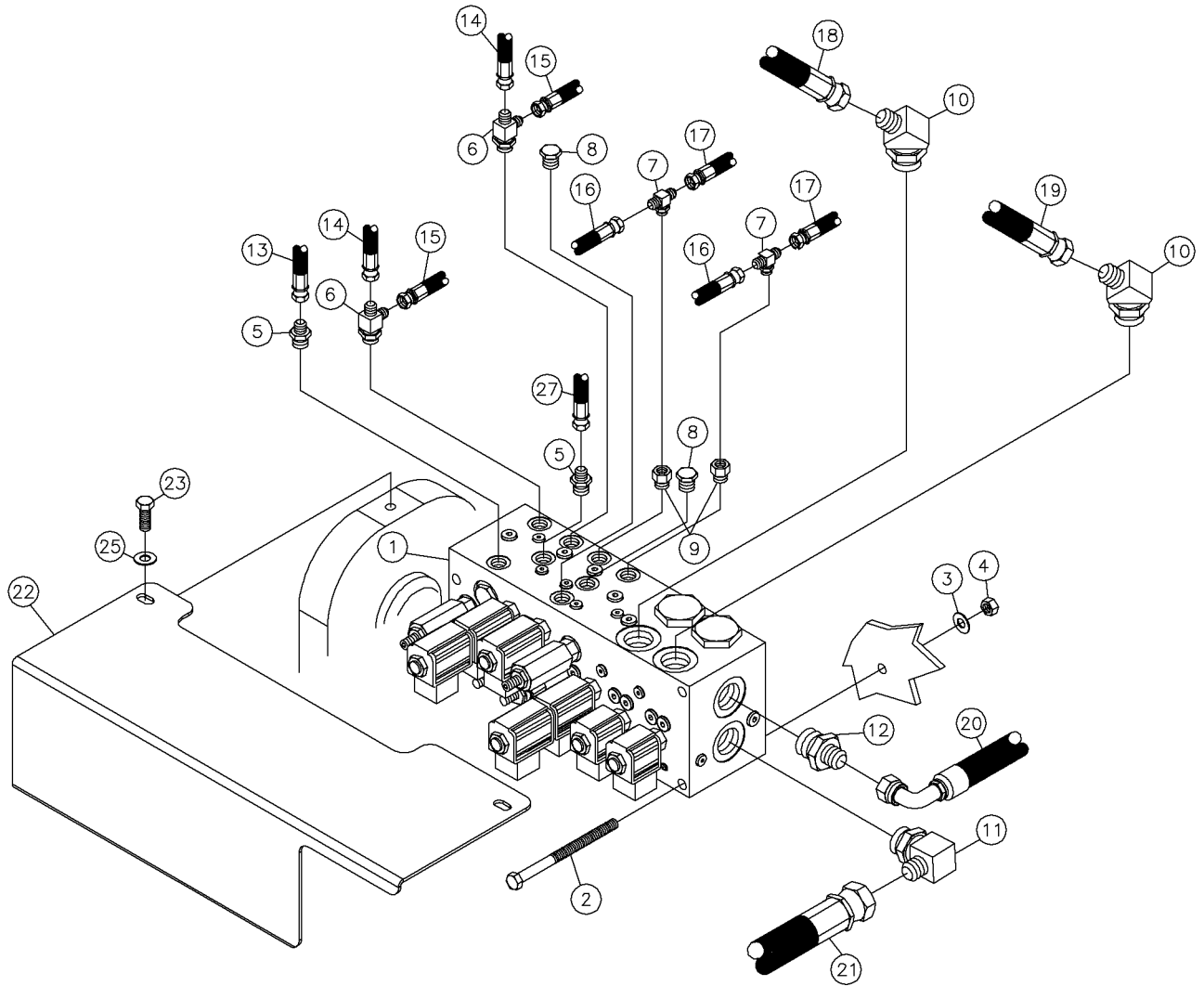

Hyd-Valve-Catwalk Multi-Function Assy Fig 5-24r01

REF. NO.	*	PART NO.	DESCRIPTION	QTY.	REMARKS
		Revision Date	June, 2002		Update In Illustration & Parts List.
1		277901001	VALVE - CATWALK #9S003176A	1	Breakdown Fig 12-15
2		275231001	BOLT-3/8-16X5 GR8 HEX ZINC PLT	4	
3		235713001	WASHER-3/8 SAE HARD ZINC PLTD	4	
4		235725001	NUT-3/8-16 GR8 ZINC PLTD	4	
5		57968001	FITTING-STR-4MJ-6MORB	2	
6		82930001	FIT-6MX4M JICX4M JIC (BCH) TEE	2	
7		81343001	4M (BCH)X4M JICX4M JIC TEE	2	
8		5553001	PLUG-#6M	2	
9		67291001	6MX4F SOLID REDUCER	2	
10		111487001	FITTING-12MX8M JIC 45 EL	2	
11		57949001	FITTING-12MX8M JIC 90 DEG. EL.	1	
12		53825001	#12M O-RING-#8M JIC ST.	1	
13		53843187	HOSE-1/4X44 4FS JIC 3000 PSI	1	
14		296256892	HOSE - .25 X 115 4FS JIC ST/ST M3K	2	
15		296256889	HOSE - .25 X 37 4FS JIC ST/ST M3K	2	
16		296256892	HOSE - .25 X 115 4FS JIC ST/ST M3K	2	
17		53843599	HOSE-1/4X40 4FS JIC 3000 PSI	2	
18		296258374	HOSE - .50 X 144 8FS JIC ST/90 M3K	1	
19		296258369	HOSE - .50 X 144 8FS JIC ST/ST M3K	1	
20		296256885	HOSE - .50 X 30 8FS JIC ST/90 M3K	1	
21		296256893	HOSE - .75 X 87 12 FS JIC ST/ST M3K	1	
22		296258430	SHIELD - MULTI FUNCTION VALVE	1	
23		235727001	BOLT-3/8-16X1 GR8 HEX ZINC PLT	3	
24		235713001	WASHER-3/8 SAE HARD ZINC PLTD	3	
25		53843591	HOSE-1/4X52 4FS JIC 3000 PSI	1	

Hyd-Valve-Catwalk Multi-Function Assy Fig 5-24

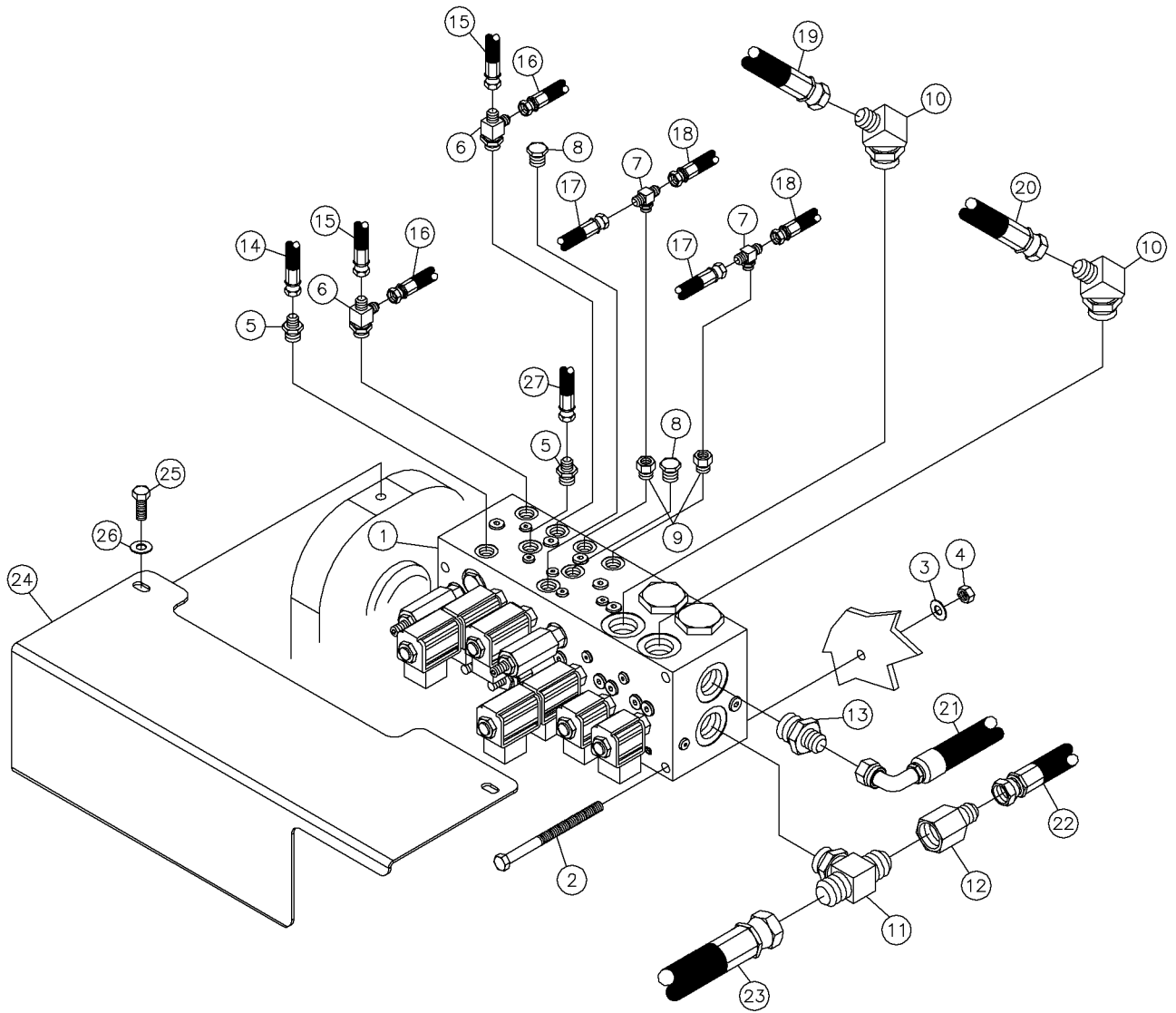

Hyd-Valve-Catwalk Multi-Function Assy Fig 5-24

REF. NO.	*	PART NO.	DESCRIPTION	QTY.	REMARKS
1		277901001	VALVE - CATWALK #9S003176A	1	Breakdown Fig 12-15
2		275231001	BOLT-3/8-16X5 GR8 HEX ZINC PLT	4	
3		235713001	WASHER-3/8 SAE HARD ZINC PLTD	4	
4		235725001	NUT-3/8-16 GR8 ZINC PLTD	4	
5		57968001	FITTING-STR-4MJ-6MORB	2	
6		82930001	FIT-6MX4M JICX4M JIC (BCH) TEE	2	
7		81343001	4M (BCH)X4M JICX4M JIC TEE	2	
8		5553001	PLUG-#6M	2	
9		67291001	6MX4F SOLID REDUCER	2	
10		111487001	FITTING-12MX8M JIC 45 EL	2	
11		70032001	12M BCH X 12M JICX12M JIC TEE	1	
12		59421001	12F JICX8M JIC ST REDUCER	1	
13		53825001	#12M O-RING-#8M JIC ST.	1	
14		53843187	HOSE-1/4X44 4FS JIC 3000 PSI	1	
15		296256892	HOSE - .25 X 115 4FS JIC ST/ST M3K	2	
16		296256889	HOSE - .25 X 37 4FS JIC ST/ST M3K	2	
17		296256892	HOSE - .25 X 115 4FS JIC ST/ST M3K	2	
18		53843599	HOSE-1/4X40 4FS JIC 3000 PSI	2	
19		296258374	HOSE - .50 X 144 8FS JIC ST/90 M3K	1	
20		296258369	HOSE - .50 X 144 8FS JIC ST/ST M3K	1	
21		296256885	HOSE - .50 X 30 8FS JIC ST/90 M3K	1	
22		296256899	HOSE - .50 X 337 8FS JIC ST/ST M3K	1	
23		296256893	HOSE - .75 X 87 12 FS JIC ST/ST M3K	1	
24		296258430	SHIELD - MULTI FUNCTION VALVE	1	
25		235727001	BOLT-3/8-16X1 GR8 HEX ZINC PLT	3	
26		235713001	WASHER-3/8 SAE HARD ZINC PLTD	3	
27		53843591	HOSE-1/4X52 4FS JIC 3000 PSI	1	

Hyd-Valve-3 Speed Flush Assy Fig 5-25x01

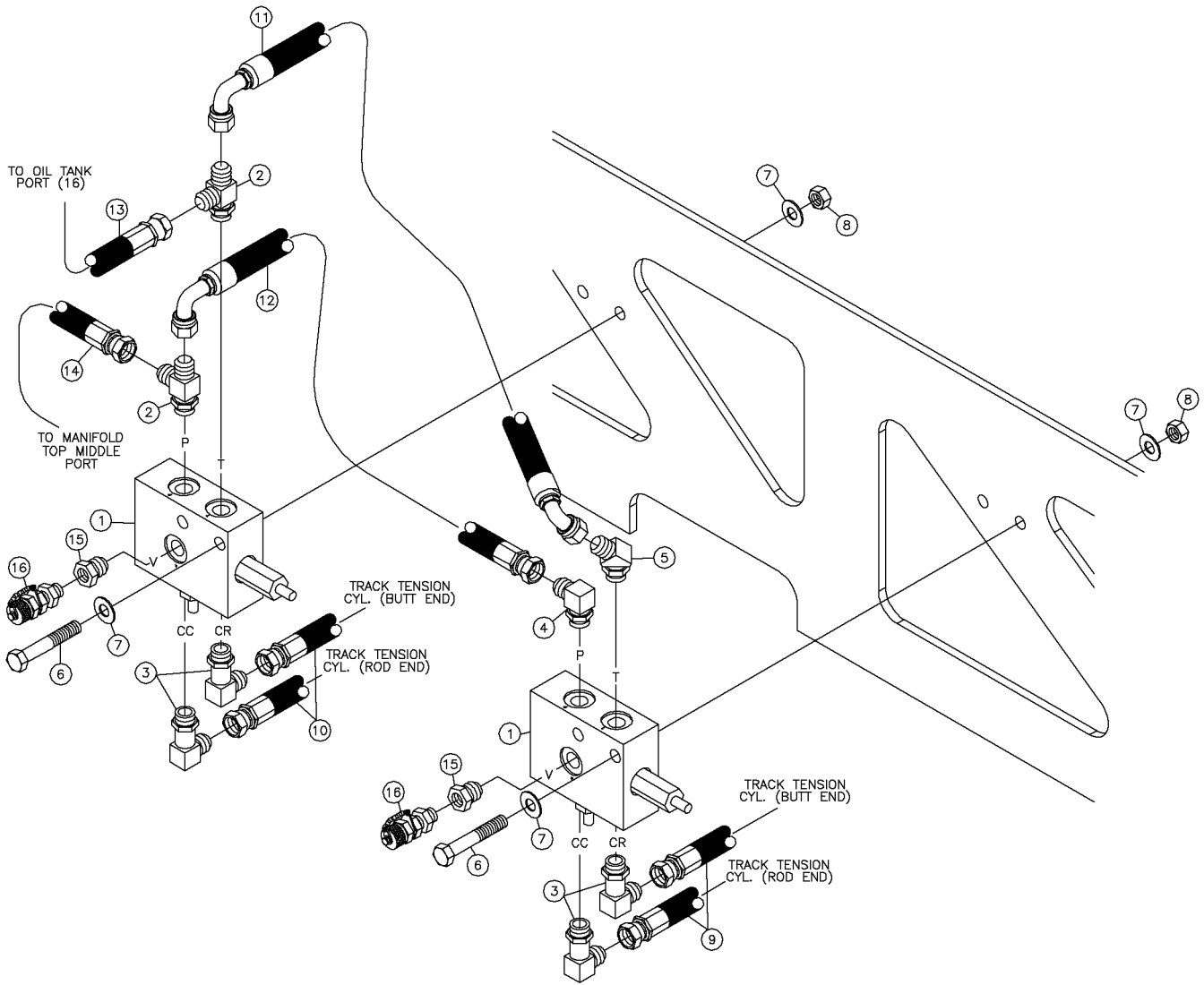

Hyd-Valve-3 Speed Flush Assy Fig 5-25x01

REF. NO.	*	PART NO.	DESCRIPTION	QTY.	REMARKS
		Revision Date	October, 2004		Addition To Manual
1		613619001	TENSION VALVE FV5333-ADJ	2	Breakdown Fig 12-52
2		81705001	FITTING-8MX8M JIC(RUN)X8M JIC	2	
3		278044001	FITTING -8MJ X 8MOR 90 - LONG	4	
4		53837001	FITTING - 8M O-RING X 8M JIC 90 DEGREE	1	
5		53834001	#8M O-RING-#8M JIC 45 DEG.	1	
6		235724001	BOLT-1/2-13X3 GR8 HEX ZINC PLT	4	
7		510337611	WASHER - FLATSTD - .50-.56X1.38-.11-YZ	8	
8		235731001	NUT-1/2-13 GR8 ZINC PLTD	4	
9		296267991	HOSE - HYD.50X27 8FSJST/ST 3000PSI	2	
10		53844197	HOSE-1/2X38 8FS JIC ST 3000	2	
11		296266404	HOSE-HYD .50 X 21.00 8FSJ90/45 3000PSI	1	
12		241799001	HOSE-1/2X22 90/ST M3KMTF	1	
13		53844663	HOSE 1/2X86 8FSJICST/90D 3000#	1	
14		244225001	HOSE-1/2X20 FSJIC ST/ST M3K	1	
15		81925001	FITTING-8MX6F STRAIGHT	2	
16		72056001	FITTING-TEST-6MORB-16MTP	2	

Hyd-Valve-3 Speed Flush Assy Fig 5-25

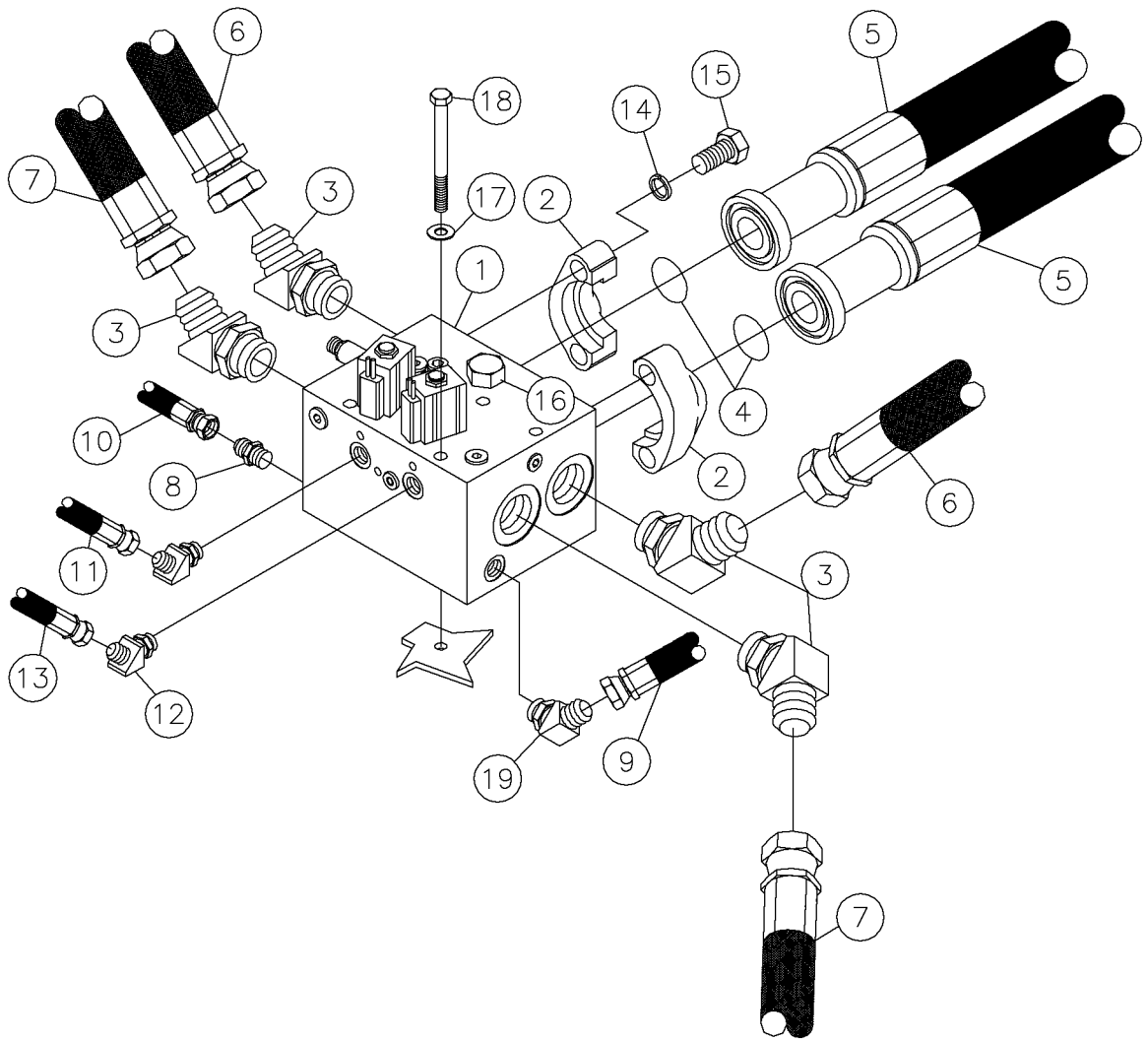

Hyd-Valve-3 Speed Flush Assy Fig 5-25

REF. NO.	*	PART NO.	DESCRIPTION	QTY.	REMARKS
1		277902001	VALVE - 3 - SPD FLUSH FV-5626-AGGJK	1	Breakdown Fig 12-6
2		72107001	FLANGE-1 1/2 CODE 62 H.D.	4	
3		53835001	#16M O-RING-#16M JIC 45 DEG.	4	
4		72897001	O RING-SQ. #24 FLANGE	2	
5		296258387	HOSE - 1.50 X 350 24C62 ST/ST G6K	2	
6		296258397	HOSE - 1.00 X 73 16C62/16FS JICM 90L/ST G6K	2	
7		296258399	HOSE - 1.00 X 40 16C62/16FS MEGA 90/ST G6K	2	
8		53824001	FITTING-#8M O-RING-#8M JIC ST.	1	
9		296256881	HOSE - .50 X 26 8FS JIC ST/ST M3K	2	
10		296256880	HOSE - .50 X 42 8FS JIC ST/90 M3K	1	
11		57940739	HOSE-3/8X27 6FS JIC 3000 PSI	1	
12		65563001	FITTING - 6M O-RING X 6M JIC 45 DEGREE	2	
13		57940543	HOSE-3/8X70 6FS 3000 PSI	1	
14		121820001	WASHER-5/8 HARDENED FLAT ZINC	4	
15		238245001	BOLT 5/8" - 11 X 2 1/4 GR 8 HEX	4	
16		56218001	PLUG-#8M	1	
17		235713001	WASHER-3/8 SAE HARD ZINC PLTD	4	
18		275231001	BOLT-3/8-16X5 GR8 HEX ZINC PLT	4	
19		53834001	#8M O-RING-#8M JIC 45 DEG.	1	

Hyd-Manifold-Rotation Gearbox Assy Fig 5-26

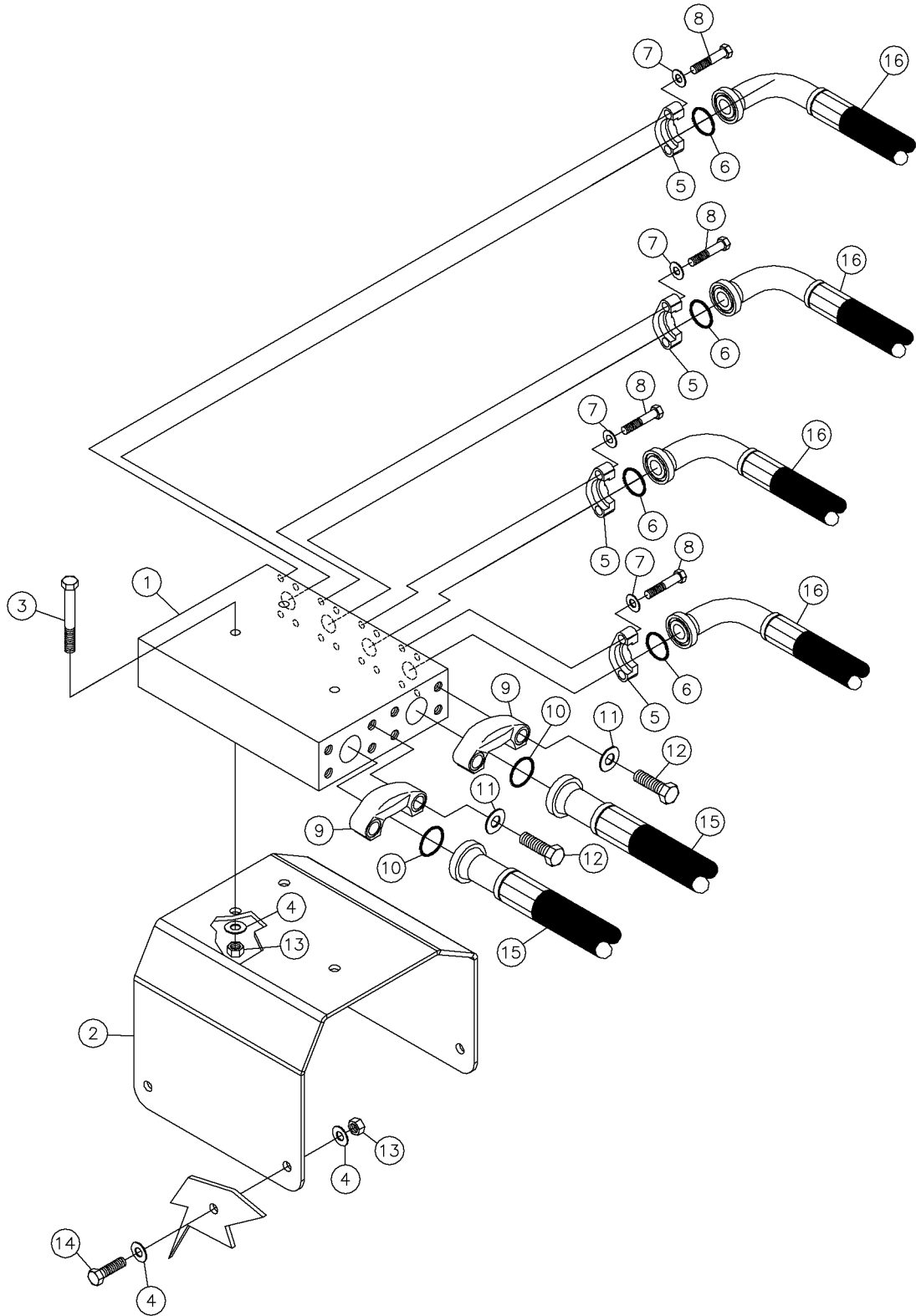

Hyd-Manifold-Rotation Gearbox Assy Fig 5-26

REF. NO.	*	PART NO.	DESCRIPTION	QTY.	REMARKS
1		288466001	MANIFOLD - ROTATION GEARBOX	1	
2		292898001	MOUNT - FLOW COMBINER MANIFOLD	1	
3		238244001	BOLT 1/2"-13 X 4"GR8 HEX Y/ZIN	3	
4		485025	WASHER-1/2 FLAT-HARDENED-ZINC	11	
5		67745001	SPLIT FLANGE HALF CODE 62/16	8	
6		72895001	O RING-SQ. #16 FLANGE	4	
7		250515001	7/16 HARD WASHER SAE Y/ZINC	16	
8		250507001	BOLT 7/16-14 X 1 3/4"GR8 HEX Y	16	
9		606170001	FLANGE - CODE 61 #24 SPLIT PR	4	
10		72897001	O RING-SQ. #24 FLANGE	2	
11		235715001	WASHER-5/8 SAE HARD ZINC PLTD	8	
12		145645001	BOLT - 5/8 - 11 X 2 GR.8 PLATED	8	
13		288466001	MANIFOLD - ROTATION GEARBOX	1	
13		235731001	NUT-1/2-13 GR8 ZINC PLTD	7	
14		235737001	BOLT-1/2-13X1 1/4 GR8 ZINC PLT	4	
15		296258387	HOSE - 1.50 X 350 24C62 ST/ST G6K	2	
16		296258382	HOSE - 1.00 X 60 16C62/16FS MEGA 90L/ ST G6K	4	

Hyd-High Pressure Filter Assy Fig 5-27

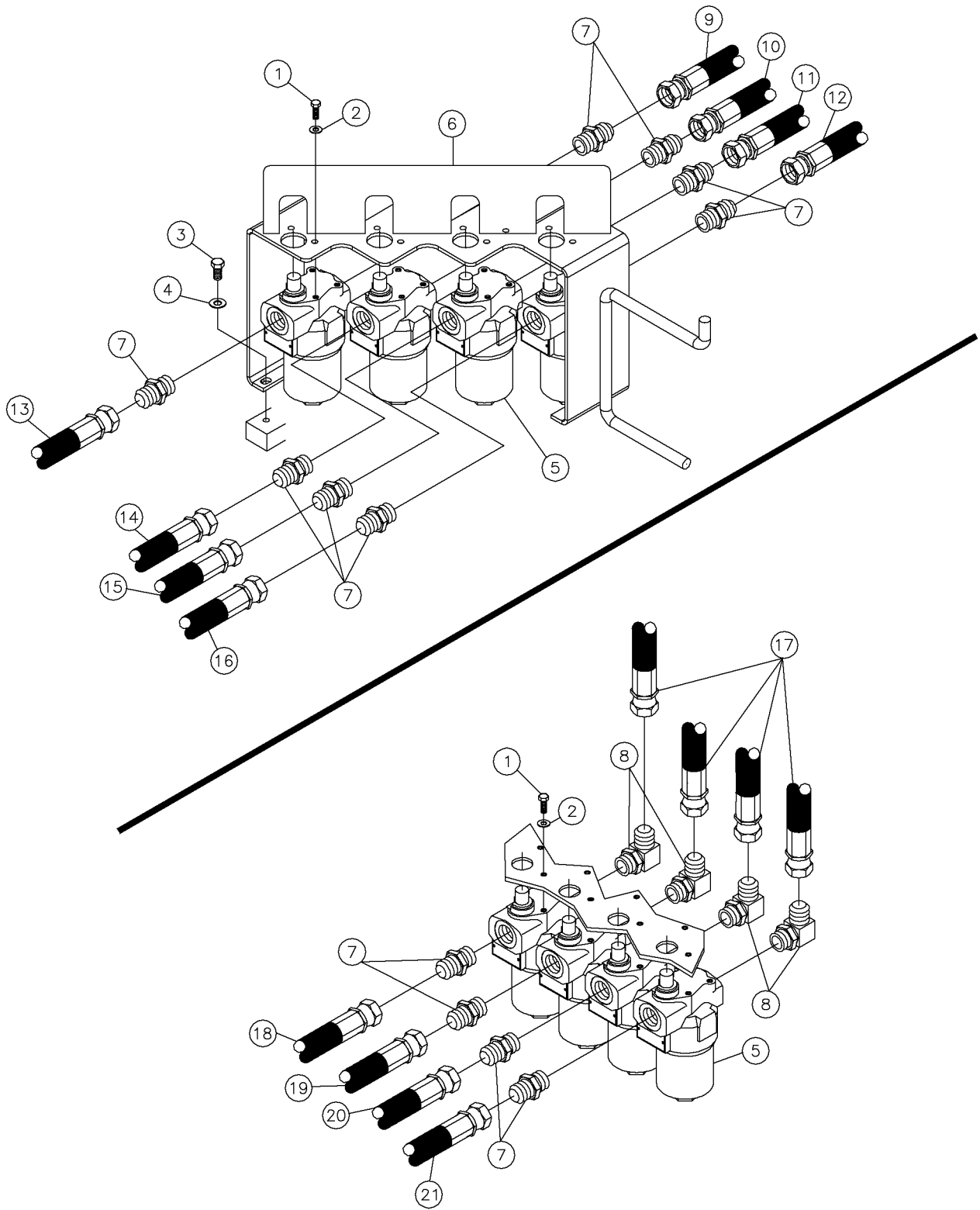

Hyd-High Pressure Filter Assy Fig 5-27

REF. NO.	*	PART NO.	DESCRIPTION	QTY.	REMARKS
1		235727001	BOLT-3/8-16X1 GR8 HEX ZINC PLT	32	
2		235713001	WASHER-3/8 SAE HARD ZINC PLTD	32	
3		235729001	SCREW-HCS-.50-13X1.00-GR8-YZ	4	
4		485025	WASHER-1/2 FLAT-HARDENED-ZINC	4	
5		296258288	FILTER - H.P. W/ INDICATOR - SAE 16	8	Breakdown Fig 12-29
6		292917001	SUBWELD - FILTER MOUNT	1	
7		60907001	FITTING-16M JICX16M STR ADAPT	12	
8		61703001	FITTING-16M X 16M JIC 90	4	
9		296258391	HOSE - 1.00 X 48 16FS MEGA ST/ST G6K	1	
10		296258390	HOSE - 1.00 X 41 16FS MEGA ST/ST G6K	1	
11		296258394	HOSE - 1.00 X 37 16FS MEGA ST/ST G6K	1	
12		296258395	HOSE - 1.00 X 40 16FS MEGA ST/ST G6K	1	
13		296256873	HOSE - 1.00 X 43 16C62/16FS MEGA 90SHORT/ST G6K	1	
14		296258388	HOSE - 1.00 X 54 16C62/16FS MEGA 90L/ST G6K	1	
15		296258392	HOSE - 1.00 X 50 16C62/16FS MEGA 90L/ST G6K	1	
16		296256874	HOSE - 1.00 X 53 16C62/16FS MEGA 90/ST G6K	1	
17		296258382	HOSE - 1.00 X 60 16C62/16FS MEGA 90L/ST G6K	4	
18		296258384	HOSE - 1.00 X 53 16C62/16FS MEGA 45/ST G6K	1	
19		296258380	HOSE - 1.00 X 4316C62/16FS MEGA 45/ST G6K	1	
20		296258381	HOSE - 1.00 X 36 16C62/16FS MEGA 45/ST G6K	1	
21		296258385	HOSE - 1.00 X 45 16C62/16FS MEGA 45/ST G6K	1	

Hyd-Oil Cooler Assy Fig 5-28

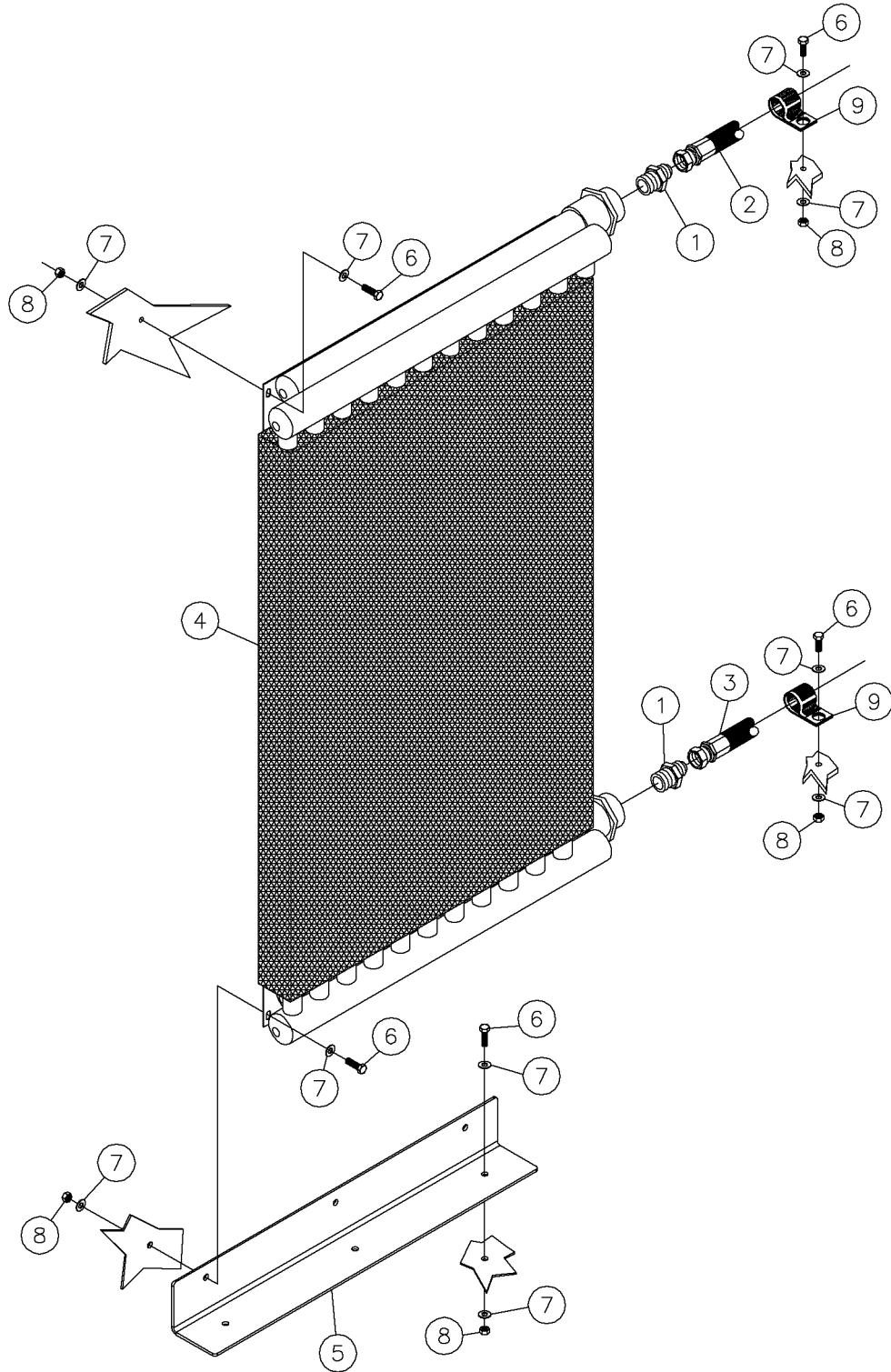

Hyd-Oil Cooler Assy Fig 5-28

REF. NO.	*	PART NO.	DESCRIPTION	QTY.	REMARKS
1		70008001	FITTING-16M X 12M JIC STR.	2	
2		296258379	HOSE - .75 X 247 12FS JIC ST/ST M3K	1	
3		296256905	HOSE - .75 X 206 12FS JIC 90/ST M3K	1	
4		228222001	COOLER-HYDAULIC OIL	1	
5		296256451	ANGLE - OIL COOLER MOUNT	1	
6		235736001	BOLT-3/8-16X1 1/4 ZINC PLTD	18	
7		235713001	WASHER-3/8 SAE HARD ZINC PLTD	36	
8		235725001	NUT-3/8-16 GR8 ZINC PLTD	18	
9		2595013	CLAMP-1"HOSE W/VINYL COAT	6	

Hyd-Oil Tank Assy Fig 5-29r02

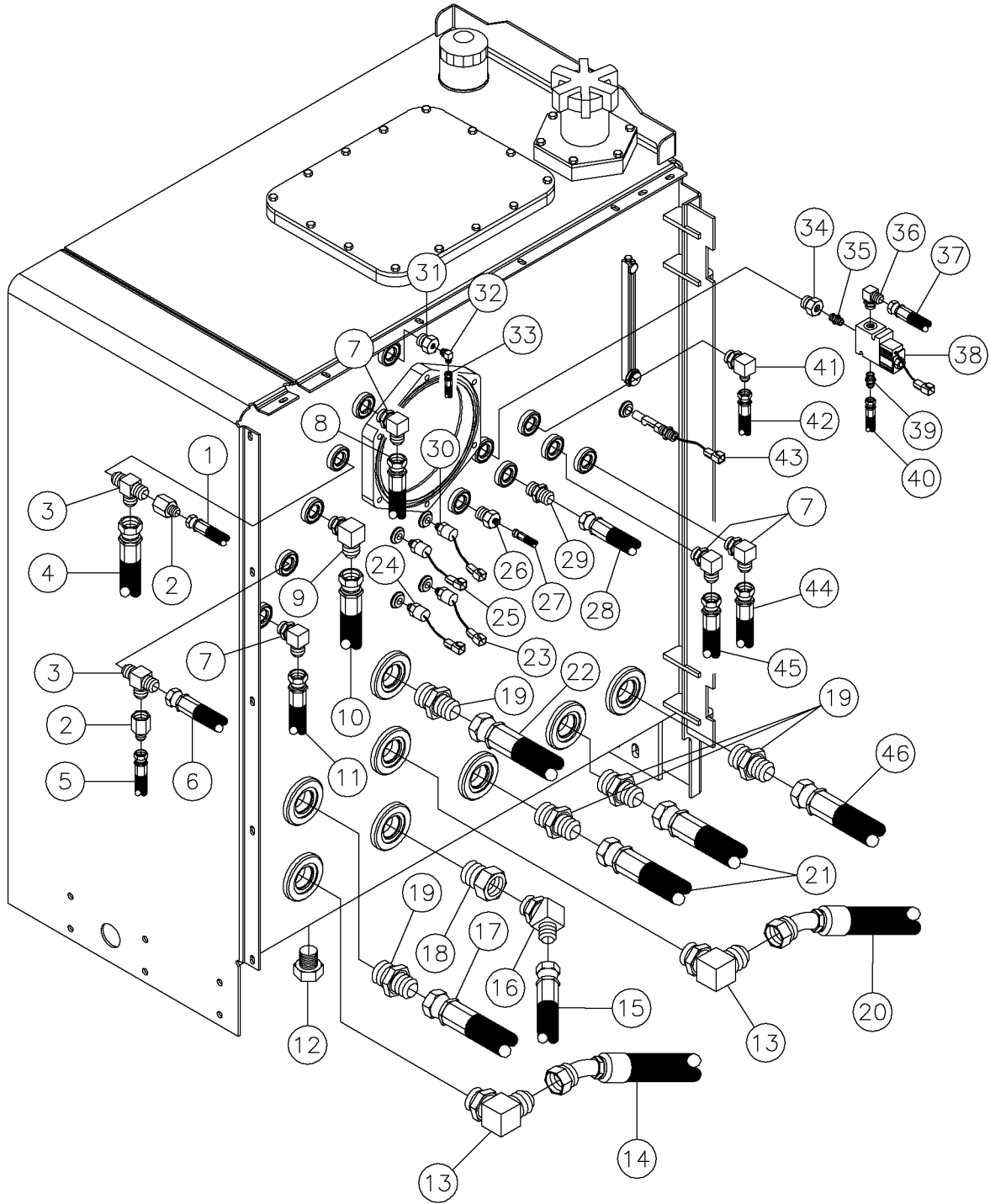

Hyd-Oil Tank Assy Fig 5-29r02

REF. NO.	*	PART NO.	DESCRIPTION	QTY.	REMARKS
		Revision Date	October, 2004		Update In Illustration & Parts List.
1		296056001	HOSE-HYD-.50 X 366 8FSJ ST/903KPSI BNS	1	
2		59421001	12F JICX8M JIC ST REDUCER FITTING	2	
3		59420001	12 JICX12M ADJ. STR THRD RUN TEE	2	
4		296070001	HOSE-HYD-.75 X 366 12FSJ-ST/12FSJ-ST M3K	1	
5		53844663	HOSE 1/2X86 8FSJICST/90D 3000#	1	
6		296256878	HOSE - .75 X 91 12 FS JIC ST/ST M3K	1	
7		59410001	FITTING-90-12MJ-12MORBA	4	
8		53845289	HOSE-3/4X43 12FS JIC 3000 PSI	1	
9		65571001	12M X 16M JIC 90 DEGREE	1	
10		296270797	HOSE-HYD-1.00X526-16FSJ-ST/ST-M3K	1	
11		296256893	HOSE - .75 X 87 12 FS JIC ST/ST M3K	1	
12		117006001	FITTING-MAGNETIC PLUG 7674031	1	
13		85668001	FITTING-24MORINGX20MJIC 90 EL	2	
14		296258409	HOSE - 1.25 X 20 20FS 45/ST G4H	1	
15		296016001	HOSE-HYD-1X36.0-16FSJ ST/ST 200PSI	1	
16		276383001	FITTING-16JIC/20 ORING 45 ELBW	1	
17		296258414	HOSE - 1.25 X 38 20FS ST/ST G4H	1	
18		85659001	FITTING-24M ORINGX20F ORINGSTR	1	
19		85660001	FITTING-24MORINGX20M JIC STR.	5	
20		296258410	HOSE - 1.25 X 24 20FS JIC 45/ST G4H	1	
21		296258411	HOSE - 1.25 X 28 20FSJIC ST/ST G4H	2	
22		296258413	HOSE - 1.25 X 47 20FS ST/ST G4H	1	
23		283048001	PRESSURE-SWITCH-HYDRAULIC OIL RETURN	1	
24		283050001	TEMPERATURE SWITCH-HYDRAULIC OIL	1	
25		283047001	TEMPERATURE SWITCH-HYDRAULIC OIL	1	
26		64168001	12MX6 JIC M STR.	1	
27		57940695	HOSE-3/8X36 6FSJICST 3000# MTF	1	
28		53845439	HOSE-3/4X32 12FS JIC 3000 PSI	1	
29		53828001	FITTING - 12M O-RING 12M JIC ST	1	
30		283049001	TEMPURATURE SWITCH - HYDRAULIC OIL	1	
31		120890001	FITTING-STR-12MORB-4FORB	1	
32		59423001	FIT-4M JICX4M ADJ.90 DEG.ELBOW	1	
33		296261579	HOSE-HYD-.25X186-4FSJ-90/ST-3000PSI	1	
34		117452001	FITTING-STR-12MORB-6FORB	1	
			Continued On Next Page		

Hyd-Oil Tank Assy Fig 5-29r01

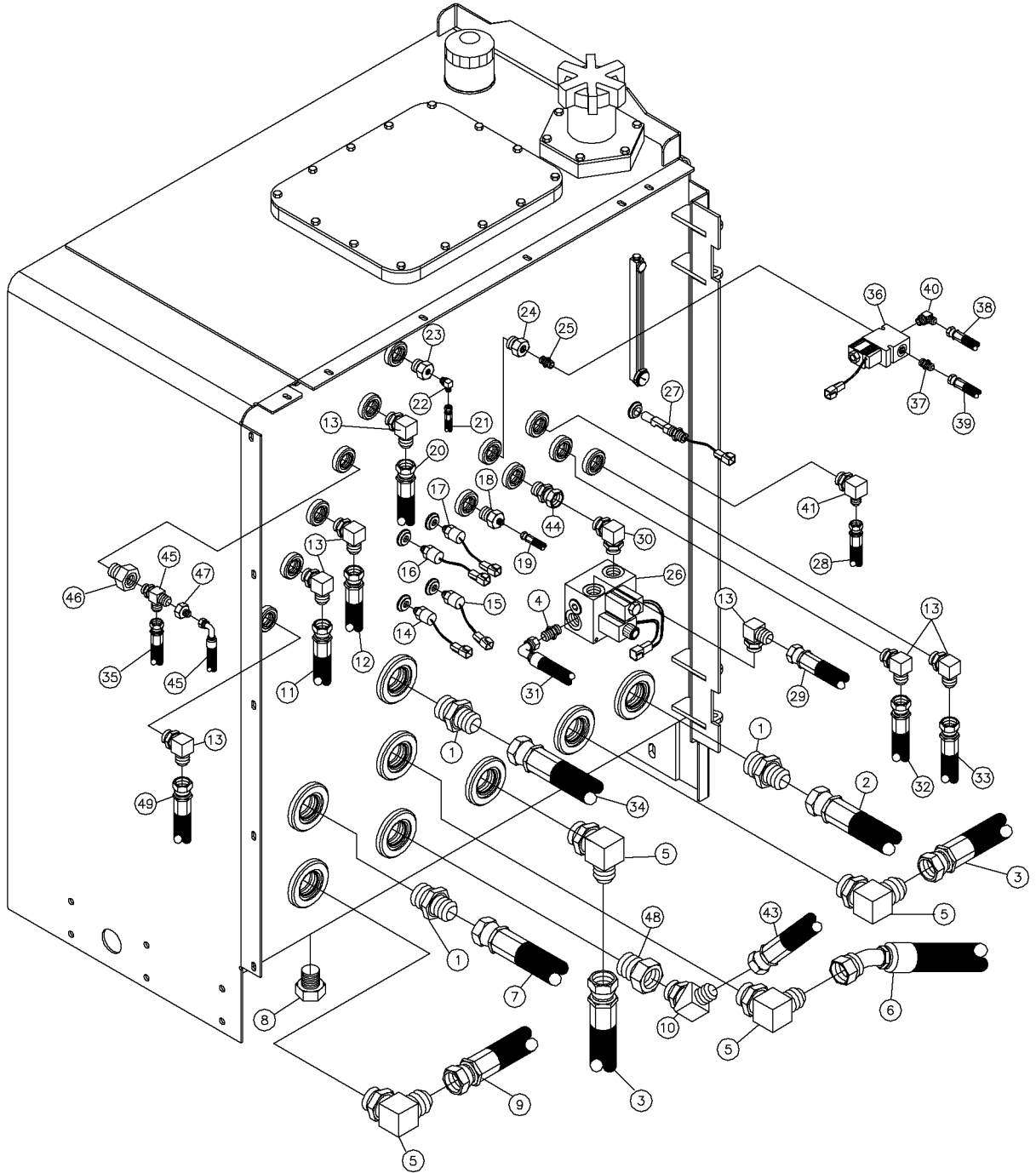

Hyd-Oil Tank Assy Fig 5-29r01

REF. NO.	*	PART NO.	DESCRIPTION	QTY.	REMARKS
		Revision Date	June, 2002		Update In Illustration & Parts List.
1		85660001	FITTING-24MORINGX20M JIC STR.	3	
2		296033001	HOSE-HYD 1.25X90 20FSJ ST/ST 200PSI	1	
3		296015001	HOSE-HYD-1.25X22.5 20FSJ ST/90-200PSI	2	
4		53828001	FITTING- #12M O-RING-#12M JIC ST.	1	
5		85668001	FITTING-24MORINGX20MJIC 90 EL	4	
6		296011001	HOSE-HYD-1.25X19.0 20FSJ ST/90 200PSI	1	
7		296258414	HOSE - 1.25 X 38 20FS ST/ST G4H	1	
8		117006001	FITTING-MAGNETIC PLUG 7674031	1	
9		296010001	HOSE-HYD-1.25X14.5 20FSJ ST/90-200PSI	1	
10		276383001	FITTING-16JIC/20 ORING 45 ELBW	1	
11		296256878	HOSE - .75 X 91 12 FS JIC ST/ST M3K	2	
12		296032001	HOSE-HYD 1.00X484 16FSJ ST/ST 200PSI	1	
13		59410001	FITTING-12M JICX12M ADJ. 90 DEG.ELBOW	6	
14		283050001	TEMPERATURE SWITCH-HYDRAULIC OIL	1	
15		283048001	PRESSURE-SWITCH-HYDRAULIC OIL RETURN	1	
16		283047001	TEMPERATURE SWITCH-HYDRAULIC OIL	1	
17		283049001	TEMPURATURE SWITCH - HYDRAULIC OIL	1	
18		64168001	FITTING-12MX6 JIC M STR.	1	
19		57940695	HOSE-3/8X36 6FSJICST 3000# MTF	1	
20		53845289	HOSE-3/4X43 12FS JIC 3000 PSI	1	
21		296261579	HOSE-HYD-.25X186-4FSJ-90/ST-3000PSI	1	
22		59423001	FIT-4M JICX4M ADJ.90 DEG.ELBOW	1	
23		120890001	FITTING-STR-12MORB-4FORB	1	
24		117452001	FITTING-STR-12MORB-6FORB	1	
25		108909001	FITTING-6M HEX NIPPLE	1	
26		277903001	VALVE - HEATER - COOLER - FILTER - MANIFOLD	1	Breakdown Fig 12-8
27		283052001	SWITCH-HYDRAULIC OIL LEVEL	1	
28		289128001	HOSE - 1/2 X 120 8FSJIC ST/ST 3000 PSI	1	
29		53845187	HOSE-3/4X24 12FS JIC 2500 PSI	1	
30		238219001	FITTING 12M X 12M O-RING 90	1	
31		296256905	HOSE - .75 X 206 12FS JIC 90/ST M3K	1	
32		296258379	HOSE - .75 X 247 12FS JIC ST/ST M3K	1	
33		53845435	HOSE-3/4X26 12FS JIC 3000 PSI	1	
34		296258413	HOSE - 1.25 X 47 20FS ST/ST G4H	1	
			Continued On Next Page		

Hyd-Oil Tank Assy (Continued) Fig 5-29r02

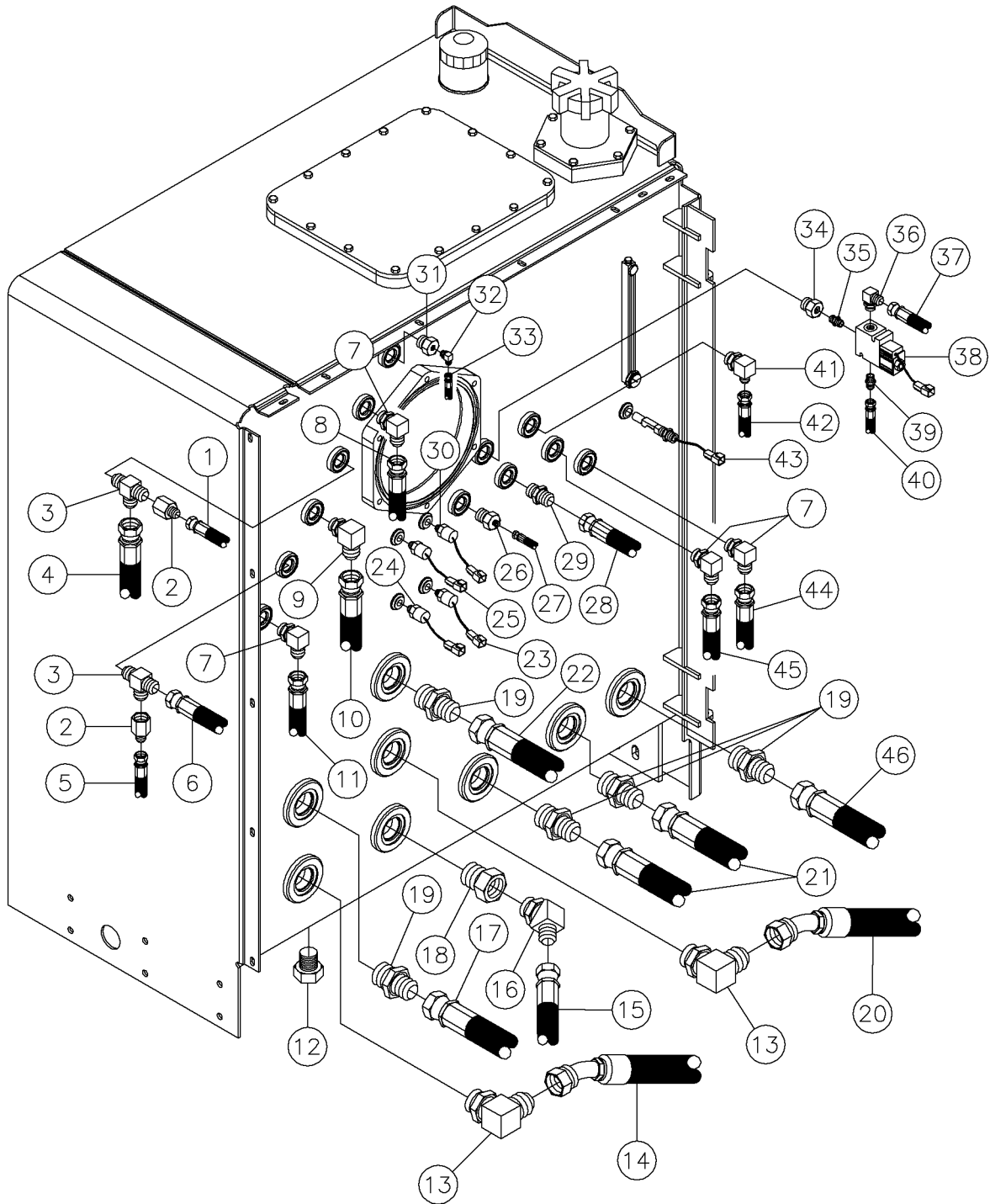

Hyd-Oil Tank Assy (Continued) Fig 5-29r02

REF. NO.	*	PART NO.	DESCRIPTION	QTY.	REMARKS
		Revision Date	October, 2004		Update In Illustration & Parts List.
35		108909001	FITTING-6M HEX NIPPLE	1	
36		59426001	FITTING - 90-6MJ-6MORBA	1	
37		296256871	HOSE - .375 X 26 6FS JIC ST/90 M3K	1	
38		277905001	VALVE -2P- 3W 24V #9S003180A	1	BREAKDOWN FIG. 12-4
39		65565001	FITTING - 6M O-RING X 6M JIC ST.	1	
40		296256872	HOSE - .375 X 540 6FS JIC ST/ST M3K	1	
41		57949001	FITTING-12MX8M JIC 90 DEG. EL.	1	
42		289128001	HOSE - 1/2 X 120 8FSJIC ST/ST 3000 PSI	1	
43		283052001	SWITCH-HYDRAULIC OIL LEVEL	1	
44		53845435	HOSE-3/4X26 12FS JIC 3000 PSI	1	
45		296258379	HOSE - .75 X 247 12FS JIC ST/ST M3K	1	
46		296258415	HOSE - 1.25 X 84 20FS ST/ST G4H	1	

Hyd-Oil Tank Assy (Continued) Fig 5-29r01

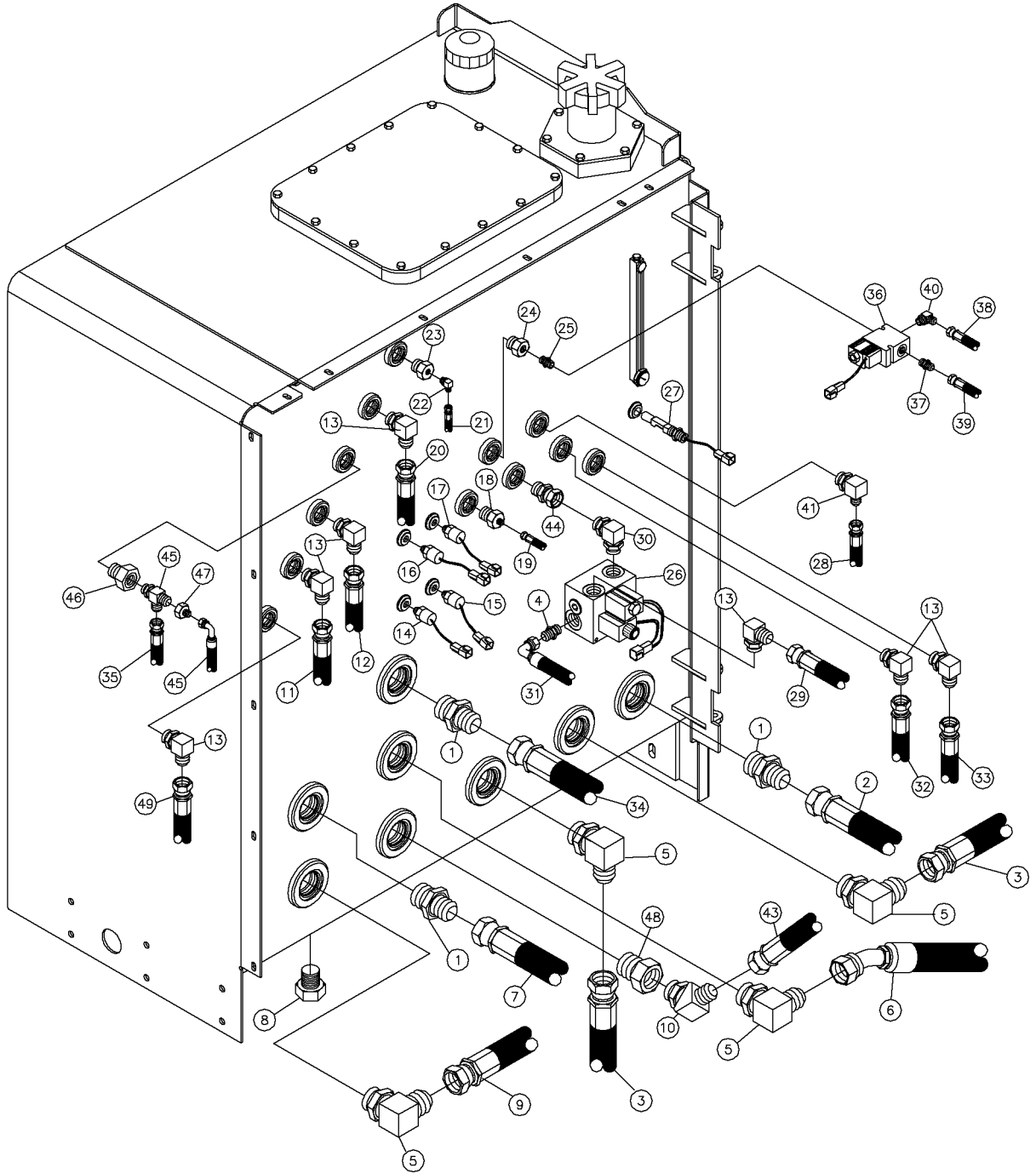

Hyd-Oil Tank Assy (Continued) Fig 5-29r01

REF. NO.	*	PART NO.	DESCRIPTION	QTY.	REMARKS
		Revision Date	June, 2002		Update In Illustration & Parts List.
35		296070001	HOSE-HYD-.63 X 366 10FSJ ST/ST 3000PSI	1	
36		277905001	VALVE -2P- 3W 24V #9S003180A	1	Breakdown Fig 12-4
37		65565001	FITTING - 6M O-RING X 6M JIC ST.	1	
38		296256871	HOSE - .375 X 26 6FS JIC ST/90 M3K	1	
39		296256872	HOSE - .375 X 540 6FS JIC ST/ST M3K	1	
40		59426001	FITTING - 6M JIC X 6M O-RING ADJ 90 ELBOW	1	
41		57949001	FITTING-12MX8M JIC 90 DEG. EL.	1	
42		680001	FITTING-12 M X 3/4 FS ST. ADAPTER	1	
43		296016001	HOSE-HYD-1X36.0-16FSJ ST/ST 200PSI	1	
44		296056001	HOSE-HYD-.50 X 366 8FSJ ST90 3000PSI	1	
45		100873001	FITTING-10MX10MJIC RUN TEE	1	
46		682001	FITTING- 12 M X 10 F SOLID ADAPT.	1	
47		86670001	FITTING-ADAPT 10FJICX8MJIC RED	1	
48		85659001	FITTING-24M ORINGX20F ORINGSTR	1	
49		296256893	HOSE - .75 X 87 12 FS JIC ST/ST M3K	1	

Hyd-Oil Tank Assy Fig 5-29

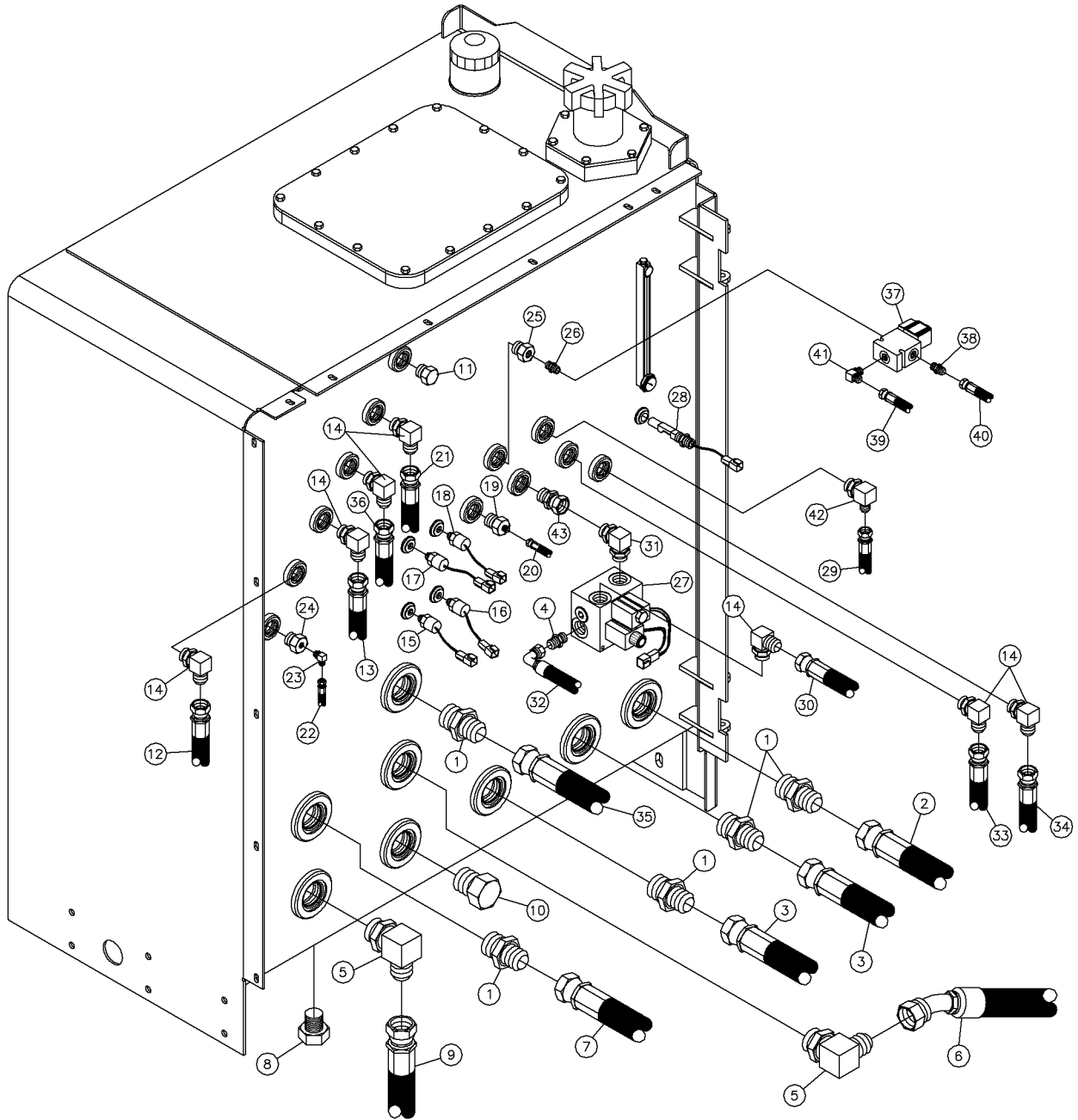

Hyd-Oil Tank Assy Fig 5-29

REF. NO.	*	PART NO.	DESCRIPTION	QTY.	REMARKS
1		85660001	FITTING-24MORINGX20M JIC STR.	5	
2		296258415	HOSE - 1.25 X 84 20FS ST/ST G4H	1	
3		296258411	HOSE - 1.25 X 28 20FSJIC ST/ST G4H	2	
4		53828001	#12M O-RING-#12M JIC ST.	1	
5		85668001	FITTING-24MORINGX20MJIC 90 EL	1	
6		296258410	HOSE - 1.25 X 24 20FS JIC 45/ST G4H	1	
7		296258414	HOSE - 1.25 X 38 20FS ST/ST G4H	1	
8		117006001	FITTING-MAGNETIC PLUG 7674031	2	
9		296258409	HOSE - 1.25 X 20 20FS 45/ST G4H	1	
10		73065001	FITTING-24M PLUG	1	
11		67570001	PLUG - 12M	1	
12		296256878	HOSE - .75 X 91 12 FS JIC ST/ST M3K	1	
13		296256900	HOSE - .75 X 508 12 FS JIC ST/ST M3K	1	
14		59410001	FITTING-12M JICX12M ADJ. 90 DEG.ELBOW	7	
15		283050001	TEMPERATURE SWITCH-HYDRAULIC OIL	1	
16		283048001	PRESSURE-SWITCH-HYDRAULIC OIL RETURN	1	
17		283047001	TEMPERATURE SWITCH-HYDRAULIC OIL	1	
18		283049001	TEMPURATURE SWITCH - HYDRAULIC OIL	1	
19		64168001	12MX6 JIC M STR.	1	
20		57940695	HOSE-3/8X36 6FSJICST 3000# MTF	1	
21		53845289	HOSE-3/4X43 12FS JIC 3000 PSI	1	
22		296261579	HOSE-HYD-.25X186-4FSJ-90/ST-3000PSI	1	
23		59423001	FIT-4M JICX4M ADJ.90 DEG.ELBOW	1	
24		120890001	FITTING-STR-12MORB-4FORB	1	
25		117452001	FITTING-STR-12MORB-6FORB	1	
26		108909001	FITTING-6M HEX NIPPLE	1	
27		277903001	VALVE - HEATER - COOLER - FILTER - MANIFOLD	1	Breakdown Fig 12-8
28		283052001	SWITCH-HYDRAULIC OIL LEVEL	1	
29		289128001	HOSE - 1/2 X 120 8FSJIC ST/ST 3000 PSI	1	
30		53845187	HOSE-3/4X24 12FS JIC 2500 PSI	1	
31		238219001	FITTING 12M X 12M O-RING 90	1	
32		296256905	HOSE - .75 X 206 12FS JIC 90/ST M3K	1	
33		296258379	HOSE - .75 X 247 12FS JIC ST/ST M3K	1	
34		53845435	HOSE-3/4X26 12FS JIC 3000 PSI	1	
35		296258413	HOSE - 1.25 X 47 20FS ST/ST G4H	1	
36		296256893	HOSE - .75 X 87 12 FS JIC ST/ST M3K	1	
37		277905001	VALVE -2P- 3W 24V #9S003180A	1	Breakdown Fig 12-4
38		65565001	FITTING - 6M O-RING X 6M JIC ST.	1	
39		296256871	HOSE - .375 X 26 6FS JIC ST/90 M3K	1	
40		296256872	HOSE - .375 X 540 6FS JIC ST/ST M3K	1	
41		59426001	FITTING - 6M JIC X 6M O-RING ADJ 90 ELBOW	1	
42		59409001	10M JICX12M ADJ. 90DEG.ELBOW REF 70029-001-1	1	
43		680001	FITTING-12 M X 3/4 FS ST. ADAPTER	1	

Hyd-Oil Tank Assy Fig 5-30r01

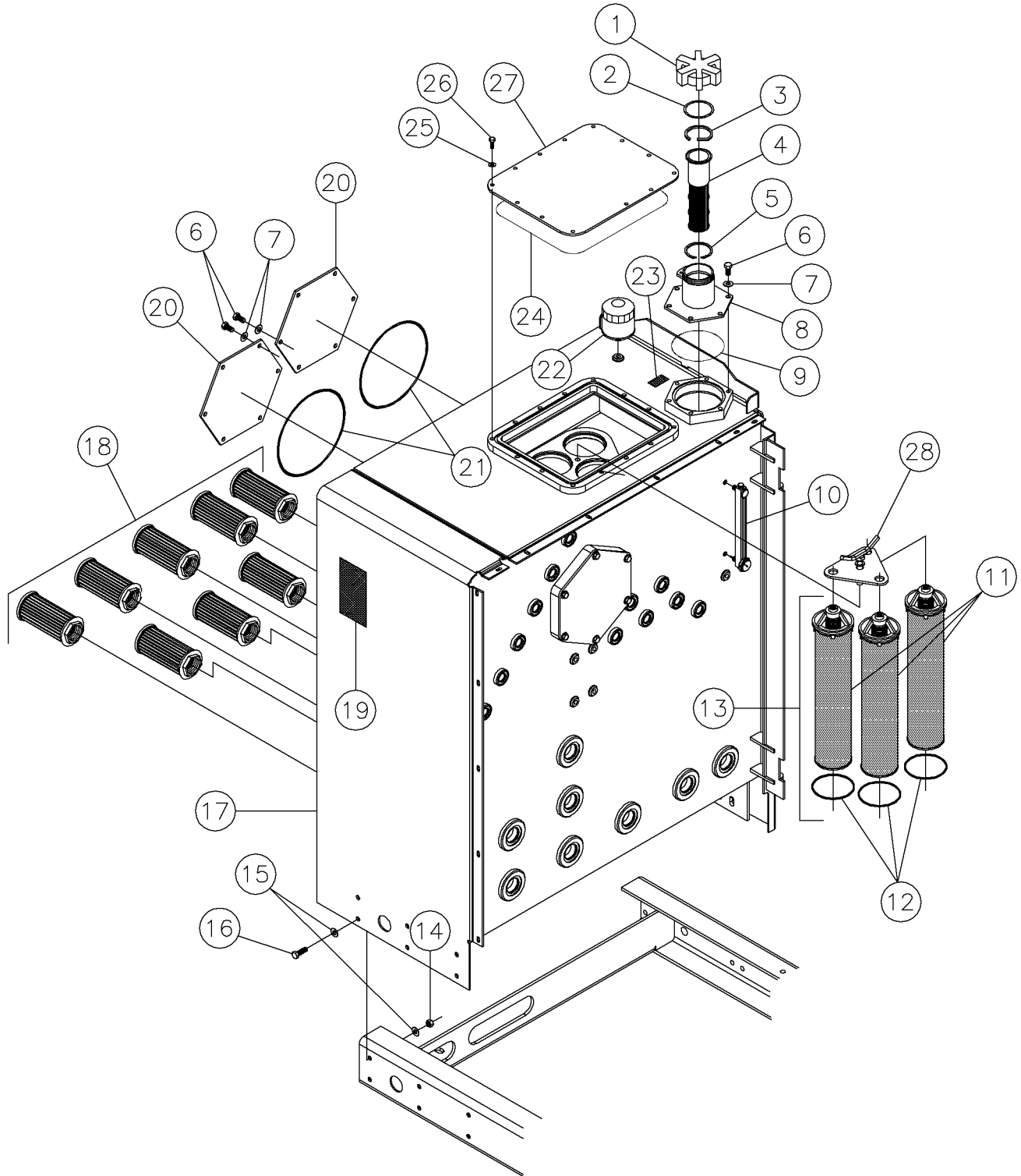

Hyd-Oil Tank Assy Fig 5-30r01

REF. NO.	*	PART NO.	DESCRIPTION	QTY.	REMARKS
		Revision Date	October, 2004		Update In Illustration & Parts List.
1		106852001	HYDRAULIC CAP	1	
2		111468001	GASKET	1	
3		111472001	SNAP RING-INTERNAL	1	
4		111467001	STRAINER-FUEL GET FROM TRACK DIV.	1	
5		111471001	SNAP RING-INTERNAL	1	
6		250539001	BOLT-7/16-14 X 1 GR8 HEX Y/ZI	24	
7		510337609	WASHER-FLATSTD-.44-.50X1.25-.08-YZ	24	
8		288866001	FILTER /CLEANOUT SUBWELD	1	
9		78543001	O-RING AS-357 B46	1	
10		113092001	GAUGE-10" LIQUID LEVEL	1	
11		609133003	FILTER ELEMENT	3	
12		89671007	SEAL	3	
13		609134001	FILTER ASSEMBLY-HYDRAULIC	3	
14		235731001	NUT-1/2-13 GR8 ZINC PLTD	10	
15		485025	WASHER-1/2 FLAT-HARDENED-YZ	20	
16		235721001	BOLT-1/2-13X1 1/2 GR8 ZINC PLT	10	
17		288877001	TANK WELDMENT	1	
18		113091001	FILTER-SUMP STRAINER	8	
19		7000A393	DECAL - DANGER	1	Domestic
		700IA393	DECAL - DANGER	1	International
20		116931001	COVER - CLEANOUT	3	
21		78544001	O-RING AS-378 B46	3	
22		108475001	FILTER-BREATHER1/2NPTW/ORELIEF	1	
23		2326756	DECAL-HYDRAULIC OIL	1	Domestic
		2326I756	DECAL-HYDRAULIC FLUID	1	International
24		288980001	O-RING-OIL TANK COVER	1	
25		235713001	WASHER - FLATSTRL - .38 - .41 X .81 - .06-YA-A325	14	
26		235727001	BOLT-3/8-16X1 GR8 HEX ZINC PLT	14	
27		288859001	PLATE - FILTER ACCESS	1	
28		296256861	LOCK FILTER PLATE	1	

Hyd-Oil Tank Assy Fig 5-30

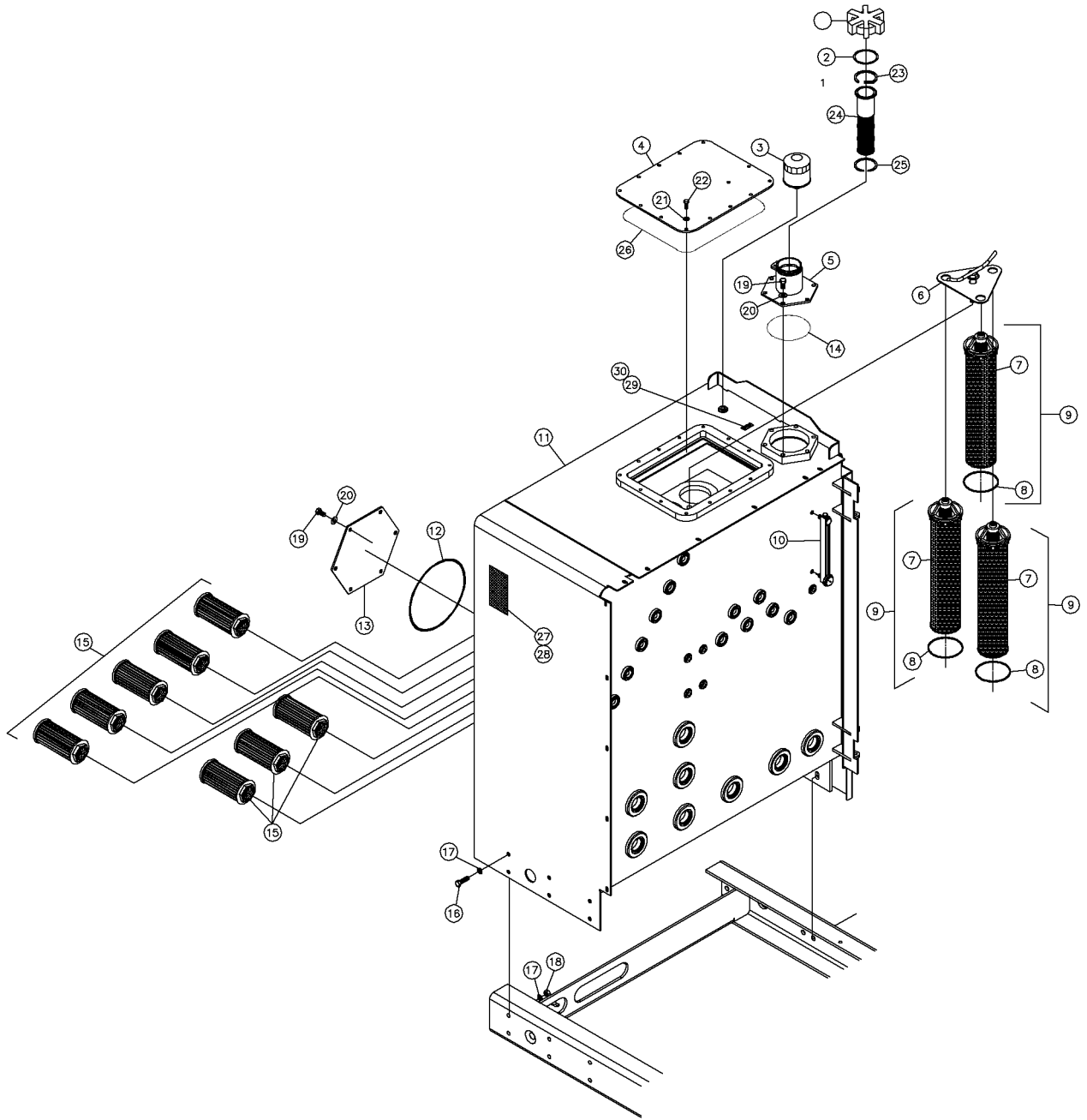

Hyd-Oil Tank Assy Fig 5-30

REF. NO.	*	PART NO.	DESCRIPTION	QTY.	REMARKS
1		106852001	HYDRAULIC CAP	1	
2		111468001	GASKET	1	
3		108475001	FILTER-BREATHER1/2NPTW/ORELIEF	1	
4		288859001	PLATE - FILTER ACCESS	1	
5		288866001	FILTER /CLEANOUT SUBWELD	1	
6		296256861	LOCK FILETR PLATE	1	
7		609133003	FILTER ELEMENT	3	
8		89671007	SEAL	3	
9		609134001	ASSEMBLY-HYDRAULIC FILTER	3	
10		113092001	GAUGE-10" LIQUID LEVEL	1	
11		288877001	TANK WELDMENT	1	
12		78544001	O-RING AS-378 B46	1	
13		116931001	COVER - CLEANOUT	1	
14		78543001	O-RING AS-357 B46	1	
15		113091001	FILTER-SUMP STRAINER	8	
16		235721001	BOLT-1/2-13X1 1/2 GR8 ZINC PLT	10	
17		485025	WASHER-1/2 FLAT-HARDENED-ZINC	20	
18		235731001	NUT-1/2-13 GR8 ZINC PLTD	10	
19		250539001	BOLT-7/16-14 X 1 GR8 HEX Y/ZI	12	
20		510337609	WASHER-FLATSTD-.44-.50X1.25-.08-YZ	12	
21		235713001	WASHER-3/8 SAE HARD ZINC PLTD	14	
22		235727001	BOLT-3/8-16X1 GR8 HEX ZINC PLT	14	
23		111472001	SNAP RING-INTERNAL	1	
24		111467001	STRAINER-FUEL	1	
25		111471001	SNAP RING-INTERNAL	1	
26		288980001	O-RING-OIL TANK COVER	1	
27		7000A393	DECAL - DANGER	1	
28		700IA393	DECAL - DANGER	1	International
29		2326756	DECAL-HYDRAULIC OIL	1	
30		2326I756	DECAL-HYDRAULIC FLUID	1	International

Hyd-Hose Carrier Assy Fig 5-31r01

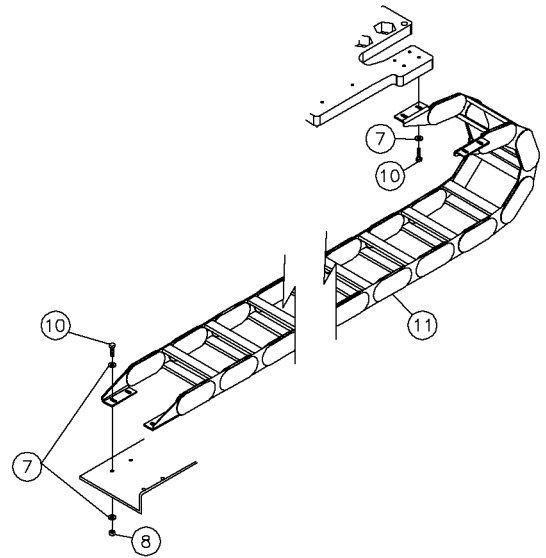
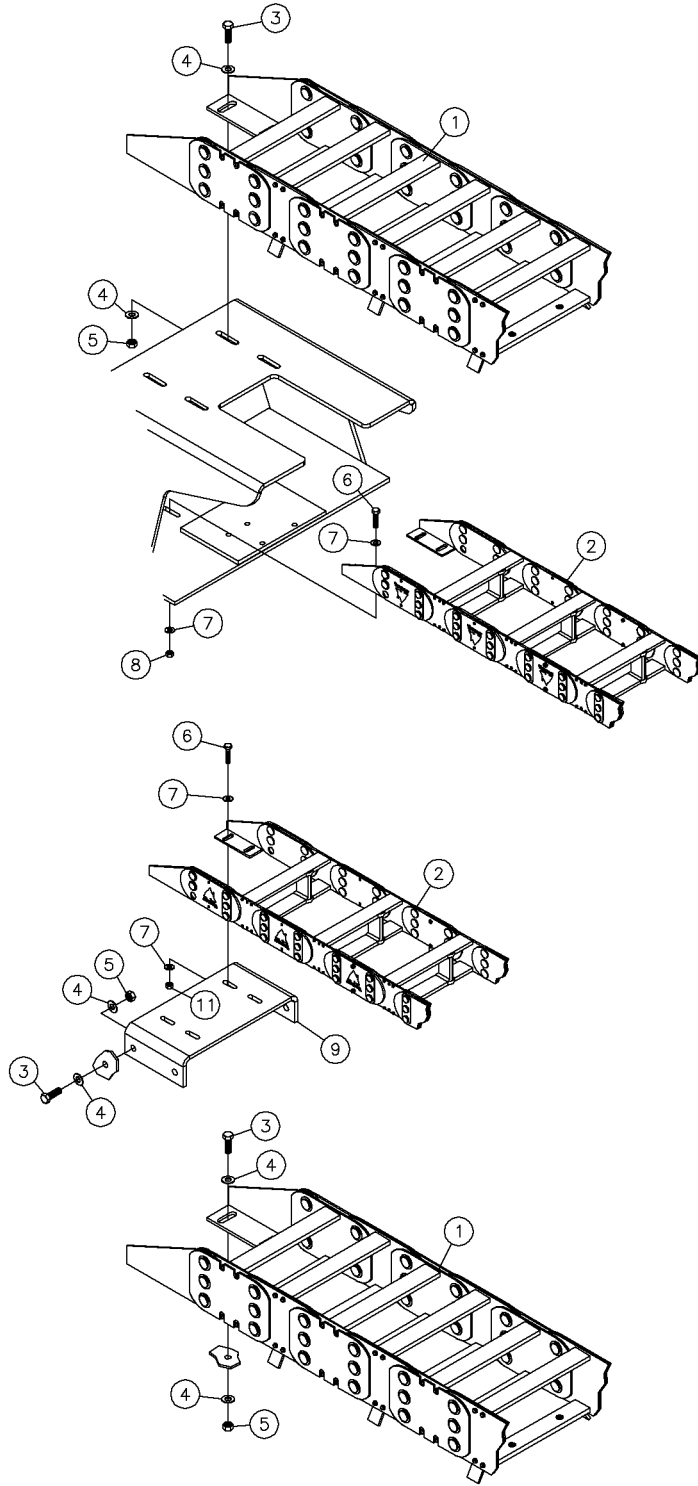

Hyd-Hose Carrier Assy Fig 5-31r01

REF. NO.	*	PART NO.	DESCRIPTION	QTY.	REMARKS
		Revision Date	June, 2002		Update In Illustration & Parts List.
1		277854001	HOSE CARRIER -- PT60E 63 PITCHES	1	Breakdown Fig 12-31
2		277855001	HOSE CARRIER - PT48E - 57 PITCHES	1	Breakdown Fig 12-32
3		235721001	BOLT-1/2-13X1 1/2 GR8 ZINC PLT	12	
4		485025	WASHER-1/2 FLAT-HARDENED-ZINC	24	
5		235731001	NUT-1/2-13 GR8 ZINC PLTD	12	
6		235723001	BOLT-3/8-16X1 1/2 GR8 ZINC PLT	8	
7		235713001	WASHER-3/8 SAE HARD ZINC PLTD	24	
8		235725001	NUT-3/8-16 GR8 ZINC PLTD	12	
9		292840001	PLATE - HOSE CARRIER MOUNT	1	
10		235727001	BOLT-3/8-16X1 GR8 HEX ZINC PLT	8	
11	*	296265382	HOSE CARRIER-PT35E-19 PITCHES	1	Breakdown Fig 12-30r01

Hyd-Hose Carrier Assy Fig 5-31

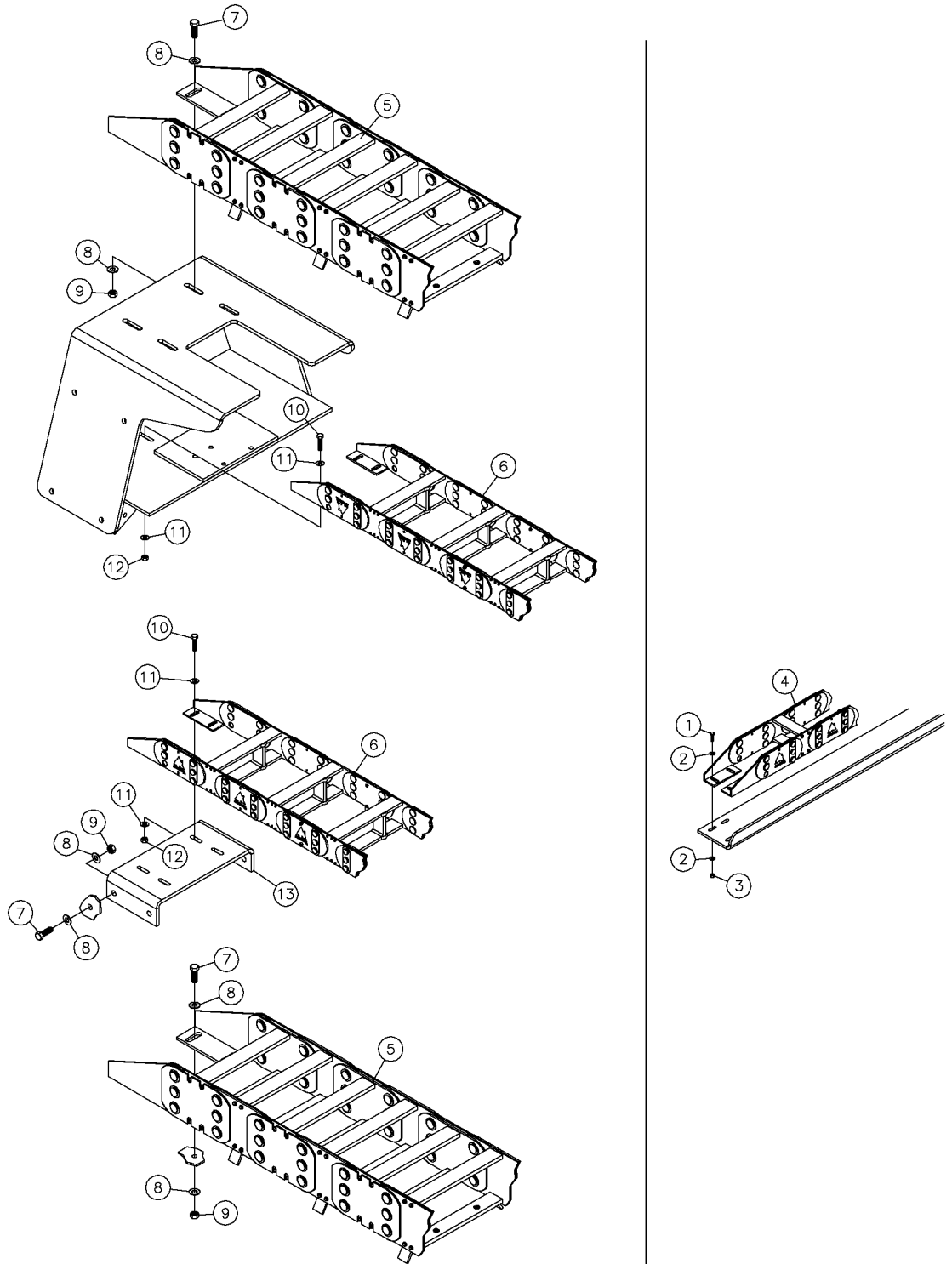

Hyd-Hose Carrier Assy Fig 5-31

REF. NO.	*	PART NO.	DESCRIPTION	QTY.	REMARKS
1		235734001	BOLT-1/4-20X3/4 GR8 ZINC PLTD	8	
2		235716001	WASHER-1/4 SAE HARD ZINC PLTD	16	
3		235732001	NUT-1/4-20 GR8 ZINC PLTD	8	
4		277880001	HOSE CARRIER - PT28E - 95 PITCHES	1	Breakdown Fig 12-30
5		277854001	HOSE CARRIER -- PT60E 63 PITCHES	1	Breakdown Fig 12-31
6		277855001	HOSE CARRIER - PT48E - 57 PITCHES	1	Breakdown Fig 12-32
7		235721001	BOLT-1/2-13X1 1/2 GR8 ZINC PLT	12	
8		485025	WASHER-1/2 FLAT-HARDENED-ZINC	24	
9		235731001	NUT-1/2-13 GR8 ZINC PLTD	12	
10		235723001	BOLT-3/8-16X1 1/2 GR8 ZINC PLT	8	
11		235713001	WASHER-3/8 SAE HARD ZINC PLTD	16	
12		235725001	NUT-3/8-16 GR8 ZINC PLTD	8	
13		292840001	PLATE - HOSE CARRIER MOUNT	1	

Hyd-Main Frame Manifold Fig 5-32

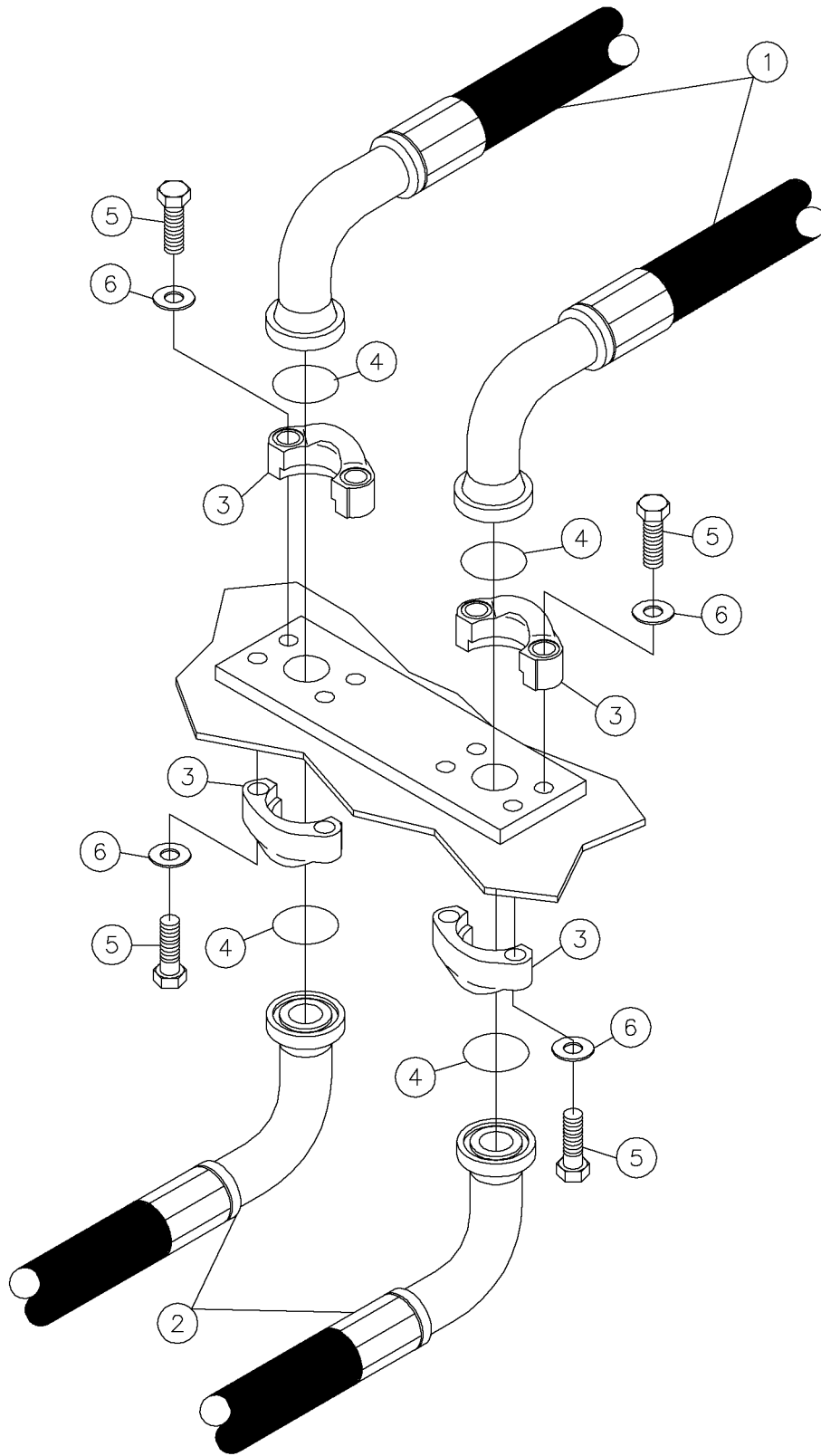

Hyd-Main Frame Manifold Fig 5-32

REF. NO.	*	PART NO.	DESCRIPTION	QTY.	REMARKS
1		296258398	HOSE - 1.50 X 445 24C62 90/ST G6K	2	
2		296256876	HOSE - 1.50 X 93 24C62 45/30 G6K	2	
3		606170001	FLANGE - CODE 61 #24 SPLIT PR	8	
4		72897001	O RING-SQ. #24 FLANGE	4	
5		145645001	BOLT - 5/8 - 11 X 2 GR.8 PLATED	16	
6		235715001	WASHER-5/8 SAE HARD ZINC PLTD	16	

Miscellaneous Fig 5-33

CORDURA SLEEVES



INSIDE DIAMETER	PART NUMBER
.71	83726-001
.90	235824-001
1.22	66094-001
1.42	67264-001
1.59	69129-001
1.81	53840-001
2.37	53841-001

NOTE: SPECIFY LENGTH WHEN ORDERING

TIE STRAPS



LENGTH	PART NUMBER
4 IN.	78657-001
6 IN.	18355-001
8 IN.	59634-001
15 IN.	58151-001

O-RINGS

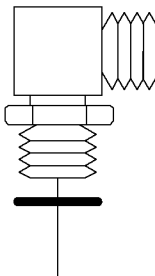

SAE FITTING SIZE	REPLACEMENT O-RING PART NO.
4M	78185-027
5M	53649-081
6M	59088-057
8M	59088-053
10M	792-029
12M	3152-013
14M	3155-015
16M	81580-001
20M	93316-001

NOTE: O-RINGS LISTED ARE 90 DURAMETER

Miscellaneous Fig 5-33

REF. NO.	*	PART NO.	DESCRIPTION	QTY.	REMARKS
		Revision Date	June, 2002		Addition To Manual

Hyd-Cold Start Vavle Assy Fig 5-34

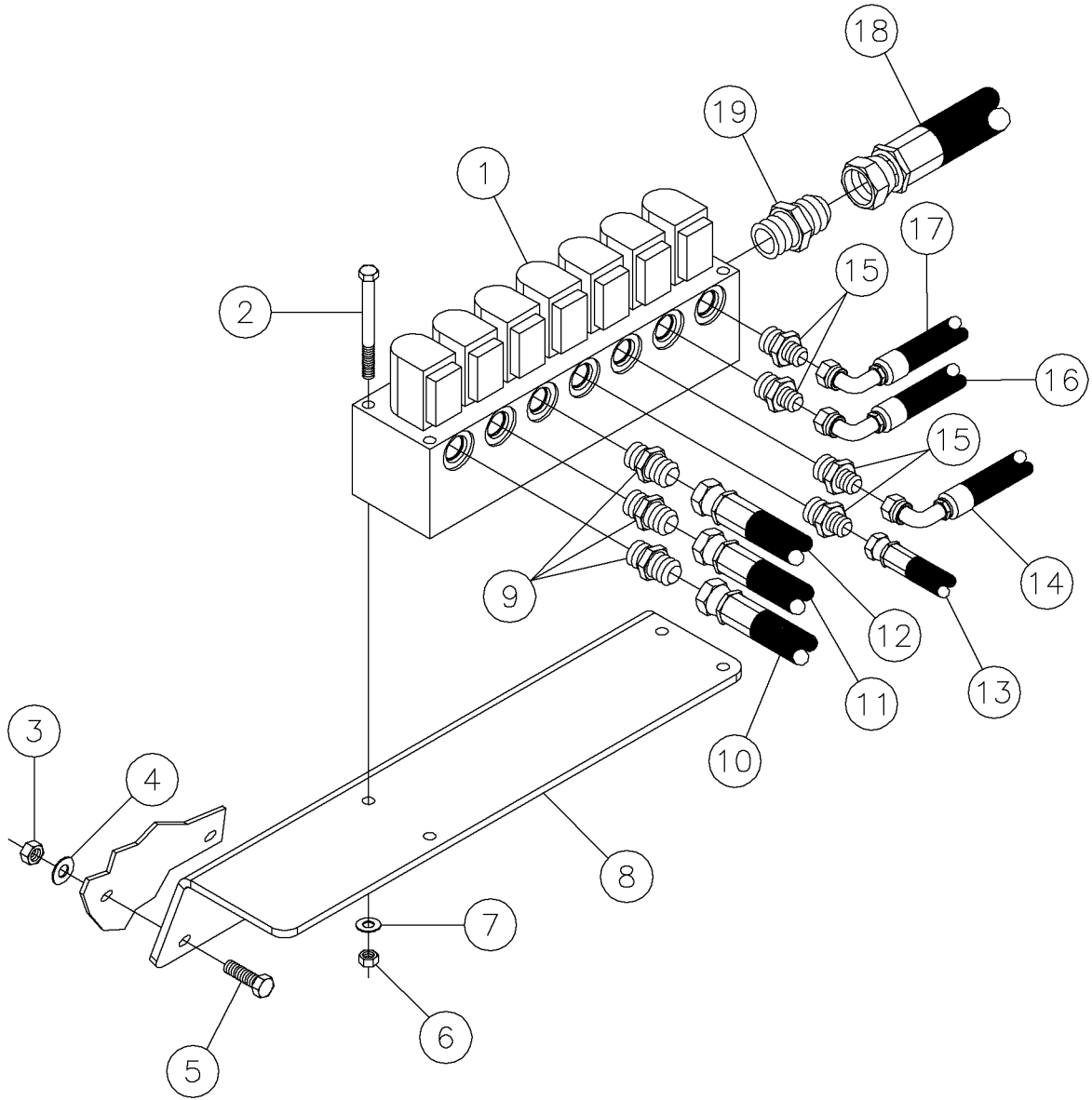

Hyd-Cold Start Vavle Assy Fig 5-34

REF. NO.	*	PART NO.	DESCRIPTION	QTY.	REMARKS
		Revision Date	October, 2004		Addition To Manual
1		296267885	VALVE-COLD START BYPASS	1	
		296278020	SOLENOID VALVE	7	
		296278021	COIL - 24VDC	7	
		260609019	SEAL KIT	7	
		296278022	JAM NUT	7	
2		250503001	BOLT 5/16 - 18 X 3 3/4 Gr8 HEX	4	
3		235725001	NUT - HEX - .38 - 16 - GR8 - YZ	2	
4		235713001	WASHER - FLATSTRL - .38 - .41 X .81 - .06-YA-A325	2	
5		235736001	BOLT-3/8-16X1 1/4 ZINC PLTD	2	
6		235741001	NUT - HEX - .31 - 18 - GR8 -YZ	4	
7		235714001	WASHER - FLATSTRL - .31 - .34 X .69 - .06-YZ-A325	4	
8		296267958	MOUNT - COLD START VALVE	1	
9		53824001	FITTING-#8M O-RING-#8M JIC ST.	3	
10		296266459	HOSE-0.5X16 8FJ ST/45 3000PSI 8M3K	1	
11		296069001	HOSE-HYD-.50 X 18.0 8FSJ ST/45 3000PSI	1	
12		53844425	HOSE-1/2X22 8FSJIC-8FSJIC 45	1	
13		296266460	HOSE-0.375X15 6FJ 90/90-180 3000PSI 6M3K	1	
14		148975001	HOSE - 3/8 X 19 6FSJIC ST/90 3000#	1	
15		60247001	FITTING - 8M O-RING X 6M JIC ST.	4	
16		278800001	HOSE-3/8X23 6FSJIC ST/90 M3K	1	
17		296256871	HOSE - .375 X 26 6FS JIC ST/90 M3K	1	
18		53845439	HOSE-3/4X32 12FS JIC 3000 PSI	1	
19		59434001	12M JICX12M LONG ST THRD ADPT	1	

Cab/Mainframe Mounting Assy Fig 6-1r01

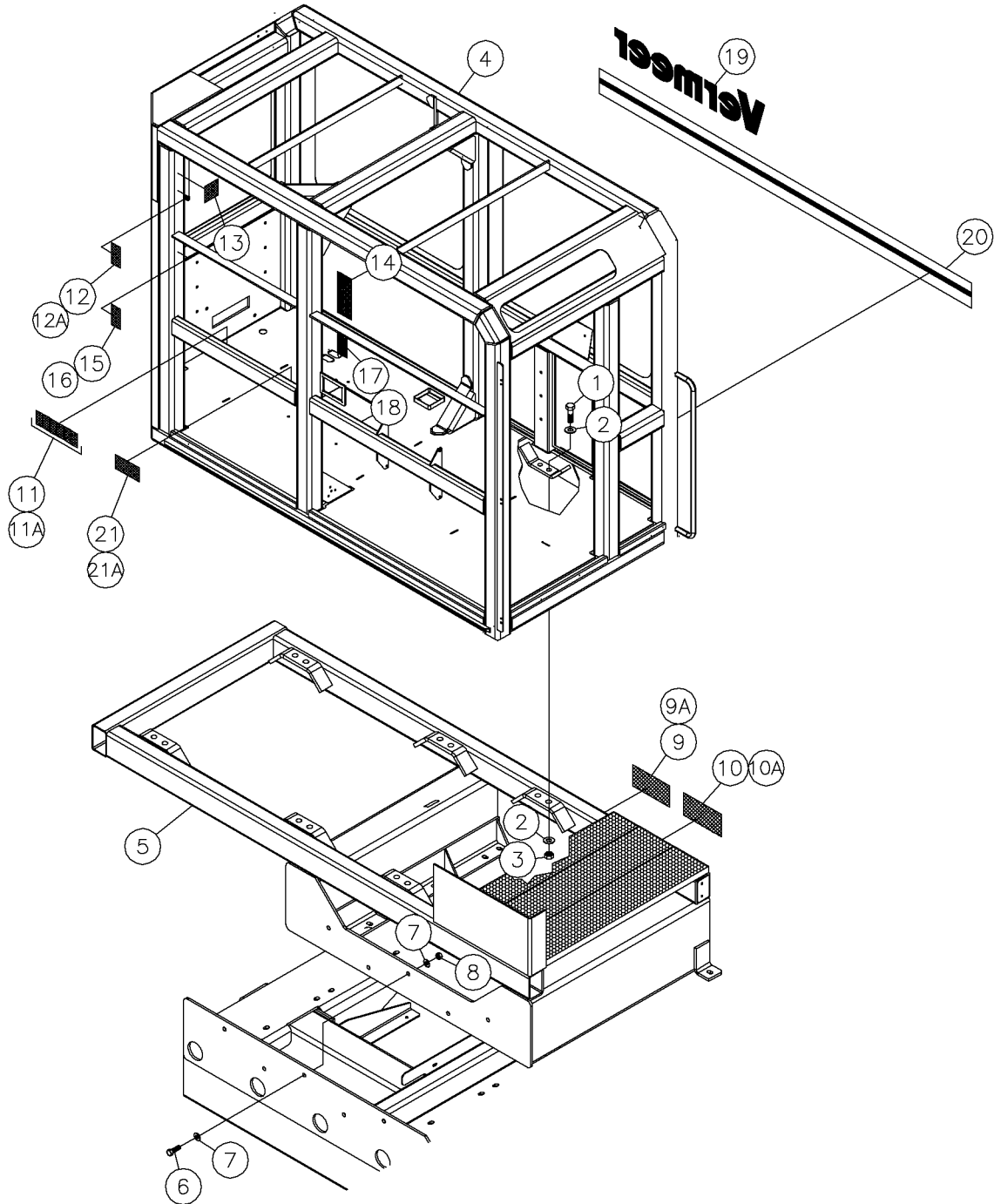

Cab/Mainframe Mounting Assy Fig 6-1r01

REF. NO.	*	PART NO.	DESCRIPTION	QTY.	REMARKS
		Revision Date	June, 2002		Change Cab And Number
1		238887001	BOLT-1-8 X 3 HHCS GR8 ZY	12	
2		238892001	WASHER-1" HARDENED FLAT ZY	24	
3		238215001	NUT 1-8 GR8 ZINC YC	12	
4	*	296257366	WELDMENT - CAB D150X300	1	
5		296256299	EXTENSION - MAINFRAME	1	
6		238880001	BOLT-3/4-10X2 1/2 HHCS GR8 ZY	22	
7		235717001	WASHER-3/4 FLAT HARDENED YELLOW ZINC	44	
8		235739001	NUT-3/4-10 GR8 ZINC PLTD	22	
9		7000B623	DECAL - DANGER ELECTRIC SHOCK	1	
9A		700IB623	DECAL - DANGER ELECTRIC SHOCK	1	International
10		7000B617	DECAL - DANGER POWER LINES	1	
10A		700IB617	DECAL - DANGER POWER LINES	1	International
11		7000B621	DECAL - WARNING LAUNDRY LIST	1	
11A		700IB621	DECAL - WARNING LAUNDRY LIST	1	International
12		7000A971	DECAL - DANGER	1	
12A		700IA971	DECAL-DANGER	1	International
13		7000B119	DECAL - PATENT INDUSTRIAL	1	
14		7000B712	DECAL - DANGER	1	
15		7000B711	DECAL - WARNING - FALLING LOAD	1	
16		700IB711	DECAL - WARNING - FALLING LOAD	1	
17		7000B667	DECAL - DANGER	1	
18		700IB667	DECAL - DANGER	1	International
19		70000803	DECAL-VERMEER 8 1/2	1	
20		70000777	DECAL 6"VERMEER STRIPE	A/R	P/N Qty Of 1 = 1 Foot
21		7000B624	DECAL - DANGER KEEP AWAY	1	
21A		700IB624	DECAL - DANGER KEEP AWAY	1	International

Cab/Mainframe Mounting Assy Fig 6-1

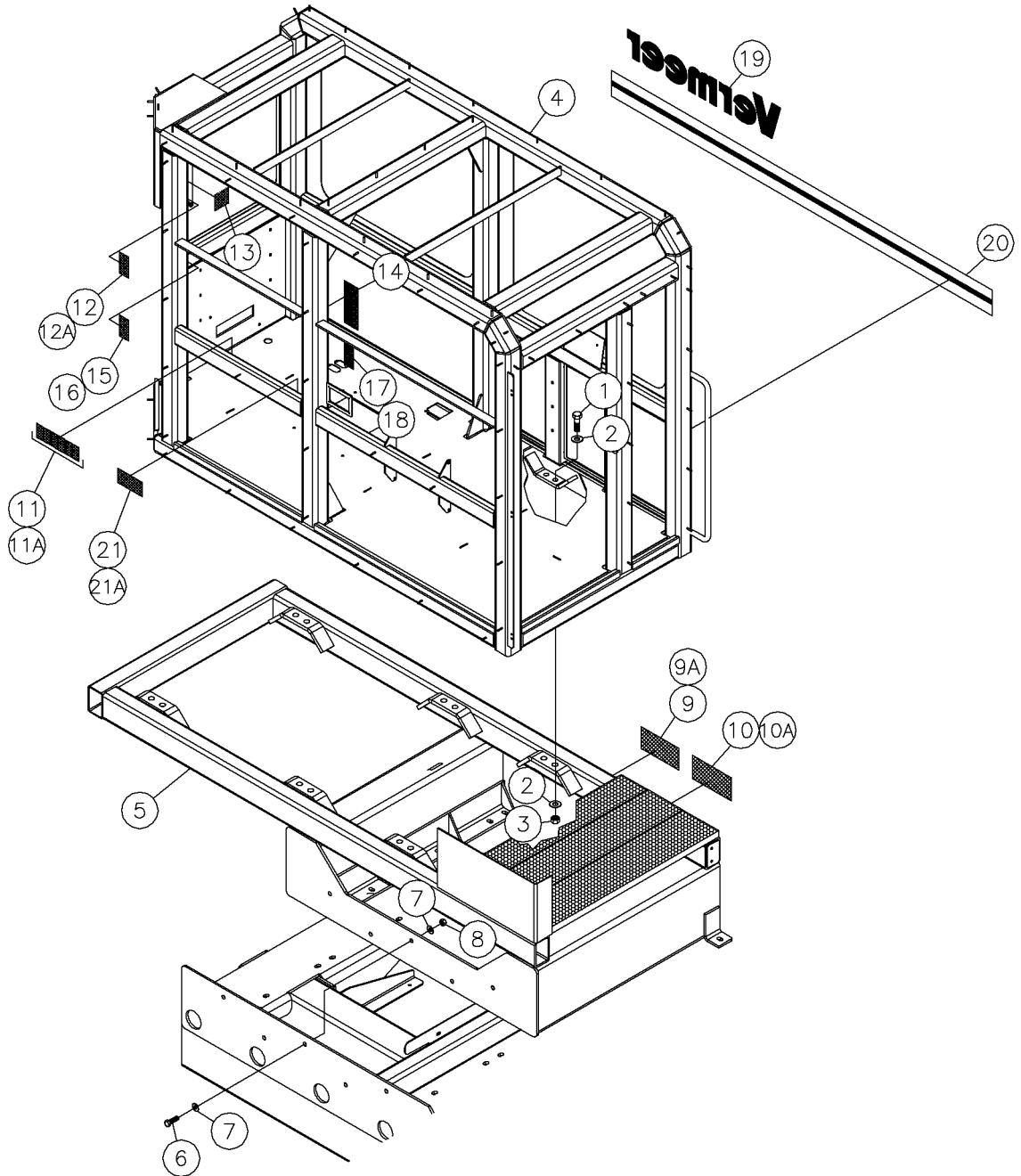

Cab/Mainframe Mounting Assy Fig 6-1

REF. NO.	*	PART NO.	DESCRIPTION	QTY.	REMARKS
1		238887001	BOLT-1-8 X 3 HHCS GR8 ZY	12	
2		238892001	WASHER-1" HARDENED FLAT ZY	24	
3		238215001	NUT 1-8 GR8 ZINC YC	12	
4		293659001	WELDMENT - CAB D150X300	1	
5		296256299	EXTENSION - MAINFRAME	1	
6		238880001	BOLT-3/4-10X2 1/2 HHCS GR8 ZY	22	
7		235717001	WASHER-3/4 FLAT HARDENED YELLOW ZINC	44	
8		235739001	NUT-3/4-10 GR8 ZINC PLTD	22	
9		7000B623	DECAL - DANGER ELECTRIC SHOCK	1	
9A		700IB623	DECAL - DANGER ELECTRIC SHOCK	1	International
10		7000B617	DECAL - DANGER POWER LINES	1	
10A		700IB617	DECAL - DANGER POWER LINES	1	International
11		7000B621	DECAL - WARNING LAUNDRY LIST	1	
11A		700IB621	DECAL - WARNING LAUNDRY LIST	1	International
12		7000A971	DECAL - DANGER	1	
12A		700IA971	DECAL-DANGER	1	International
13		7000B119	DECAL - PATENT INDUSTRIAL	1	
14		7000B712	DECAL - DANGER	1	
15		7000B711	DECAL - WARNING - FALLING LOAD	1	
16		700IB711	DECAL - WARNING - FALLING LOAD	1	
17		7000B667	DECAL - DANGER	1	
18		700IB667	DECAL - DANGER	1	International
19		70000803	DECAL-VERMEER 8 1/2	1	
20		70000777	DECAL 6"VERMEER STRIPE	A/R	P/N Qty Of 1 = 1 Foot
21		7000B624	DECAL - DANGER KEEP AWAY	1	
21A		700IB624	DECAL - DANGER KEEP AWAY	1	International

Cab-Foam Assy Fig 6-2r01

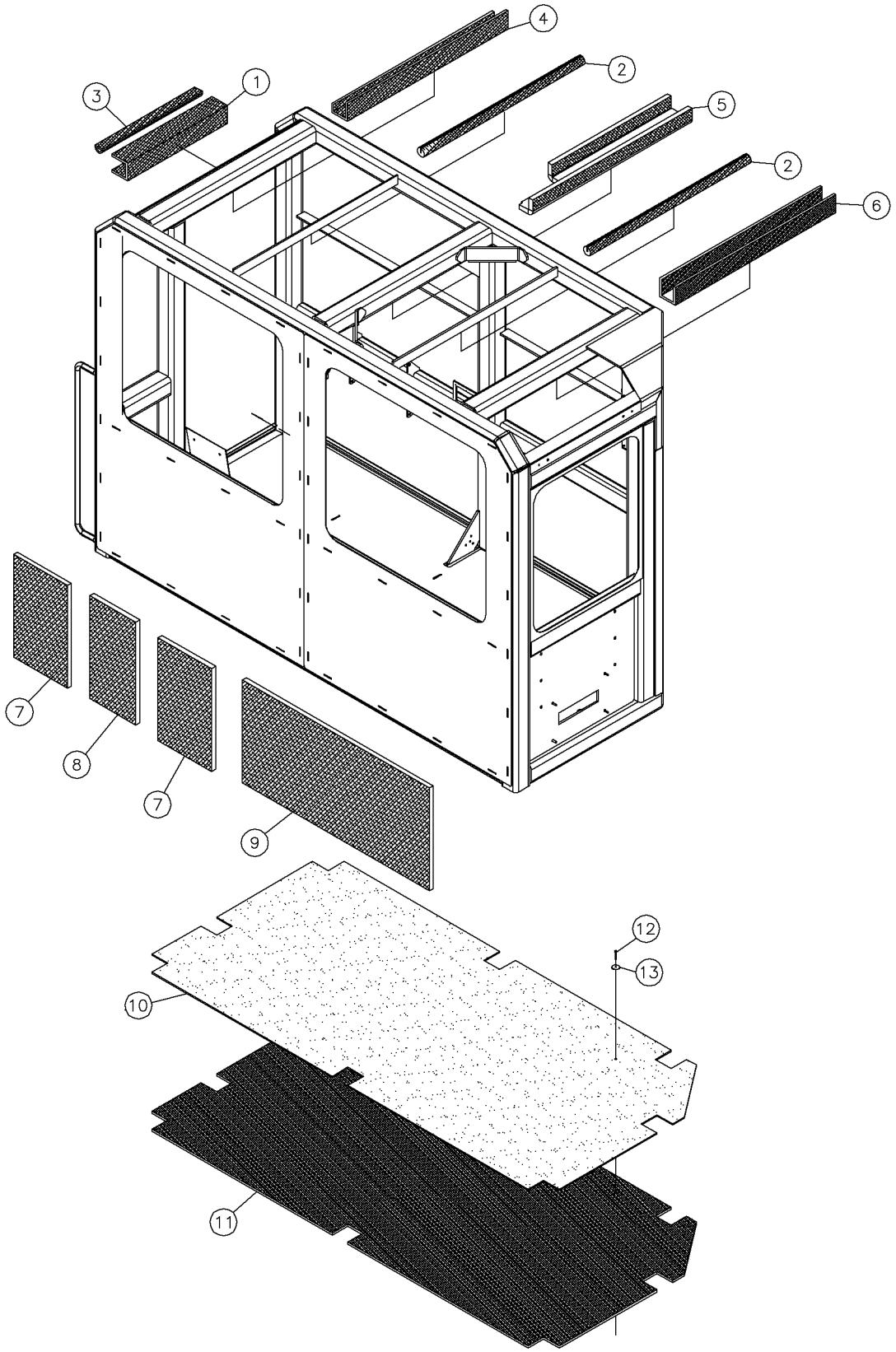

Cab-Foam Assy Fig 6-2r01

REF. NO.	*	PART NO.	DESCRIPTION	QTY.	REMARKS
		Revision Date	June, 2002		Updated Drawing
1		296262518	FOAM - CAB HEADER	1	
2		296256456	INSULATION - .375 X .75 X .72 PIPE INSULATION	A/R	P/N Qty Of 1 = 1 Each
3		288982001	SEAL - 1" X 1" HALF ROUND	A/R	P/N Qty Of 1 = 1 Each
4		296262519	FOAM - CAB HEADER	1	
5		296262521	FOAM - CAB HEADER	1	
6		296262520	FOAM - CAB HEADER	1	
7		296262515	FOAM - CAB SIDE	2	
8		296262516	FOAM - SIDE	1	
9		296262517	FOAM - CAB SIDE	1	
10		296262578	CAB - FLOOR LAMINATE	1	
11		296262577	CAB - FLOOR FOAM	1	
12		296257376	1/4 - 14 X 1 1/4 HWH DRILL SCREW	25	
13		296257377	WASHER - FENDER - .25 X 1.25-16 GA.CZ	25	

Cab-Foam Assy Fig 6-2

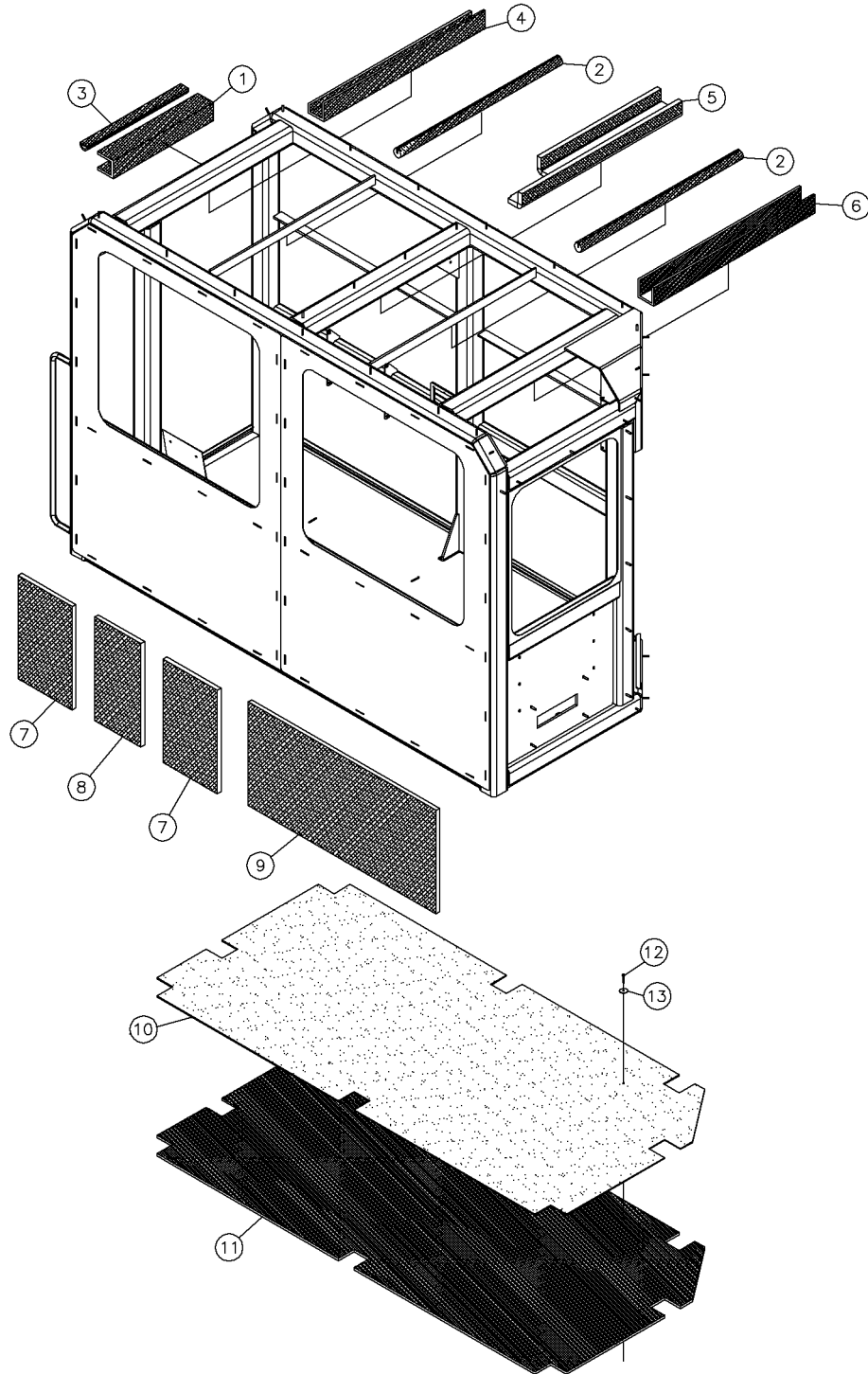

Cab-Foam Assy Fig 6-2

REF. NO.	*	PART NO.	DESCRIPTION	QTY.	REMARKS
1		296262518	FOAM - CAB HEADER	1	
2		296256456	INSULATION - .375 X .75 X .72 PIPE INSULATION	A/R	P/N Qty Of 1 = 1 Each
3		288982001	SEAL - 1" X 1" HALF ROUND	A/R	P/N Qty Of 1 = 1 Each
4		296262519	FOAM - CAB HEADER	1	
5		296262521	FOAM - CAB HEADER	1	
6		296262520	FOAM - CAB HEADER	1	
7		296262515	FOAM - CAB SIDE	2	
8		296262516	FOAM - SIDE	1	
9		296262517	FOAM - CAB SIDE	1	
10		296262578	CAB - FLOOR LAMINATE	1	
11		296262577	CAB - FLOOR FOAM	1	
12		296257376	1/4 - 14 X 1 1/4 HWH DRILL SCREW	25	
13		296257377	WASHER - FENDER - .25 X 1.25-16 GA.CZ	25	

Cab Window Assy Fig 6-3r03

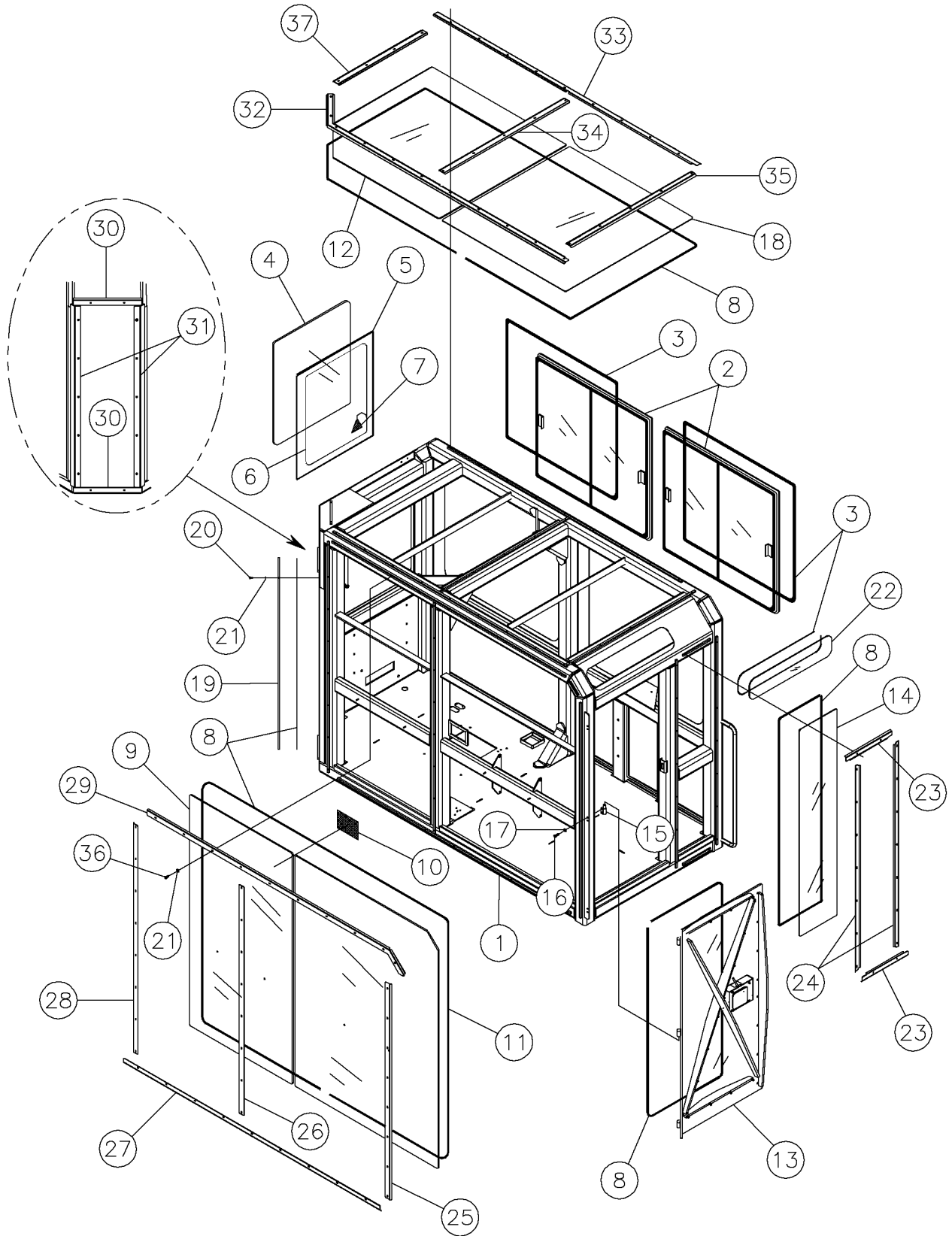

Cab Window Assy Fig 6-3r03

REF. NO.	*	PART NO.	DESCRIPTION	QTY.	REMARKS
		Revision Date	October, 2004		Update In Illustration & Parts List.
1		296257366	WELDMENT - CAB	1	
2		296256373	WINDOW - SLIDING GLASS	2	
3		111849001	WEATHERSTRIP-AS-1660	A/R	P/N Qty Of 1 = 1 Foot
4		296262536	WINDOW - FRONT	1	
5		296262564	SEAL - EMERGENCY EXIT	A/R	P/N Qty Of 1 = 1 Foot
6		296262565	SEAL - EMERGENCY EXIT LOCK	A/R	P/N Qty Of 1 = 1 Foot
7		613376001	TAG - EMERGENCY EXIT	1	
8		18991001	WEATHERSTRIP-5/16X3/4 SELFSTK	A/R	P/N Qty Of 1 = 1 Foot
9		296257391	WINDOW - LEFT CENTER CAB	1	
10		296264801	DECAL - CAPACITY CHART 7.5 X 5.5	1	
11		296257390	WINDOW - LEFT REAR	1	
12		296266380	WINDOW -TOP FRONT CAB	1	
13		296256435	ASSEMBLY - CAB DOOR	1	Breakdown On Fig 6-4
14		296266385	WINDOW - RIGHT REAR CAB	3	
15		224782001	HINGE-NYLON LIFT OFF 1/4" THD	6	
16		235735001	BOLT-1/4-20X1 GR8 HEX ZNC PLTD	6	
17		235716001	WASHER - FLATSTRL - .25 -.28 X .63 - .06 - CZ	1	
18		296266381	WINDOW - TOP REAR CAB	1	
19		296266379	WINDOW - LEFT FRONT CAB	1	
20		296275503	SCREW - SBHCS .25 - 20 X 0.75 GR8, CZ	18	
21		296257377	WASHER - FENDER - .25 X 1.25-16 GA.CZ	114	
22		296103001	WINDOW - CAB	1	
23		296266384	CLIP - REAR WINDOW	2	
24		296266386	CLIP - REAR WINDOW	2	
25		296266361	CLIP - WINDOW UPRIGHT (SHORT)	1	
26		296266362	CLIP - WINDOW CENTER	1	
27		296266360	CLIP - WINDOW BOTTOM	1	
28		296266359	CLIP - WINDOW UPRIGHT	1	
29		296266358	CLIP - WINDOW TOP	1	
30		296266454	CLIP - CORNER WINDOW, ENDS	2	
31		296266453	CLIP - WINDOW, CORNER	2	
32		296266366	CLIP - TOP WINDOW, LEFT	1	
33		296266367	CLIP - WINDOW, RIGHT	1	
34		296266389	CLIP - WINDOW, CENTER	1	
35		296266368	CLIP - WINDOW - REAR	1	
36		296273795	SCREW - SBHCS .25-20 X 0.50 GR8, CZ	96	
37		296275542	CLIP - WINDOW - TOP	1	

Cab Window Assy Fig 6-3r02

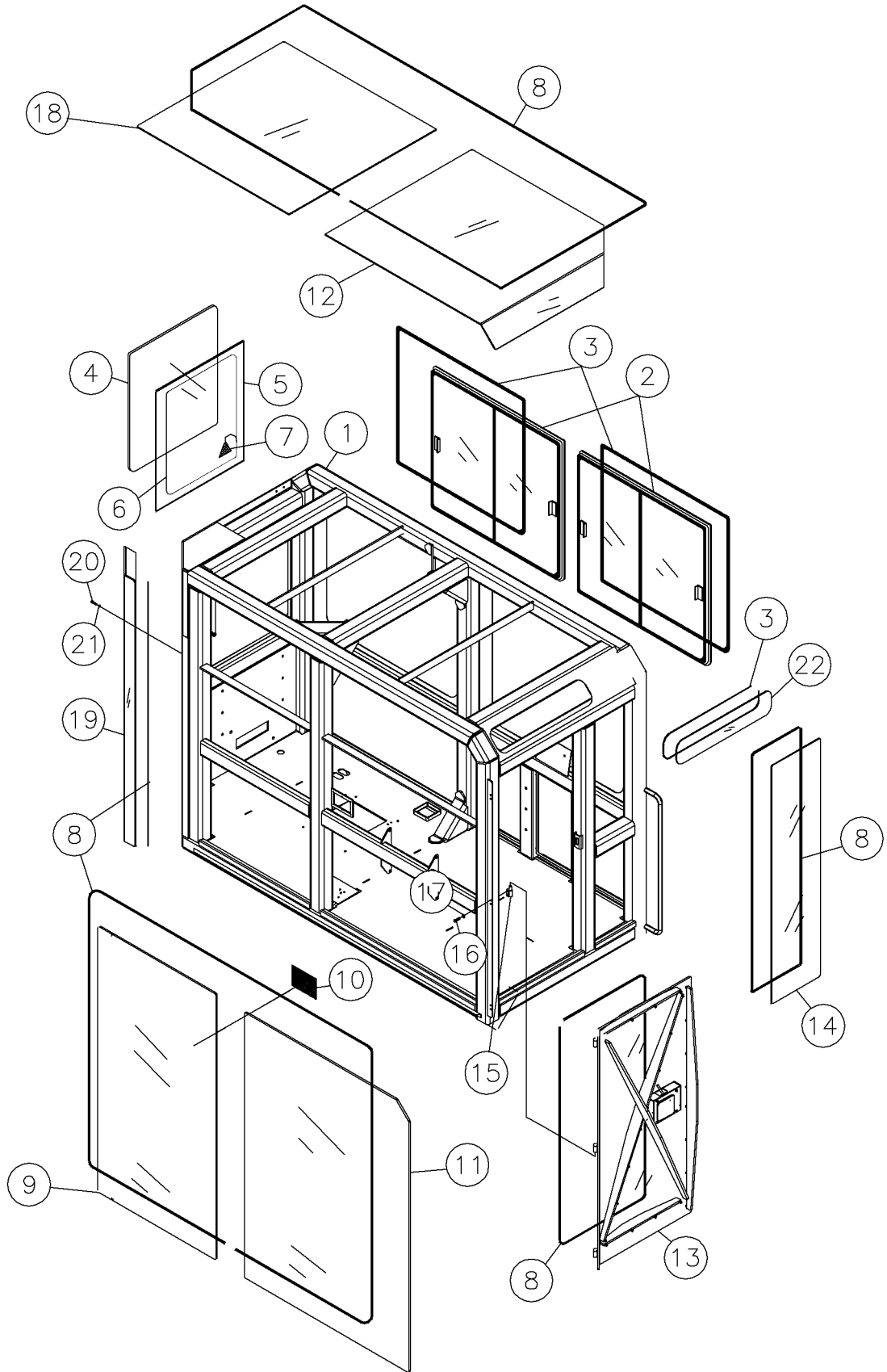

Cab Window Assy Fig 6-3r02

REF. NO.	*	PART NO.	DESCRIPTION	QTY.	REMARKS
		Revision Date	June, 2002		Update In Illustration & Parts List.
1		293659001	WELDMENT - CAB D150X300	1	
2		296256373	WINDOW - SLIDING GLASS	2	
3		111849001	WEATHERSTRIP-AS-1660	A/R	P/N Qty Of 1 = 1 Foot
4		296262536	WINDOW - FRONT	1	
5		296262564	SEAL - EMERGENCY EXIT	A/R	P/N Qty Of 1 = 1 Foot
6		296262565	SEAL - EMERGENCY EXIT LOCK	A/R	P/N Qty Of 1 = 1 Foot
7		613376001	TAG - EMERGENCY EXIT	1	
8		18991001	WEATHERSTRIP-5/16X3/4 SELFSTK	A/R	P/N Qty Of 1 = 1 Foot
9	*	296257391	WINDOW - LEFT CENTER CAB	1	
10		296264801	DECAL - CAPACITY CHART 7.5 X 5.5	1	
11	*	296257390	WINDOW - LEFT REAR	1	
12	*	296257394	WINDOW - TOP FRONT CAB	1	
13		296256435	ASSEMBLY - CAB DOOR	1	Breakdown On Fig 6-4
14		296256339	WINDOW - RIGHT REAR	1	
15		224782001	HINGE-NYLON LIFT OFF 1/4" THD	3	
16		235735001	BOLT-1/4-20X1 GR8 HEX ZNC PLTD	6	
17		235716001	WASHER-1/4 SAE HARD ZINC PLTD	6	
18	*	296257393	WINDOW - TOP REAR CAB	1	
19	*	296257392	WINDOW - LEFT FRONT CAB	1	
20		296257376	1/4 - 14 X 1 1/4 HWH DRILL SCREW	17	
21		296257377	WASHER - FENDER - .25 X 1.25-16 GA.CZ	17	
22	*	296103001	WINDOW - CAB	1	

Cab Window Assy Fig 6-3r01

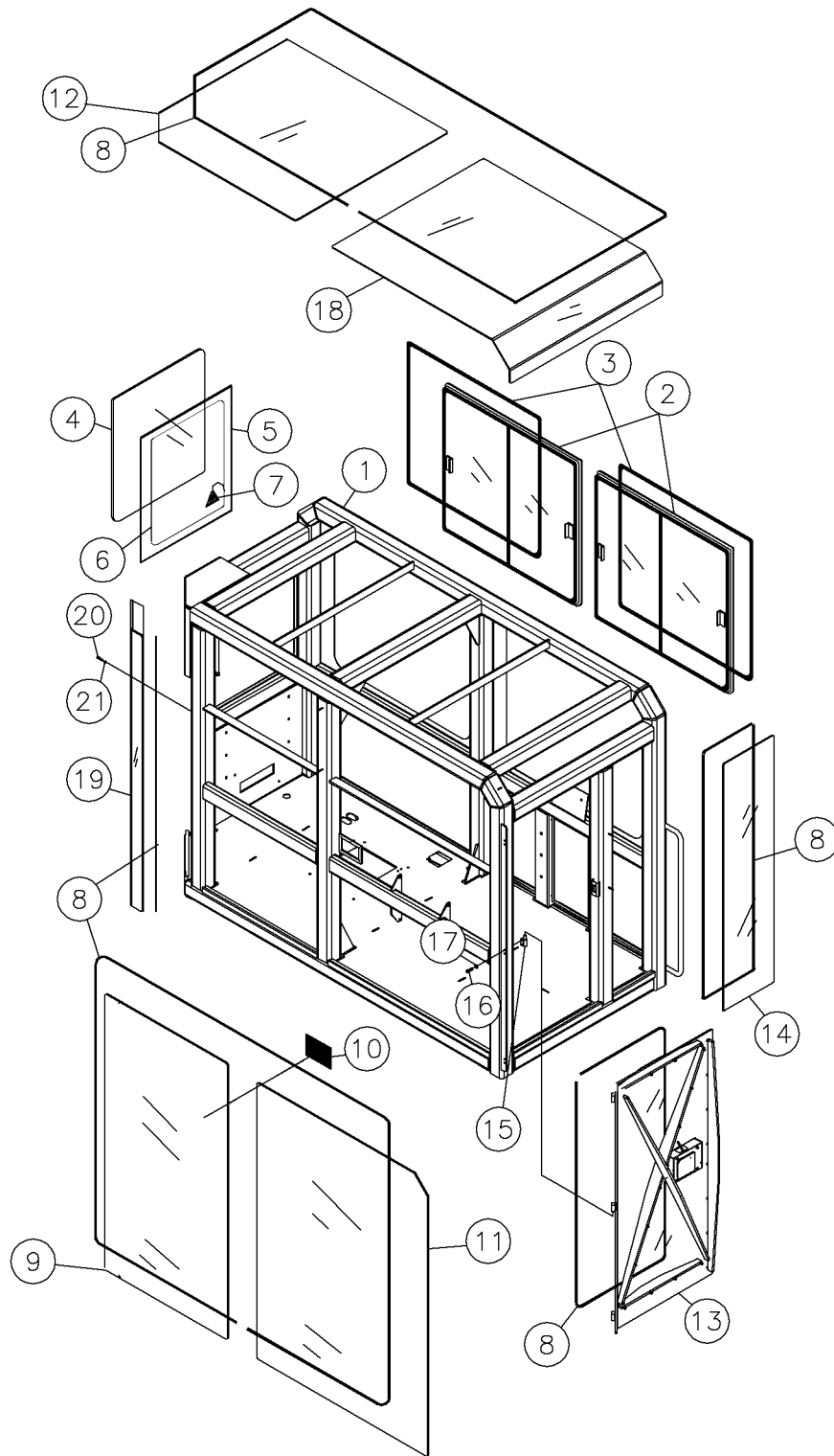

Cab Window Assy Fig 6-3r01

REF. NO.	*	PART NO.	DESCRIPTION	QTY.	REMARKS
1		293659001	WELDMENT - CAB D150X300	1	
2		296256373	WINDOW - SLIDING GLASS	2	
3		111849001	WEATHERSTRIP-AS-1660	A/R	P/N Qty Of 1 = 1 Foot
4		296262536	WINDOW - FRONT	1	
5		296262564	SEAL - EMERGENCY EXIT	A/R	P/N Qty Of 1 = 1 Foot
6		296262565	SEAL - EMERGENCY EXIT LOCK	A/R	P/N Qty Of 1 = 1 Foot
7		613376001	TAG - EMERGENCY EXIT	1	
8		18991001	WEATHERSTRIP-5/16X3/4 SELFSTK	A/R	P/N Qty Of 1 = 1 Foot
9		296256335	WINDOW - LEFT CENTER	1	
10		296264801	DECAL - CAPACITY CHART 7.5 X 5.5	1	
11		296256334	WINDOW - LEFT REAR	1	
12		296256338	WINDOW TOP FRONT	1	
13		296256435	ASSEMBLY - CAB DOOR	1	Breakdown On Fig 6-4
14		296256339	WINDOW - RIGHT REAR	1	
15		224782001	HINGE-NYLON LIFT OFF 1/4" THD	3	
16		235735001	BOLT-1/4-20X1 GR8 HEX ZNC PLTD	6	
17		235716001	WASHER-1/4 SAE HARD ZINC PLTD	6	
18		296256337	WINDOW - TOP REAR	1	
19		296256336	WINDOW - LEFT FRONT	1	
20		296257376	1/4 - 14 X 1 1/4 HWH DRILL SCREW	17	
21		296257377	WASHER - FENDER - .25 X 1.25-16 GA.CZ	17	

Cab Window Assy Fig 6-3

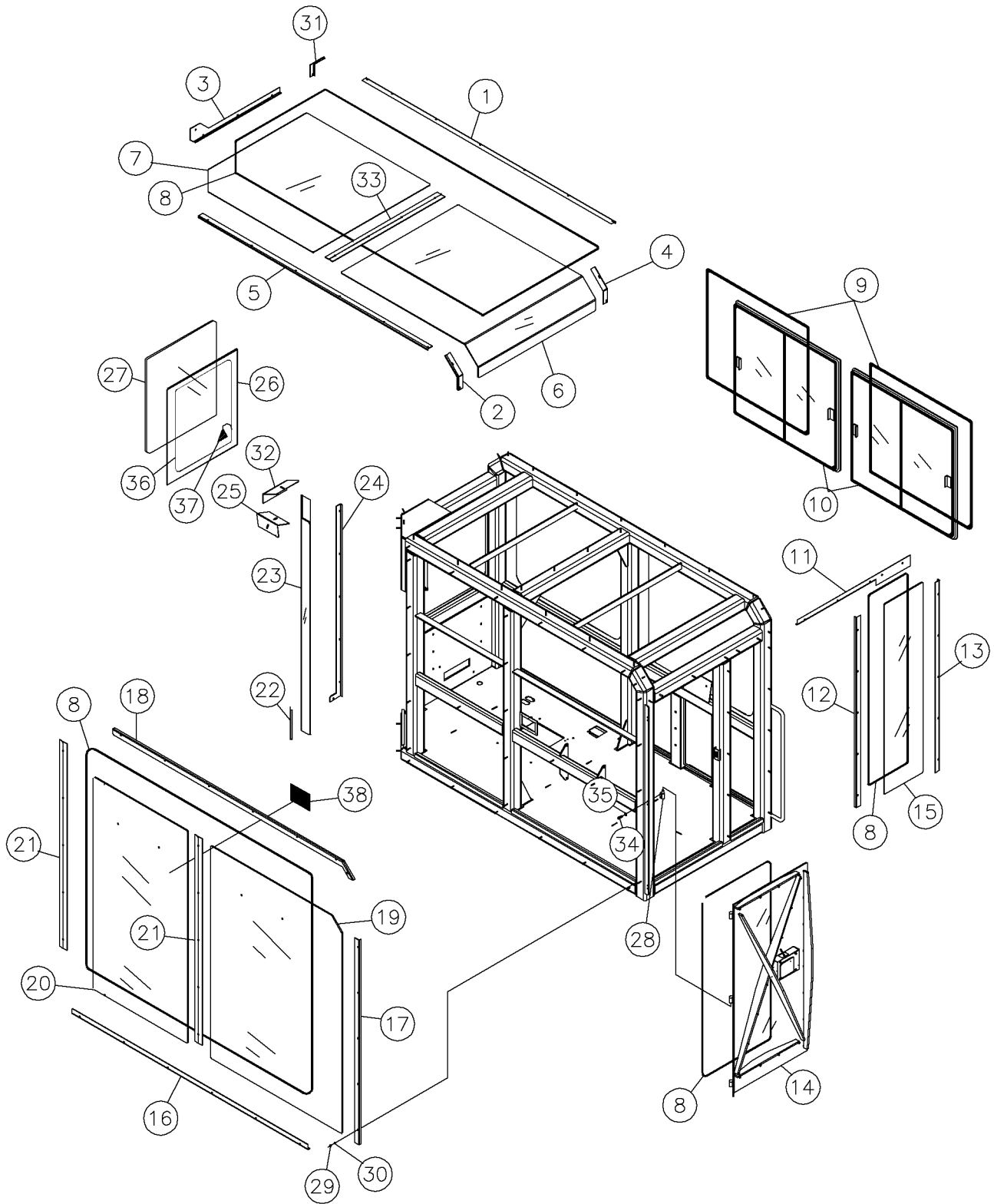

Cab Window Assy Fig 6-3

REF. NO.	*	PART NO.	DESCRIPTION	QTY.	REMARKS
1		296256422	CLAMP - RIGHT TOP GLASS	1	
2		296256421	CLAMP - TOP ANGLED GLASS	2	
3		296256412	CLAMP - TOP FRONT GLASS	1	
4		296256424	CLAMP - TOP ANGLED GLASS	1	
5		296256418	CLAMP - L TOP GLASS	1	
6		296256337	WINDOW - TOP REAR	1	
7		296256338	WINDOW TOP FRONT	1	
8		18991001	WEATHERSTRIP-5/16X3/4 SELFSTK	A/R	P/N Qty Of 1 = 1 Foot
9		111849001	WEATHERSTRIP-5/16X3/4 SELFSTK	A/R	P/N Qty Of 1 = 1 Foot
10		296256373	WINDOW - SLIDING GLASS	2	
11		296256423	CLAMP - HORIZONTAL GLASS	1	
12		296256425	CLAMP - VERTICAL GLASS	1	
13		296256426	CLAMP - VERTICAL GLASS	1	
14		296256435	ASSEMBLY - CAB DOOR	1	Breakdown Fig 6-4
15		296256339	WINDOW - RIGHT REAR	1	
16		296256408	ANGLE - BOTTOM GLASS	1	
17		296256413	CLAMP - VERTICAL GLASS	1	
18		296256414	CLAMP - TOP LEFT GLASS	1	
19		296256334	WINDOW - LEFT REAR	1	
20		296256335	WINDOW - LEFT CENTER	1	
21		296256407	CLAMP - VERTICAL GLASS	2	
22		296256415	CLAMP - LOWER ANGLED GLASS	1	
23		296256336	WINDOW - LEFT FRONT	1	
24		296256411	CLAMP - VERTICAL GLASS	1	
25		296262532	CLAMP - TOP ANGLED GLASS	1	
26		296262564	SEAL - EMERGENCY EXIT	A/R	P/N Qty Of 1 = 1 Foot
27		296262536	WINDOW - FRONT	1	
28		224782001	HINGE-NYLON LIFT OFF 1/4" THD	3	
29		235741001	NUT-5/16-18 GR8 ZINC PLTD	100	
30		235714001	WASHER-5/16 SAE HARD ZINC PLTD	100	
31		296256420	CLAMP - TOP ANGLE GLASS	1	
32		296262533	CLAMP - TOP ANGLED GLASS	1	
33		296256433	CLAMP - TOP GLASS	1	
34		235735001	BOLT-1/4-20X1 GR8 HEX ZNC PLTD	6	
35		235716001	WASHER-1/4 SAE HARD ZINC PLTD	6	
36		296262565	SEAL - EMERGENCY EXIT LOCK	A/R	P/N Qty Of 1 = 1 Foot
37		613376001	TAG - EMERGENCY EXIT	1	
38		296264801	DECAL-CAPACITY CHART 7.5 X 5.5	1	

Cab Door Assy Fig 6-4

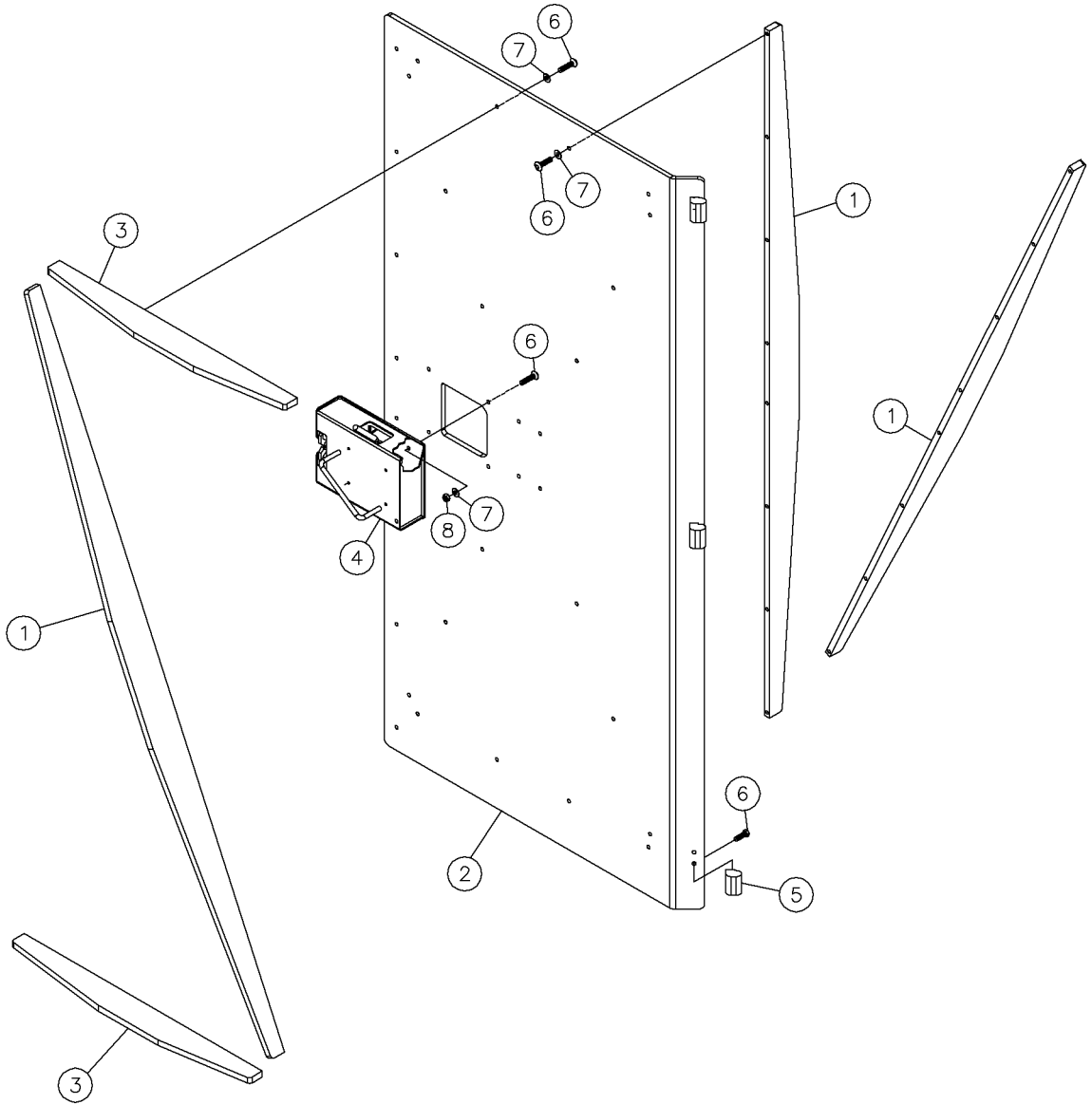

Cab Door Assy Fig 6-4

REF. NO.	*	PART NO.	DESCRIPTION	QTY.	REMARKS
1		296256354	BRACE - VERTICAL DOOR	3	
2		296265340	DOOR	1	
3		296256355	BRACE HORIZONTAL DOOR	2	
4		104024001	LATCH ASSY-R.H. ROTARY	1	Breakdown Fig 6-5
5		224781001	HINGE-NYLON LIFT OFF 1/4" THD	3	
6		296262538	SCREW - SBHCS - .25 -20 X 1.00 - GR8 - CZ	40	
7		235716001	WASHER-1/4 SAE HARD ZINC PLTD	44	
8		235732001	NUT-1/4-20 GR8 ZINC PLTD	4	

Cab-Door Latch Assy Fig 6-5r01

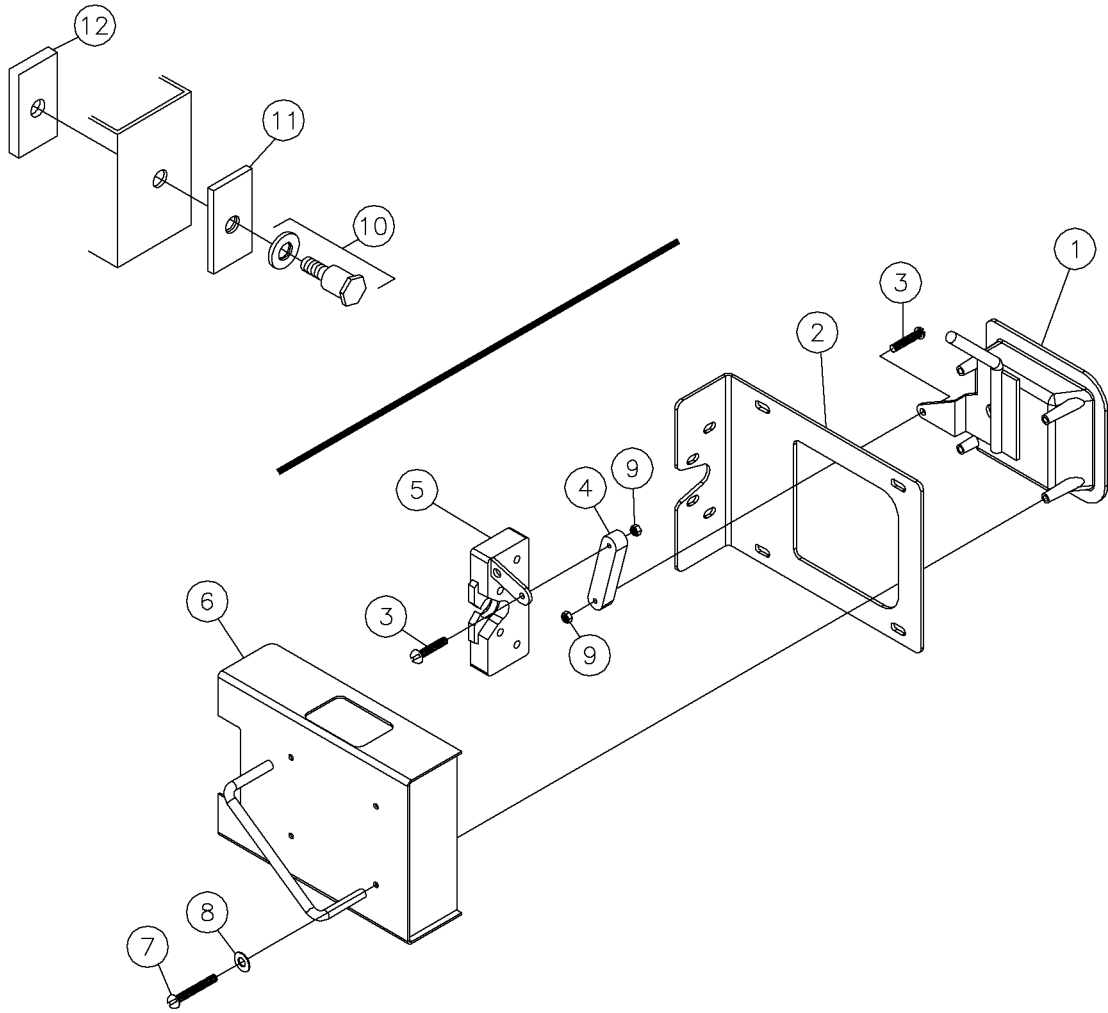

Cab-Door Latch Assy Fig 6-5r01

REF. NO.	*	PART NO.	DESCRIPTION	QTY.	REMARKS
		Revision Date	June, 2002		Change Part Number
1		72365001	R.H. LOCK PADDLE ASSY W/HANDLE	1	
2		296256344	PLATE - DOOR LATCH	1	
3		1802010	BOLT - 3/16" X 1" NC STOVE	2	
4		293731001	LINK - DOOR LATCH	1	
5		104024001	LATCH ASSY-R.H. ROTARY	1	
6		296256431	COVER - DOOR LATCH	1	
7		533003	SCREW 10-24X1-1/2 RND HD SLT	4	
8		485001	WASHER-3/16 FLAT	4	
9		400001	NUT-3/16 NC HEX	2	
10		72364001	STRIKER BOLT W/ WASHER	1	
11	*	293736001	PLATE - FRONT STRIKER BOLT	1	
12		293737001	PLATE - STRIKER BOLT	1	

Cab-Door Latch Assy Fig 6-5

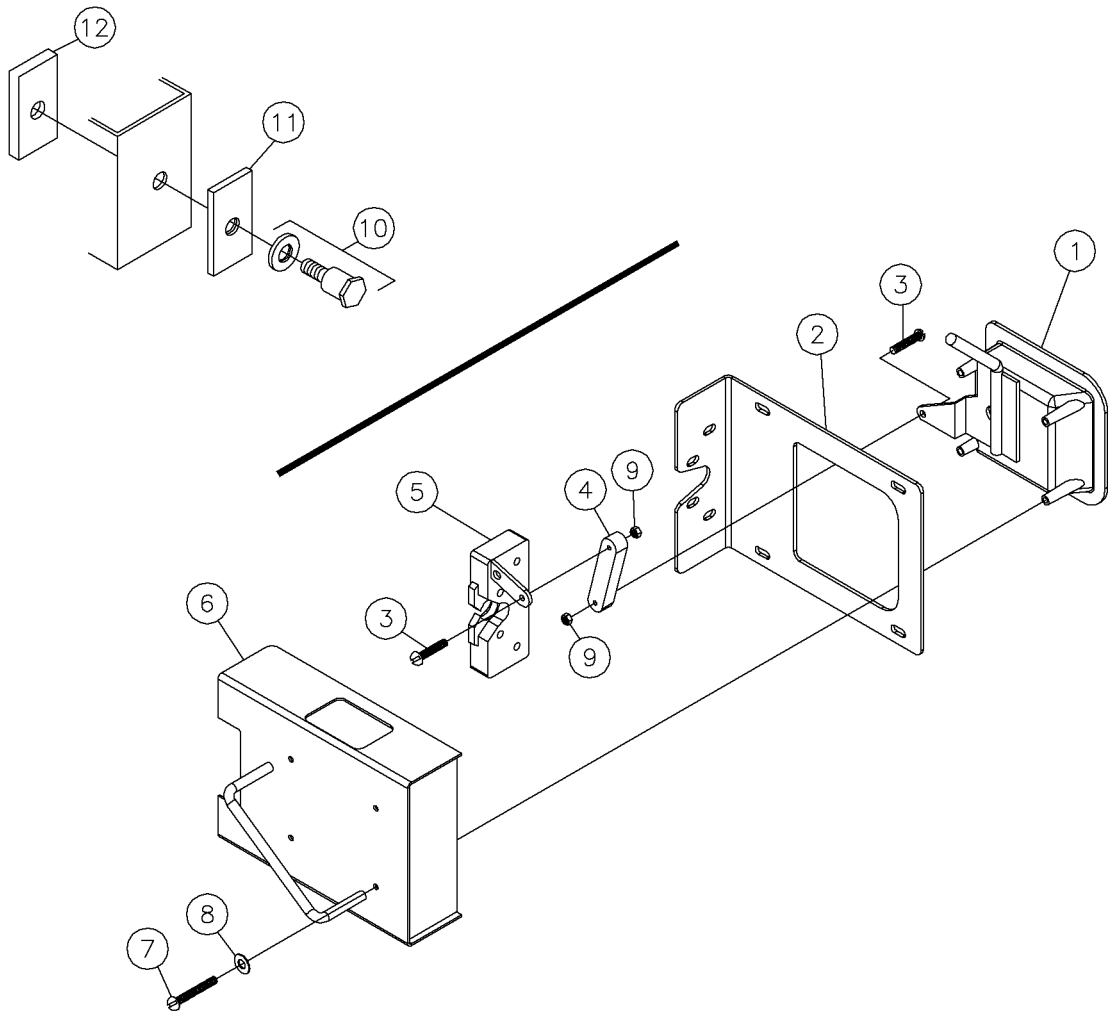

Cab-Door Latch Assy Fig 6-5

REF. NO.	*	PART NO.	DESCRIPTION	QTY.	REMARKS
1		72365001	R.H. LOCK PADDLE ASSY W/HANDLE	1	
2		296256344	PLATE - DOOR LATCH	1	
3		1802010	BOLT - 3/16" X 1" NC STOVE	2	
4		293731001	LINK - DOOR LATCH	1	
5		104024001	LATCH ASSY-R.H. ROTARY	1	
6		296256431	COVER - DOOR LATCH	1	
7		533003	SCREW 10-24X1-1/2 RND HD SLT	4	
8		485001	WASHER-3/16 FLAT	4	
9		400001	NUT-3/16 NC HEX	2	
10		72364001	STRIKER BOLT W/ WASHER	1	
11		293766001	NUT - TIE ROD	1	
12		293737001	PLATE - STRIKER BOLT	1	

Cab-16" Jump Seat Assy Fig 6-6

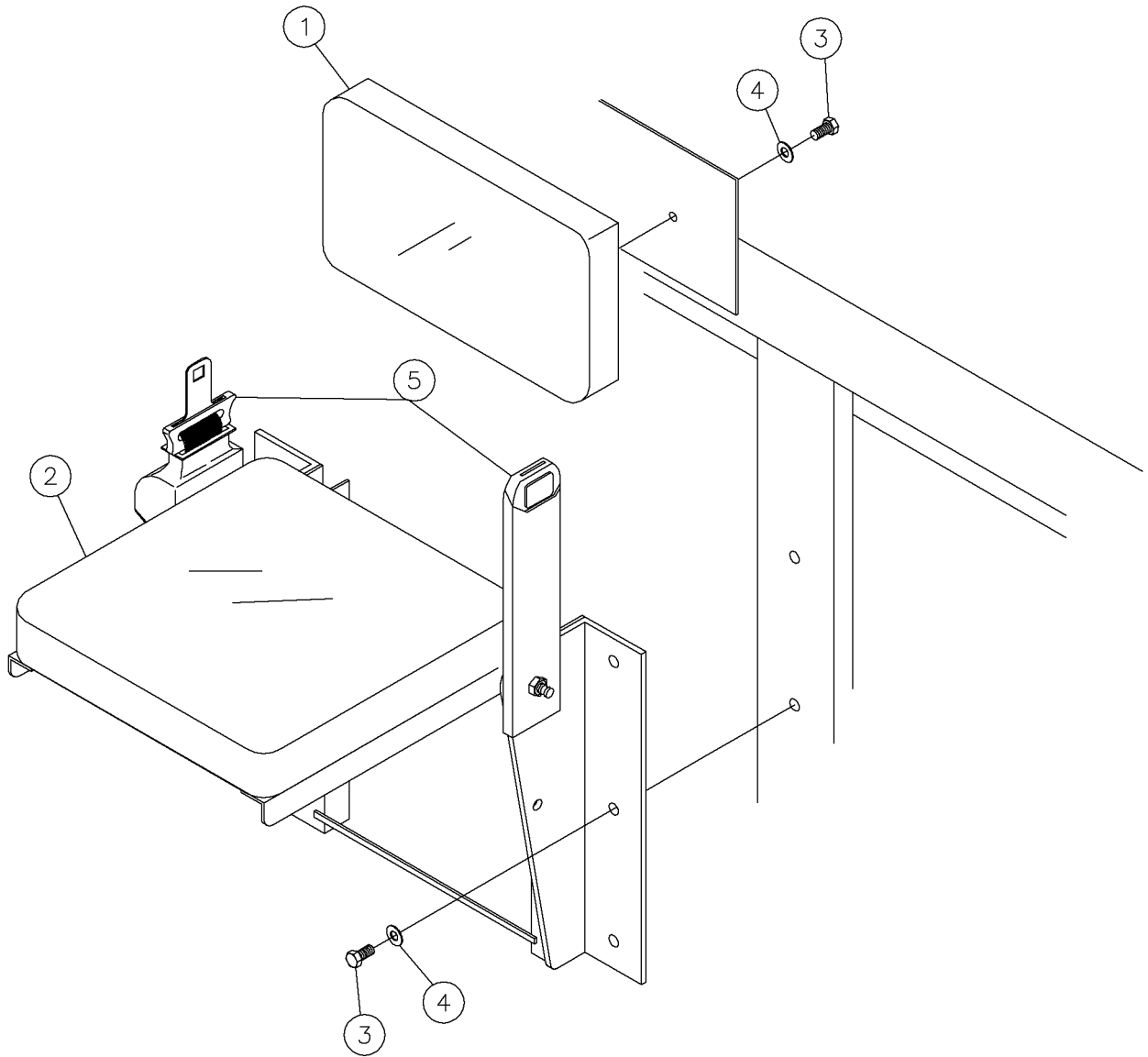

Cab-16" Jump Seat Assy Fig 6-6

REF. NO.	*	PART NO.	DESCRIPTION	QTY.	REMARKS
1		283062001	SEAT BACK ASSEMBLY-JUMP SEAT	1	
2		283006001	SEAT-JUMP 16"	1	
3		235726001	BOLT-3/8-16X3/4 GR8 HEX ZNCPLT	8	
4		235713001	WASHER-3/8 SAE HARD ZINC PLTD	8	
5		296263304	SEAT BELT	1	

Cab-Seat-Mechanical Assy Fig 6-7

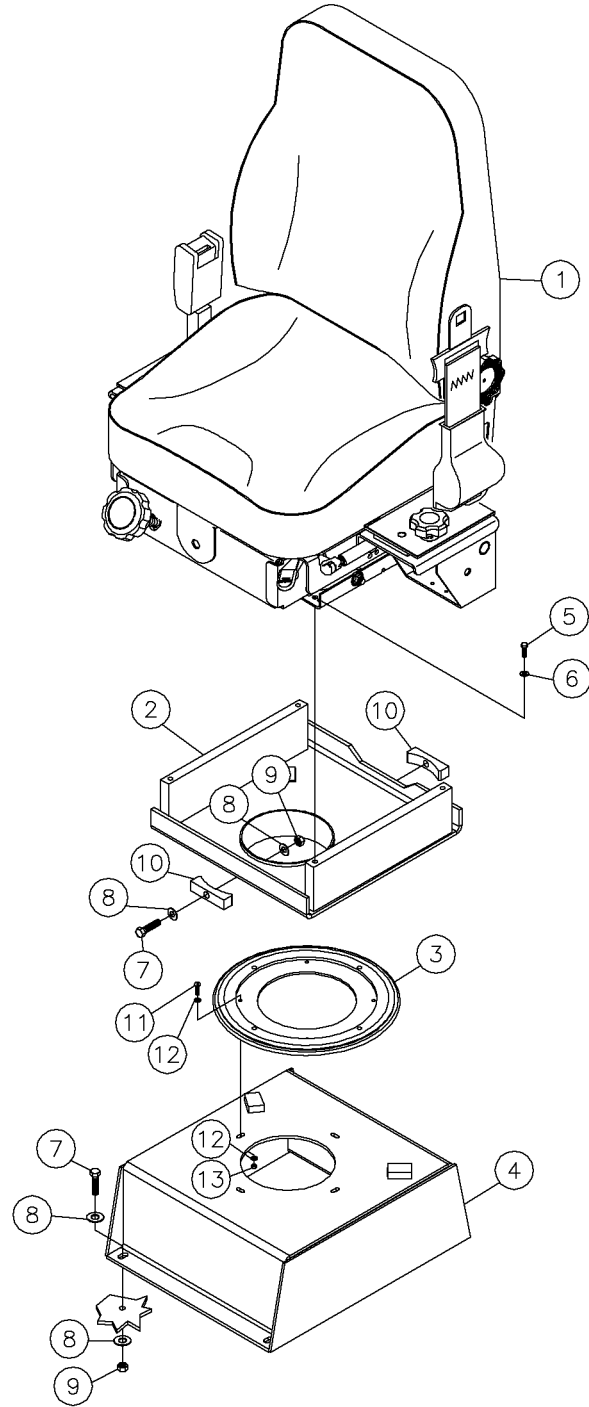

Cab-Seat-Mechanical Assy Fig 6-7

REF. NO.	*	PART NO.	DESCRIPTION	QTY.	REMARKS
1		283000001	SEAT-OPERATOR (MAGNUM 200)	1	Breakdown Fig 12-27
2		293696001	PIVOT - SEAT	1	
3		296256466	BEARING-LAZY SUSAN #12C	1	
4		293699001	SEAT - PEDESTAL	1	
5		235742001	BOLT-5/16-18X3/4 GR8 ZINC PLTD	4	
6		235714001	WASHER-5/16 SAE HARD ZINC PLTD	4	
7		235723001	BOLT-3/8-16X1 1/2 GR8 ZINC PLT	2	
8		235713001	WASHER-3/8 SAE HARD ZINC PLTD	4	
9		235725001	NUT-3/8-16 GR8 ZINC PLTD	2	
10		293693001	PLATE - SEAT MOUNT	2	
11		1802010	BOLT - 3/16" X 1" NC STOVE	4	
12		510337601	WASHER-FLATSTD-.19-.22X.56-.05-YZ	8	
13		510312301	NUT-HEX-10-24-GR2-YZ	4	
14		235727001	BOLT-3/8-16X1 GR8 HEX ZINC PLT	4	

Cab-Side Table Assy Fig 6-8

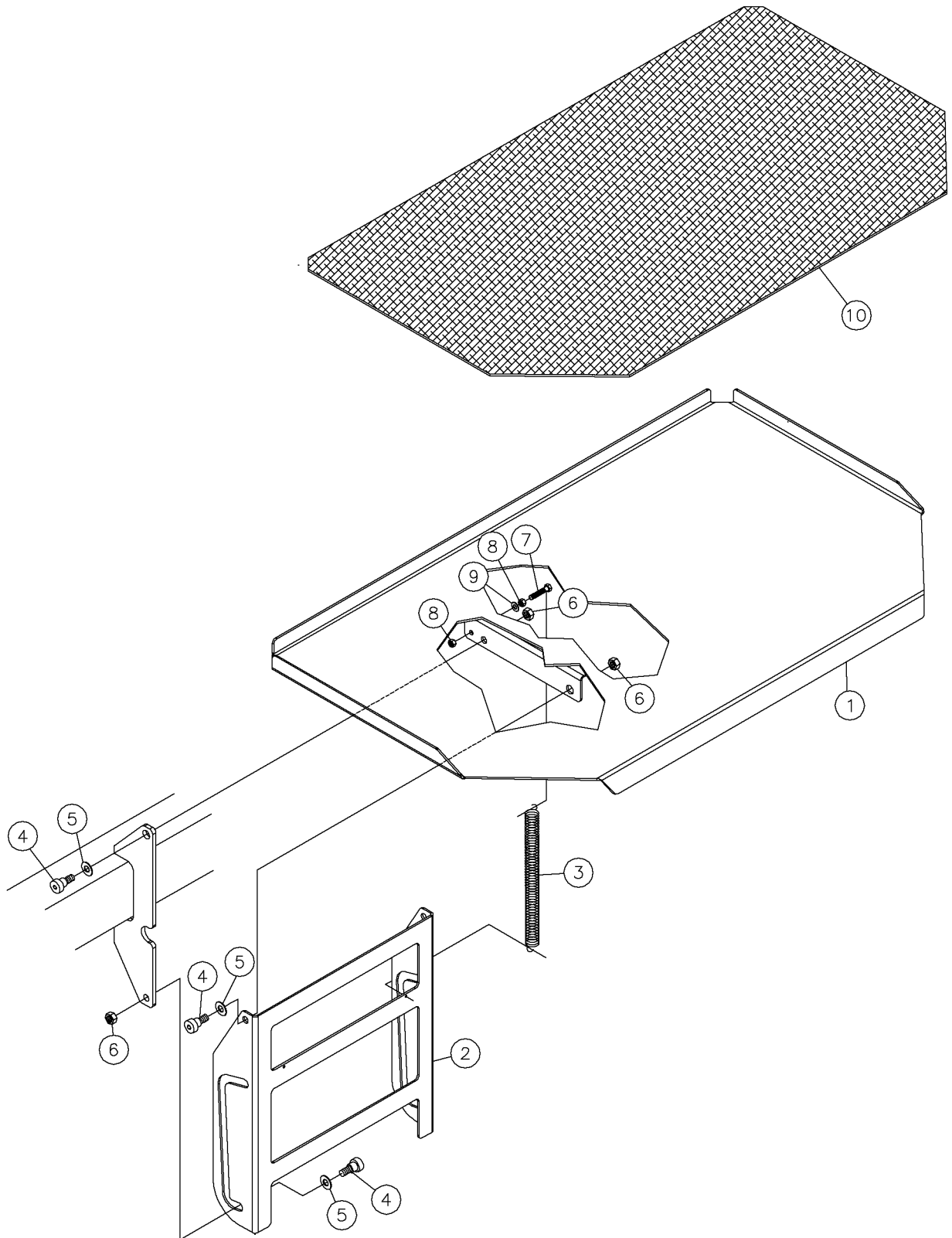

Cab-Side Table Assy Fig 6-8

REF. NO.	*	PART NO.	DESCRIPTION	QTY.	REMARKS
1		296262523	TABLE	1	
2		296262527	PLATE - TABLE BRACE	1	
3		296262541	SPRING - EXTENSION - .44 X 6.0	2	
4		296256038	SCREW - SHSS - .50X.38-.38-16 THD-CZ	4	
5		235713001	WASHER-3/8 SAE HARD ZINC PLTD	4	
6		235725001	NUT-3/8-16 GR8 ZINC PLTD	4	
7		238210001	BOLT - 1/4-20X1 1/2 GR8 HEX ZYC	2	
8		235732001	NUT-1/4-20 GR8 ZINC PLTD	4	
9		510337603	WASHER-FLATSTD-.25-.31X.75-.07-YZ	2	
10		296262618	PAD - TABLE TOP	1	

Cab-Handrail/Step Assy Fig 6-9r01

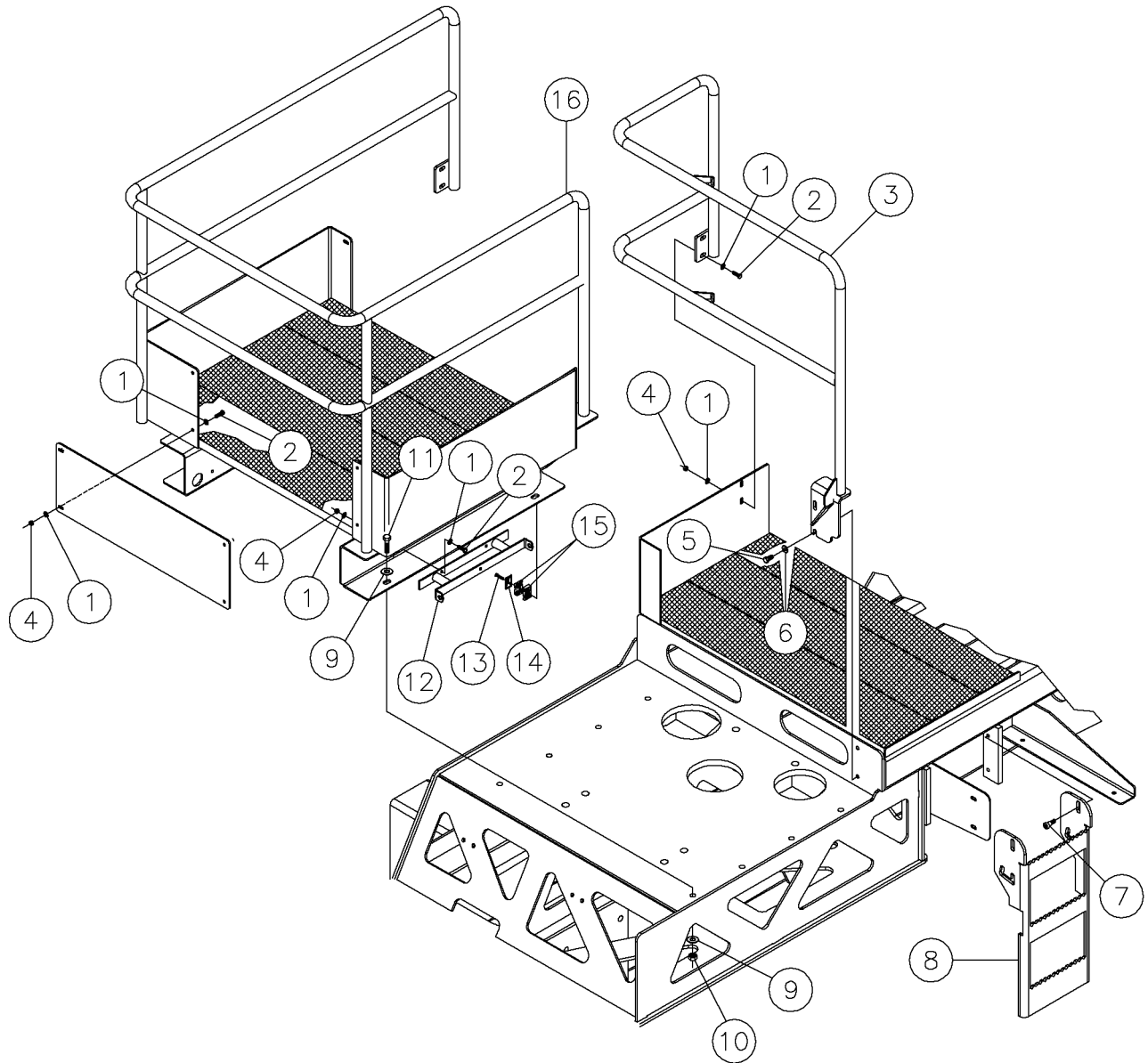

Cab-Handrail/Step Assy Fig 6-9r01

REF. NO.	*	PART NO.	DESCRIPTION	QTY.	REMARKS
		Revision Date	October, 2004		Update In Illustration & Parts List.
1		235713001	WASHER - FLATSTRL - .38 - .41 X .81 - .06-YA-A325	18	
2		235736001	BOLT-3/8-16X1 1/4 ZINC PLTD	9	
3		296266929	HANDRAIL - 300X500	1	With Crane Option
4		235725001	NUT - HEX - .38 - 16 - GR8 - YZ	9	
5		250539001	BOLT-7/16-14 X 1 GR8 HEX Y/ZI	2	
6		250515001	7/16 HARD WASHER SAE Y/ZINC	2	
7		296261520	SCREW-SHSS-.63 X .63 - .50 - 13 THD PLN	4	
8		296261518	PLATE - LADDER	1	
9		235717001	WASHER-3/4 FLAT HARDENED YELLOW ZINC	8	
10		235739001	NUT-3/4-10 GR8 ZINC PLTD	4	
11		243921001	BOLT-3/4 - 10 X 2 1/4 GR8 ZP	4	
12		240791001	BRACKET-VOLTAGE STAKE	1	
13		248031001	BOLT-5/16-18X1 1/4 GR8 ZINC PL	1	
14		67846003	PLATE-TWIN COVER	1	
15		67846005	CLAMP-PAIR-1/2" PIPE/1/4" HYD. HOSE	1	
16		296273782	PLATFORM - NO CRANE OPTION	1	With Out Crane Option

Cab-Handrail/Step Assy Fig 6-9

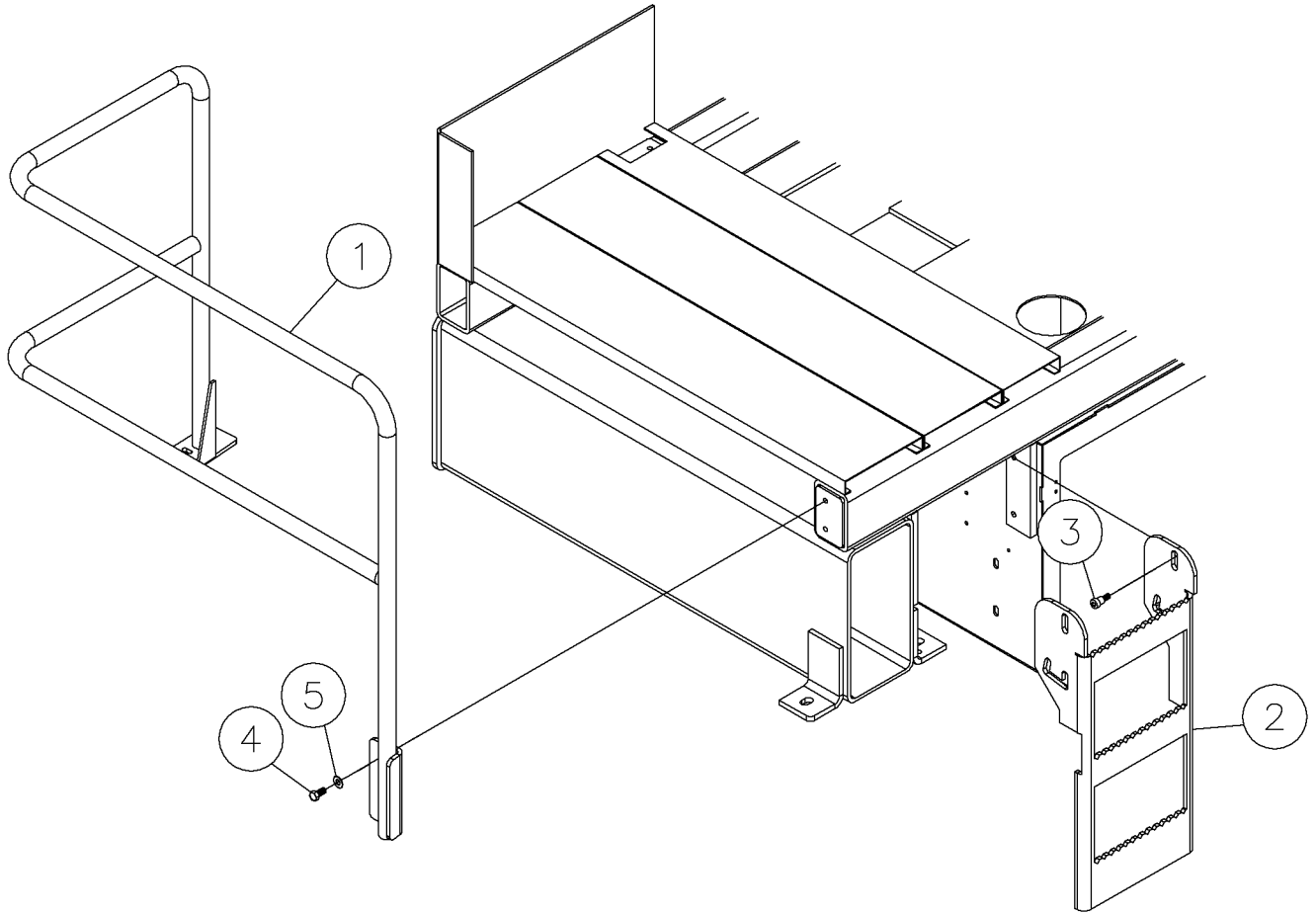

Cab-Handrail/Step Assy Fig 6-9

REF. NO.	*	PART NO.	DESCRIPTION	QTY.	REMARKS
1		296256306	HANDRAIL - WELDMENT	1	
2		296261518	PLATE - LADDER	1	
3		296261520	SCREW-SHSS-.63 X .63 - .50 - 13 THD PLN	4	
4		250539001	BOLT-7/16-14 X 1 GR8 HEX Y/ZI	4	
5		250515001	WASHER-7/16 HARD WASHER SAE Y/ ZINC	4	

Cab-Wiper Motor Assy Fig 6-10r02

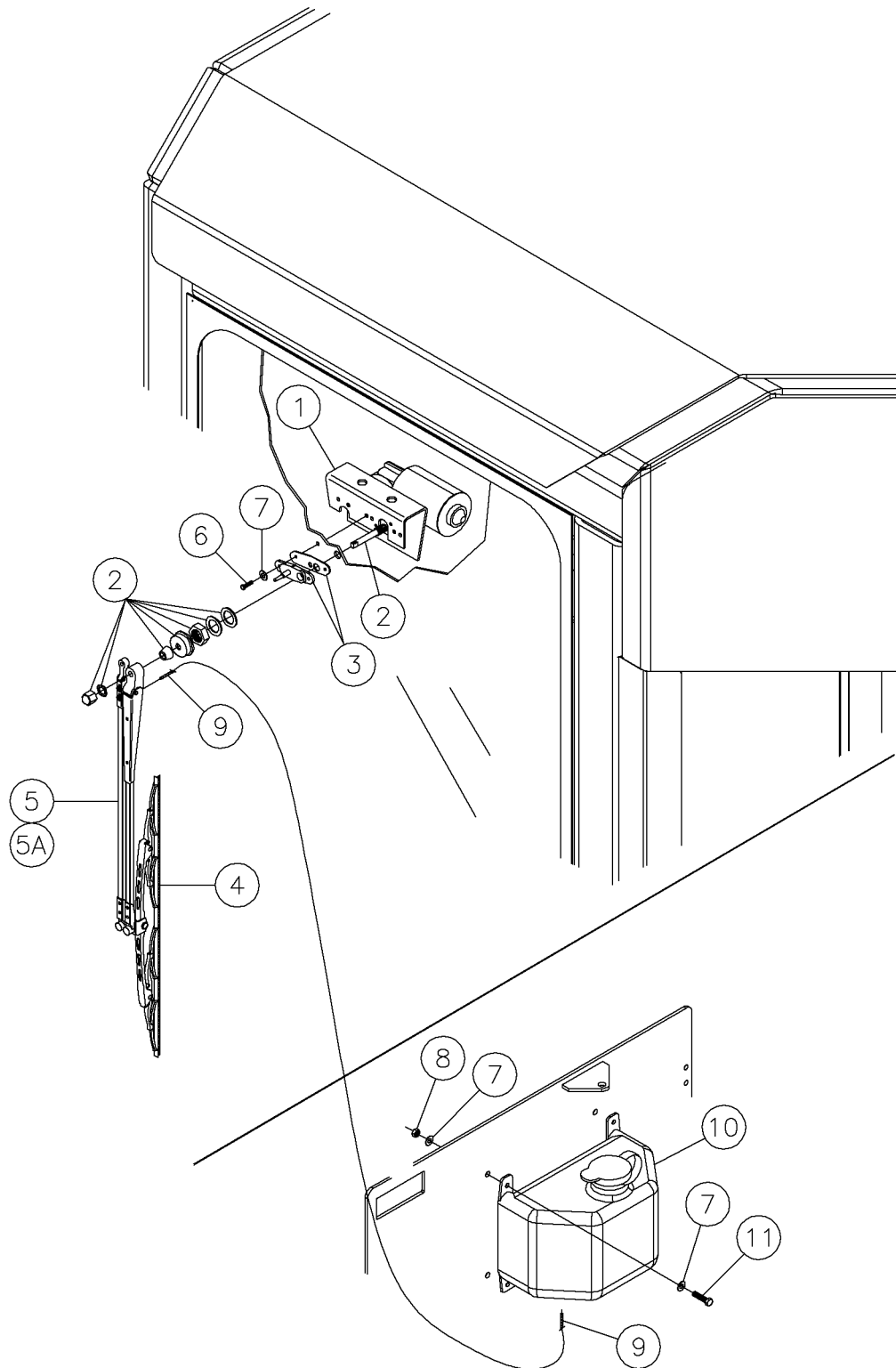

Cab-Wiper Motor Assy Fig 6-10r02

REF. NO.	*	PART NO.	DESCRIPTION	QTY.	REMARKS
		Revision Date	October, 2004		Update In Illustration & Parts List.
1		293582001	WIPER MOTOR ASSEMBLY - 24V	1	
2		293584001	SHAFT - 1.25 PIVOT	1	
3		293654001	ADAPTER - PANTO	1	
4		296262550	BLADE - 16" WIPER	1	
5		296262548	ARM - ADJUSTABLE DRIVE	1	
5A		296262551	KIT - WET ARM WASHER	1	Inc Nozzle, Hose Holders, Rubber hose, Bolt & Lock Nut
6		296275544	SCREW - HCS - .25 - 28 X 1.00 - GR8 - CZ	2	
7		235716001	WASHER - FLATSTRL - .25 -.28 X .63 - .06 - CZ	10	
8		235732001	NUT - HEX - .25 - 20 - GR8 - YZ	4	
9		296275508	HOSE - VACUUM - 7/32 X 4'	1	
10		293589001	TANK - 140 OZ. WINDSHIELD WASHER	1	
11		235735001	BOLT-1/4-20X1 GR8 HEX ZNC PLTD	4	

Cab-Wiper Motor Assy Fig 6-10r01

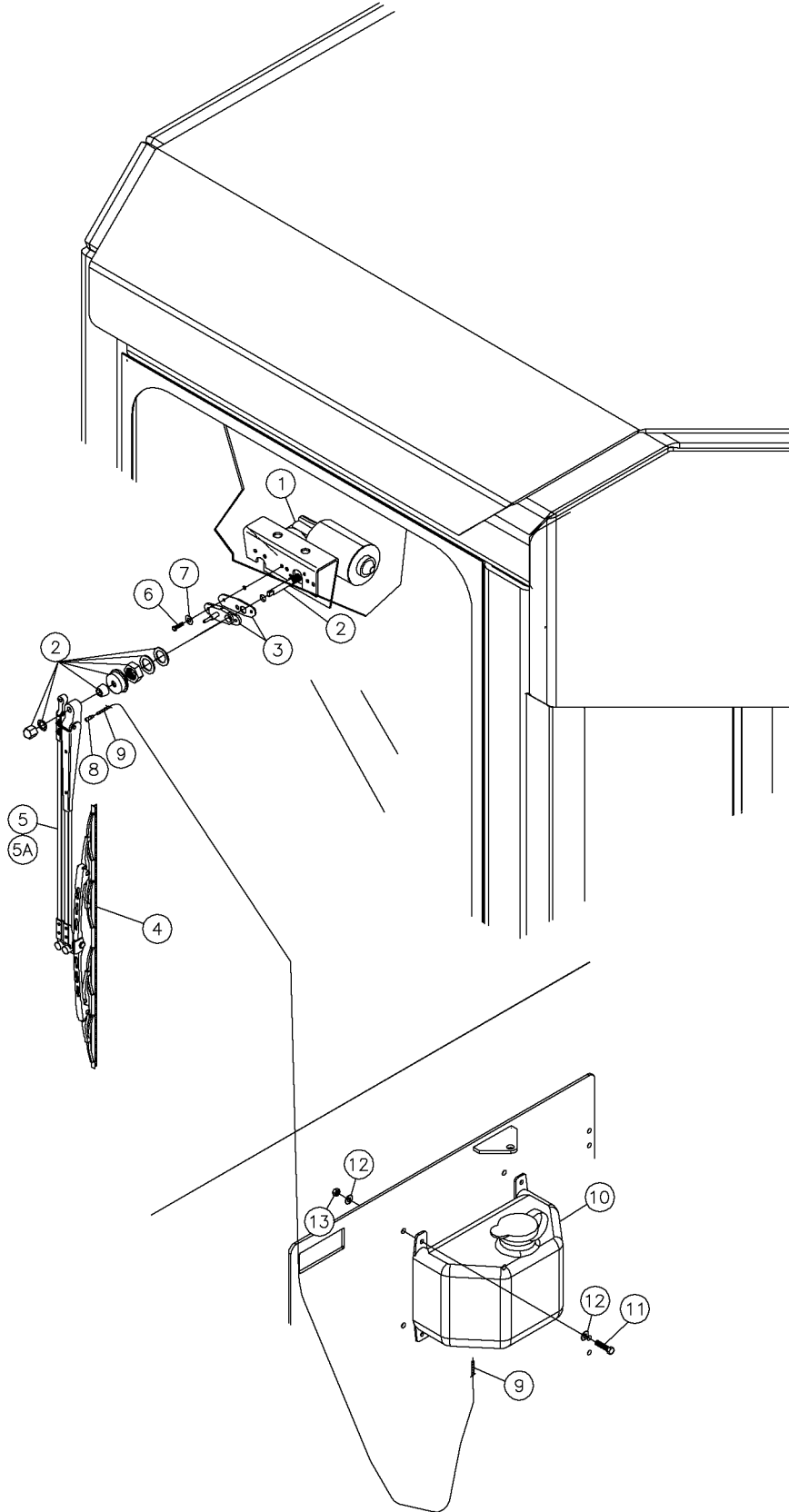

Cab-Wiper Motor Assy Fig 6-10r01

REF. NO.	*	PART NO.	DESCRIPTION	QTY.	REMARKS
		Revision Date	June, 2002		Remove And Add Parts
1		293582001	WIPER MOTOR ASSEMBLY - 24V	1	
2		293584001	SHAFT - 1.25 PIVOT	1	
3		293654001	ADAPTER - PANTO	1	
4		296262550	BLADE - 16" WIPER	1	
5		296262548	ARM - ADJUSTABLE DRIVE	1	
5A		296262551	KIT - WET ARM WASHER	1	Inc Nozzle, Hose Holders, Rubber Hose, Blot, & Lock Nut
6		235735001	BOLT-1/4-20X1 GR8 HEX ZNC PLTD	2	
7		235716001	WASHER-1/4 SAE HARD ZINC PLTD	2	
8	*	296256496	FITTING - STR - 3HB-2HB NYLON	1	
9	*	94108001	HOSE-5/32 WASHER	A/R	P/N Qty Of 1 = 1 Foot
10		293589001	TANK - 140 OZ. WINDSHIELD WASHER	1	
11		235735001	BOLT-1/4-20X1 GR8 HEX ZNC PLTD	4	
12		235716001	WASHER-1/4 SAE HARD ZINC PLTD	8	
13		235732001	NUT-1/4-20 GR8 ZINC PLTD	4	

Cab-Wiper Motor Assy Fig 6-10

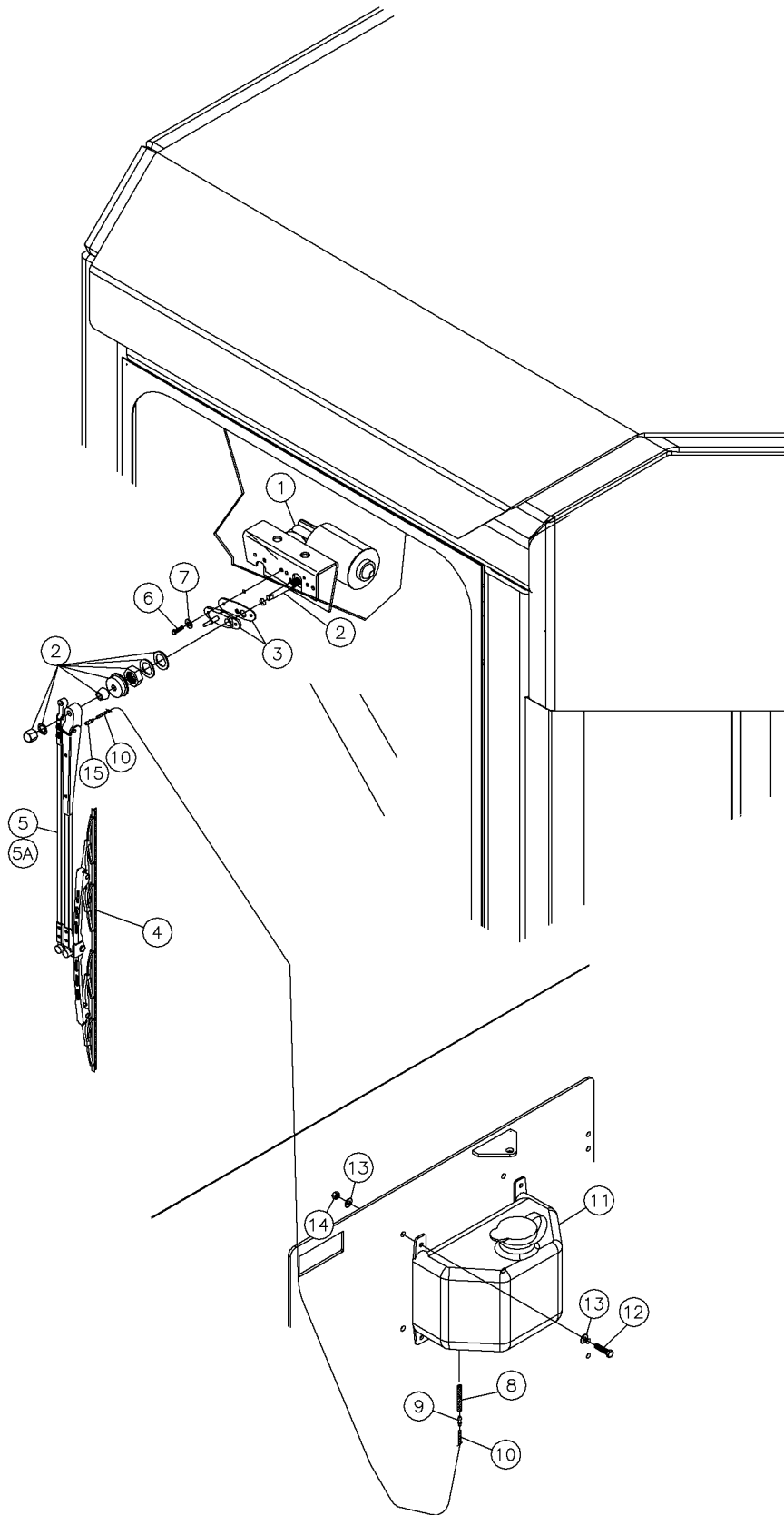

Cab-Wiper Motor Assy Fig 6-10

REF. NO.	*	PART NO.	DESCRIPTION	QTY.	REMARKS
1		293582001	WIPER MOTOR ASSEMBLY - 24V	1	
2		293584001	SHAFT - 1.25 PIVOT	1	
3		293654001	ADAPTER - PANTO	1	
4		296262550	BLADE - 16" WIPER	1	
5		296262548	ARM - ADJUSTABLE DRIVE	1	
5A		296262551	KIT - WET ARM WASHER	1	Inc Nozzle, Hose Holders, Rubber Hose, Blot, & Lock Nut
6		235735001	BOLT-1/4-20X1 GR8 HEX ZNC PLTD	2	
7		235716001	WASHER-1/4 SAE HARD ZINC PLTD	2	
8		296256496	FITTING - STR - 3HB-2HB NYLON	1	
9		94108001	HOSE-5/32 WASHER	A/R	P/N Qty Of 1 = 1 Foot
10		293589001	TANK - 140 OZ. WINDSHIELD WASHER	1	
11		235735001	BOLT-1/4-20X1 GR8 HEX ZNC PLTD	4	
12		235716001	WASHER-1/4 SAE HARD ZINC PLTD	8	
13		235732001	NUT-1/4-20 GR8 ZINC PLTD	4	

Cab Fan Assy Fig 6-11

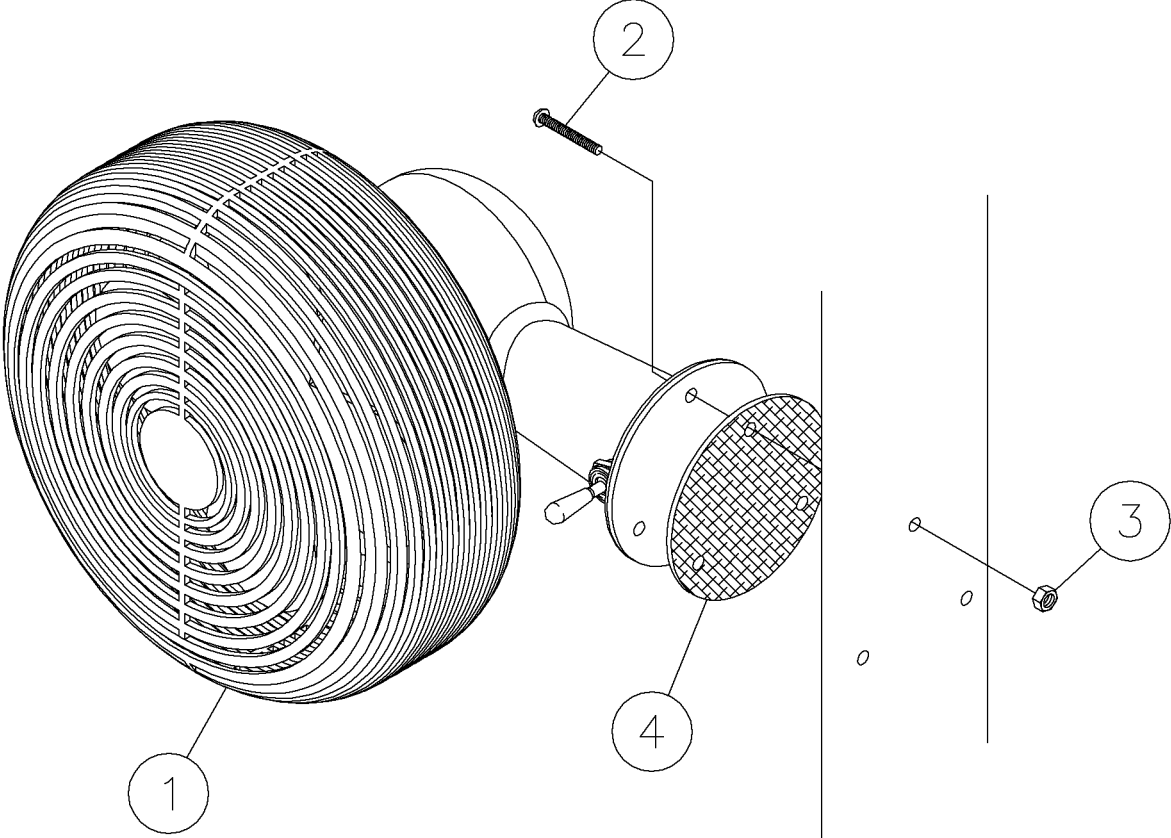

Cab Fan Assy Fig 6-11

REF. NO.	*	PART NO.	DESCRIPTION	QTY.	REMARKS
1		296256395	FAN - 24V CAB	1	Inc Ref No 4
2		1802010	BOLT - 3/16" X 1" NC STOVE	3	
3		400001	NUT-3/16 NC HEX	3	
4		NSS	GASKET	1	

Cab-Air Conditioner Component Coolant Diagram Fig 6-12

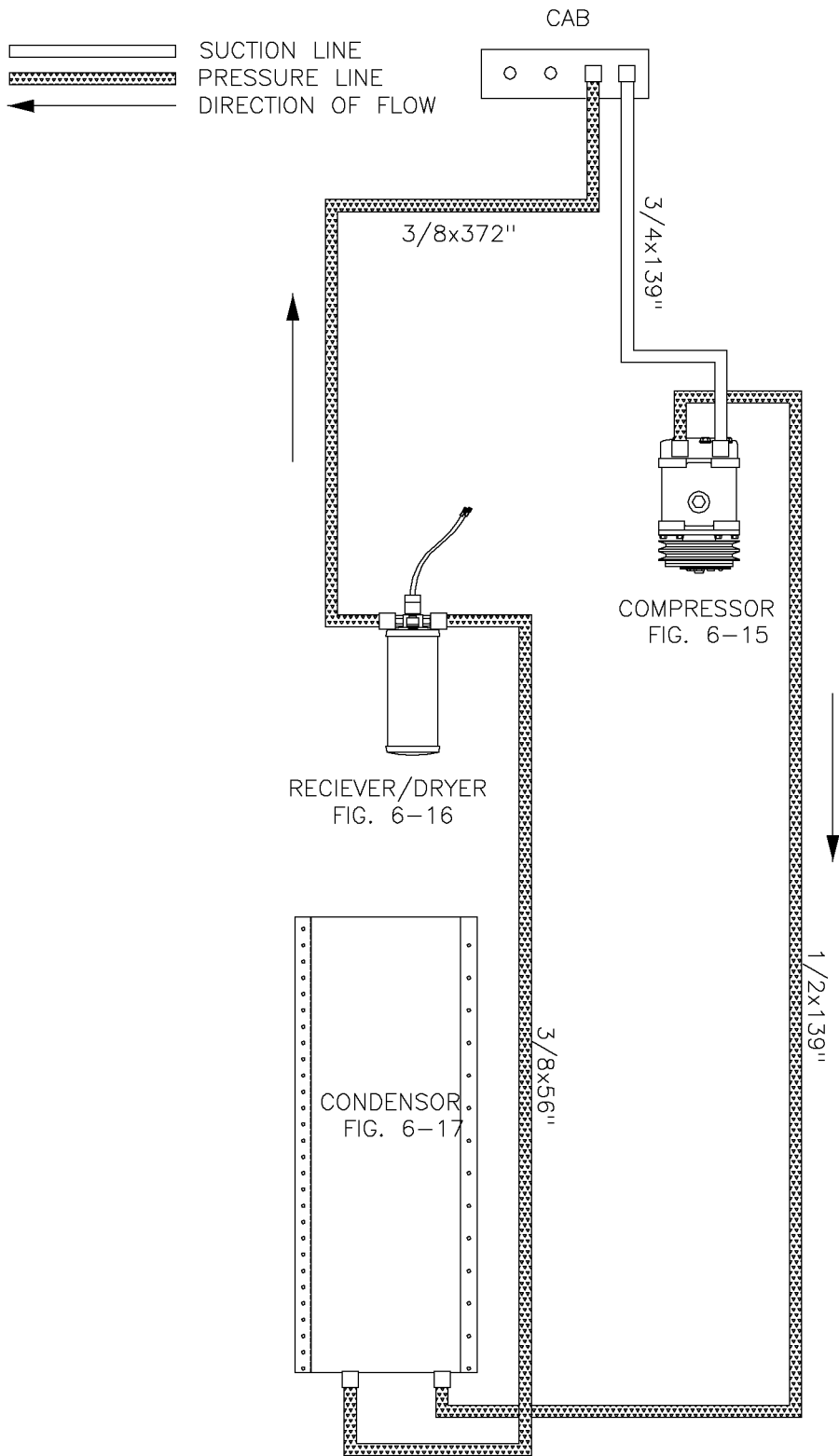

Cab-Air Conditioner Component Coolant Diagram Fig 6-12

REF. NO.	*	PART NO.	DESCRIPTION	QTY.	REMARKS

Cab-Heater/Air Conditioner Assy Fig 6-13

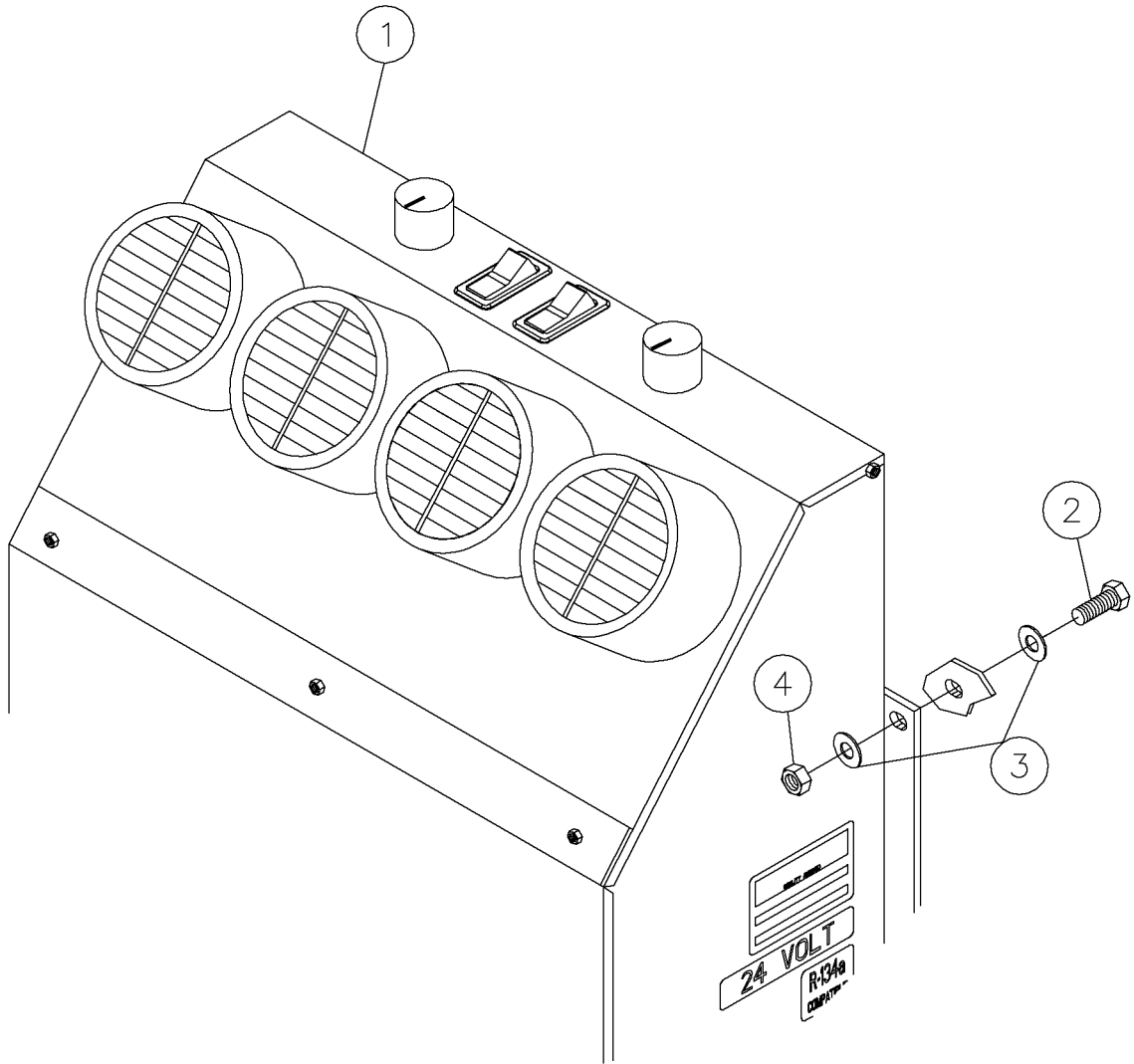

Cab-Heater/Air Conditioner Assy Fig 6-13

REF. NO.	*	PART NO.	DESCRIPTION	QTY.	REMARKS
1		293570001	EVAPORATOR-AIR COND W/ HEATHER-24V	1	Breakdown On Fig 12-24
2		235727001	BOLT-3/8-16X1 GR8 HEX ZINC PLT	6	
3		235713001	WASHER-3/8 SAE HARD ZINC PLTD	12	
4		235725001	NUT-3/8-16 GR8 ZINC PLTD	6	

Cab-Air Conditioner Filter Assy Fig 6-14

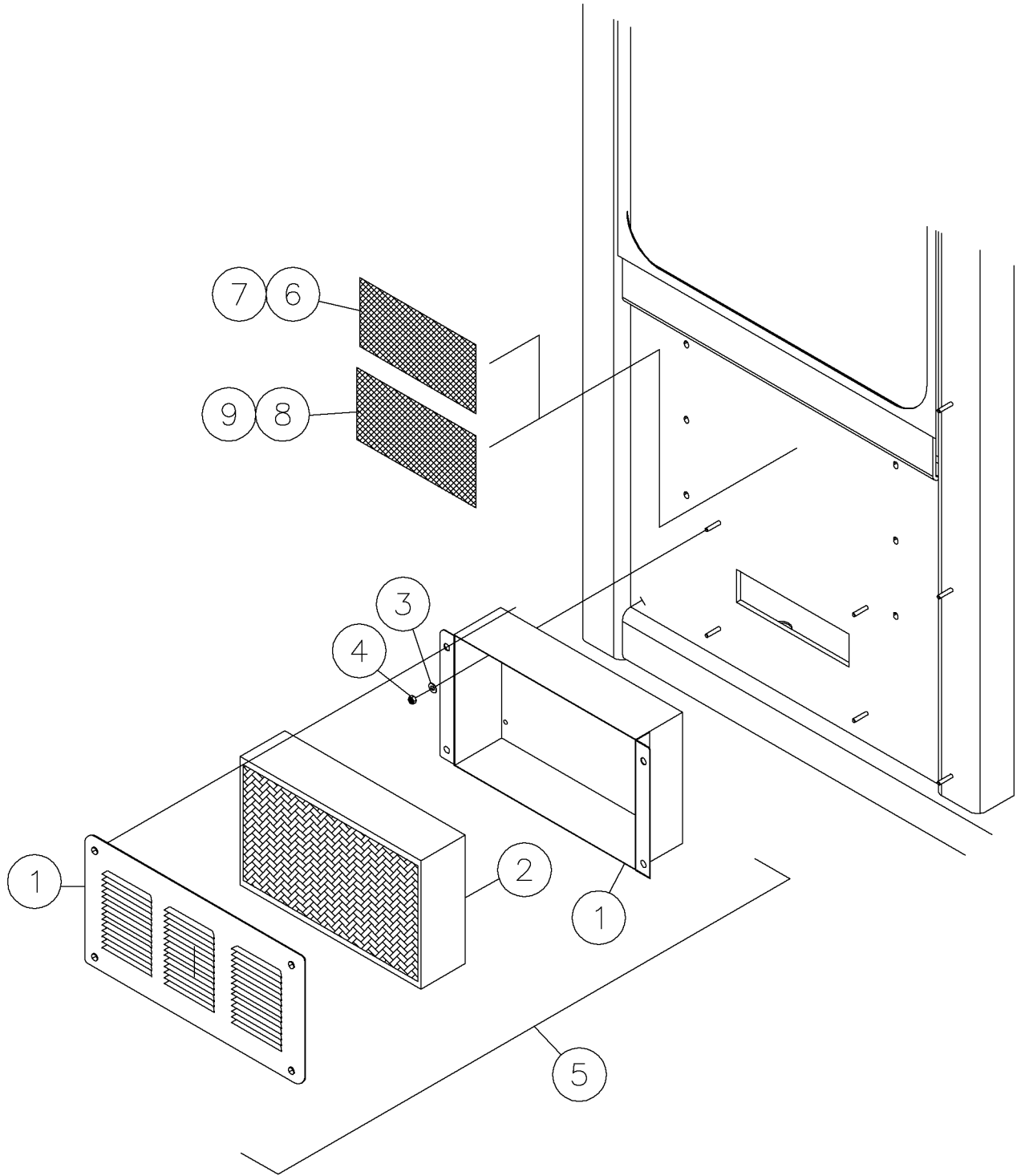

Cab-Air Conditioner Filter Assy Fig 6-14

REF. NO.	*	PART NO.	DESCRIPTION	QTY.	REMARKS
1		296253496	FILTER BOX	1	
2		296253497	FILTER	1	
3		235714001	WASHER-5/16 SAE HARD ZINC PLTD	4	
4		235741001	NUT-5/16-18 GR8 ZINC PLTD	4	
5		296256393	FILTER - AC FRESH AIR	1	Inc Ref No's 1 & 2
6		7000B623	DECAL - DANGER ELECTRIC SHOCK	1	
7		700IB623	DECAL - DANGER ELECTRIC SHOCK	1	International
8		7000B617	DECAL - DANGER POWER LINES	1	
9		700IB617	DECAL - DANGER POWER LINES	1	International

Cab-Compressor Assy Fig 6-15

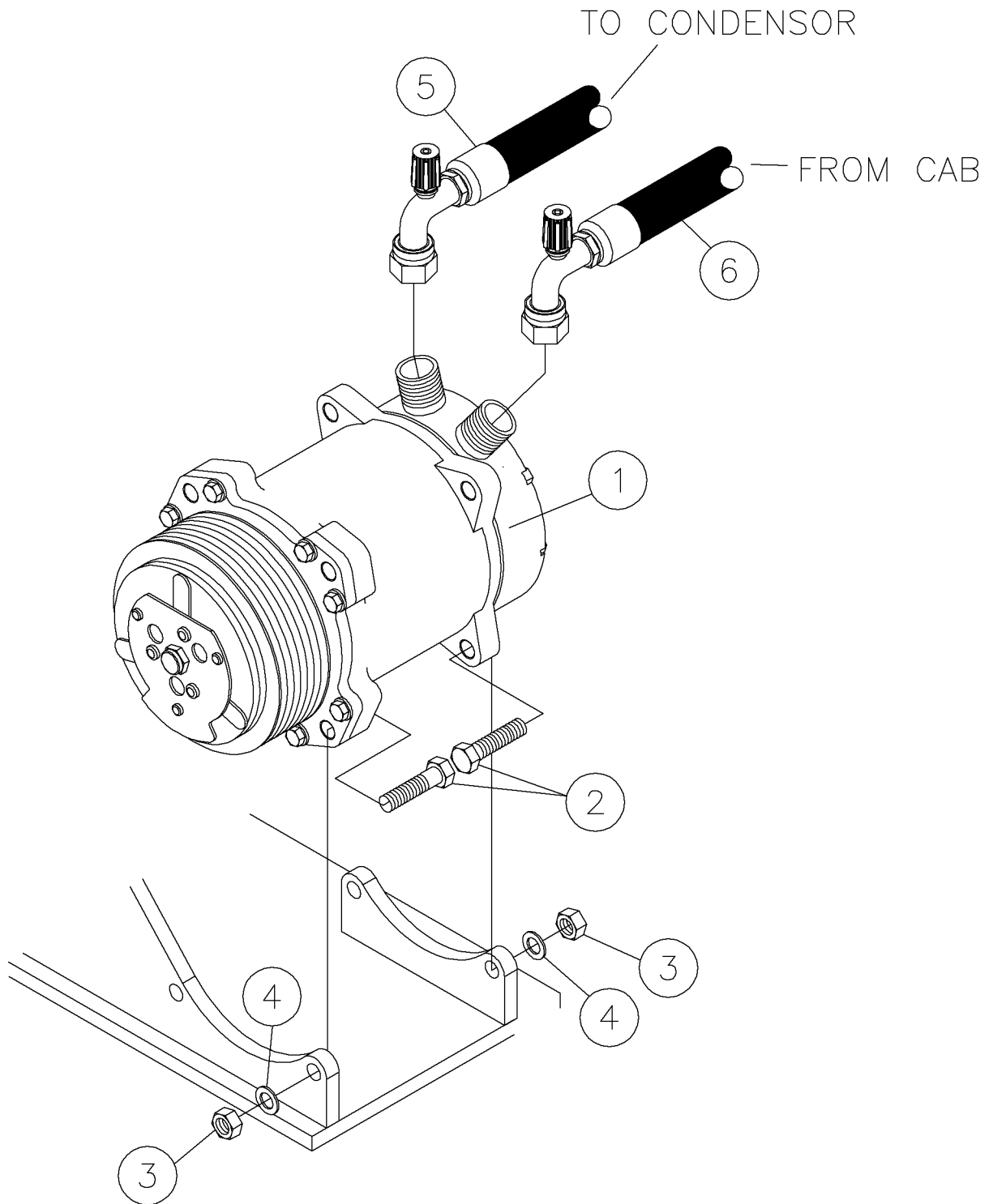

Cab-Compressor Assy Fig 6-15

REF. NO.	*	PART NO.	DESCRIPTION	QTY.	REMARKS
1		296262584	COMPRESSOR - K POLY - V 8-RIB 24V AC	1	
2		235723001	BOLT-3/8-16X1 1/2 GR8 ZINC PLT	4	
3		235725001	NUT-3/8-16 GR8 ZINC PLTD	4	
4		235713001	WASHER-3/8 SAE HARD ZINC PLTD	4	
5		296256396	HOSE - HVAC CONDENSER TO COMPRESSOR	1	
6		296256397	HOSE - HVAC COMPRESSOR TO EVAPORATOR	1	

Cab-Receiver Dryer Assy Fig 6-16

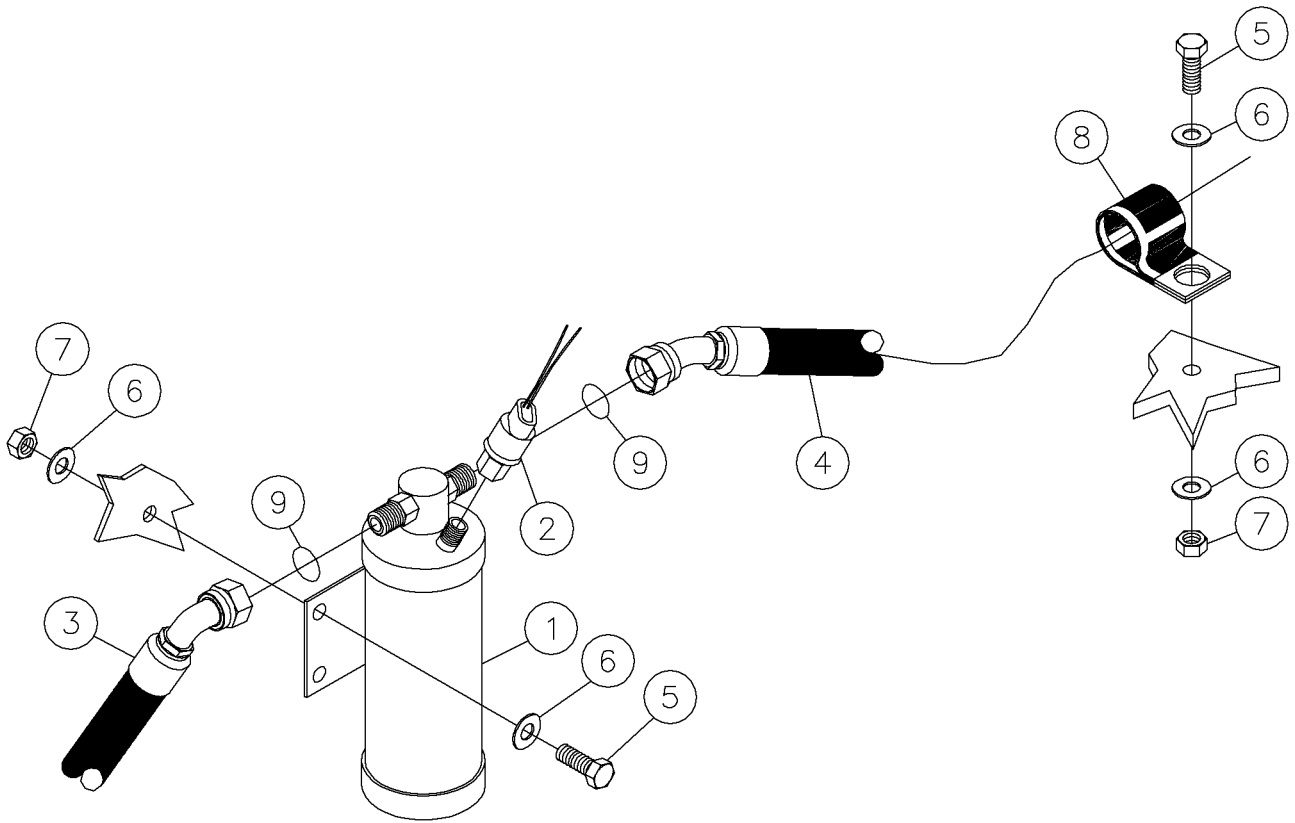

Cab-Receiver Dryer Assy Fig 6-16

REF. NO.	*	PART NO.	DESCRIPTION	QTY.	REMARKS
1		296256394	DRYER - AC RECEIVER	1	
2		293574001	SWITCH-LOW/HIGH PRESSURE	1	
3		296256398	HOSE - HVAC CONDENSER TO DRYER	1	
4		296256399	HOSE- HVAC DRYER TO EVAPORATOR	1	
5		235727001	BOLT-3/8-16X1 GR8 HEX ZINC PLT	5	
6		235713001	WASHER-3/8 SAE HARD ZINC PLTD	10	
7		235725001	NUT-3/8-16 GR8 ZINC PLTD	5	
8		2595007	HOSE CLAMP - TS7J 3/4"	3	
9		296263374	O-RING	2	

Cab-Air Conditioner Condenser Assy Fig 6-17r01

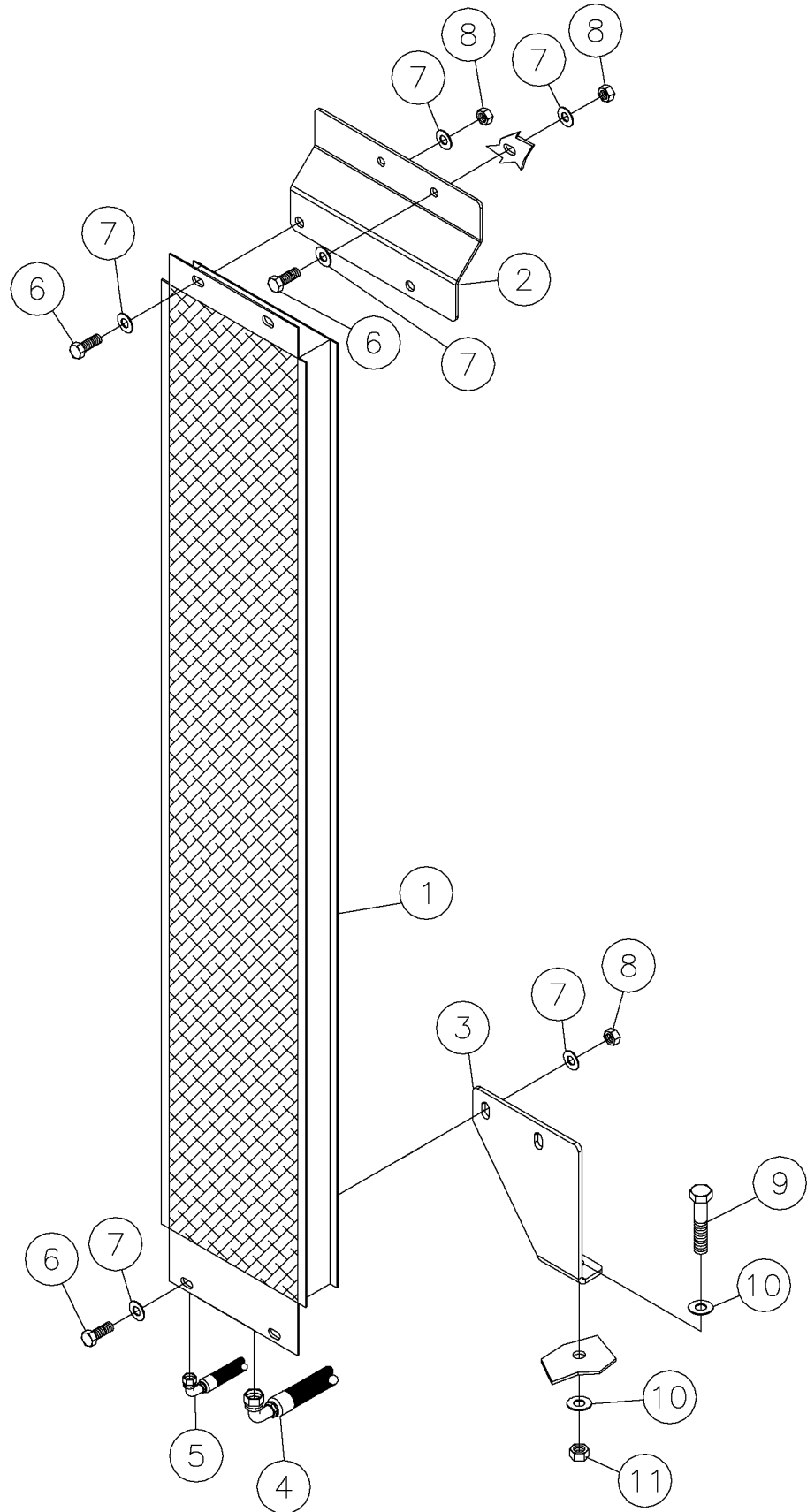

Cab-Air Conditioner Condenser Assy Fig 6-17r01

REF. NO.	*	PART NO.	DESCRIPTION	QTY.	REMARKS
		Revision Date	June, 2002		Update In Illustration & Parts List.
1		296256312	CONDENSER - BA7-5119	1	
2	*	296257389	MOUNT - AC CONDENSER UPPER	1	
3	*	296257388	MOUNT - AC CONDENSER LOWER	1	
4		296256396	HOSE - HVAC CONDENSER TO COMPRESSOR	1	
5		296256398	HOSE - HVAC CONDENSER TO DRYER	1	
6		235727001	BOLT-3/8-16X1 GR8 HEX ZINC PLT	6	
7		235713001	WASHER-3/8 SAE HARD ZINC PLTD	12	
8		235725001	NUT-3/8-16 GR8 ZINC PLTD	6	
9		381024	BOLT-7/16-14X2 1/2 GR8 HEX HD	1	
10		250515001	7/16 HARD WASHER SAE Y/ZINC	2	
11		233459001	NUT-7/16-14 GR.8 HEX YZ	1	

Cab-Air Conditioner Condenser Assy Fig 6-17

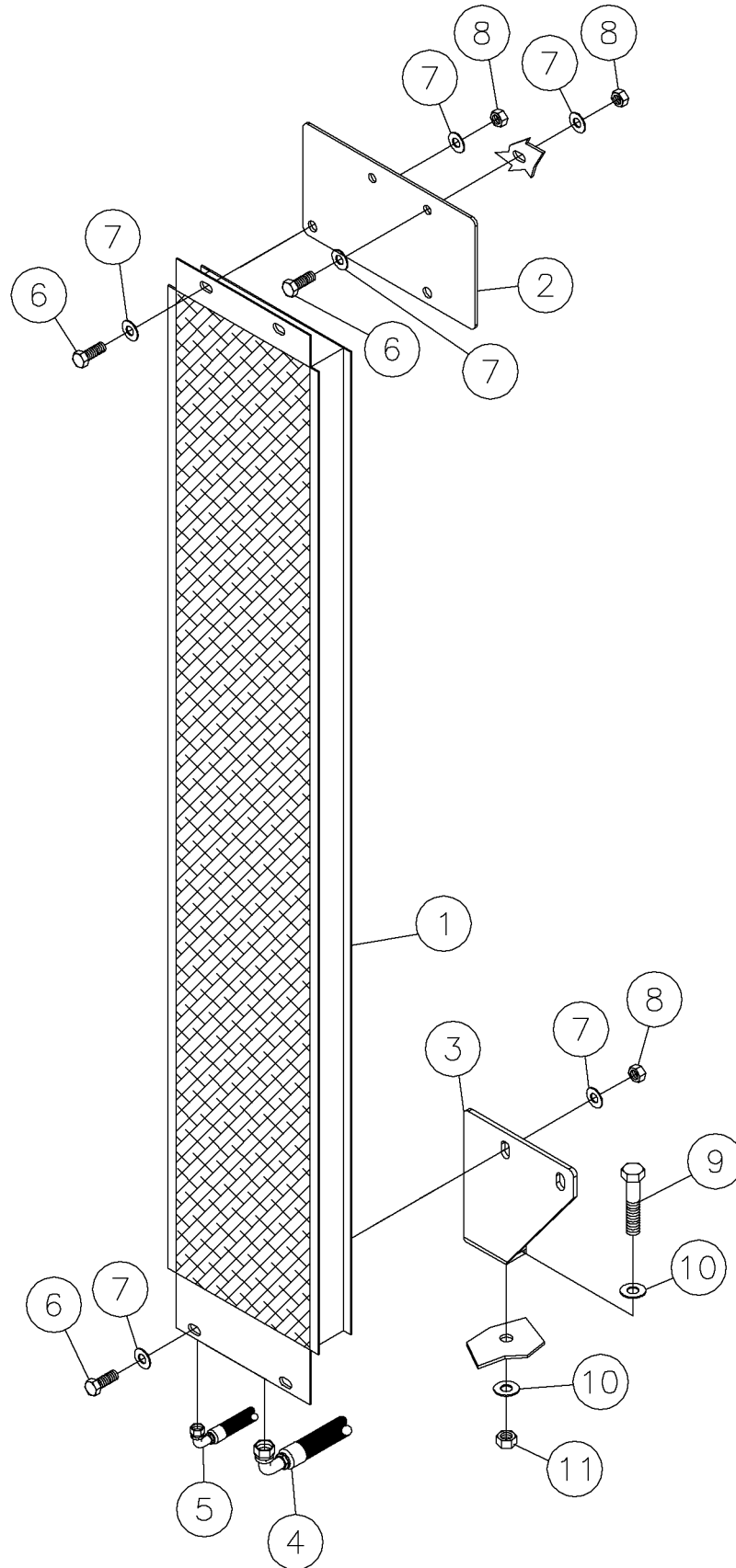

Cab-Air Conditioner Condenser Assy Fig 6-17

REF. NO.	*	PART NO.	DESCRIPTION	QTY.	REMARKS
1		296256312	CONDENSER - BA7-5119	1	
2		296256376	PLATE - AC CONDENSER MOUNT	1	
3		296256467	MOUNT - AC CONDENSER	1	
4		296256396	HOSE - HVAC CONDENSER TO COMPRESSOR	1	
5		296256398	HOSE - HVAC CONDENSER TO DRYER	1	
6		235727001	BOLT-3/8-16X1 GR8 HEX ZINC PLT	6	
7		235713001	WASHER-3/8 SAE HARD ZINC PLTD	12	
8		235725001	NUT-3/8-16 GR8 ZINC PLTD	6	
9		381024	BOLT-7/16-14X2 1/2 GR8 HEX HD	1	
10		250515001	7/16 HARD WASHER SAE Y/ZINC	2	
11		233459001	NUT-7/16-14 GR.8 HEX YZ	1	

Harness Cap Assy Fig 6-18r01

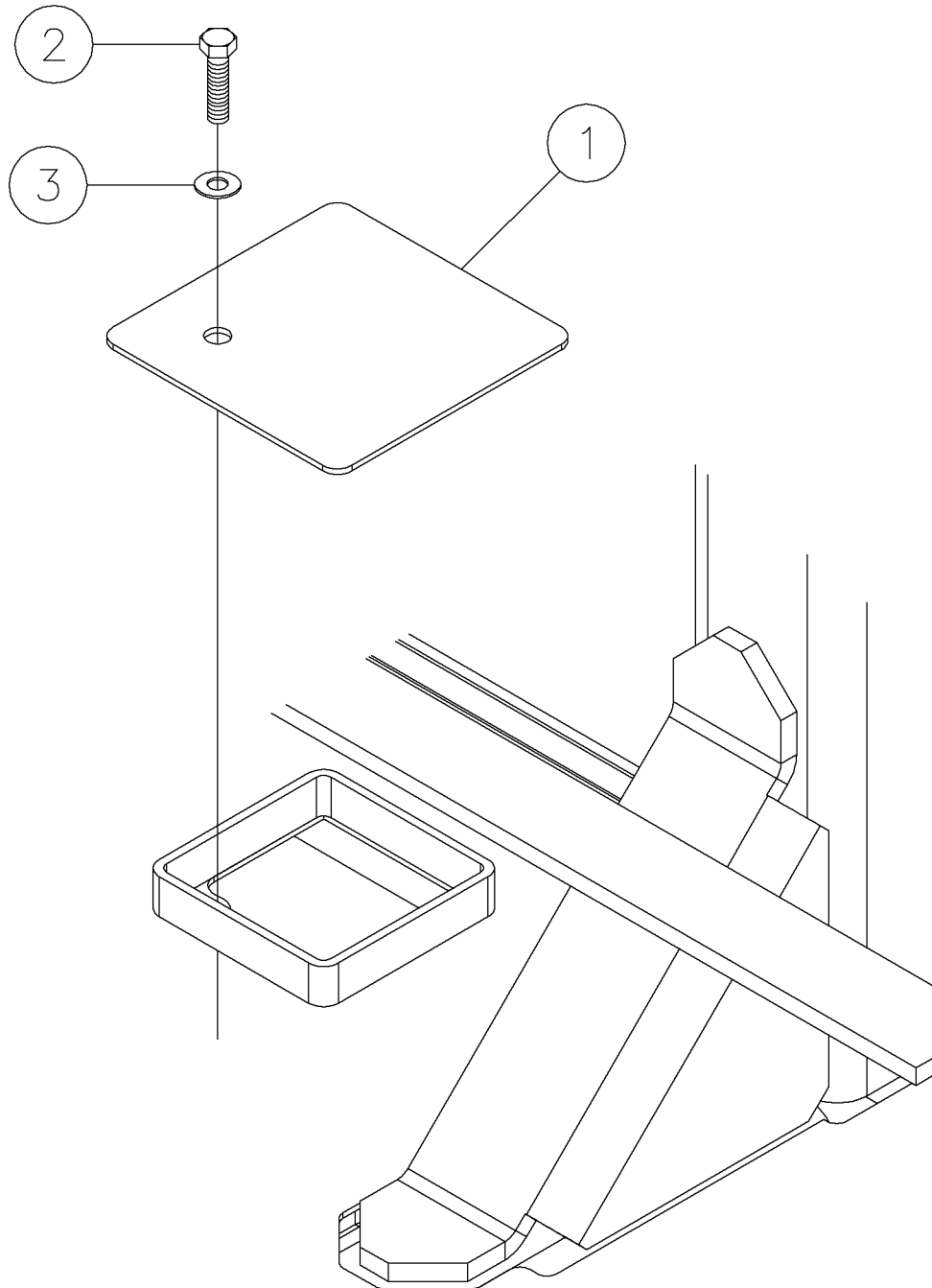

Harness Cap Assy Fig 6-18r01

REF. NO.	*	PART NO.	DESCRIPTION	QTY.	REMARKS
		Revision Date	October, 2004		Update In Illustration & Parts List.
1		296257374	WELDMENT - HARNESS CAP	1	
2		235723001	SCREW - HCS -.38 - 16 X 1.50 - GR8 - YZ	1	
3		235713001	WASHER - FLATSTRL - .38 - .41 X .81 - .06-YA-A325	1	

Harness Cap Assy Fig 6-18

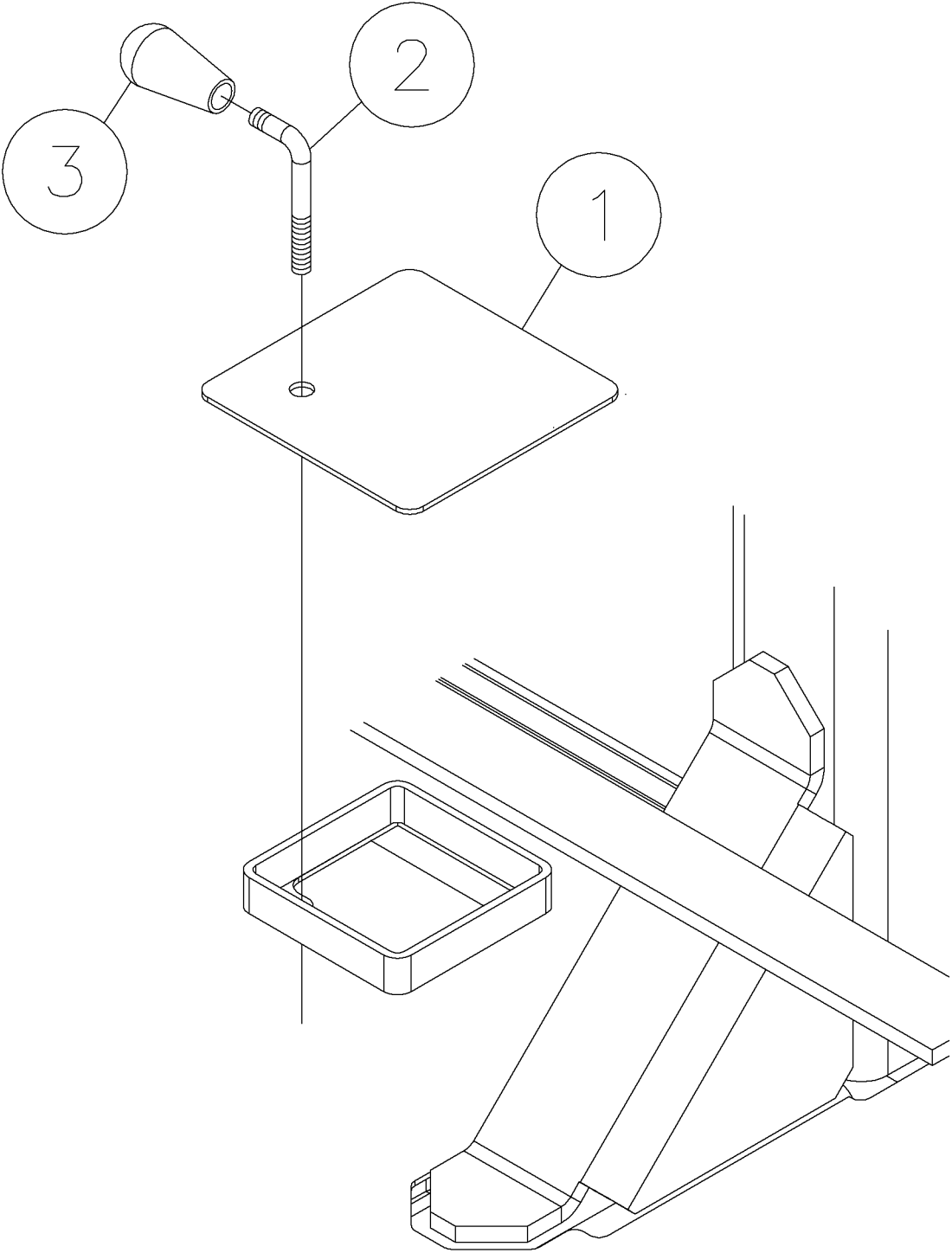

Harness Cap Assy Fig 6-18

REF. NO.	*	PART NO.	DESCRIPTION	QTY.	REMARKS
		Revision Date	June, 2002		Add New Figure
1		296257374	WELDMENT - HARNESS CAP	1	
2		296257375	BAR - THREADED CAP	1	
3		208696001	HANDLE-VALVE CONTROL	1	

Control/Electrical-Wire Harness Assy Fig 7-1r02

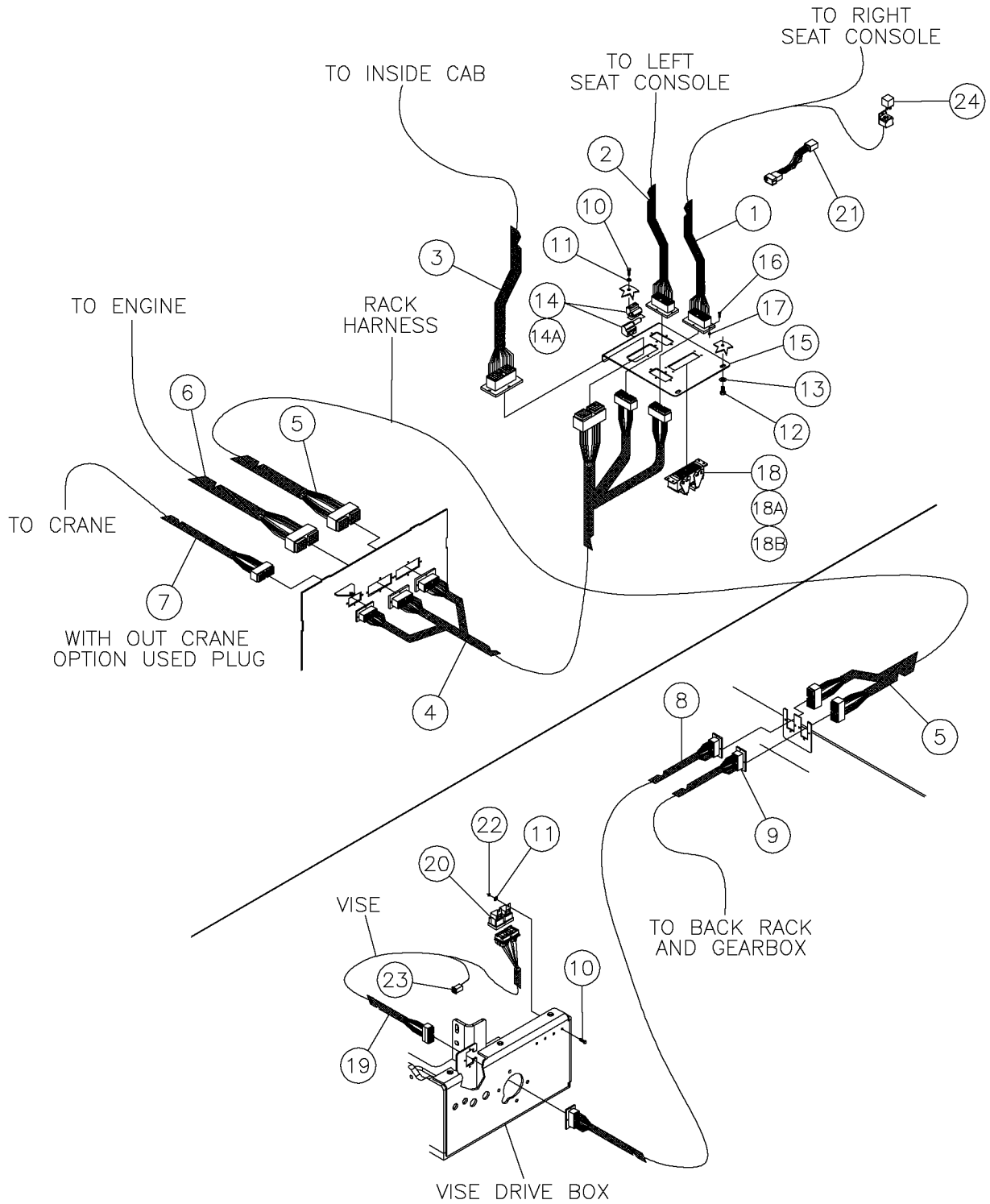

Control/Electrical-Wire Harness Assy Fig 7-1r02

REF. NO.	*	PART NO.	DESCRIPTION	QTY.	REMARKS
		Revision Date	October, 2004		Update In Illustration & Parts List.
1		283222001	WIRE HARNESS - RIGHT ARM REST PHASE II	1	
2		283221001	WIRE HARNESS - LEFT ARMREST PHASE II	1	
3		283220001	WIRE HARNESS - CAB PHASE II	1	
4		283223001	WIRE HARNESS - MAIN	1	
5		283228001	WIRING HARNESS - RACK	1	
6		283225001	HARNESS - ENGINE PHASE II	1	
7		283196001	WIRING HARNESS - CRANE	1	With Out Crane Used A Plug
8		283226001	WIRING HARNESS - FRONT RACK	1	
9		283227001	WIRING HARNESS - REAR RACK	1	
10		235734001	BOLT-1/4-20X3/4 GR8 ZINC PLTD	12	
11		235716001	WASHER - FLATSTRL - .25 - .28 X .63 - .06 - CZ	12	
12		235726001	BOLT-3/8-16X3/4 GR8 HEX ZNCPLT	2	
13		235713001	WASHER - FLATSTRL - .38 - .41 X .81 - .06-YA-A325	2	
14		224782001	HINGE-NYLON LIFT OFF 1/4" THD	1	
14A		224781001	HINGE-NYLON LIFT OFF 1/4" THD	1	
15		293729001	PLATE - ELECTRICAL BULKHEAD	1	
16		1802006	BOLT-10-24 X 3/4 RND HD STOVE	18	
17		400001	NUT-3/16 NC HEX	18	
18		296252125	POS- E -KON DUST COVER W/LANYARD	1	
18A		296252105	BASE - PANEL MOUNT W/COVER	1	
18B		296256675	INSERT - MALE	1	
19		283231001	WIRE HARNESS - VISE PHASE II	1	
20		283181001	RELAY-24V SPDT C-FORM W/RESISTOR	2	
21		283145001	24VDC RELAY ASSEMBLY-REMOTE MUD CONTROL	1	
22		235741001	NUT - HEX - .31 - 18 - GR8 -YZ	4	
23		282531001	MODULE - DEUTSCH DT06-6S 3AMP DIODE	1	
24		283181001	RELAY-24V SPDT C-FORM W/RESISTOR	1	

Control/Electrical-Wire Harness Assy Fig 7-1r01

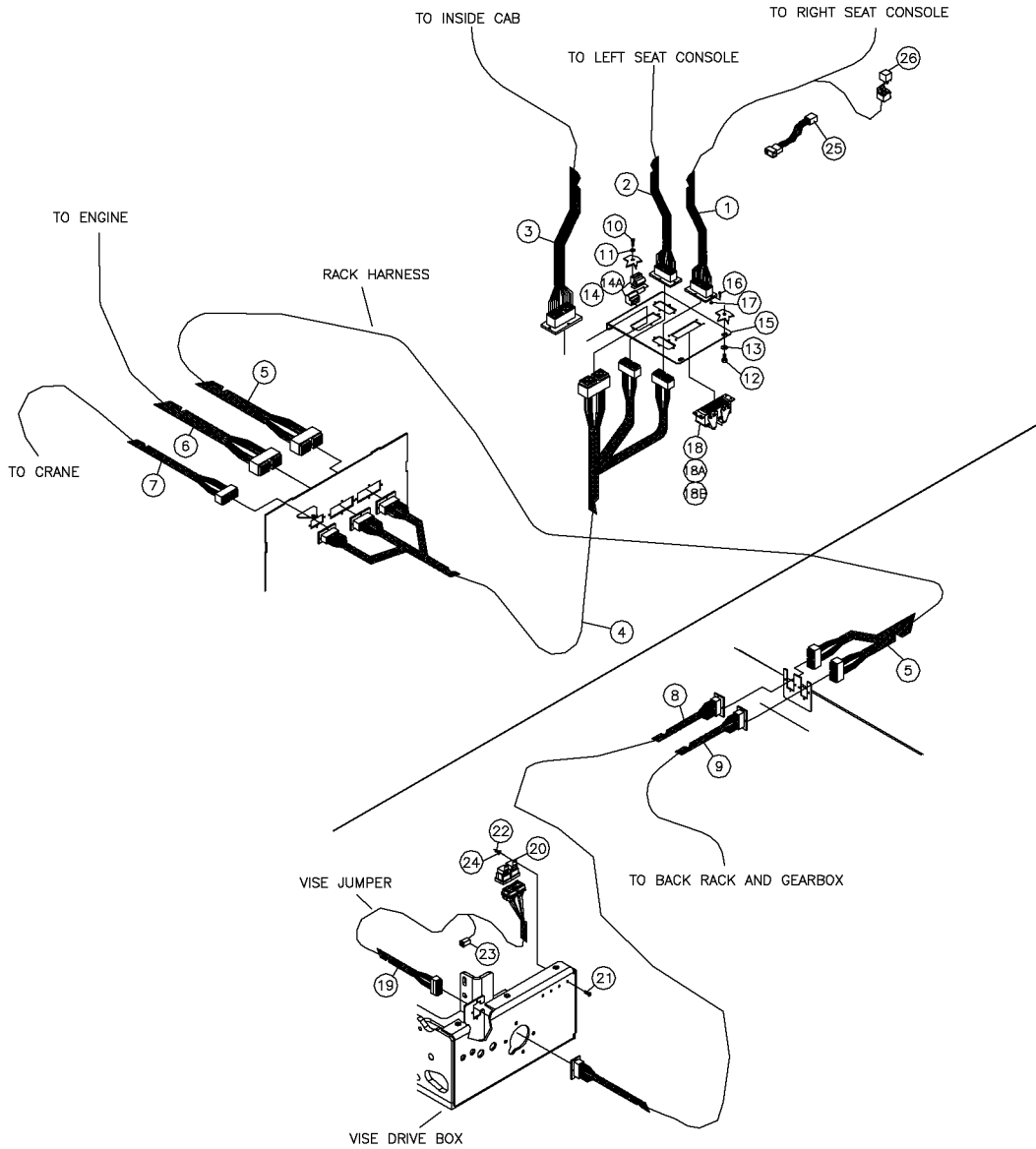

Control/Electrical-Wire Harness Assy Fig 7-1r01

REF. NO.	*	PART NO.	DESCRIPTION	QTY.	REMARKS
		Revision Date	June, 2002		Update In Illustration & Parts List.
1	*	283194001	WIRING HARNESS - RIGHT ARMREST	1	
2	*	283193001	WIRING HARNESS - LEFT ARMREST	1	
3	*	283192001	WIRING HARNESS - CAB	1	
4	*	283195001	WIRING HARNESS - MAIN	1	
5	*	283200001	WIRING HARNESS - RACK	1	
6	*	283197001	WIRING HARNESS - ENGINE	1	
7	*	283196001	WIRING HARNESS - CRANE	1	
8	*	283198001	WIRING HARNESS - FRONT RACK	1	
9	*	283199001	WIRING HARNESS - REAR RACK	1	
10		235734001	BOLT-1/4-20X3/4 GR8 ZINC PLTD	8	
11		235716001	WASHER-1/4 SAE HARD ZINC PLTD	8	
12		235726001	BOLT-3/8-16X3/4 GR8 HEX ZNCPLT	2	
13		235713001	WASHER-3/8 SAE HARD ZINC PLTD	2	
14		224782001	HINGE-NYLON LIFT OFF 1/4" THD	1	
14A		224781001	HINGE-NYLON LIFT OFF 1/4" THD	1	
15		293729001	PLATE - ELECTRICAL BULKHEAD	1	
16		1802006	BOLT-10-24 X 3/4 RND HD STOVE	18	
17		400001	NUT-3/16 NC HEX	18	
18		296252125	POS- E -KON DUST COVER W/LANYARD	1	
18A		296252105	BASE - PANEL MOUNT W/COVER	1	
18B		296256675	INSERT - MALE	1	
19	*	283203001	WIRING HARNES - VISE JUMPER	1	
20	*	283184001	RELAY	2	
21	*	235734001	BOLT-1/4-20X3/4 GR8 ZINC PLTD	4	
22	*	235741001	NUT - HEX - .31 - 18 - GR8 -YZ	4	
23		282531001	MODULE - DEUTSCH DT06-6S 3AMP DIODE	1	
24	*	235716001	WASHER - FLATSTRL - .25 -.28 X .63 - .06 - CZ	4	
25	*	283145001	24VDC RELAY ASSEMBLY-REMOTE MUD CONTROL	1	
26	*	283181001	RELAY - VISE CONTROL	1	

Control/Electrical-Wire Harness Assy Fig 7-1

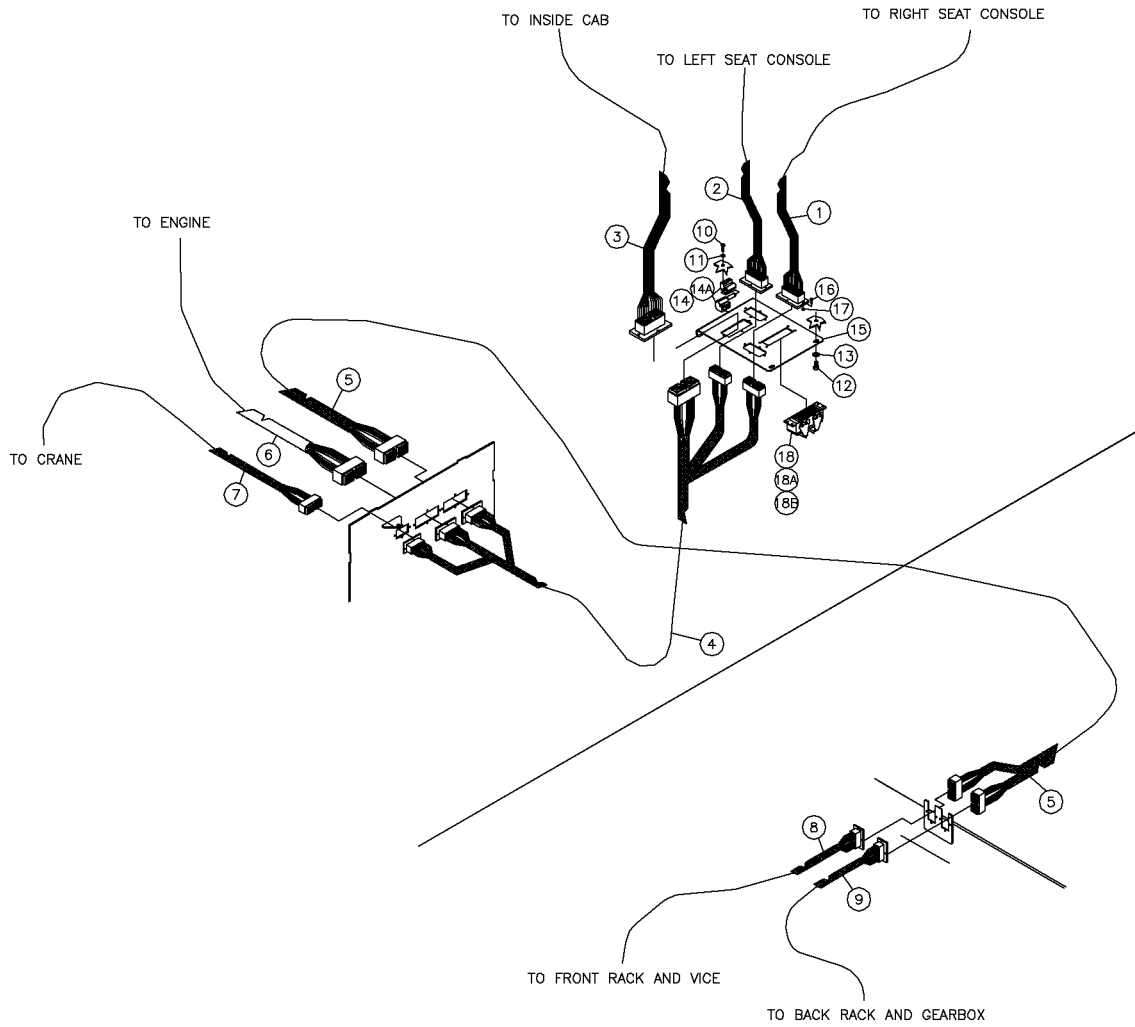

Control/Electrical-Wire Harness Assy Fig 7-1

REF. NO.	*	PART NO.	DESCRIPTION	QTY.	REMARKS
1		283113001	HARNESS - RIGHT SIDE ARMREST	1	
2		283112001	HARNESS - LEFT ARMREST	1	
3		283110001	WIRING HARNESS CAB	1	
4		283114001	WIRING HARNESS MAIN	1	
5		283122001	HARNESS RACK	1	
6		283118001	WIRING HARNESS-ENGINE	1	
7		283117001	HARNESS - CRANE	1	
8		283119001	HARNESS - FRONT RACK	1	
9		283120001	HARNESS REAR RACK	1	
10		235734001	BOLT-1/4-20X3/4 GR8 ZINC PLTD	8	
11		235716001	WASHER-1/4 SAE HARD ZINC PLTD	8	
12		235726001	BOLT-3/8-16X3/4 GR8 HEX ZNCPLT	2	
13		235713001	WASHER-3/8 SAE HARD ZINC PLTD	2	
14		224782001	HINGE-NYLON LIFT OFF 1/4" THD	1	
14A		224781001	HINGE-NYLON LIFT OFF 1/4" THD	1	
15		293729001	PLATE - ELECTRICAL BULKHEAD	1	
16		1802006	BOLT-10-24 X 3/4 RND HD STOVE	18	
17		400001	NUT-3/16 NC HEX	18	
18		296252125	POS- E -KON DUST COVER W/LANYARD	1	
18A		296252105	BASE - PANEL MOUNT W/COVER	1	
18B		296256675	INSERT - MALE	1	

Control/Electrical Box Assy Fig 7-2r01

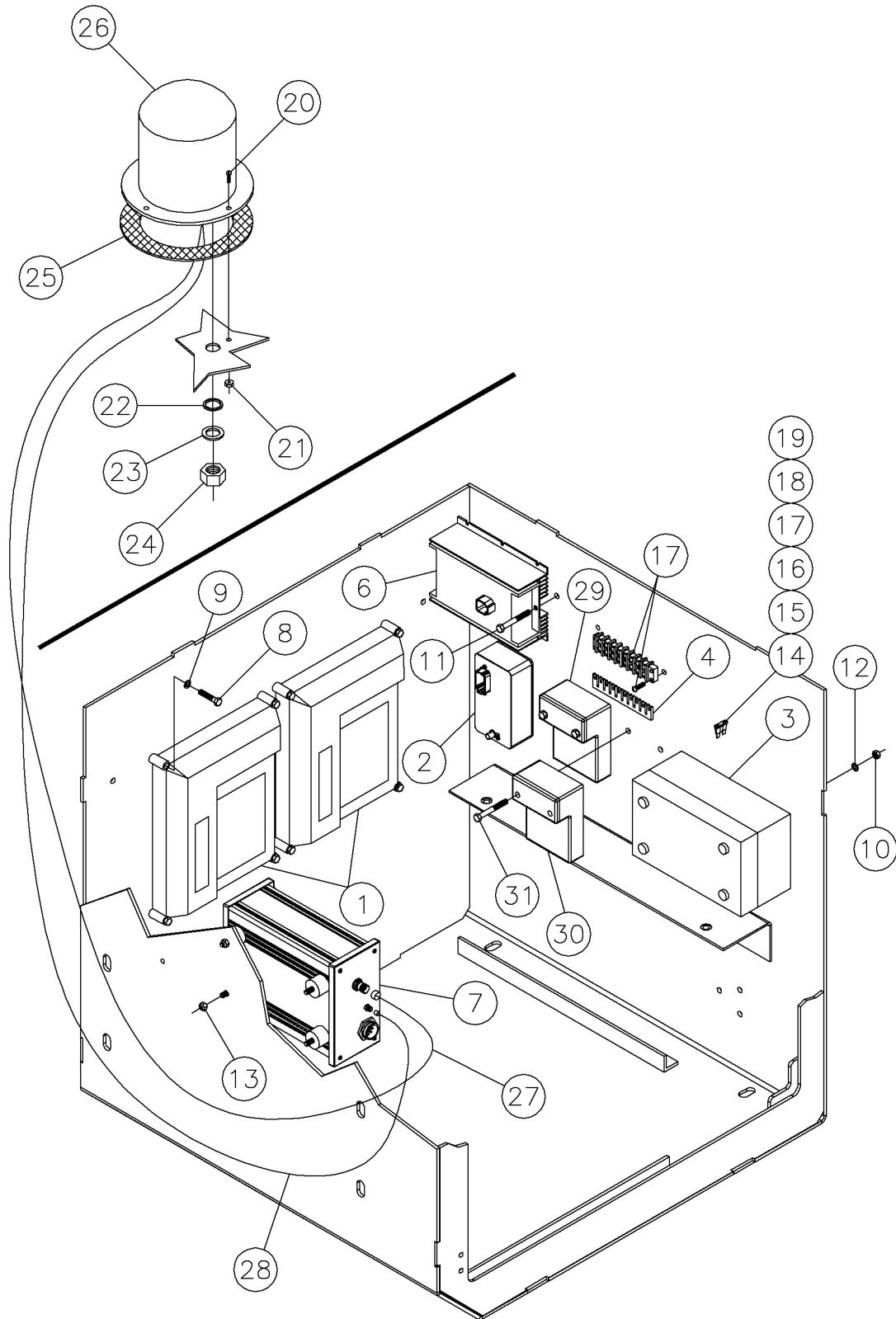

Control/Electrical Box Assy Fig 7-2r01

REF. NO.	*	PART NO.	DESCRIPTION	QTY.	REMARKS
		Revision Date	October, 2004		Update In Illustration & Parts List.
1		617615001	MICROPROCESSOR- S2X	2	
2		244588001	ZAP ALERT-CURRENT SENSE	1	
3		283043001	FUSE BOX	1	
4		236435001	TERMINAL JUMPER -267-A42-10	1	
5		79803001	10 POLE TERMINAL BLOCK	1	
6		283012001	24/12 DC-DC CONVERTER	1	
7		296250450	SITE STAR D150X300 ASSEMBLY	1	Inc Ref No's 20-27
8		235735001	BOLT-1/4-20X1 GR8 HEX ZNC PLTD	8	
9		235716001	WASHER - FLATSTRL - .25 - .28 X .63 - .06 - CZ	8	
10		235732001	NUT - HEX - .25 - 20 - GR8 - YZ	4	
11		250531001	BOLT-1/4-20 X 2 GR8 HEX Y/ZINC	2	
12		480003	WASHER-1/4 S/T LOCK	4	
13		103201001	NUT-1/4-20NC NYLON INSERT LOCK	4	
14		64037001	FUSE-5 AMP #P1171	A/R	P/M Qty Of 1 = 1 Each
15		296263330	FUSE - 7.5 AMP	A/R	P/M Qty Of 1 = 1 Each
16		122730001	FUSE-10 AMP 257010	A/R	P/M Qty Of 1 = 1 Each
17		225713119	FUSE-15 AMP	A/R	P/M Qty Of 1 = 1 Each
18		122730003	FUSE-20 AMP 257020	A/R	P/M Qty Of 1 = 1 Each
19		122730005	FUSE-30 AMP #257030	A/R	P/M Qty Of 1 = 1 Each
20		296250256	SCREW - 10 - 24X1 PLASTIC - FT - RNDHD - SLOTTED	4	
21		296250257	NUT - HEX FLGL - 10-24-PLASTIC	4	
22		296252514	SPACER- PLASTIC=.8121DX1.00ODX.093T	1	
23		296252515	WASHER-PLASTIC-.8121DX1.50ODX.93T	1	
24		296250483	NUT - 3/4 X 16 NF PLASTIC	1	
25		296252799	ANTENNA GROUND ISOLATION GASKET	1	
26		278667001	TOPHAT ANTENNA	1	
27		296250468	CABLE, GPS EXTENSION - 120"	1	
28		296250470	CABLE, VHF EXTENSION - 120"	1	
29		296266439	MICROPROCESSOR"A XCX SIDE MAIN(PROG)D150X300	1	With Crane Option Only
30		296266440	MICROPROCESSOR"B XCX SIDE MAIN(PROG)D150X300	1	With Crane Option Only
31		250644001	BOLT-1/4-20 X2 1/4 GR 8 Y/ZINC	4	With Crane Option Only

Control/Electrical Box Assy Fig 7-2

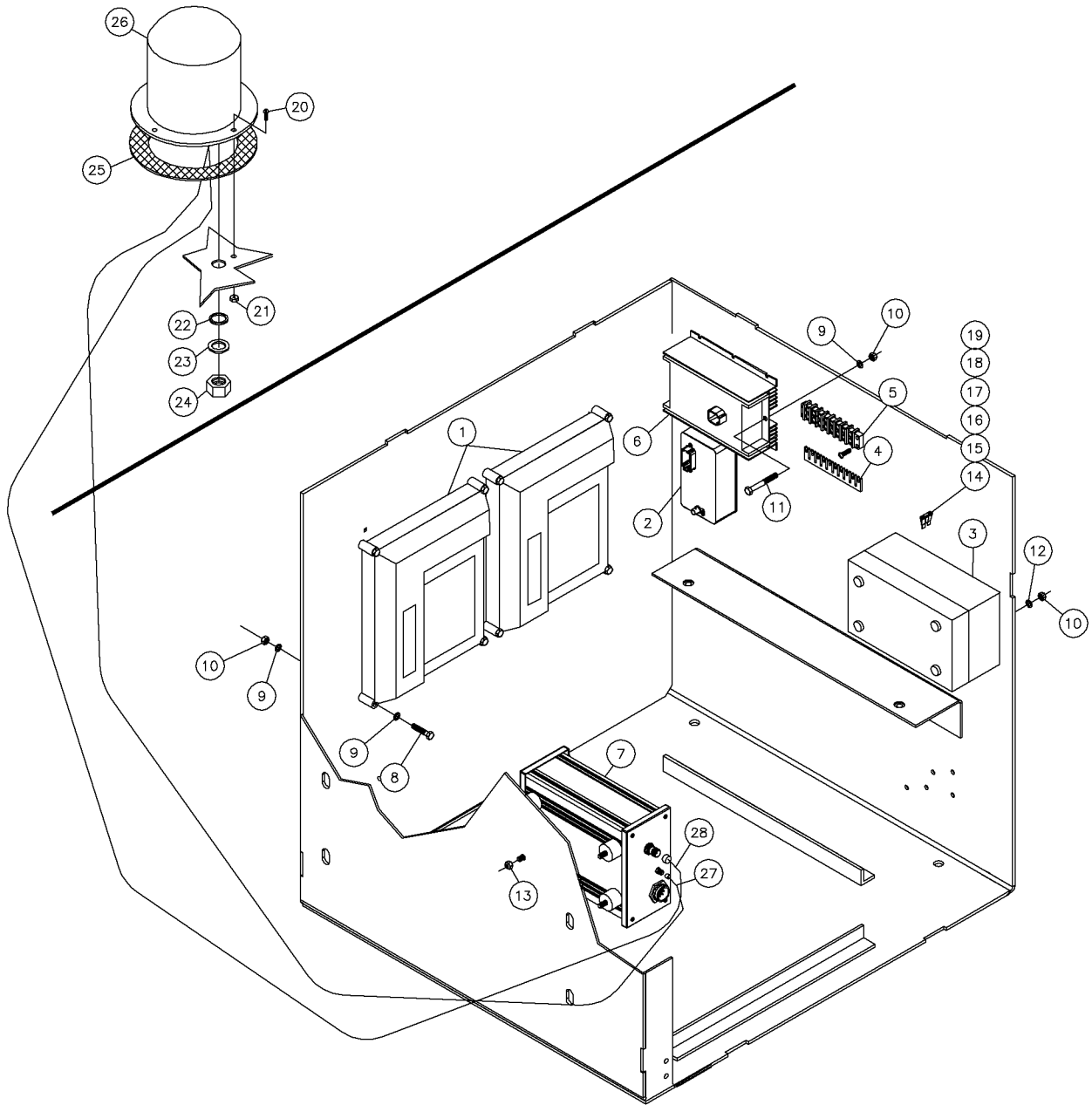

Control/Electrical Box Assy Fig 7-2

REF. NO.	*	PART NO.	DESCRIPTION	QTY.	REMARKS
1		617615001	MICROPROCESSOR- S2X	2	
2		244588001	ZAP ALERT-CURRENT SENSE	1	
3		283043001	FUSE BOX	1	
4		236435001	TERMINAL JUMPER -267-A42-10	1	
5		79803001	10 POLE TERMINAL BLOCK	1	
6		283012001	24/12 DC-DC CONVERTER	1	
7		296250450	SITE STAR D150X300 ASSEMBLY	1	Inc Ref No's 20-27
8		235735001	BOLT-1/4-20X1 GR8 HEX ZNC PLTD	8	
9		235716001	WASHER-1/4 SAE HARD ZINC PLTD	20	
10		235732001	NUT-1/4-20 GR8 ZINC PLTD	10	
11		250531001	BOLT-1/4-20 X 2 GR8 HEX Y/ZINC	2	
12		480003	WASHER-1/4 S/T LOCK	4	
13		103201001	NUT-1/4-20NC NYLON INSERT LOCK	4	
14		22474001	FUSE- 5 AMP	A/R	P/M Qty Of 1 = 1 Each
15		296263330	FUSE-7.5 AMP	A/R	P/M Qty Of 1 = 1 Each
16		122730001	FUSE-10 AMP	A/R	P/M Qty Of 1 = 1 Each
17		225713119	FUSE-15 AMP	A/R	P/M Qty Of 1 = 1 Each
18		122730003	FUSE-20 AMP	A/R	P/M Qty Of 1 = 1 Each
19		122730005	FUSE-30 AMP	A/R	P/M Qty Of 1 = 1 Each
20		296250256	SCREW - 10 - 24X1 PLASTIC - FT - RNDHD - SLOTTED	4	
21		296250257	NUT - HEX FLGL - 10-24-PLASTIC	4	
22		296252514	SPACER- PLASTIC=.8121DX1.00ODX.093T	1	
23		296252515	WASHER-PLASTIC-.8121DX1.50ODX.93T	1	
24		296250483	NUT - 3/4 X 16 NF PLASTIC	1	
25		296252799	ANTENNA GROUND ISOLATION GASKET	1	
26		278667001	TOPHAT ANTENNA	1	
27		296250468	CABLE, GPS EXTENSION - 120"	1	
28		296250470	CABLE, VHF EXTENSION - 120"	1	

Control/Electrical- Battery Assy Fig 7-3r01

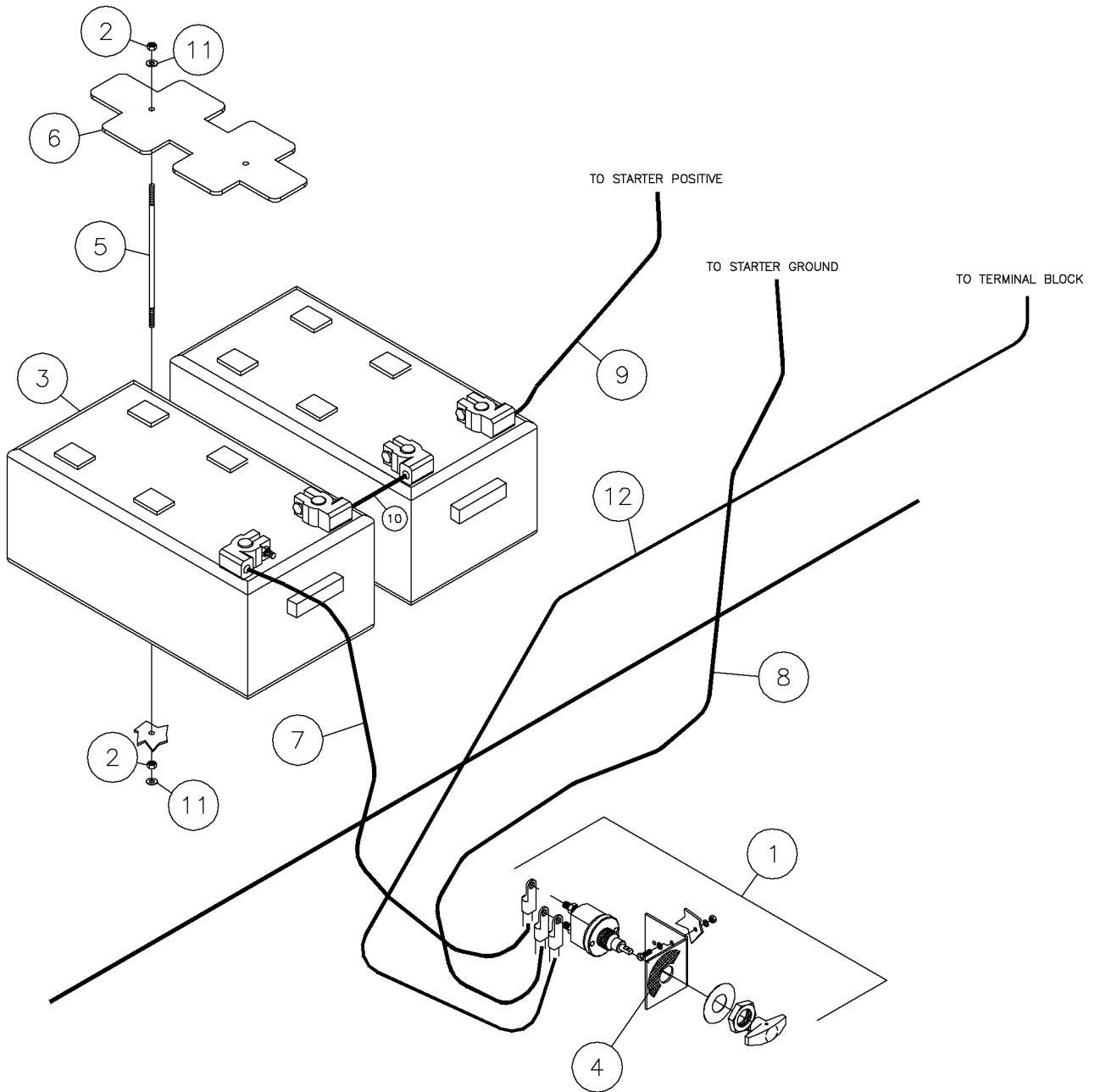

Control/Electrical- Battery Assy Fig 7-3r01

REF. NO.	*	PART NO.	DESCRIPTION	QTY.	REMARKS
		Revision Date	June, 2002		Update In Illustration & Parts List.
1		283099001	SWITCH KIT-BATTERY DISCONNECT	1	
2		235741001	NUT-5/16-18 GR8 ZINC PLTD	2	
3		837001	BATT. GROUP 8-D 1155 CCA	2	
4		700IA695	DECAL-BATTERY DISCONNECT	1	
5		296258309	ROD BATTERY	2	
6		296258313	PLATE - BATTERY HOLD DOWN	1	
7		283134001	BATTERY CABLE-BATTERY DISCONNECT	1	
8		283132001	BATTERY CABLE-NEGATIVE	1	
9		283115001	BATTERY CABLE-POSITIVE	1	
10		283133001	BATTERY CABLE-JUMPER	1	
11		235714001	WASHER-5/16 SAE HARD ZINC PLTD	1	
12	*	283156001	JUMPER CABLE - GROUND STRIP	1	

Control/Electrical- Battery Assy Fig 7-3

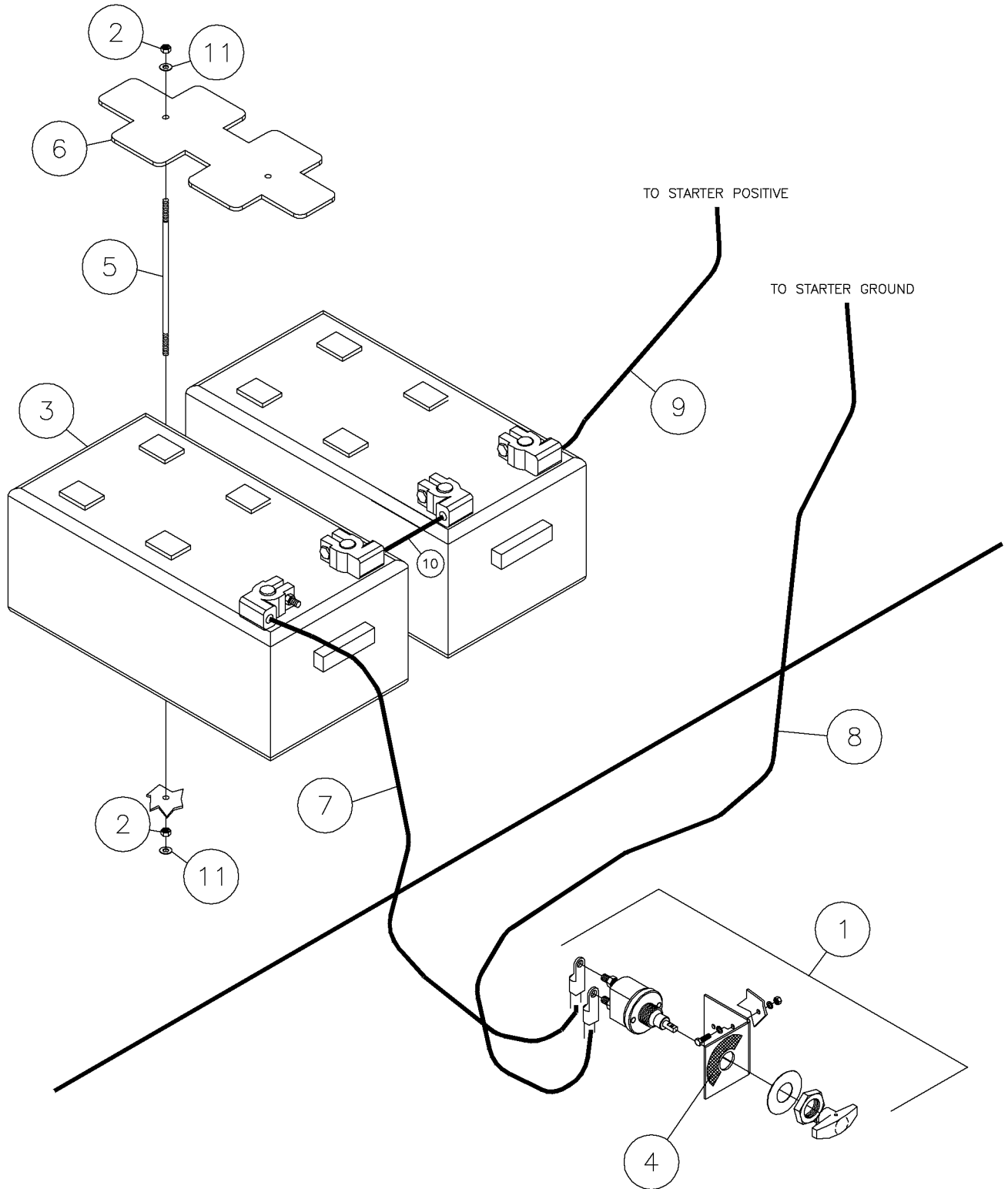

Control/Electrical- Battery Assy Fig 7-3

REF. NO.	*	PART NO.	DESCRIPTION	QTY.	REMARKS
1		283099001	SWITCH KIT-BATTERY DISCONNECT	1	
2		235741001	NUT-5/16-18 GR8 ZINC PLTD	2	
3		837001	BATT. GROUP 8-D 1155 CCA	2	
4		700IA695	DECAL-BATTERY DISCONNECT	1	
5		2962583009	SWITCH KIT-BATTERY DISCONNECT	2	
6		296258313	PLATE - BATTERY HOLD DOWN	1	
7		283134001	BATTERY CABLE-BATTERY DISCONNECT	1	
8		283132001	BATTERY CABLE-NEGATIVE	1	
9		283115001	BATTERY CABLE-POSITIVE	1	
10		283133001	BATTERY CABLE-JUMPER	1	
11		235714001	WASHER-5/16 SAE HARD ZINC PLTD	1	

Control/Electrical -Seat Assy Fig 7-4r02

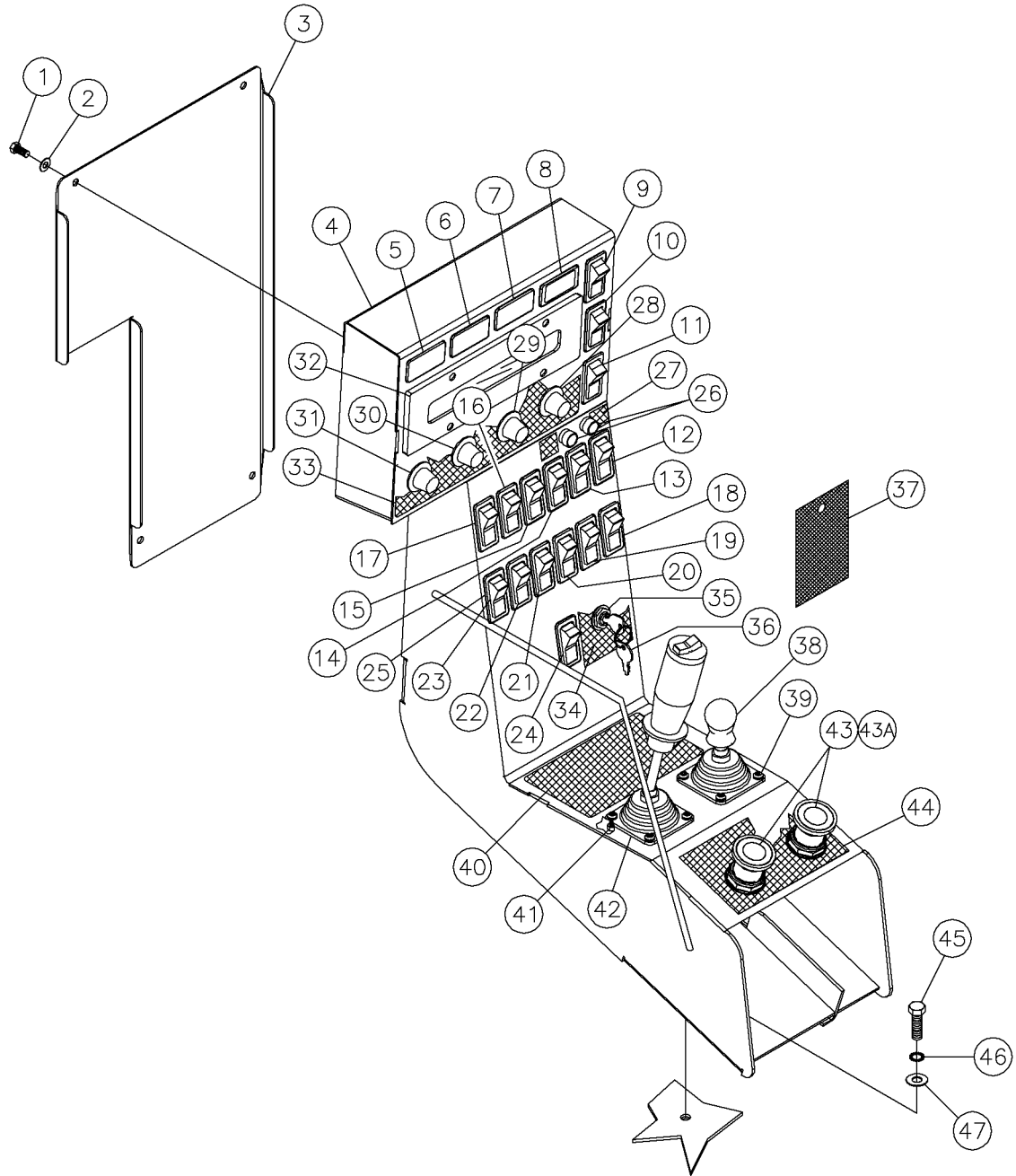

Control/Electrical -Seat Assy Fig 7-4r02

REF. NO.	*	PART NO.	DESCRIPTION	QTY.	REMARKS
		Revision Date	October, 2004		Update In Illustration & Parts List.
1		235734001	BOLT-1/4-20X3/4 GR8 ZINC PLTD	4	
2		485003	WASHER-1/4 FLAT	4	
3		296267868	PLATE - RH CONSOLE COVER	1	
4		296267864	CONSOLE - RIGHT HAND	1	
5		296275521	INDICATOR-AUTO/LOCKOUT RUN	1	
6		283094001	INDICATOR-FUEL/OIL LEVEL	1	
7		283095001	INDICATOR-OIL TEMP/OIL RETURN PRESSURE	1	
8		609566001	PLUG - ROCKER SWITCH FILLER	1	
9		283069001	ROCKER SWITCH-SCROLL	1	
10		277660001	ROCKER SWITCH-FLUID CONTROL	1	
11		283070001	ROCKER SWITCH-THRUST/STREER	1	
12		283081001	ROCKER SWITCH-LOWER VICE	1	
13		283079001	ROCKER SWITCH-UPPER VICE	1	
14		283076001	ROCKER SWITCH-UPPER VICE ROTATION	1	
15		283074001	ROCKER SWITCH-VICE SPREAD	1	
16		283072001	ROCKER SWITCH-VICE TRAVEL	1	
17		283071001	ROCKER SWITCH-CRADLE	1	
18		283154001	ROCKER - SWITCH - ENGINE SPEED INC/DEC	1	
19		283080001	ROCKER SWITCH-MAIN IDLE	1	
20		283077001	ROCKER SWITCH-PIT PUMP	1	
21		283075001	ROCKER SWITCH-MUD FLOW	1	
22		283073001	ROCKER SWITCH-MUD PUMP	1	
23		283157001	ROCKER SWITCH - WATER DUMP VALVE	1	
24		283082001	ROCKER SWITCH-HORN/ETHER	1	
25		614933001	GANG MOUNT - CENTER - EATON ROCKER SWITCH	20	(Included Ref. 5-24)
			Continued On Next Page		

Control/Electrical -Seat Assy Fig 7-4r01

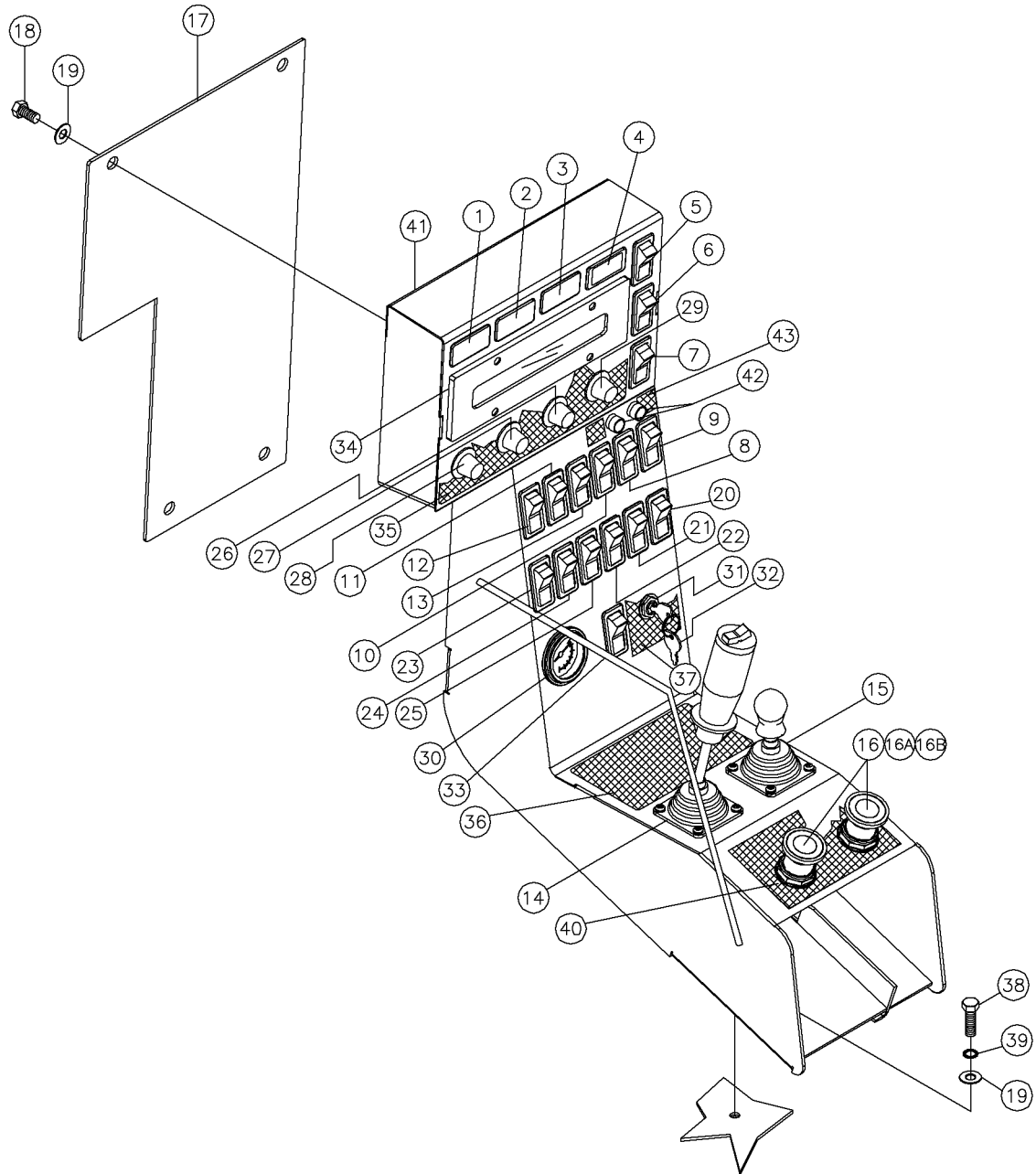

Control/Electrical -Seat Assy Fig 7-4r01

REF. NO.	*	PART NO.	DESCRIPTION	QTY.	REMARKS
		Revision Date	June, 2002		Revised Parts List
1		283090001	INDICATOR-AUTO/LOCKOUT RUN	1	
2		283094001	INDICATOR-FUEL/OIL LEVEL	1	
3		283095001	INDICATOR-OIL TEMP/OIL RETURN PRESSURE	1	
4		609566001	PLUG - ROCKER SWITCH FILLER	1	
5		283069001	ROCKER SWITCH-SCROLL	1	
6		277660001	ROCKER SWITCH-FLUID CONTROL	1	
7		283070001	ROCKER SWITCH-THRUST/STREER	1	
8		283079001	ROCKER SWITCH-UPPER VICE	1	
9		283081001	ROCKER SWITCH-LOWER VICE	1	
10		283076001	ROCKER SWITCH-UPPER VICE ROTATION	1	
11		283072001	ROCKER SWITCH-VICE TRAVEL	1	
12		283071001	ROCKER SWITCH-CRADLE	1	
13		283074001	ROCKER SWITCH-VICE SPREAD	1	
14		283107001	HANDLE - MAIN CONTROL	1	Breakdown Fig.12-26
15		283005001	HANDLE-CRANE CONTROL	1	
16		86575001	OPERATOR-PUSH/PULL W/O BUTTON	2	
16A		904563001	E-STOP LENS	2	
16B		215998001	BLOCK-N.C. CONTACT	2	
17		287998001	PLATE - COVER RIGHT ARMREST	1	
18		235726001	BOLT-3/8-16X3/4 GR8 HEX ZNCPLT	4	
19		235713001	WASHER-3/8 SAE HARD ZINC PLTD	5	
20	*	283154001	ROCKER - SWITCH - ENGINE SPEED INC/DEC	1	
			Continued On Next Page		

Control/Electrical -Seat Assy (Continued) Fig 7-4r02

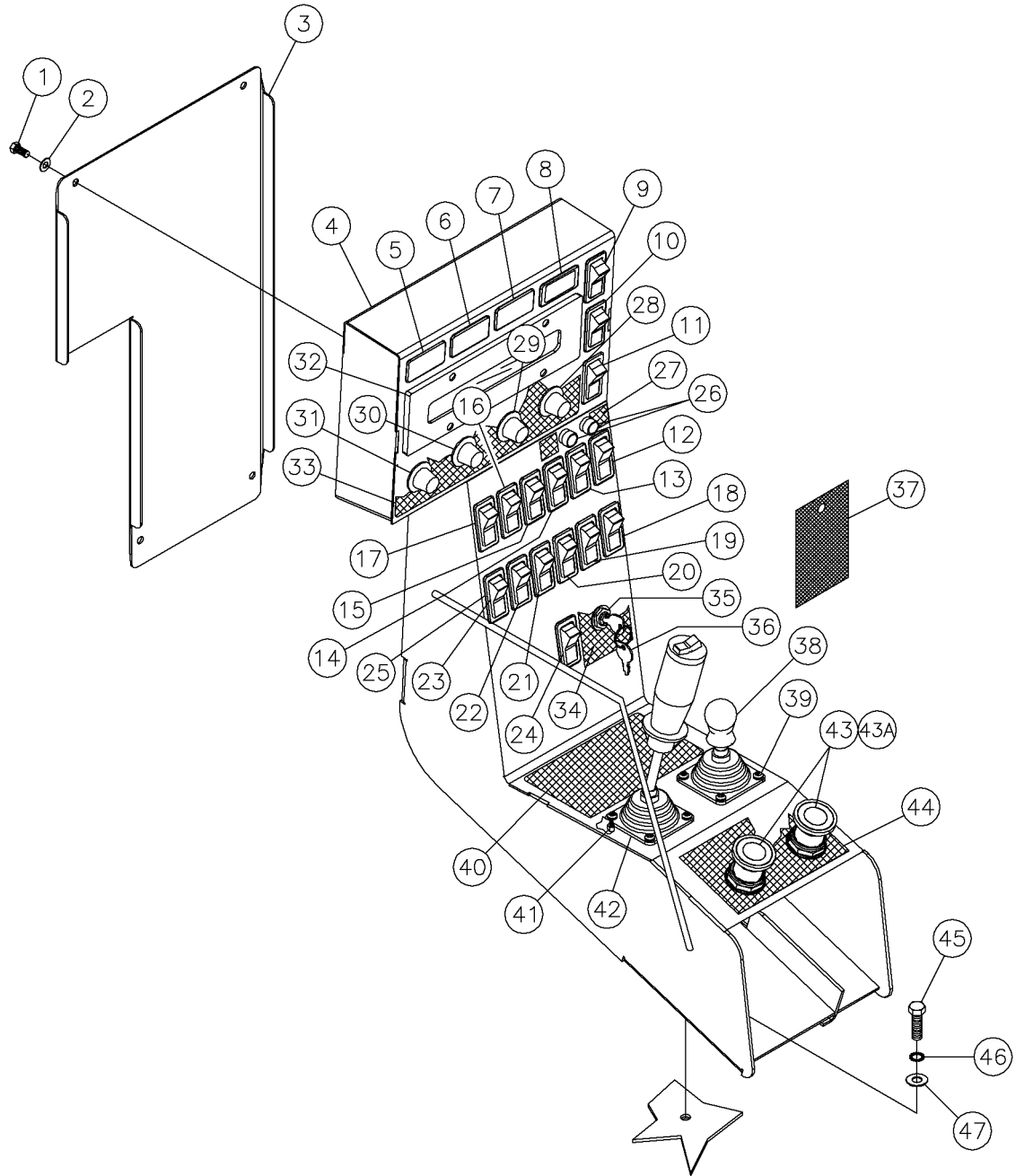

Control/Electrical -Seat Assy (Continued) Fig 7-4r02

REF. NO.	*	PART NO.	DESCRIPTION	QTY.	REMARKS
		Revision Date	October, 2004		Update In Illustration & Parts List.
26		260766001	SWITCH-MOM BUTTON NO	2	
27		700IB871	DECAL - VISE BUTTON	1	
28		283144001	ROTARY SWITCH ASSEMBLY - DRILL HEAD SELECTOR	1	
29		283143001	POTENTIOMETER ASSEMBLY- PULLBACK DISTANCE	1	
30		283142001	POTENTIOMETER ASSEMBLY- CUTTING DURATION	1	
31		283141001	POTENTIOMETER ASSEMBLY STEERING DIRECTION	1	
32		283053001	DISPLAY-MAIN CONTROLLER	1	
33		700IB409	DECAL - AUTO STEERING	1	
34		700IB408	DECAL - IGNITION	1	
35		285597001	SWITCH - IGNITION	1	
36		285597002	KEYS - IGNITION SWITCH (MATCHED PAIR)	1	
37		296264000	REMOTE ENGINE/HYDRAULIC LOCKOUT CARD	1	
38		283005001	HANDLE-CRANE CONTROL	1	
39		10530006	SCREW-#8-32X3/4 SLOT RD.HD.	8	
40		700IB612	DECAL - RIGHT JOYSTICK	1	
41		399001	NUT-8-32 HEX	8	
42		283107001	HANDLE - MAIN CONTROL	1	(Breakdown Fig. 12-26)
43		296259684	BUTTON - RED PUSH/PULL	1	
43A		180005209	ADAPTER WASHER 22MM TO 30MM	1	
44		700IB407	DECAL - EMERGENCY STOP	1	
45		235736001	BOLT-3/8-16X1 1/4 ZINC PLTD	1	
46		481011	WASHER - 3/8 EXTERNAL STAR	1	
47		235713001	WASHER - FLATSTRL - .38 - .41 X .81 - .06-YA-A325	1	

Control/Electrical -Seat Assy (Continued) Fig 7-4r01

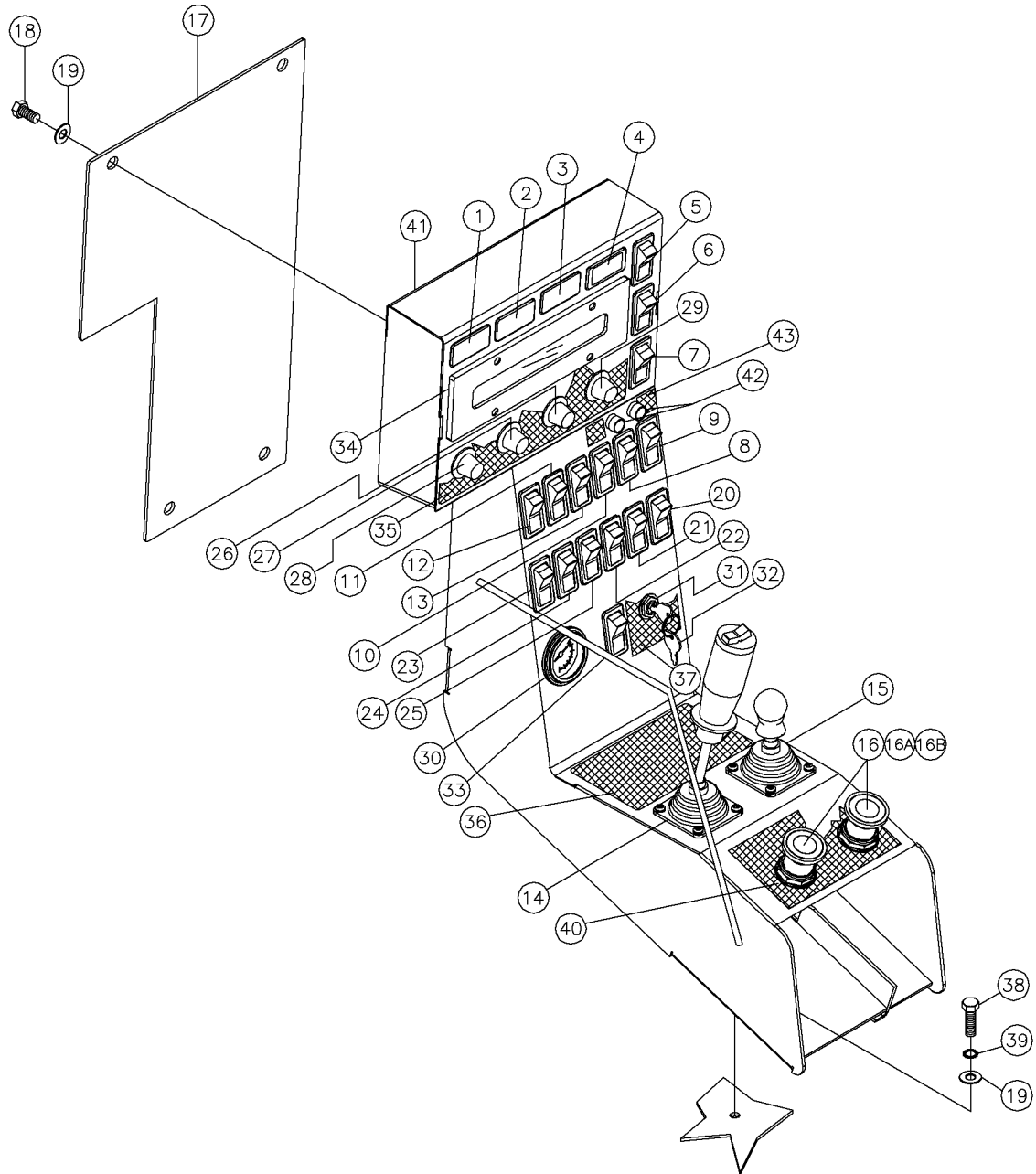

Control/Electrical -Seat Assy (Continued) Fig 7-4r01

REF. NO.	*	PART NO.	DESCRIPTION	QTY.	REMARKS
		Revision Date	June, 2002		Revised Parts List
21		283080001	ROCKER SWITCH-MAIN IDLE	1	
22		283077001	ROCKER SWITCH-PIT PUMP	1	
23		283157001	ROCKER SWITCH - WATER DUMP VALVEROCKER SWITCH-	1	
24		283073001	ROCKER SWITCH-MUD PUMP	1	
25		283075001	ROCKER SWITCH-MUD FLOW	1	
26		283143001	POTENTIOMETER ASSEMBLY-PULLBACK DISTANCE	1	
27		283142001	POTENTIOMETER ASSEMBLY- CUTTING DURATION	1	
28		283141001	POTENTIOMETER ASSEMBLY STEERING DIRECTION	1	
29		283144001	ROTARY SWITCH ASSEMBLY - DRILL HEAD SELECTOR	1	
30		600095001	GAUGE-FUEL #107094	1	
31		285597001	SWITCH - IGNITION	1	
32		285597002	KEYS - IGNITION SWITCH (MATCHED PAIR)	1	
33	*	283082001	ROCKER SWITCH-HORN/ETHER	1	
34		283053001	DISPLAY-MAIN CONTROLLER	1	
35		700IB409	DECAL - AUTO STEERING	1	
36		700IB612	DECAL - RIGHT JOYSTICK	1	
37		700IB408	DECAL - IGNITION	1	
38		235736001	BOLT-3/8-16X1 1/4 ZINC PLTD	1	
39		481011	WASHER - 3/8 EXTERNAL STAR	1	
40		700IB407	DECAL - EMERGENCY STOP	1	
41		296000001	WELDMENT RIGHT SIDE ARMREST CONSOLE	1	
42		260766001	SWITCH-MOM BUTTON NO	2	
43		700IB871	DECAL-VISE BUTTON	2	

Control/Electrical -Seat Assy Fig 7-4

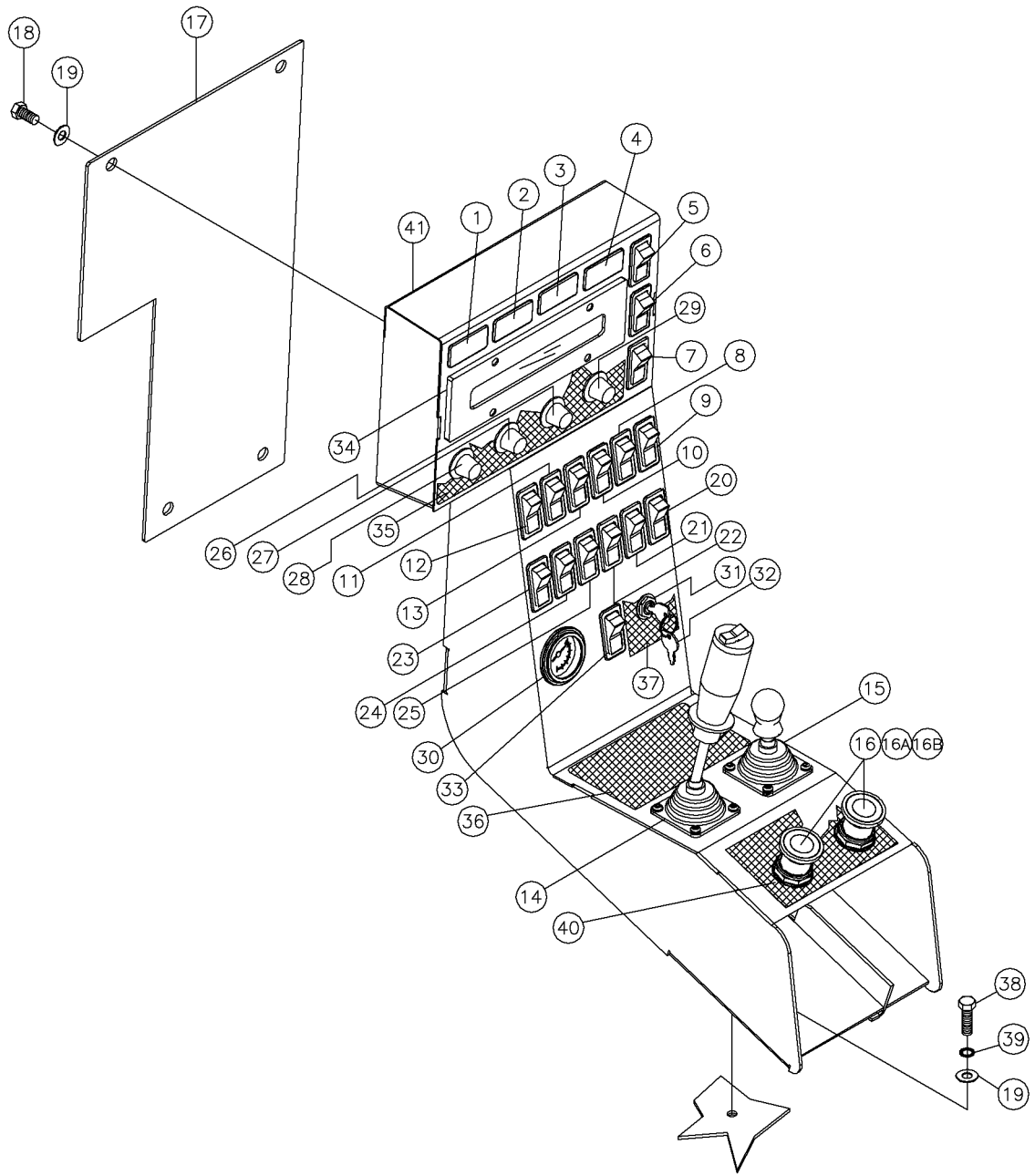

Control/Electrical -Seat Assy Fig 7-4

REF. NO.	*	PART NO.	DESCRIPTION	QTY.	REMARKS
1		283090001	INDICATOR-AUTO/LOCKOUT RUN	1	
2		283096001	INDICATOR - LOCKOUT TEST	1	
3		283094001	INDICATOR-FUEL/OIL LEVEL	1	
4		283095001	INDICATOR-OIL TEMP/OIL RETURN PRESSURE	1	
5		283069001	ROCKER SWITCH-SCROLL	1	
6		277660001	ROCKER SWITCH-FLUID CONTROL	1	
7		283070001	ROCKER SWITCH-THRUST/STREER	1	
8		283079001	ROCKER SWITCH-UPPER VICE	1	
9		283081001	ROCKER SWITCH-LOWER VICE	1	
10		283076001	ROCKER SWITCH-UPPER VICE ROTATION	1	
11		283072001	ROCKER SWITCH-VICE TRAVEL	1	
12		283071001	ROCKER SWITCH-CRADLE	1	
13		283074001	ROCKER SWITCH-VICE SPREAD	1	
14		283107001	HANDLE - MAIN CONTROL	1	Breakdown On Fig12-26
15		283005001	HANDLE-CRANE CONTROL	1	
16		86575001	OPERATOR-PUSH/PULL W/O BUTTON	2	
16A		904563001	E-STOP LENS	2	
16B		215998001	BLOCK-N.C. CONTACT	2	
17		287998001	PLATE - COVER RIGHT ARMREST	1	
18		235726001	BOLT-3/8-16X3/4 GR8 HEX ZNCPLT	4	
19		235713001	WASHER-3/8 SAE HARD ZINC PLTD	5	
20		277700001	ROCKER SWITCH - ENGINE THROTTLE	1	
21		283080001	ROCKER SWITCH-MAIN IDLE	1	
22		283077001	ROCKER SWITCH-PIT PUMP	1	
23		283147001	G/B BRAKE SW,SPST,ON-ON	1	
24		283073001	ROCKER SWITCH-MUD PUMP	1	
25		283075001	ROCKER SWITCH-MUD FLOW	1	
26		283143001	POTENTIOMETER ASSEMBLY-PULLBACK DISTANCE	1	
27		283142001	POTENTIOMETER ASSEMBLY- CUTTING DURATION	1	
28		283141001	POTENTIOMETER ASSEMBLY STEERING DIRECTION	1	
29		283144001	ROTARY SWITCH ASSEMBLY - DRILL HEAD SELECTOR	1	
30		600095001	GAUGE-FUEL #107094	1	
31		285597001	SWITCH - IGNITION	1	
32		285597002	KEYS - IGNITION SWITCH (MATCHED PAIR)	1	
33		283075001	ROCKER SWITCH-MUD FLOW	1	
34		283053001	DISPLAY-MAIN CONTROLLER	1	
35		700IB409	DECAL - AUTO STEERING	1	
36		700IB612	DECAL - RIGHT JOYSTICK	1	
37		700IB408	DECAL - IGNITION	1	
38		235736001	BOLT-3/8-16X1 1/4 ZINC PLTD	1	
39		481011	WASHER - 3/8 EXTERNAL STAR	1	
40		700IB407	DECAL - EMERGENCY STOP	1	
41		296000001	WELDMENT RIGHT SIDE ARMREST CONSOLE	1	

Console/Electrical- Seat Assy Fig 7-5r02

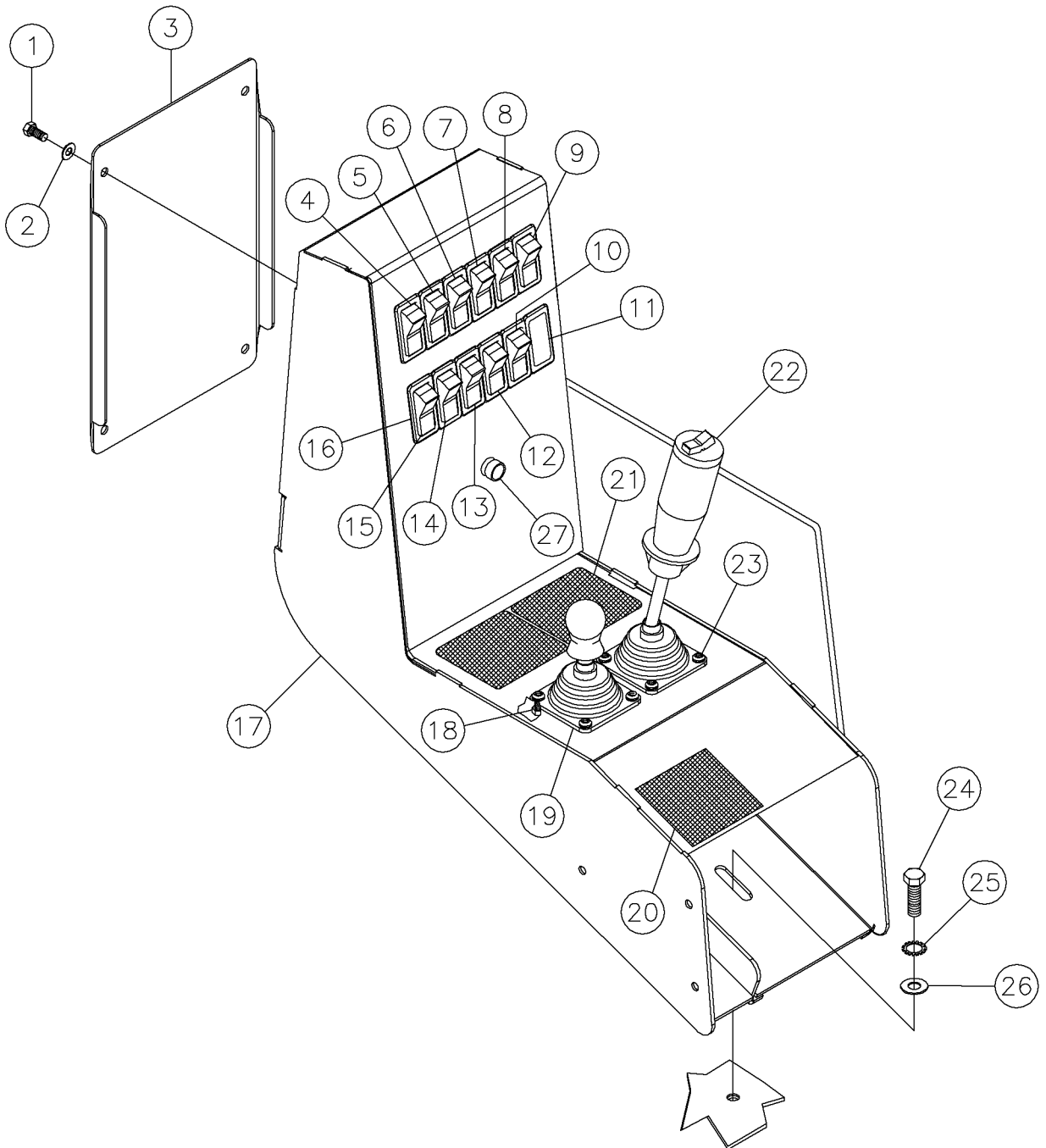

Console/Electrical- Seat Assy Fig 7-5r02

REF. NO.	*	PART NO.	DESCRIPTION	QTY.	REMARKS
		Revision Date	October, 2004		Update In Illustration & Parts List.
1		235734001	BOLT-1/4-20X3/4 GR8 ZINC PLTD	4	
2		485003	WASHER-1/4 FLAT	4	
3		296267873	PLATE - LH CONSOLE COVER	1	
4		283078001	ROCKER SWITCH-RACK SPEED	1	
5		283092001	ROCKER SWITCH-G/B SPEED	1	
6		283147001	G/B BRAKE SW,SPST,ON-ON	1	
7		283089001	ROCKER SWITCH-CATWALK	1	
8		283088001	ROCKER SWITCH-PARK BRAKE	1	
9		283093001	ROCKER SWITCH-DRILL/TRANSPORT	1	
10		277647001	SWITCH -RACK ANGLE ROCKER	1	
11		609566001	PLUG - ROCKER SWITCH FILLER	1	
12		283107001	HANDLE - MAIN CONTROL	1	
13		283086001	ROCKER SWITCH-CRANE BASE LIFT		
14		283085001	ROCKER SWITCH-CRANK BASE LOCK	1	
15		283101001	ROCKER SWITCH-WINCH SPEED	1	
16		614933001	GANG MOUNT - CENTER - EATON ROCKER SWITCH	12	Included Ref. 4-15
17		296267869	CONSOLE - LEFT HAND	1	
18		399001	NUT-8-32 HEX	8	
19		283005001	HANDLE-CRANE CONTROL	1	
20		2326940	DECAL-NOTICE TO OWNERS	1	
21		700IB613	DECAL - LEFT JOYSTICK	1	
22		283107001	HANDLE - MAIN CONTROL	1	
23		10530006	SCREW-#8-32X3/4 SLOT RD.HD.	8	
24		235736001	BOLT-3/8-16X1 1/4 ZINC PLTD	1	
25		481011	WASHER - 3/8 EXTERNAL STAR	1	
26		235713001	WASHER - FLATSTRL - .38 - .41 X .81 - .06-YA-A325	1	
27		260766001	SWITCH-MOM BUTTON NO	1	

Console/Electrical- Seat Assy Fig 7-5r01

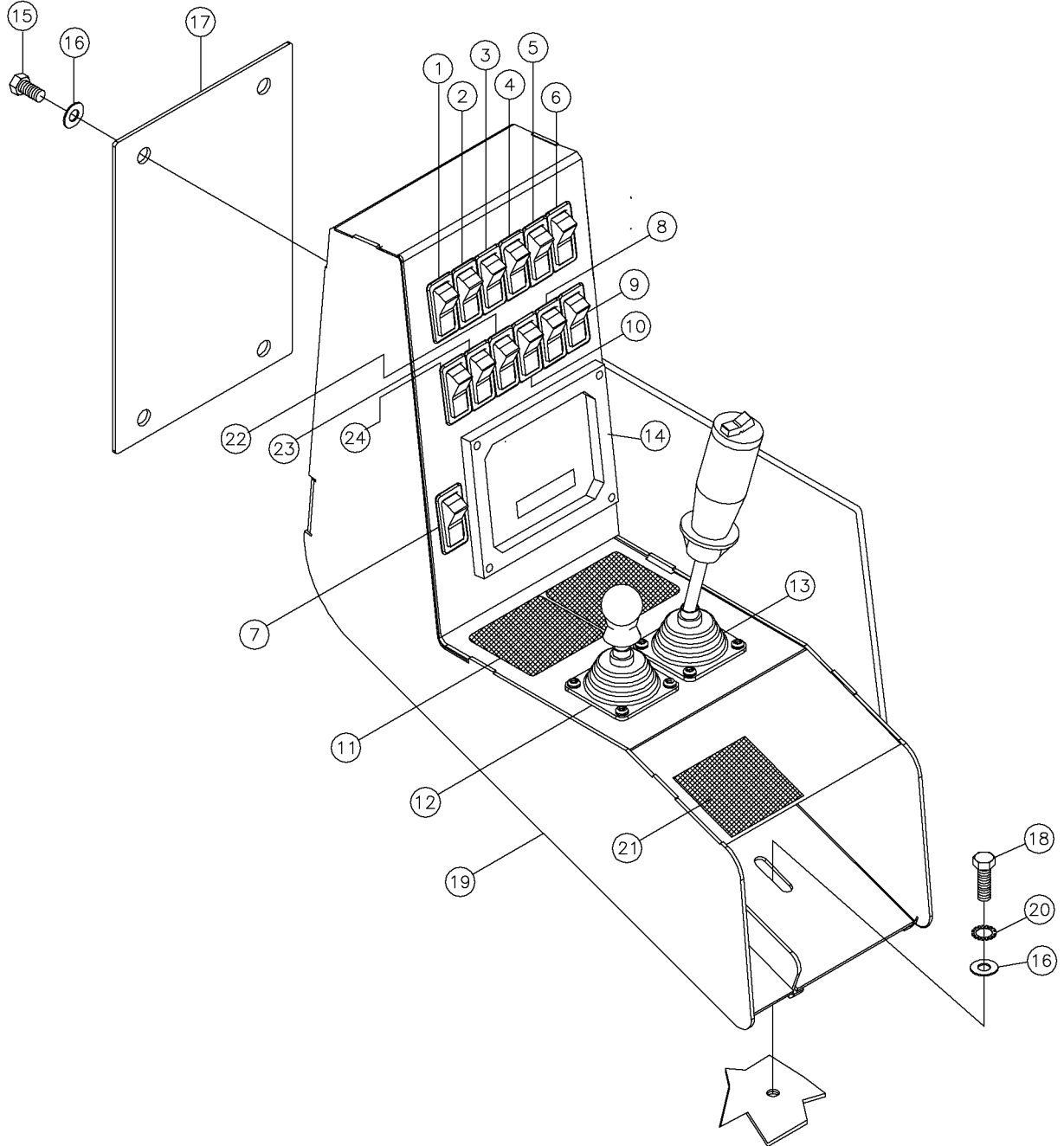

Console/Electrical- Seat Assy Fig 7-5r01

REF. NO.	*	PART NO.	DESCRIPTION	QTY.	REMARKS
		Revision Date	June, 2002		Revised Drawing
1		283078001	ROCKER SWITCH-RACK SPEED	1	
2		283092001	ROCKER SWITCH-G/B SPEED	1	
3		277647001	SWITCH -RACK ANGLE ROCKER	1	
4		283089001	ROCKER SWITCH-CATWALK	1	
5		283088001	ROCKER SWITCH-PARK BRAKE	1	
6		283093001	ROCKER SWITCH-DRILL/TRANSPORT	1	
7		283069001	ROCKER SWITCH-SCROLL	1	
8		609566001	PLUG - ROCKER SWITCH FILLER	4	
9		283096001	INDICATOR - LOCKOUT TEST	1	
10		283130001	ROCKER SWITCH-CRANE MAIN POWER	1	
11		700IB613	DECAL - LEFT JOYSTICK	1	
12		283005001	HANDLE-CRANE CONTROL	1	
13		283107001	HANDLE - MAIN CONTROL	1	Breakdown On Fig 12-26
14		283155001	EMS MAIN DISPLAY - CAT ENGINE	1	
15		235726001	BOLT-3/8-16X3/4 GR8 HEX ZNCPLT	4	
16		235713001	WASHER-3/8 SAE HARD ZINC PLTD	5	
17		287992001	PLATE - COVER LEFT ARMREST	1	
18		235736001	BOLT-3/8-16X1 1/4 ZINC PLTD	1	
19		287997001	WELDMENT LEFT SIDE ARMREST CONSOLE	1	
20		481011	WASHER - 3/8 EXTERNAL STAR	1	
21		2326940	DECAL-NOTICE TO OWNERS	1	
22		283086001	ROCKER SWITCH-CRANE BASE LIFT	1	
23		283085001	ROCKER SWITCH-CRANK BASE LOCK	1	
24		283101001	ROCKER SWITCH-WINCH SPEED	1	

Console/Electrical- Seat Assy Fig 7-5

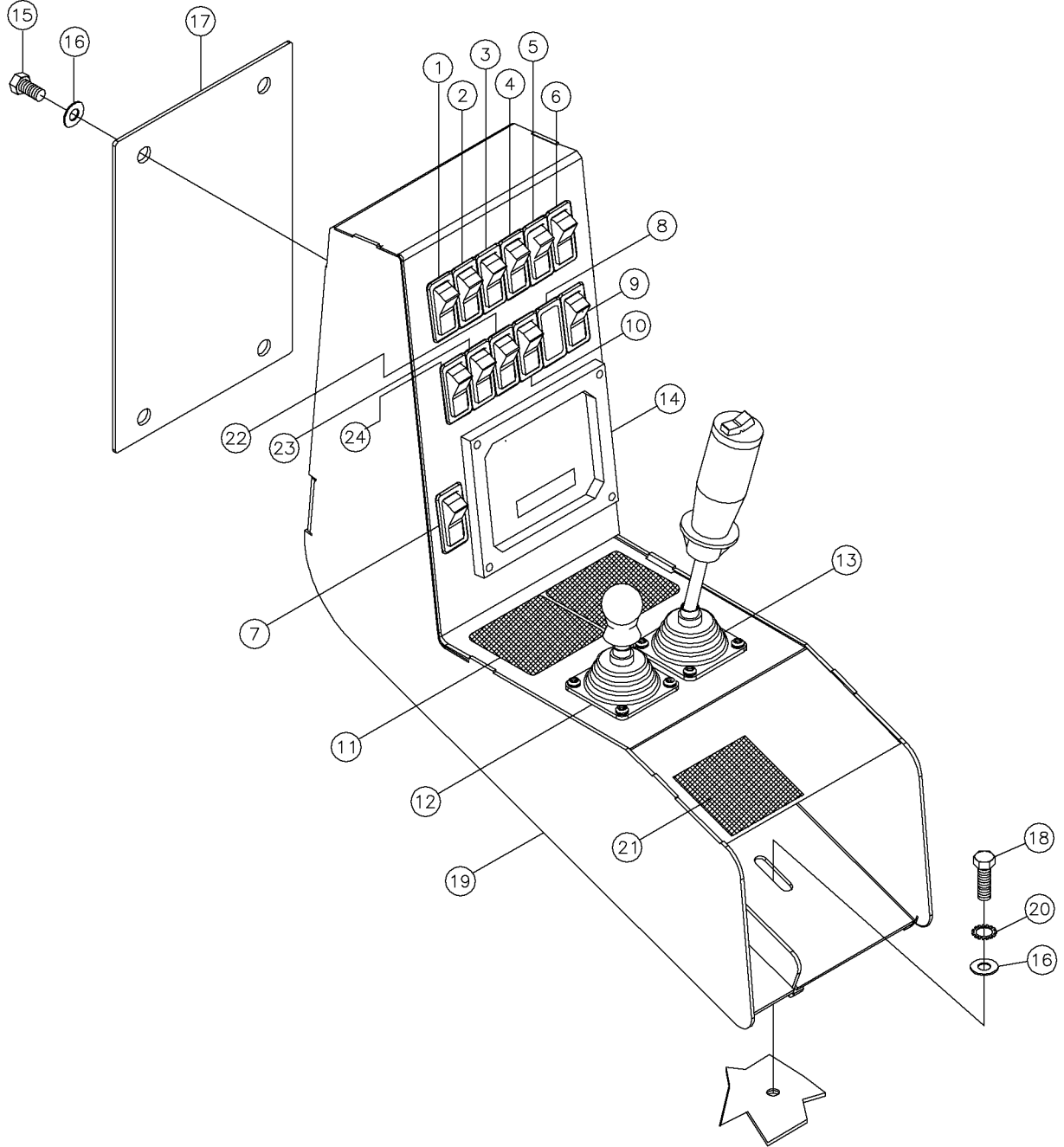

Console/Electrical- Seat Assy Fig 7-5

REF. NO.	*	PART NO.	DESCRIPTION	QTY.	REMARKS
1		283078001	ROCKER SWITCH-RACK SPEED	1	
2		283092001	ROCKER SWITCH-G/B SPEED	1	
3		277647001	SWITCH -RACK ANGLE ROCKER	1	
4		283089001	ROCKER SWITCH-CATWALK	1	
5		283088001	ROCKER SWITCH-PARK BRAKE	1	
6		283093001	ROCKER SWITCH-DRILL/TRANSPORT	1	
7		283069001	ROCKER SWITCH-SCROLL	1	
8		609566001	PLUG - ROCKER SWITCH FILLER	4	
9		283096001	INDICATOR - LOCKOUT TEST	1	
10		283130001	ROCKER SWITCH-CRANE MAIN POWER	1	
11		700IB613	DECAL - LEFT JOYSTICK	1	
12		283005001	HANDLE-CRANE CONTROL	1	
13		283107001	HANDLE - MAIN CONTROL	1	Breakdown On Fig 12-26
14		283155001	EMS MAIN DISPLAY - CAT ENGINE	1	
15		235726001	BOLT-3/8-16X3/4 GR8 HEX ZNCPLT	4	
16		235713001	WASHER-3/8 SAE HARD ZINC PLTD	5	
17		287992001	PLATE - COVER LEFT ARMREST	1	
18		235736001	BOLT-3/8-16X1 1/4 ZINC PLTD	1	
19		287997001	WELDMENT LEFT SIDE ARMREST CONSOLE	1	
20		481011	WASHER - 3/8 EXTERNAL STAR	1	
21		2326940	DECAL-NOTICE TO OWNERS	1	
22		283086001	ROCKER SWITCH-CRANE BASE LIFT	1	
23		283085001	ROCKER SWITCH-CRANK BASE LOCK	1	
24		283101001	ROCKER SWITCH-WINCH SPEED	1	

Control/Electrical-Dome Light Assy Fig 7-6

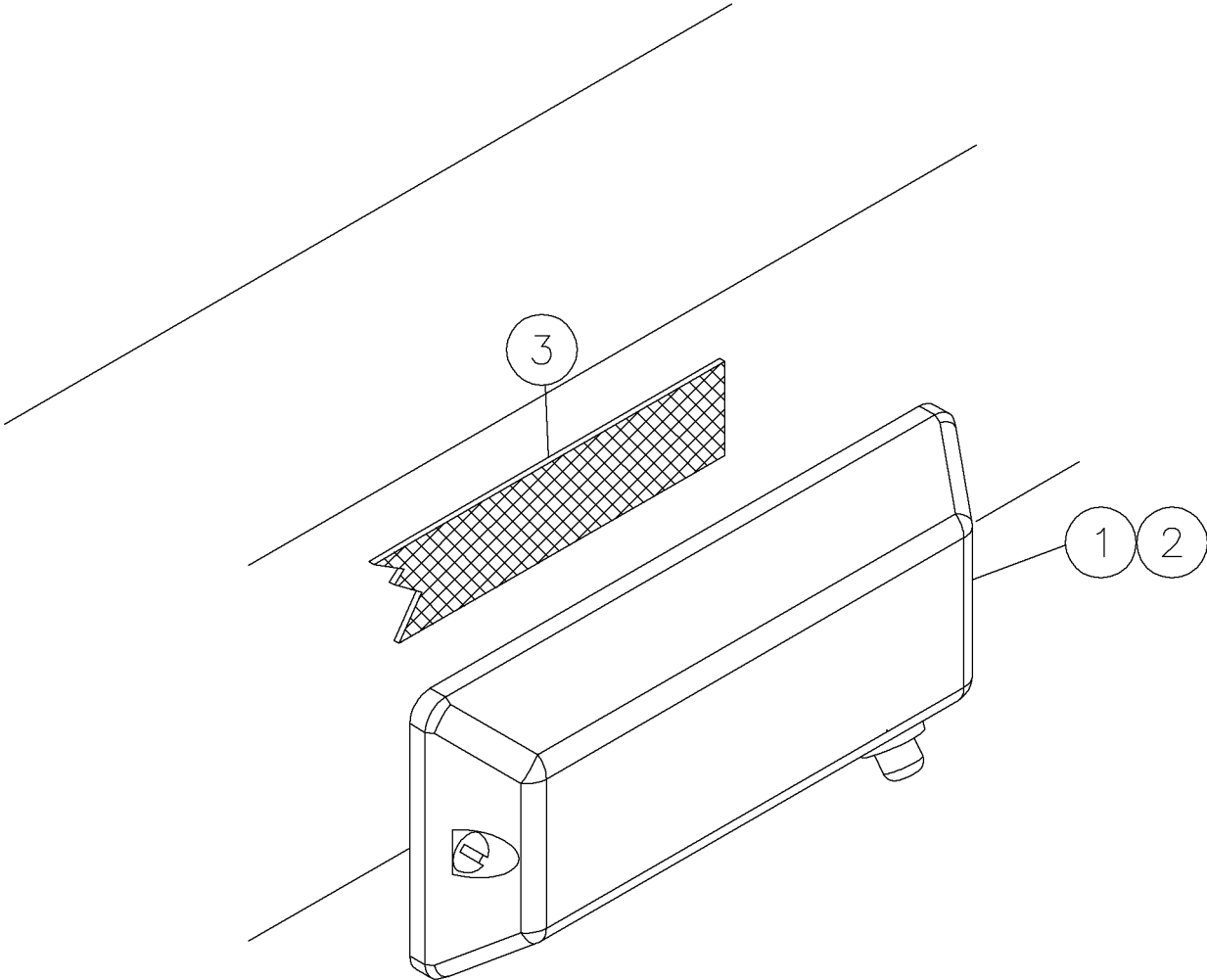

Control/Electrical-Dome Light Assy Fig 7-6

REF. NO.	*	PART NO.	DESCRIPTION	QTY.	REMARKS
1		283066001	DOME LIGHT	2	Inc One Of Ref No 2
2		296253494	BULB - FESTOON 24V 15 WATT	1	Pack Of Ten
3		283148001	ACRYLIC - ADHESIVE TAPE BACK	A/R	P/N Qty Of 1 = 1 Each

Control/Electrical-Work Light Assy Fig 7-7

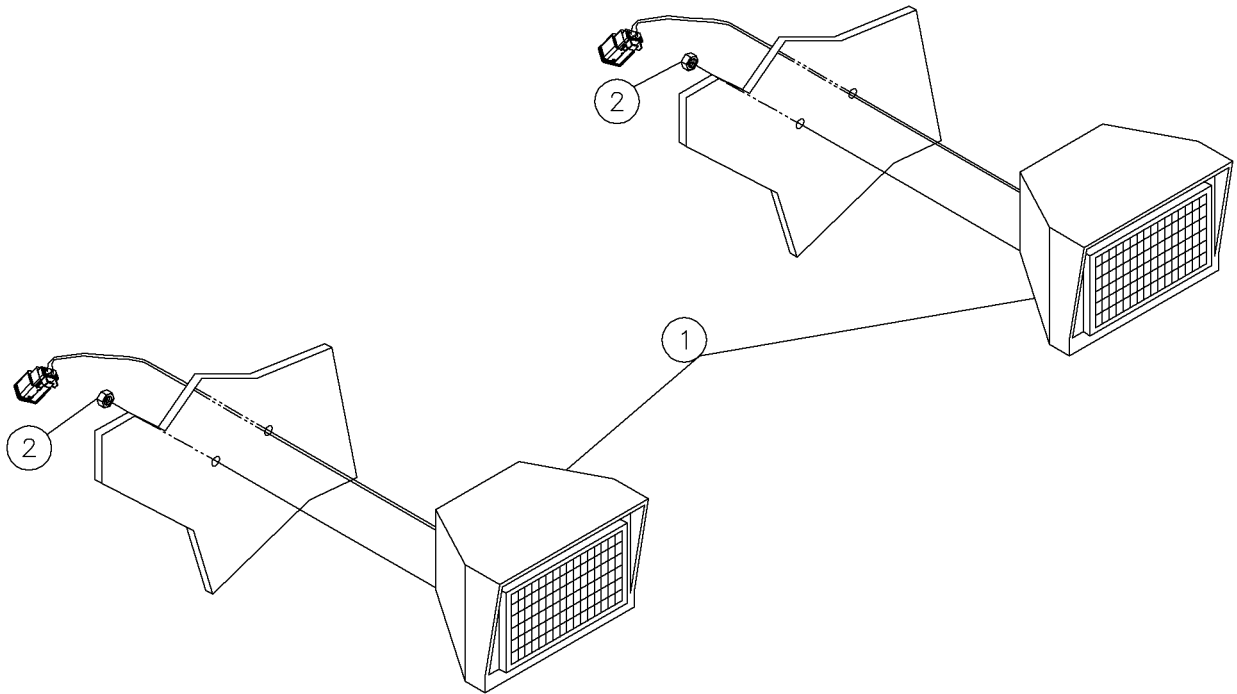

Control/Electrical-Work Light Assy Fig 7-7

REF. NO.	*	PART NO.	DESCRIPTION	QTY.	REMARKS
1		283065001	WORK LIGHT	4	
2		235741001	NUT-5/16-18 GR8 ZINC PLTD	4	

Control/Electrical Communication Panel Assy Fig 7-8r01

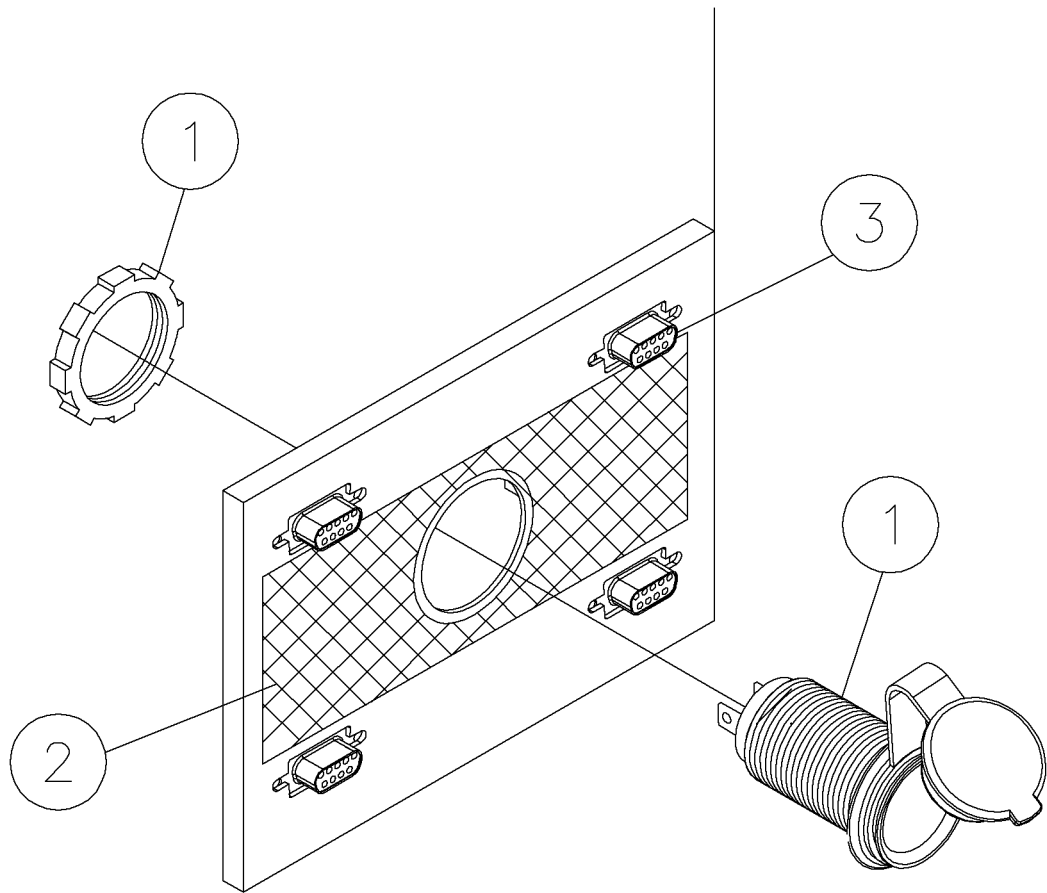

Control/Electrical Communication Panel Assy Fig 7-8r01

REF. NO.	*	PART NO.	DESCRIPTION	QTY.	REMARKS
		Revision Date	October, 2004		Update In Illustration & Parts List.
1		154677001	OUTLET - 12 VOLT	1	
2		700IB410	DECAL - POWER POINT	1	
3		283149001	FEMALE SCREWLOCK KIT	1	

Control/Electrical Communication Panel Assy Fig 7-8

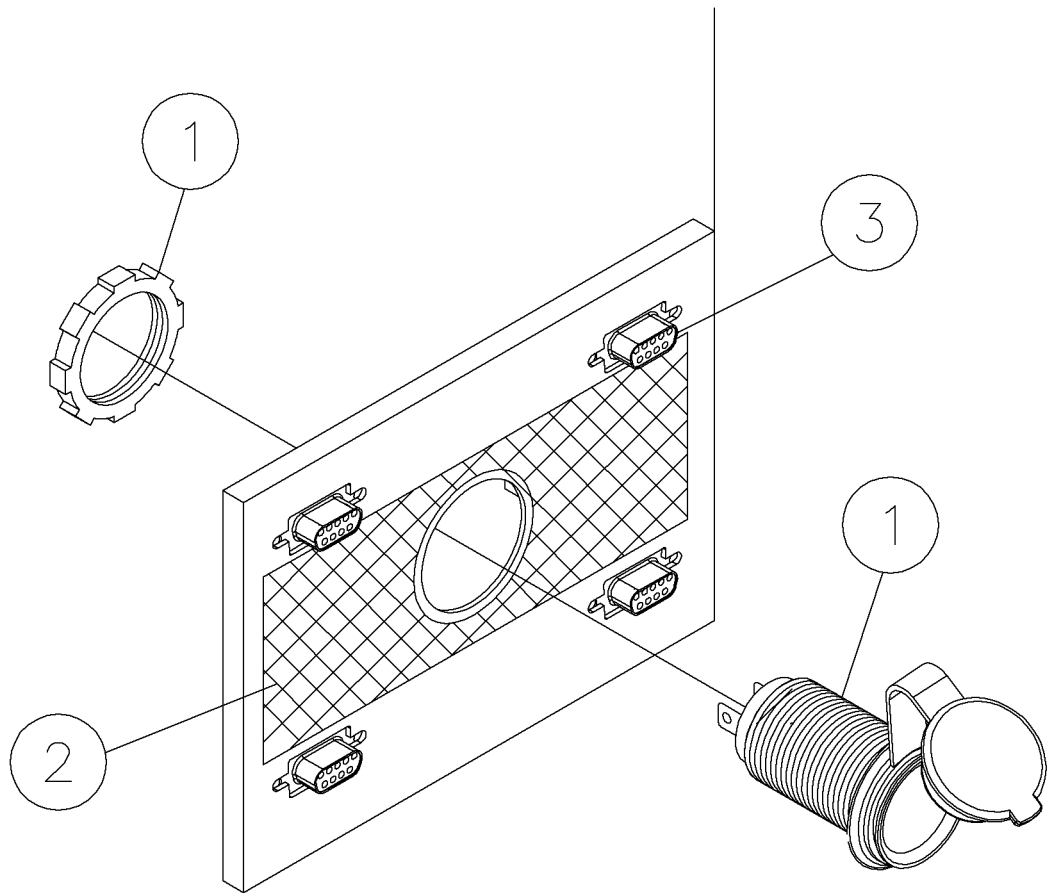

Control/Electrical Communication Panel Assy Fig 7-8

REF. NO.	*	PART NO.	DESCRIPTION	QTY.	REMARKS
1		285604001	OUTLET - 12 VOLT	1	
2		700IB410	DECAL - POWER POINT	1	
3		283149001	FEMALE SCREWLOCK KIT	1	

Control/Electrical-Back-Up/High Pitch/Zap Alert Horn Assy Fig 7-9

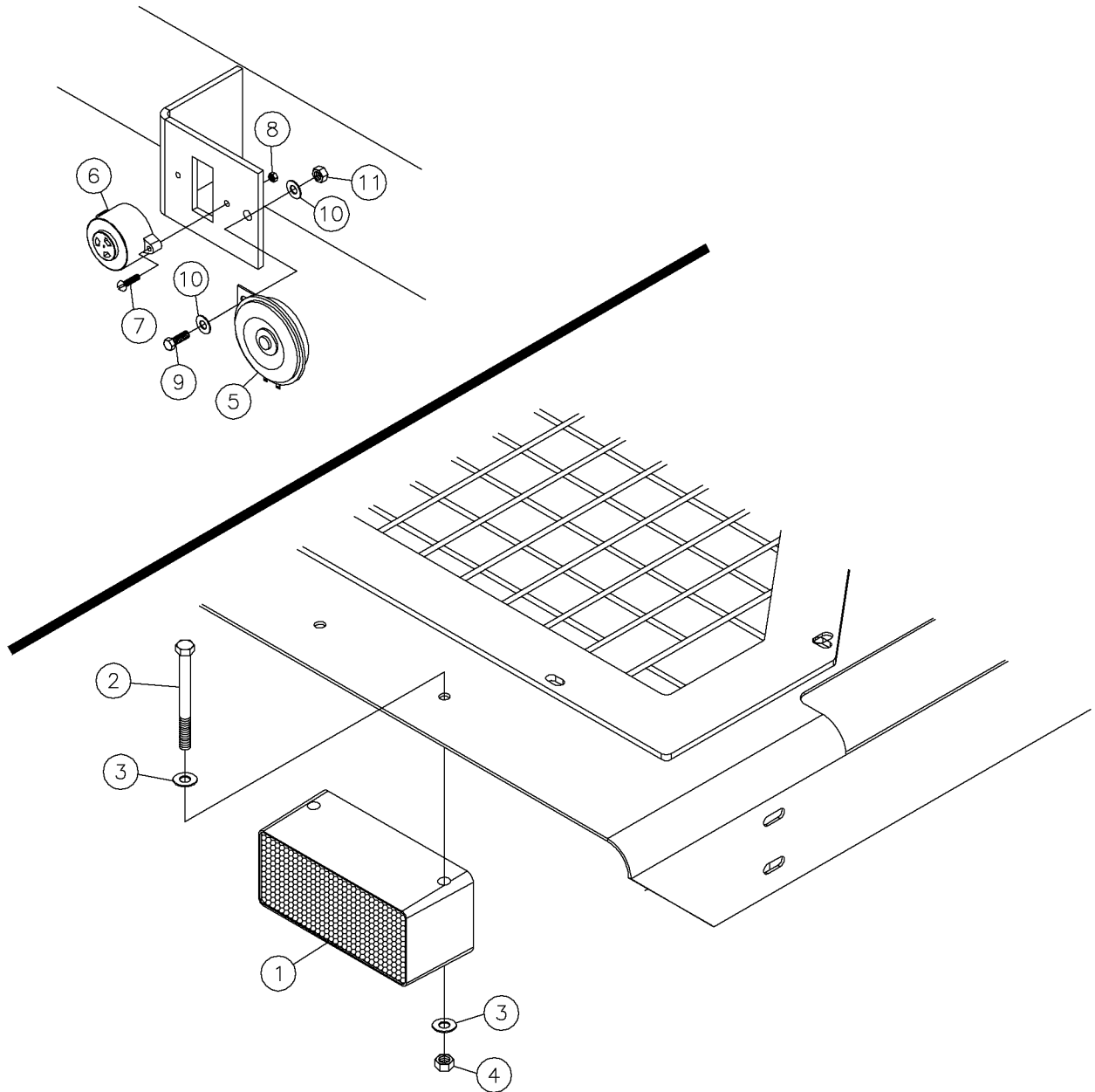

Control/Electrical-Back-Up/High Pitch/Zap Alert Horn Assy Fig 7-9

REF. NO.	*	PART NO.	DESCRIPTION	QTY.	REMARKS
1		614929001	ALARM - BACKUP	1	
2		238246001	BOLT 3/8"-16 X 4 1/2" GR8 HEX	2	
3		235713001	WASHER-3/8 SAE HARD ZINC PLTD	2	
4		235725001	NUT-3/8-16 GR8 ZINC PLTD	2	
5		283063001	HORN-MACHINE	1	
6		285617001	HORN - ZAP ALERT 2 PIN DEUTCSH	1	
7		1802010	BOLT - 3/16" X 1" NC STOVE	2	
8		400001	NUT-3/16 NC HEX	2	
9		235742001	BOLT-5/16-18X3/4 GR8 ZINC PLTD	1	
10		235714001	WASHER-5/16 SAE HARD ZINC PLTD	2	
11		235741001	NUT-5/16-18 GR8 ZINC PLTD	1	

Control/Electrical-DT Series Connectors Fig 7-10

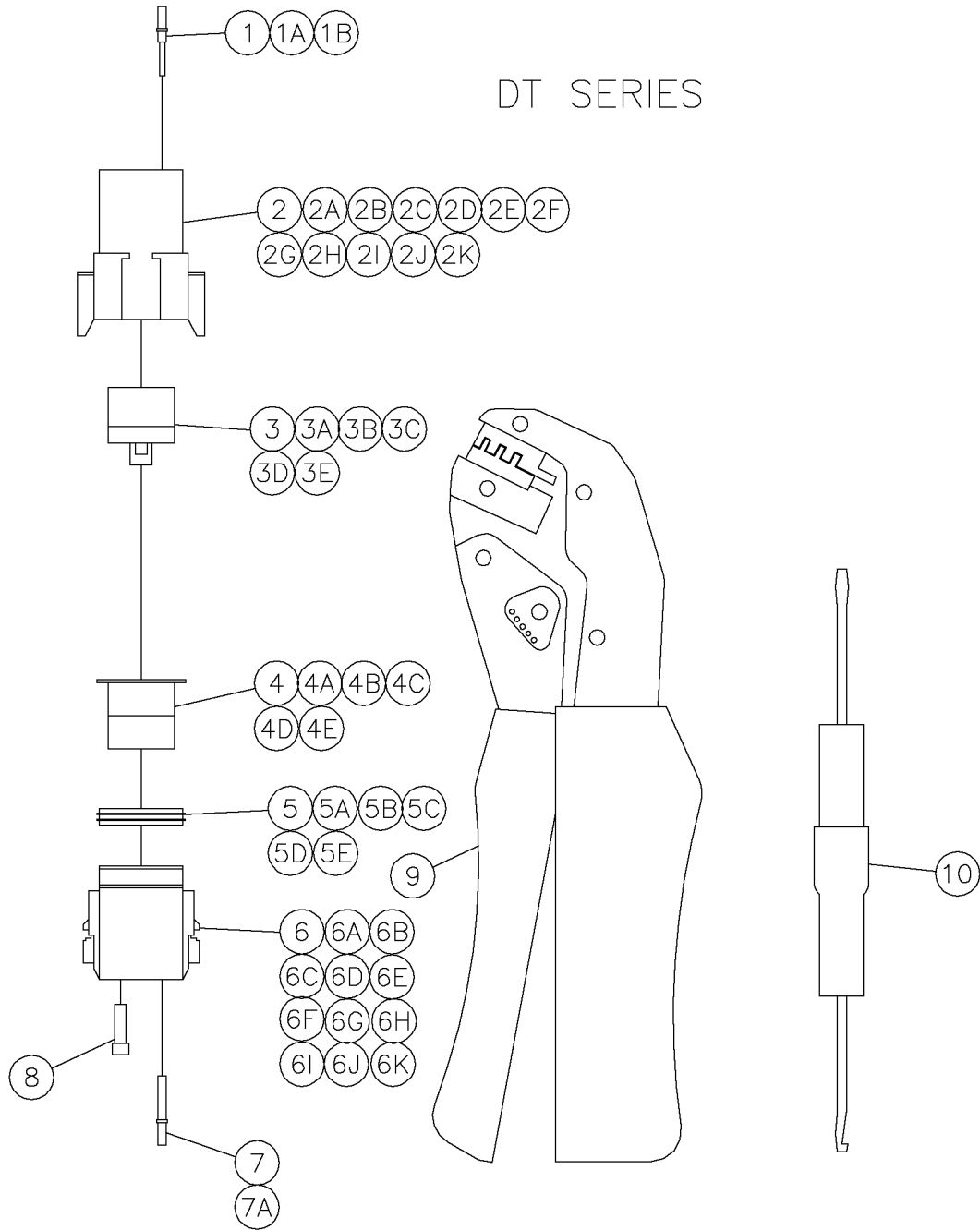

Control/Electrical-DT Series Connectors Fig 7-10

REF. NO.	*	PART NO.	DESCRIPTION	QTY.	REMARKS
1		276866001	PIN - 14/16 GA.		
1A		87696001	PIN-16/18 GA.		
1B		276951001	PIN - (20 GA.)		
2		276867001	RECEPTACLE - 2 PIN		
2A		276868001	RECEPTACLE - 3 PIN		
2B		276869001	RECEPTACLE - 4 PIN		
2C		276890001	RECEPTACLE - 6 PIN		
2D		276943001	RECEPTACLE - 8 PIN (A)		
2E		276944001	RECEPTACLE - 8 PIN (B)		
3		276870001	WEDGE - 2 PIN RECEPTACLE		
3A		276871001	WEDGE - 3 PIN RECEPTACLE		
3B		276872001	WEDGE - 4 PIN RECEPTACLE		
3C		276873001	WEDGE - 6 PIN RECEPTACLE		
3D		94200001	WEDGE - 8 PIN RECEPTACLE		
3E		103213001	WEDGE - 12 PIN RECEPTACLE		
4		276874001	WEDGE - 2 PIN PLUG		
4A		276875001	WEDGE - 3 PIN PLUG		
4B		276876001	WEDGE - 4 PIN PLUG		
4C		276877001	WEDGE - 6 PIN PLUG		
4D		98106001	WEDGE - 8 PIN PLUG		
4E		103214001	WEDGE - 12 PIN PLUG		
5		276878001	GASKET - INTERFACE 2 PIN		
5A		276879001	GASKET - INTERFACE 3 PIN		
5B		276880001	GASKET - INTERFACE 4 PIN		
5C		276881001	GASKET - INTERFACE 6 PIN		
5D		276882001	GASKET - INTERFACE 8 PIN		
5E		276883001	GASKET - INTERFACE 12 PIN		
6		276884001	PLUG - 2 PIN		
6A		276885001	PLUG - 3 PIN		
6B		276886001	PLUG - 4 PIN		
6C		276887001	PLUG - 6 PIN		
6D		98107001	PLUG - 8 PIN (A)		
6E		276985001	PLUG - 8 PIN (B)		
7		91354001	SOCKET - 16/18 GA.		
7A		276916001	SOCKET - 20 GA.		
8		94201001	PLUG - SEALING (12-16)		
9		286553001	TOOL - DEUTSCH CRIMPING (FIELD)		
10		286553003	TOOL - DEUTSCH (FIELD)		
2F		276945001	RECEPTACLE - 8 PIN (C)		
2G		276946001	RECEPTACLE - 8 PIN (D)		
2H		276947001	RECEPTACLE - 12 PIN (A)		
2I		276948001	RECEPTACLE - 12 PIN (B)		
2J		276949001	RECEPTACLE - 12 PIN (C)		
2K		276950001	RECEPTACLE - 12 PIN (D)		
6F		276986001	PLUG - 8 PIN (C)		
6G		276987001	PLUG - 8 PIN (D)		
6H		103211001	PLUG - 12 PIN (A)		
6I		276988001	PLUG - 12 PIN (B)		
6J		276989001	PLUG - 12 PIN (C)		
6K		276990001	PLUG - 12 PIN (D)		

Control/Electrical-DRC Series Fig 7-11

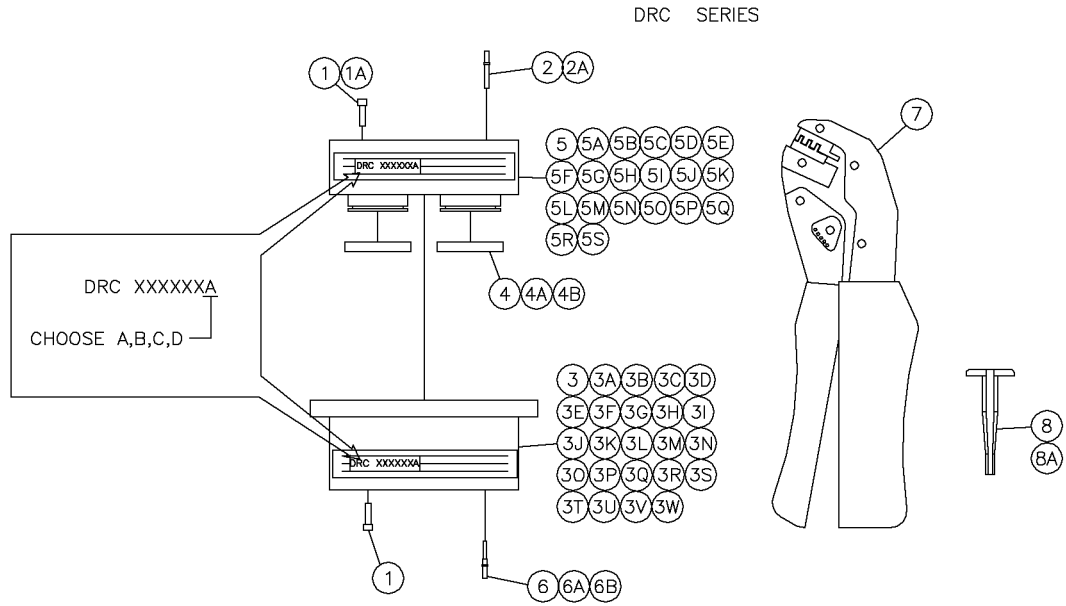

Control/Electrical-DRC Series Fig 7-11

REF. NO.	*	PART NO.	DESCRIPTION	QTY.	REMARKS
1		276906001	PLUG - SEALING (20)		
1A		94201001	PLUG - SEALING (12-16)		
2		91354001	SOCKET - 16/18 GA.		
2A		276916001	SOCKET - 20 GA.		
3		276894001	RECEPTACLE - 24 PIN INLINE (A)		
3A		276907001	RECEPTACLE - 24 PIN INLINE (B)		
3B		276917001	RECEPTACLE - 24 PIN INLINE (C)		
3C		276918001	RECEPTACLE - 24 PIN INLINE (D)		
3D		276895001	RECEPTACLE - 24 IN FLNG MNT (A)		
3E		276908001	RECEPTACLE - 24 PIN FLNG MNT (B)		
3F		276919001	RECEPTACLE - 24 PIN FLNG MNT (C)		
3G		276920001	RECEPTACLE - 24 PIN FLNG MNT (D)		
3H		276896001	RECEPTACLE - 40 PIN INLINE (A)		
3I		276909001	RECEPTACLE - 40 PIN INLINE (B)		
3J		276921001	RECEPTACLE - 40 PIN INLINE (C)		
3K		276922001	RECEPTACLE - 40 PIN INLINE (D)		
3L		276897001	RECEPTACLE - 40 PIN FLNG MNT (A)		
3M		276910001	RECEPTACLE - 40 PIN FLNG MNT (B)		
3N		276923001	RECEPTACLE - 40 PIN FLNG MNT (C)		
3O		276924001	RECEPTACLE - 40 PIN FLNG MNT (D)		
3P		276898001	RECEPTACLE - 70 PIN INLINE (A)		
3Q		276911001	RECEPTACLE - 70 PIN INLINE (B)		
3R		276925001	RECEPTACLE - 70 PIN INLINE (C)		
3S		276926001	RECEPTACLE - 70 PIN INLINE (D)		
3T		276899001	RECEPTACLE - 70 PIN FLNG MNT (A)		
3U		276912001	RECEPTACLE - 70 PIN FLNG MNT (B)		
3V		276927001	RECEPTACLE - 70 PIN FLNG MNT (C)		
3W		276928001	RECEPTACLE - 70 PIN FLNG MNT (D)		
4		276900001	GASKET - 24 PIN INTERFACE		
4A		276901001	GASKET - 40 PIN INTERFACE		
4B		276902001	GASKET - 70 PIN INTERFACE		

Control/Electrical-DRC Series (Continued) Fig 7-11

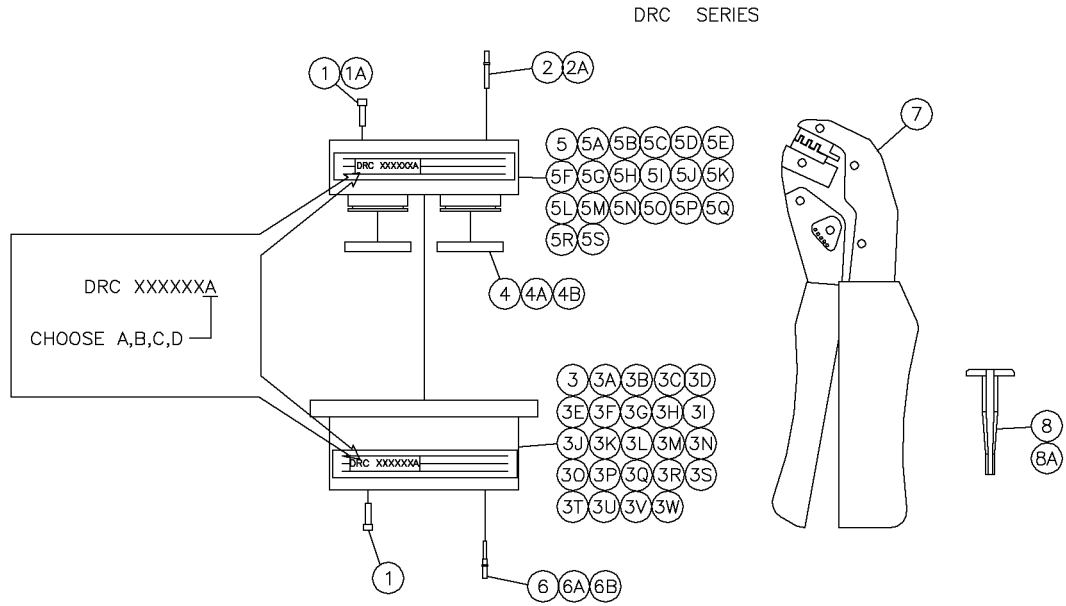

Control/Electrical-DRC Series (Continued) Fig 7-11

REF. NO.	*	PART NO.	DESCRIPTION	QTY.	REMARKS
5		276931001	PLUG - 24 PIN (SIZE 20 CONTACTS) (A)		
5A		276932001	PLUG - 24 PIN (SIZE 20 CONTACTS)		
5B		276933001	PLUG - 24 PIN (SIZE 20 CONTACTS) (C)		
5C		276934001	PLUG - 24 PIN (SIZE 20 CONTACTS) (D)		
5D		276939001	PLUG - 40 PIN (SIZE 20 CONTACTS) (A)		
5E		276940001	PLUG - 40 PIN (SIZE 20 CONTACTS) (B)		
5F		276941001	PLUG - 40 PIN (SIZE 20 CONTACTS) (C)		
5G		276942001	PLUG - 40 PIN (SIZE 20 CONTACTS) (D)		
5H		276903001	PLUG - 24 PIN (A)		
5I		276913001	PLUG - 24 PIN (B)		
5J		276929001	PLUG - 24 PIN (C)		
5K		276930001	PLUG - 24 PIN (D)		
5L		276904001	PLUG - 40 PIN (A)		
5M		276914001	PLUG - 40 PIN (B)		
5N		276935001	PLUG - 40 PIN (C)		
5O		276936001	PLUG - 40 PIN (D)		
5P		276905001	PLUG - 70 PIN (A)		
5Q		276915001	PLUG - 70 PIN (B)		
5R		276937001	PLUG - 70 PIN (C)		
5S		276938001	PLUG - 70 PIN (D)		
6		276866001	PIN - 14/16 GA.		
6A		87696001	PIN-16/18 GA.		
6B		276951001	PIN - (20 GA.)		
7		286553001	TOOL - DEUTSCH CRIMPING (FIELD)		
8		276892001	TOOL - 16/18 GA. EXTRACTOR (BLUE)		
8A		276893001	TOOL - 20/24 GA. EXTRACTOR (RED)		

Control/Electrical-Overhead Console Assy Fig 7-12r02

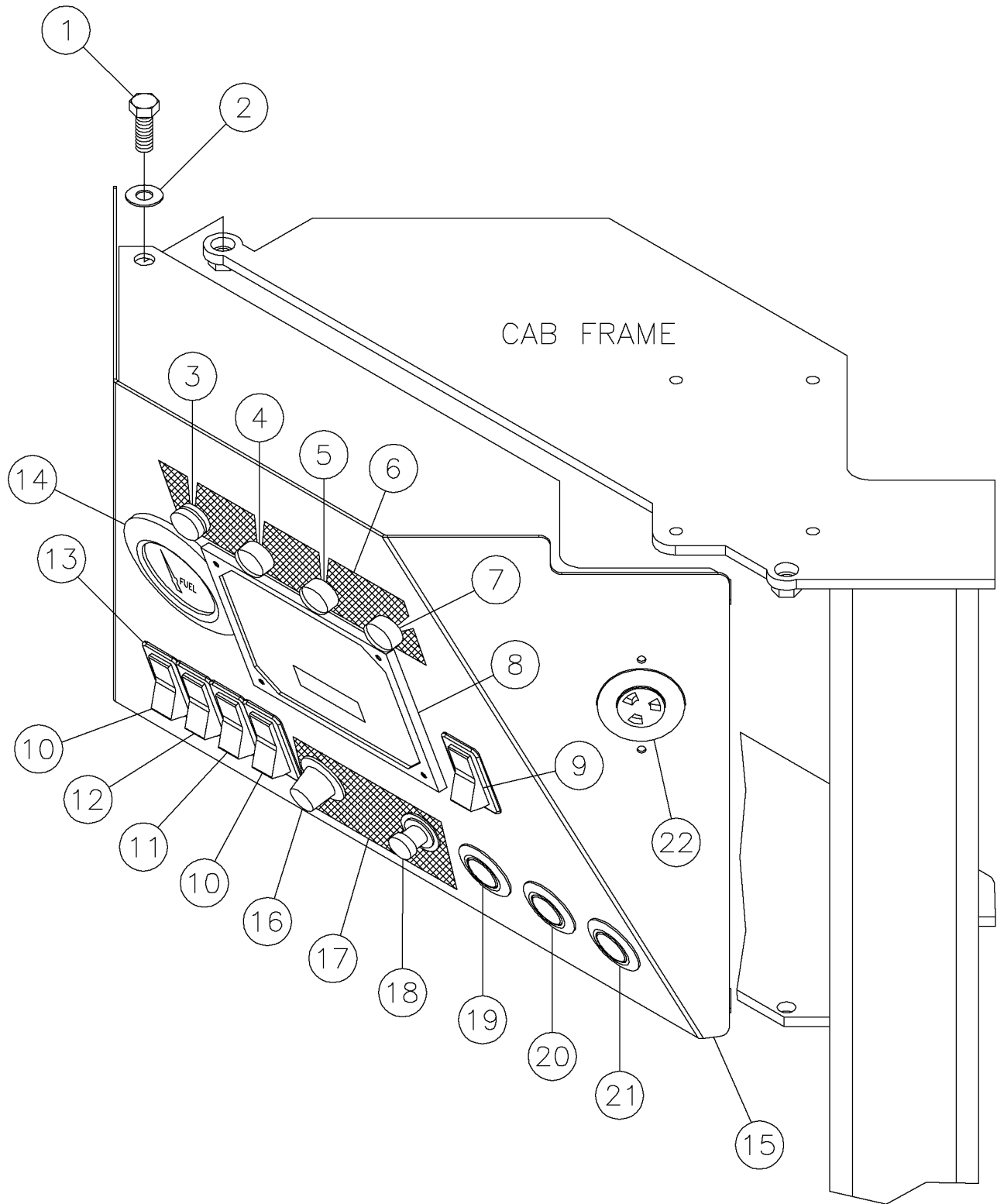

Control/Electrical-Overhead Console Assy Fig 7-12r02

REF. NO.	*	PART NO.	DESCRIPTION	QTY.	REMARKS
		Revision Date	October, 2004		Update In Illustration & Parts List.
1		235727001	BOLT-3/8-16X1 GR8 HEX ZINC PLT	4	
2		235713001	WASHER - FLATSTRL - .38 - .41 X .81 - .06-YA-A325	4	
3		260766001	SWITCH-MOM BUTTON NO	1	
4		27148001	LIGHT-RED WARNING	1	
5		86581001	LIGHT-WARNING (AMBER)	1	
6		700IC291	DECAL - REMOTE LOCKOUT	1	
7		81374001	LIGHT-GREEN WARNING #338-8049	1	
8		283155001	EMS MAIN DISPLAY - CAT ENGINE	1	
9		283069001	ROCKER SWITCH-SCROLL	1	
10		283087001	ROCKER SWITCH-WORK LIGHT	2	
11		283083001	ROCKER SWITCH-FRONT WASHER	1	
12		283084001	ROCKER SWITCH-FRONT WIPER	1	
13		614933001	GANG MOUNT - CENTER - EATON ROCKER SWITCH	4	(Included Ref. 9-12)
14		600095001	GAUGE-FUEL #107094	1	
15		296266998	DASH	1	
16		283007001	FAN SWITCH	1	
		78114001	CONTROL KNOB #409D2K1	1	
17		700IB614	DECAL - OVERHEAD CONTROLS	1	
18		283067001	CIGARETTE LIGHTER	1	
19		277695001	SWITCH - PUSH BUTTON ZAP ALERT RESET	1	
20		277696001	SWITCH - PUSH BUTTON ZAP ALERT VOLTAGE TEST	1	
21		277697001	SWITCH - PUSH BUTTON ZAP ALERT CURRENT TEST	1	
22		285617001	HORN - ZAP ALERT 2 PIN DEUTCSH	2	

Control/Electrical-Overhead Console Assy Fig 7-12r01

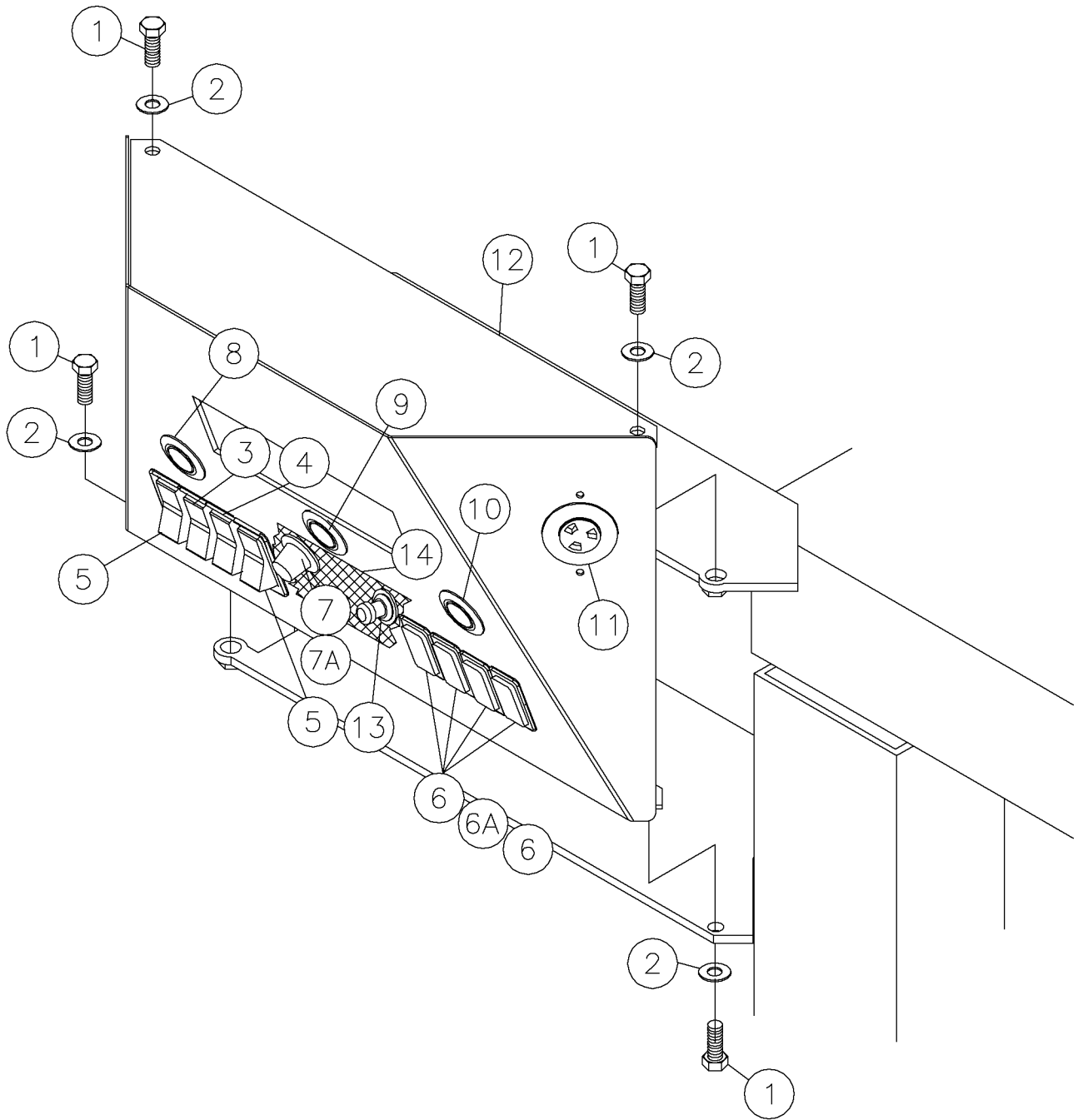

Control/Electrical-Overhead Console Assy Fig 7-12r01

REF. NO.	*	PART NO.	DESCRIPTION	QTY.	REMARKS
1		235727001	BOLT-3/8-16X1 GR8 HEX ZINC PLT	4	
2		235713001	WASHER-3/8 SAE HARD ZINC PLTD	4	
3		283084001	ROCKER SWITCH-FRONT WIPER	1	
4		283083001	ROCKER SWITCH-FRONT WASHER	1	
5		283087001	ROCKER SWITCH-WORK LIGHT	2	
6		609566001	PLUG - ROCKER SWITCH FILLER	4	
6A		614932001	END BEZEL-PANEL RACK	4	
6B		614933001	CENTER GANG RACK	4	
7		283007001	FAN SWITCH	1	
7A		78114001	CONTROL KNOB #409D2K1	1	
8		277695001	SWITCH - PUSH BUTTON ZAP ALERT RESET	1	
9		277696001	SWITCH - PUSH BUTTON ZAP ALERT VOLTAGE TEST	1	
10		277697001	SWITCH - PUSH BUTTON ZAP ALERT CURRENT TEST	1	
11		285617001	HORN - ZAP ALERT 2 PIN DEUTCSH	1	
12		296256404	PANEL - DASH	1	
13		283067001	CIGARETTE LIGHTER	1	
14		7001B614	DECAL - OVERHEAD CONTROLS	1	

Control/Electrical-Overhead Console Assy Fig 7-12

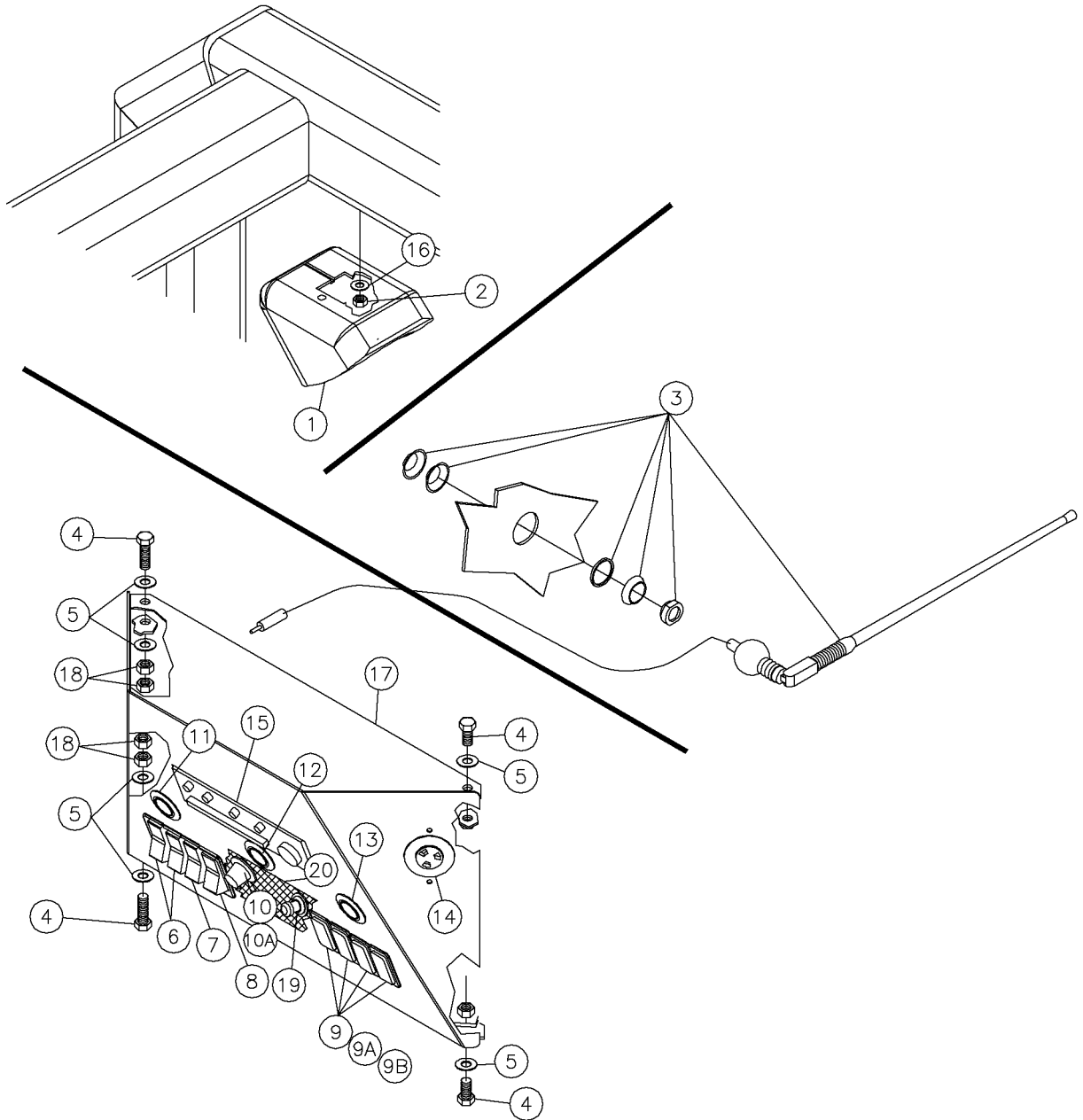

Control/Electrical-Overhead Console Assy Fig 7-12

REF. NO.	*	PART NO.	DESCRIPTION	QTY.	REMARKS
1		283055001	RADIO SPEAKER	2	
2		235741001	NUT-5/16-18 GR8 ZINC PLTD	2	
3		283056001	RADIO ANTENNA	1	
4		235727001	BOLT-3/8-16X1 GR8 HEX ZINC PLT	4	
5		235713001	WASHER-3/8 SAE HARD ZINC PLTD	6	
6		283087001	ROCKER SWITCH-WORK LIGHT	2	
7		283128001	ROCKER SWITCH-LEFT WIPER	1	
8		283129001	ROCKER SWITCH-LEFT WASHER	1	
9		609566001	PLUG - ROCKER SWITCH FILLER	4	
9A		614932001	END BEZEL-PANEL RACK	4	
9B		614933001	CENTER GANG RACK	4	
10		283007001	FAN SWITCH	1	
10A		78114001	CONTROL KNOB #409D2K1	1	
11		277695001	SWITCH - PUSH BUTTON ZAP ALERT RESET	1	
12		277696001	SWITCH - PUSH BUTTON ZAP ALERT VOLTAGE TEST	1	
13		277697001	SWITCH - PUSH BUTTON ZAP ALERT CURRENT TEST	1	
14		285617001	HORN - ZAP ALERT 2 PIN DEUTC SH	1	
15		283054001	RADIO - AM /FM MPX WITH CD PLAYER	1	
16		235714001	WASHER-5/16 SAE HARD ZINC PLTD	1	
17		296256404	PANEL - DASH	1	
18		235725001	NUT-3/8-16 GR8 ZINC PLTD	4	
19		283067001	CIGARETTE LIGHTER	1	
20		700IB614	DECAL - OVERHEAD CONTROLS	1	

Remote Lockout Assy Fig 7-13r01

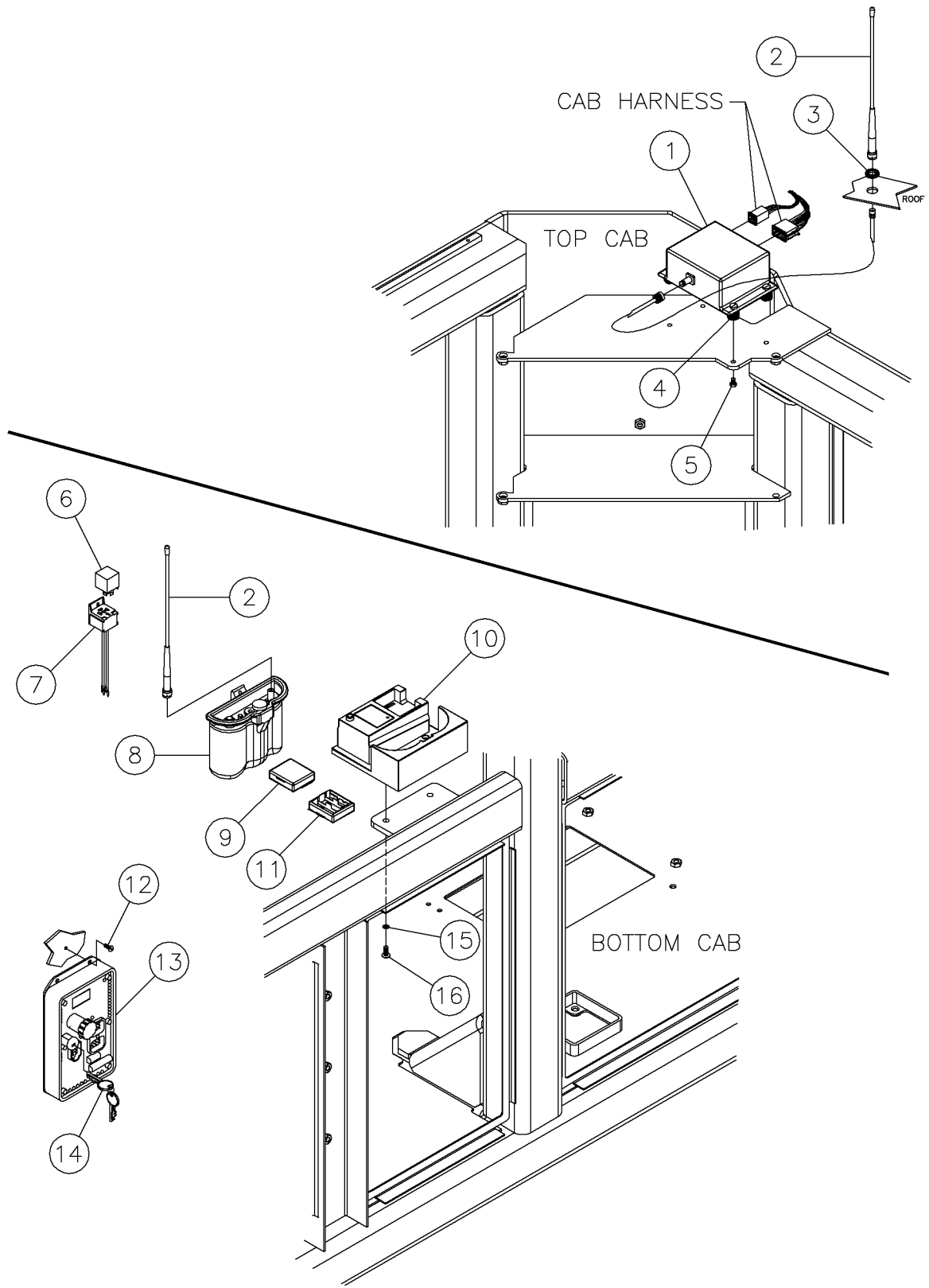

Rmote Lockout Assy Fig 7-13r01

REF. NO.	*	PART NO.	DESCRIPTION	QTY.	REMARKS
1		278530001	REMOTE LOCKOUT RADIO KIT (LOST RX 458)	1	
2		286918001	REMOTE LOCKOUT ANTENNA	2	
3		1865051	GROMMET-1/2IDX13/16ODX1/16 GR	1	
4		296252528	MOUNT, SHOCK RX M6X10	4	
5		507610010	SCREW-HFS,M6-1.00X10,10.9,YZ,D6921,FT	4	
6		283181001	RELAY-24V SPDT C-FORM W/RESISTOR	2	
7		283206001	CONTROL RELAY PIGTAIL - REMOTE LOCKOUT	2	
8		278560001	REMOTE LOCKOUT RADIO KIT (LOST TX 458)	1	
9		296250300	BATTERY - 3.5 VOLTS 1.2 AH	1	
10		286903001	REMOTE LOCKOUT DOCKING STATION	1	
11		296250302	BATTERY HOLDER 3-AA	1	
12		504543001	10-32X3/4 RH M/S ZP	4	
13		286905001	REMOTE LOCKOUT OVERRIDE	1	
14		296252962	KEY LOCK - RLE BOX	1	
15		485001	WASHER - FLATSTD - .19 - .22 X .56 - .05 - CZ	4	
16		533006	SCREW 10-24 X RD HD SLT " REPLACED BY "1802006"	4	

Remote Lockout Assy Fig 7-13

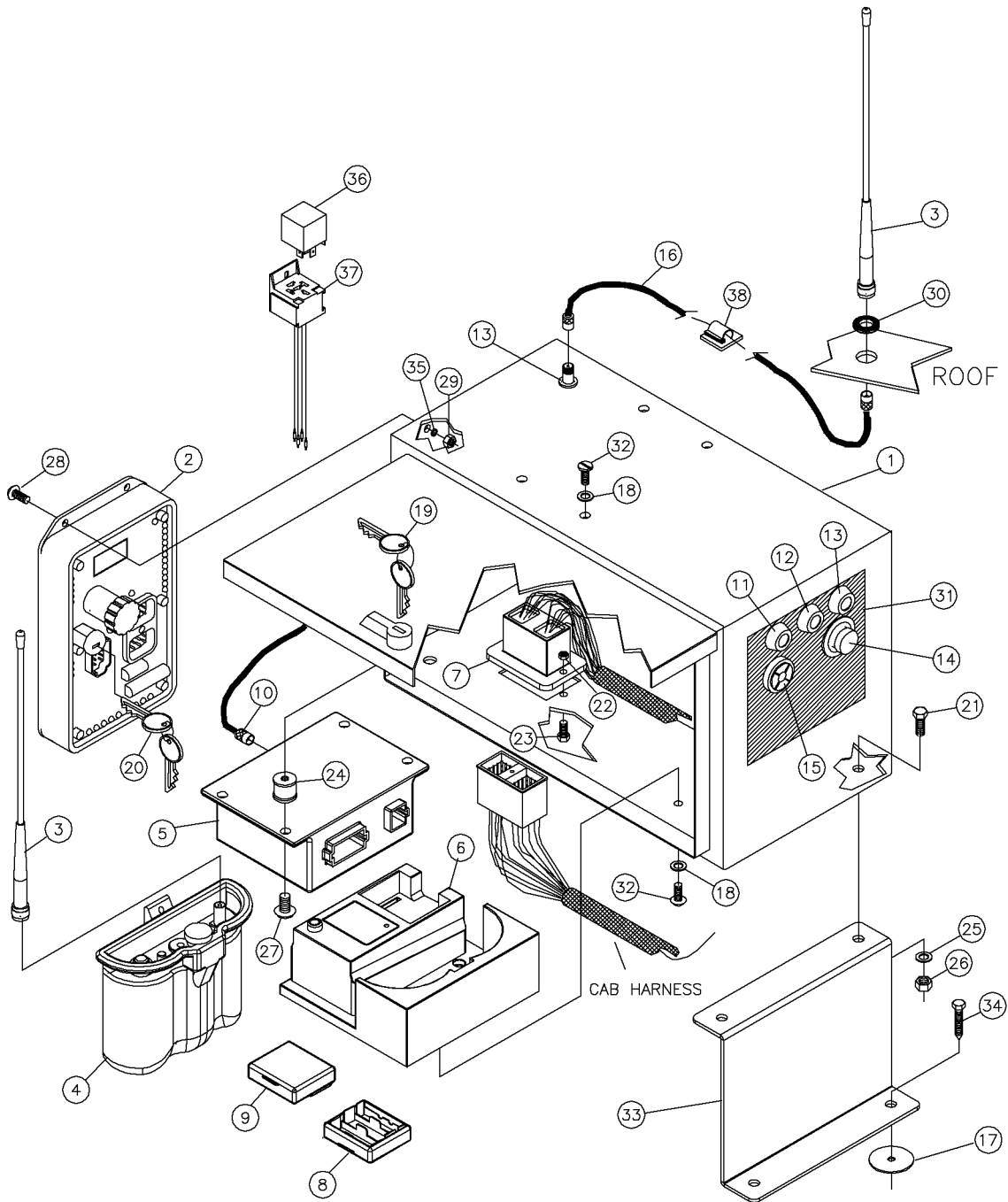

Rmote Lockout Assy Fig 7-13

REF. NO.	*	PART NO.	DESCRIPTION	QTY.	REMARKS
		Revision Date	June, 2002		Addition To Manual
1		287712001	BOX - REMOTE LOCKOUT	1	
2		286905001	REMOTE LOCKOUT OVERRIDE	1	
3		286918001	REMOTE LOCKOUT ANTENNA	2	
4		286917001	REMOTE LOCKOUT RADIO KIT (LOST TX 434)	1	
5		286904001	REMOTE LOCKOUT RADIO KIT (LOST RX 434)	1	
6		286903001	REMOTE LOCKOUT DOCKING STATION	1	
7		287711001	HARNES - LOCKOUT BOX	1	
8		296250302	BATTERY PACK FOR AA BATTERIES	1	
9		296250300	BATTERY - 3.5 VOLTS 1.2 AH	1	
10		296252952	WIRE REMOTE LOCKOUT ANTENNA .5 METER	1	
11		296250334	LIGHT - PANNEL MOUNT GREEN LED W/ DEUTSCH	1	
11A		81374001	LIGHT-GREEN WARNING #338-8049	1	
12		296250333	LIGHT - PANNEL MOUNT RED LIGHT W/ DEUTSCH	2	
12A		70889001	BULB. #112-1418	2	
13		296250301	CONNECTOR BULK HEAD	1	
14		260766001	SWITCH-MOM BUTTON NO	1	
15		286920001	REMOTE LOCKOUT BUZZER	1	
16		286919001	REMOTE LOCKOUT CABELING FOR ANTENNA	1	
17		296251377	WASHER	4	
18		485001	WASHER-3/16 FLAT	8	
19		296252962	KEYS	1	
20		296265539	KEYS-SET OF TWO	1	
21		235734001	BOLT-1/4-20X3/4 GR8 ZINC PLTD	4	
22		399001	NUT-8-32 HEX	2	
23		57200001	SCREW-#8-32X1/2 RND.HD.MACH.	2	
24		296252528	MOUNT, SHOCK RX M6X10	1	
25		235716001	WASHER-1/4 SAE HARD ZINC PLTD	4	
26		235732001	NUT-1/4-20 GR8 ZINC PLTD	4	
27		507610010	SCREW-HFS,M6-1.00X10,10.9,YZ,D6921,FT	8	
28		504543001	10-32X3/4 RH M/S ZP	4	
29		26692001	NUT-10-32 NF HEX	4	
30		1865051	GROMMET-1/2IDX13/16ODX1/16 GR	1	
31		700IB809	DECAL - REMOTE LOCKOUT	4	
32		533006	SCREW 10-24 X RD HD SLT	4	
33		283178001	MOUNT-REMOTE LOCKOUT	2	
34		296257376	SCREW-1/4 - 14 X 1 1/4 HWH DRILL SCREW	4	
35		480001	WASHER-3/16 S/T LOCK	4	
36		283181001	RELAY - VISE CONTROL	2	
37		283206001	CONTROL RELAY PIGTAIL - REMOTE LOCKOUT	2	
38		283207001	CLAMP - REMOTE LOCKOUT	6	

Vise Scissor Guard Assy S/N 111- Fig 8-1r03

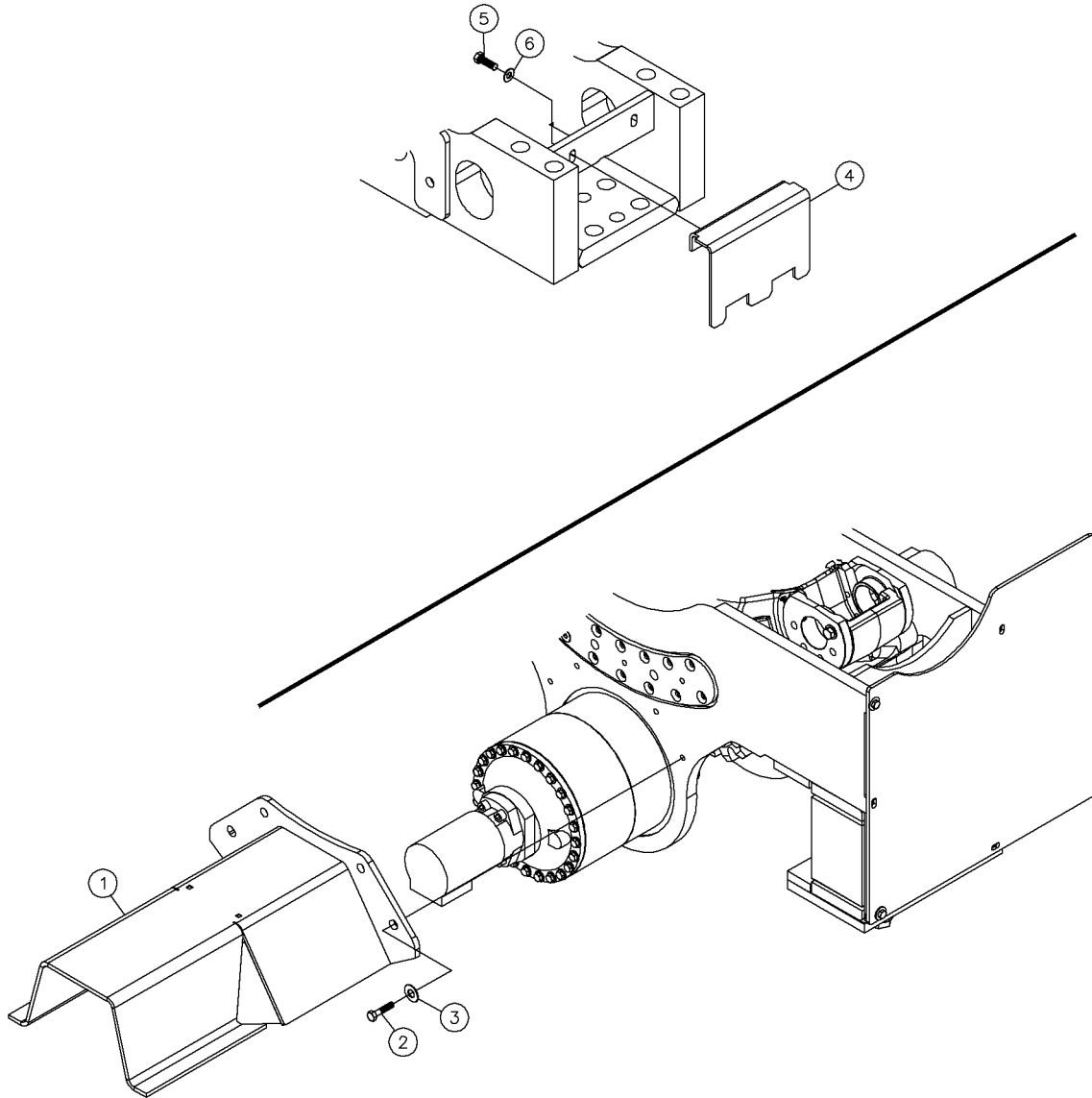

Vise Scissor Guard Assy S/N 111- Fig 8-1r03

REF. NO.	*	PART NO.	DESCRIPTION	QTY.	REMARKS
		Revision Date	October, 2004		Addition To Manual
1		296264188	WELDMENT - GUARD - HYD MTR	1	
2		235721001	BOLT-1/2-13X1 1/2 GR8 ZINC PLT	4	
3		485025	WASHER-1/2 FLAT-HARDENED-YZ	4	
4		296264175	WELDMENT - GUARD	2	
5		235736001	BOLT-3/8-16X1 1/4 ZINC PLTD	4	
6		510337607	WASHER-FLATSTD-.38-.44X1.00-.08-YZ	4	

Figure Deleted Fig 8-1r02

DELETED DUE TO UPDATE

Figure Deleted Fig 8-1r02

REF. NO.	*	PART NO.	DESCRIPTION	QTY.	REMARKS
		Revision Date	June. 2002		Vise Replaced by Scissors Vise - Information Located Fig 8-2 -

Vise Box - Assy S/N 97-104 & 106 Fig 8-1r01

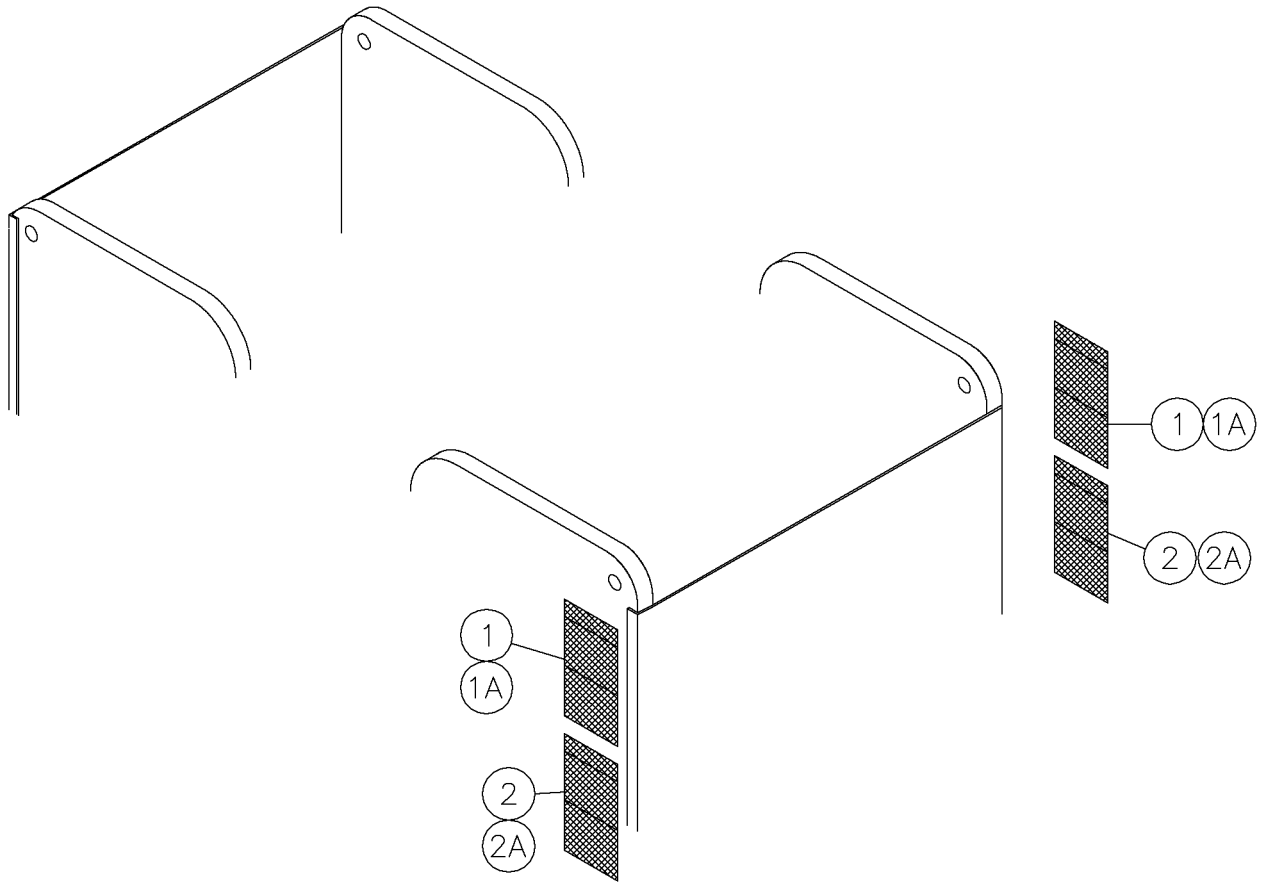

Vise Box - Assy S/N 97-104 & 106 Fig 8-1r01

REF. NO.	*	PART NO.	DESCRIPTION	QTY.	REMARKS
		Revision Date	June, 2002		Update Illustration
1		7000A393	DECAL - DANGER	2	
1A		700IA393	DECAL - DANGER	2	International
2		7000A394	DECAL - WARNING	2	
2A		700IA394	DECAL - WARNING	2	International

Vise Box - Assy Fig 8-1

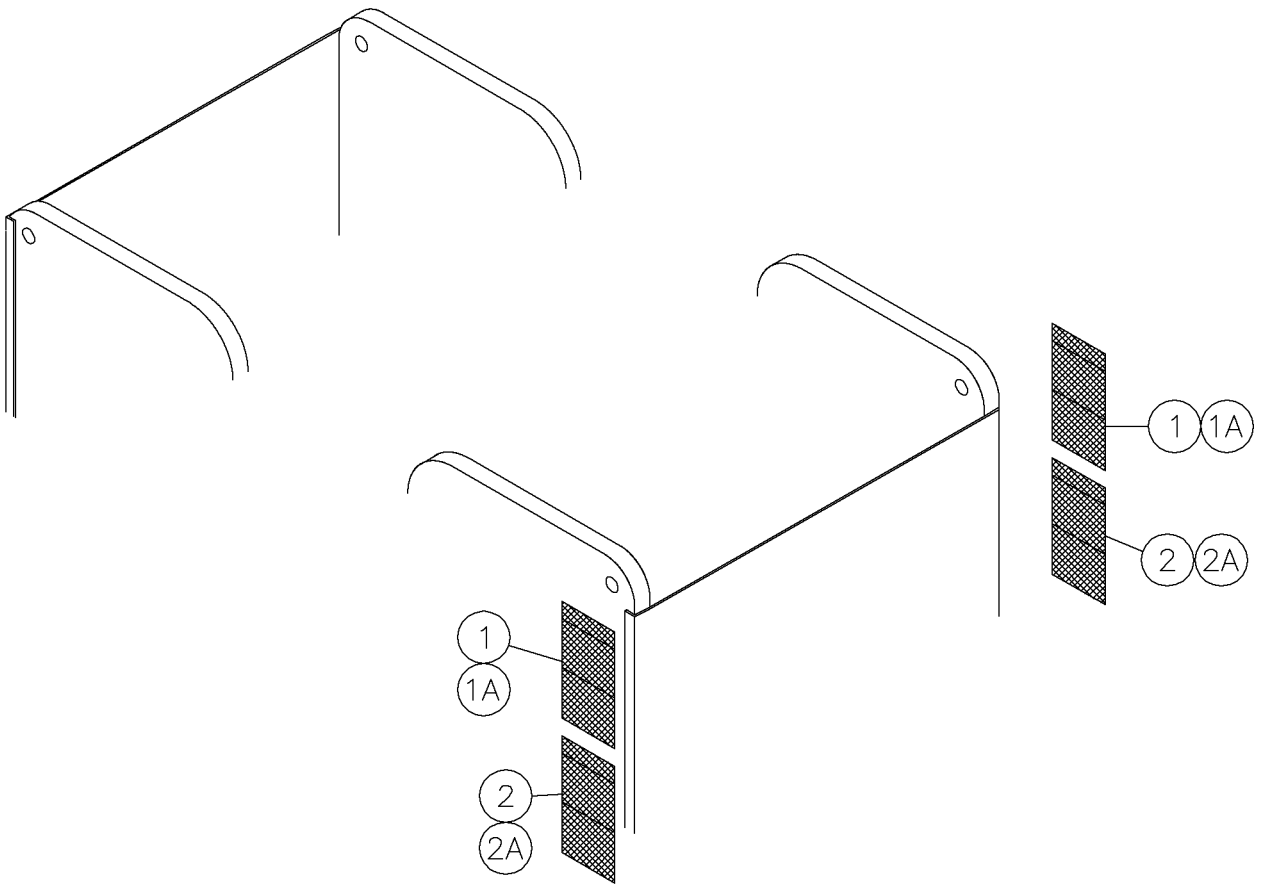

Vise Box - Assy Fig 8-1

REF. NO.	*	PART NO.	DESCRIPTION	QTY.	REMARKS
1		7000A393	DECAL - DANGER	2	
1A		700IA393	DECAL - DANGER	2	International
2		7000A394	DECAL - WARNING	2	
2A		700IA394	DECAL - WARNING	2	International

Vise Box-Bridge Assy S/N 111- Fig 8-2r01

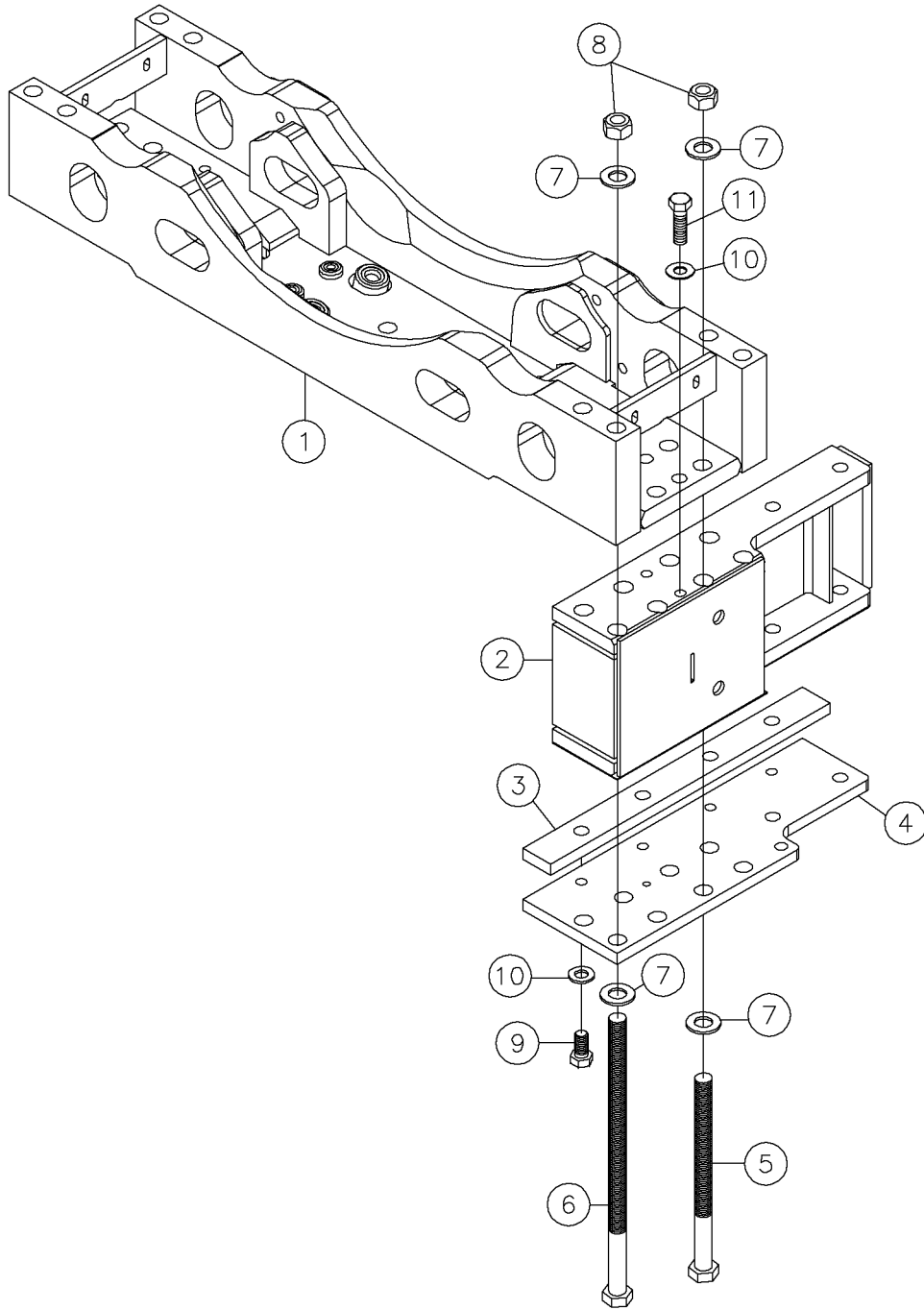

Vise Box-Bridge Assy S/N 111- Fig 8-2r01

REF. NO.	*	PART NO.	DESCRIPTION	QTY.	REMARKS
		Revision Date	October, 2004		Update In Illustration & Parts List.
1		296264131	MACHINE - FIXED VISE FRAME D300	1	
2		296264158	MACHINE-FRONT BRIDGE -RHS	2	
3		296264138	WEAR PAD - NYLATRON -.75 X 2.25 X 22.75	2	
4		296264137	RETAINER PLATE - LWR VISE	2	
5		296264183	SCREW-HCS-1.00-14-UNSX13.25-GR8-YZ-RLD	8	
6		296264184	SCREW-HCS-1.00-14-UNSX19.25-GR8-YZ-RLD	4	
7		238892001	WASHER-1" HARDENED FLAT ZY	24	
8		296264185	NUT - HEX - 1.00-14-GR8-YZ	12	
9		238217001	BOLT-3/4-10X1 1/2 GR8 HEX ZYC	8	
10		295016001	WASHER, USF CUT IRON	12	
11		238880001	BOLT-3/4-10X2 1/2 HHCS GR8 ZY	4	

Vise Box-Bridge Assy S/N 105 & 107-110 Fig 8-2

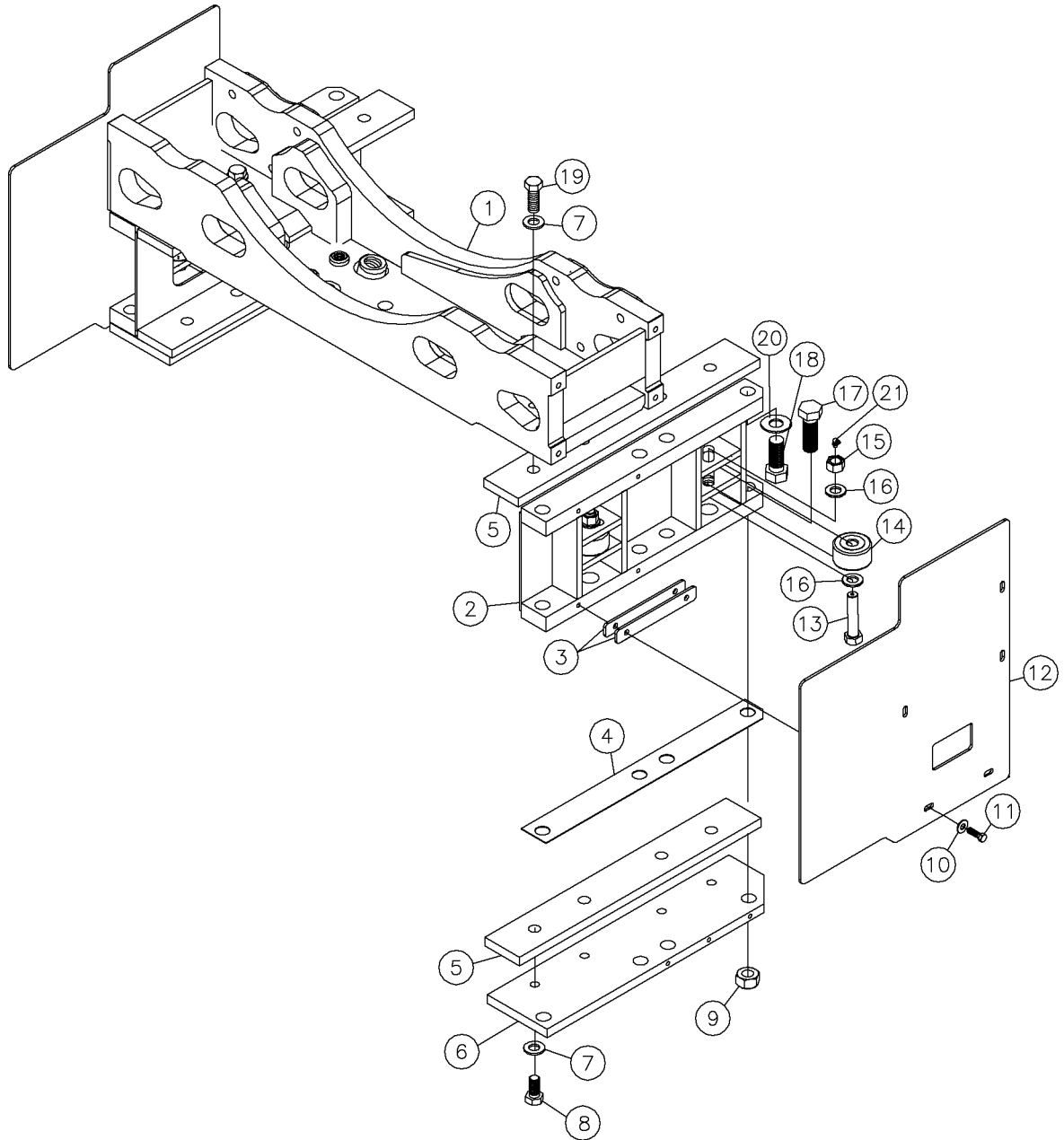

Vise Box-Bridge Assy S/N 105 & 107-110 Fig 8-2

REF. NO.	*	PART NO.	DESCRIPTION	QTY.	REMARKS
		Revision Date	June, 2002		Addition To Manual
1		296261603	BOX-FIXED VISE MACHINE	1	
2		296261638	MACHINE-VISE BRIDGE	2	
3		296265339	SHIM-GUARD-FIXED	4	
4		296265310	SHIM-VISE BRIDGE	2	
5		296261601	WEAR PAD - NYLON - 24.25"	4	
6		296265290	PLATE- BRIDGE	2	
7		295016001	WASHER, SAE FLAT 3/4	12	
8		238217001	BOLT-3/4-10X1 1/2 GR8 HEX ZYC	8	
9		75390001	NUT-1-UNC GR.8 TOP LOCK HEX	8	
10		510337607	WASHER-FLATSTD-.38-.44X1.00-.08-YZ	10	
11		235736001	BOLT-3/8-16X1 1/4 ZINC PLTD	10	
12		296265312	VISE-GUARD FRONT	2	
13		296265371	BOLT - GREASE .75-10 X 3.50)	4	
14		288482001	ROLLER - 2 3/4 CAM	4	
15		235739001	NUT-3/4-10 GR8 ZINC PLTD	4	
16		235717001	WASHER-3/4 FLAT HARDENED YELLOW ZINC	8	
17		238887001	BOLT-1-8 X 3 HHCS GR8 ZY	8	
18		388024	BOLT-1-UNCX2 1/2 GR.8 HEX	8	
19		235746001	BOLT-3/4-10X2 GR8 HEX ZNC PLTD	4	
20		238892001	WASHER-1" HARDENED FLAT ZY	8	
21		597001	ZERK-1/4" NF 90 DEG GREASE REF T03633	4	

Vise Box Plumbing Assy S/N 111- Fig 8-3r01

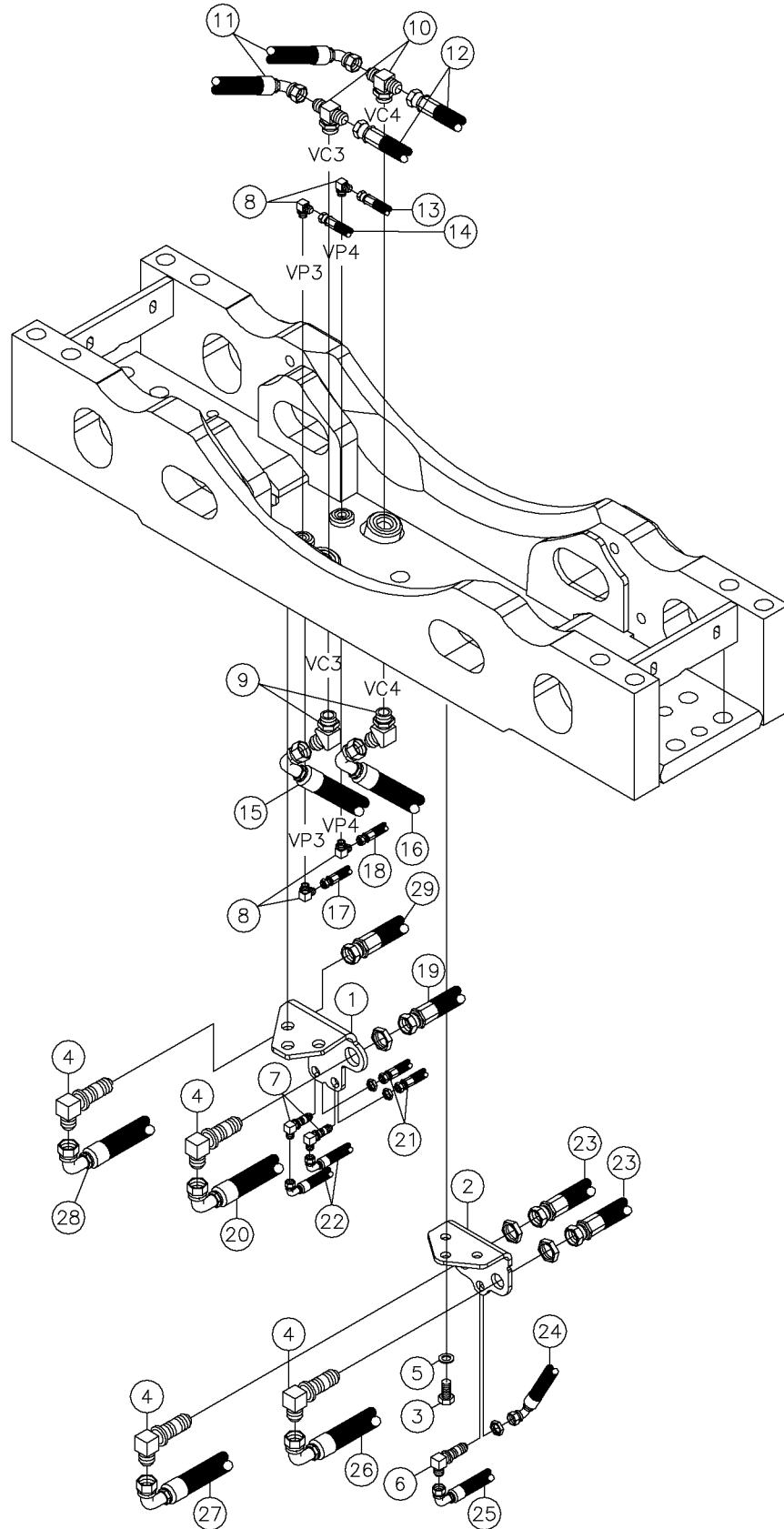

Vise Box Plumbing Assy S/N 111- Fig 8-3r01

REF. NO.	*	PART NO.	DESCRIPTION	QTY.	REMARKS
		Revision Date	October, 2004		Update In Illustration & Parts List.
1		296264186	BRACKET - BULKHEAD - D300 VISE	1	
2		296264187	BRACKET - BULKHEAD - ROT. MTR.	1	
3		235729001	SCREW-HCS-.50-13X1.00-GR8-YZ	6	
4		77735001	FITTING - BH90 - 10MJ - 10MJ - LN	3	
5		485025	WASHER-1/2 FLAT-HARDENED-YZ	6	
6		60727001	FITTING-6MJICX90BULKHEAD ELBOW	2	
7		61497001	FITTING-4M JIC BULKHEAD 90DEG.	2	
8		59423001	FIT-4M JICX4M ADJ.90 DEG.ELBOW	4	
9		296265422	FITTING-45-10MJ-10MORBA-FRG	2	
10		615104001	FITTING - BTEE-8MJ-8MJ-10MORB	2	
11		296061001	HOSE-HYD-.50 X 15.5 8FSJST45-3000PSIBNS	2	
12		296062001	HOSE-HYD.50X25-8FSJST/45-3000PSI BNS	2	
13		296077001	HOSE-HYD-.25 X 22 3FSJ ST/ST 3000PSI	1	
14		53843183	HOSE-1/4X18 4FS JIC 3000 PSI	1	
15		296060001	HOSE-HYD-.63 X 30.5 10FSJ ST/90 3000PSI	1	
16		296259057	HOSE-HYD-.63 X 26.5 10FSJ ST/90 3000PSI	1	
17		296078001	HOSE-HYD-.25 X18.5 4FSJ ST/45 3000PSI	1	
18		296079001	HOSE-HYD-.25 X 14.5 4FSJ ST/45 3000 PSI	1	
19		53842489	HOSE 5/8X27 10FSJICST 3000PSI	1	
20		296058001	HOSE-HYD -.63 X 43 10FSJ ST/90 3000PSI	1	
21		296073001	HOSE-HYD-.25 X 17.5 4FSJ ST/90 3000PSI	2	
22		296075001	HOSE-HYD-.25 X 42 4FSJ ST/90 3000PSI	2	
23		275125001	HOSE-5/8X23 10FSJIC ST/45 M3K	2	
24		296055001	HOSE-HYD-.38 X 28 6FSJ ST/45 3000PSI	1	
25		296054001	HOSE-HYD-.38 X 36 6FSJ 90/90 270 ORIENT	1	
26		257511001	HOSE-HYD-.63X37-10FSJ-ST/90-M3KMTF	1	
27		296053001	HOSE-HYD-.63 X 36 10FSJ 90/90-90 ORIENT	1	
28		296057001	HOSE-HYD-.63 X 45.5 10FSJ90/90-310ORIENT	1	
29		53842489	HOSE 5/8X27 10FSJICST 3000PSI	1	

Vise Box Plumbing Assy S/N 105 & 107-110 Fig 8-3

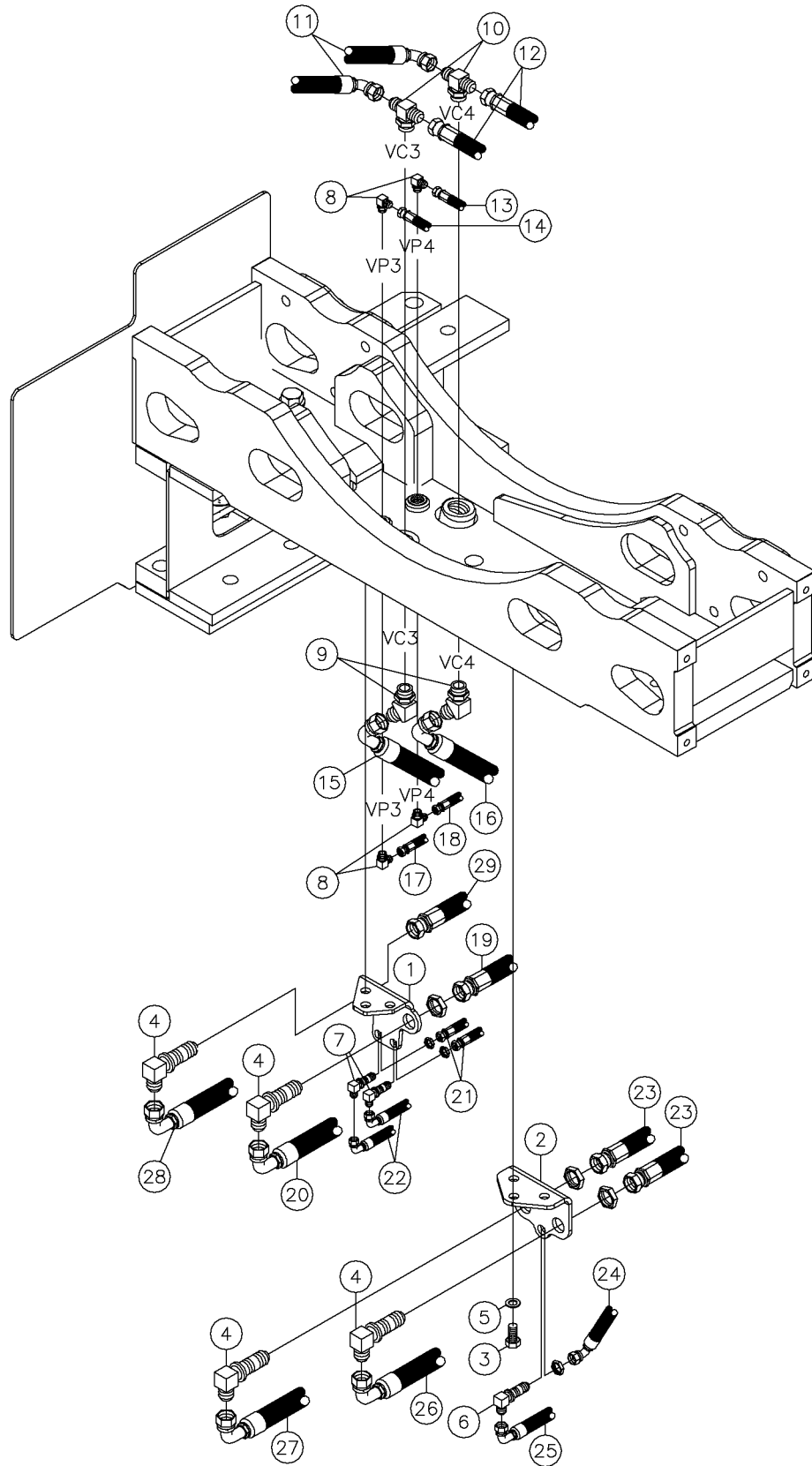

Vise Box Plumbing Assy S/N 105 & 107-110 Fig 8-3

REF. NO.	*	PART NO.	DESCRIPTION	QTY.	REMARKS
		Revision Date	June, 2002		Addition To Manual
1		296265344	BRACKET-BULKHEAD-VISE	1	
2		296265345	BRACKET-BULKHEAD-ROT.MTR.	1	
3		235729001	SCREW-HCS-.50-13X1.00-GR8-YZ	6	
4		77735001	FITTING-10M JIC BULKHEAD 90DEG	3	
5		485025	WASHER-1/2 FLAT-HARDENED-ZINC	6	
6		60727001	FITTING-6MJICX90BULKHEAD ELBOW	1	
7		61497001	FITTING-4M JIC BULKHEAD 90DEG.	2	
8		59423001	FIT-4M JICX4M ADJ.90 DEG.ELBOW	4	
9		296265422	FITTING-45-10MJ-10MORB-FRG	2	
10		615104001	FITTING - BTEE-8MJ-8MJ-10MORB	2	
11		296061001	HOSE-HYD-.50 X 15.5 8FSJ ST/45 3000PSI	2	
12		296062001	HOSE-HYD-.50 X 25 8FSJ ST/45 3000PSI	2	
13		296077001	HOSE-HYD-.25 X 22 3FSJ ST/ST 3000PSI	1	
14		53843183	HOSE-1/4X18 4FS JIC 3000 PSI	1	
15		296060001	HOSE-HYD-.63 X 30.5 10FSJ ST/90 3000PSI	1	
16		296259057	HOSE-HYD-.63 X 26.5 10FSJ ST/90 3000PSI	1	
17		296078001	HOSE-HYD-.25 X18.5 4FSJ ST/45 3000PSI	1	
18		296079001	HOSE-HYD-.25 X 14.5 4FSJ ST/45 3000 PSI	1	
19		53842489	HOSE 5/8X27 10FSJICST 3000PSI	1	
20		296058001	HOSE-HYD -.63 X 43 10FSJ ST/90 3000PSI	1	
21		296073001	HOSE-HYD-.25 X 17.5 4FSJ ST/90 3000PSI	2	
22		296075001	HOSE-HYD-.25 X 42 4FSJ ST/90 3000PSI	2	
23		275125001	HOSE-5/8X23 10FSJIC ST/45 M3K	2	
24		296055001	HOSE-HYD-.38 X 28 6FSJ ST/45 3000PSI	1	
25		296054001	HOSE-HYD-.38 X 37 6FSJ 90/90 3000PSI	1	
26		257511001	HOSE-HYD-.63X37-10FSJ-ST/90-M3KMTF	1	
27		296053001	HOSE-HYD-.63 X 36 10FSJ 90/90 3000PSI	1	
28		296057001	HOSE-HYD-.63 X 45.5 10FSJ 90/90 3000PSI	1	
29		53842489	HOSE 5/8X27 10FSJICST 3000PSI	1	

Vise Scissor Assy S/N 111- Fig 8-4r01

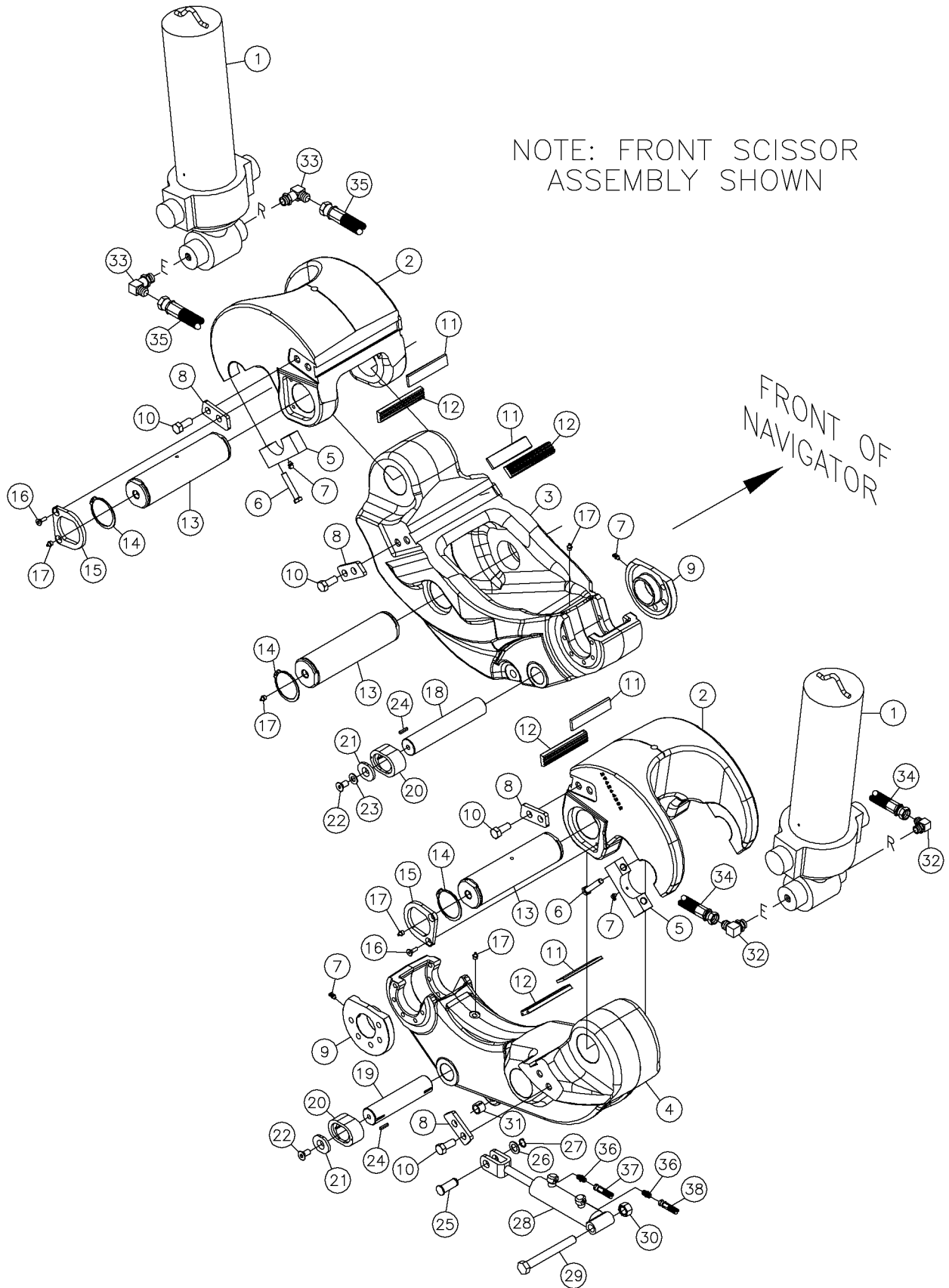

Vise Scissor Assy S/N 111- Fig 8-4r01

REF. NO.	*	PART NO.	DESCRIPTION	QTY.	REMARKS
		Revision Date	October, 2004		Update In Illustration & Parts List.
1		296267957	CYLINDER-5"X12.75"- 3.00"ROD(TRUNNION MNT	2	Breakdown Fig 12-46r01
2		296264201	MACHINING - TONG HEAD - 6.25 T.J.	2	
3		296264207	MACHINE - FEMALE LINK - D300	1	
4		296264209	MACHINE - MALE LINK -D300	1	
5		296265254	ENDCAP - TRUNION	4	
6		235744001	BOLT-1/2-13X2 3/4 GR8 ZNC PLTD	8	
7		597001	ZERK-1/4" NF 90 DEG GREASE	8	
8		296261598	STOP-TONG DIE	8	
9		296261599	RETAINER-TRUNION-RHS	4	
10		230727001	BOLT-5/8-11X1 1/2GR8 PLATED	16	
11		296264216	SPACER - TONG DIE - 5.18"	4	
12		296252194	TONG DIE 5.88	4	
13		296261644	PIN-SIZZOR VISE - 3.00	3	
14		600300	SNAP RING-#5100-300	6	
15		296264217	PIN LOCK	4	
16		95988010	CAPSCREW-3/8-16X1 FLTHD SOCKET	8	
17		586001	ZERK-1/8" ST NPT GREASE	5	
18		296261646	DRIVE-PIN-FEMALE	1	
19		296261650	DRIVE-PIN -MALE	1	
20		296264211	CAM - DRIVE PIN - 6.25 T.J.	4	
21		296261647	RETAINER-DRIVE PINE	2	
22		231974010	SCREW-1/2-13 X 1 FLT HD SOCKET	4	
23		485025	WASHER-1/2 FLAT-HARDENED-YZ	4	
24		577003	H KEYS 3/16 X 3/16 X 1	4	
25		296265304	PIN-LIFT CYLINDER	1	
26		483025	WASHER-1 1/4X3/4X14 GA M.B.	1	
27		600075	SNAP RING-#5100 EXT.3/4"	1	
28		296262569	HYD CYL - 1.75 X .75 X 4 STROKE	1	Breakdown Fig 12-42
29		385064	SCREW - HCS -3/4-10X6 1/2 GR 8 YZ	1	
30		235739001	NUT-3/4-10 GR8 ZINC PLTD	1	
31		296265305	BUSHING SPLIT .75ID X 1.00 OD X .75	1	
32		53837001	FITTING - 8M O-RING X 8M JIC 90 DEGREE	2	
33		278044001	FITTING -8MJ X 8MOR 90 - LONG	2	
34		296062001	HOSE-HYD.50X25-8FSJST/45-3000PSI BNS	2	
35		296061001	HOSE-HYD-.50 X 15.5 8FSJST45- 3000PSIBNS	2	
36		56648001	FITTING-4M JICX4M JIC STR.	2	
37		296077001	HOSE-HYD-.25 X 22 3FSJ ST/ST 3000PSI	1	
38		53843183	HOSE-1/4X18 4FS JIC 3000 PSI	1	
			Note: Qty's Listed Are For Only One Scissor Assy		

Vise Scissor Assy S/N 105 & 107-110 Fig 8-4

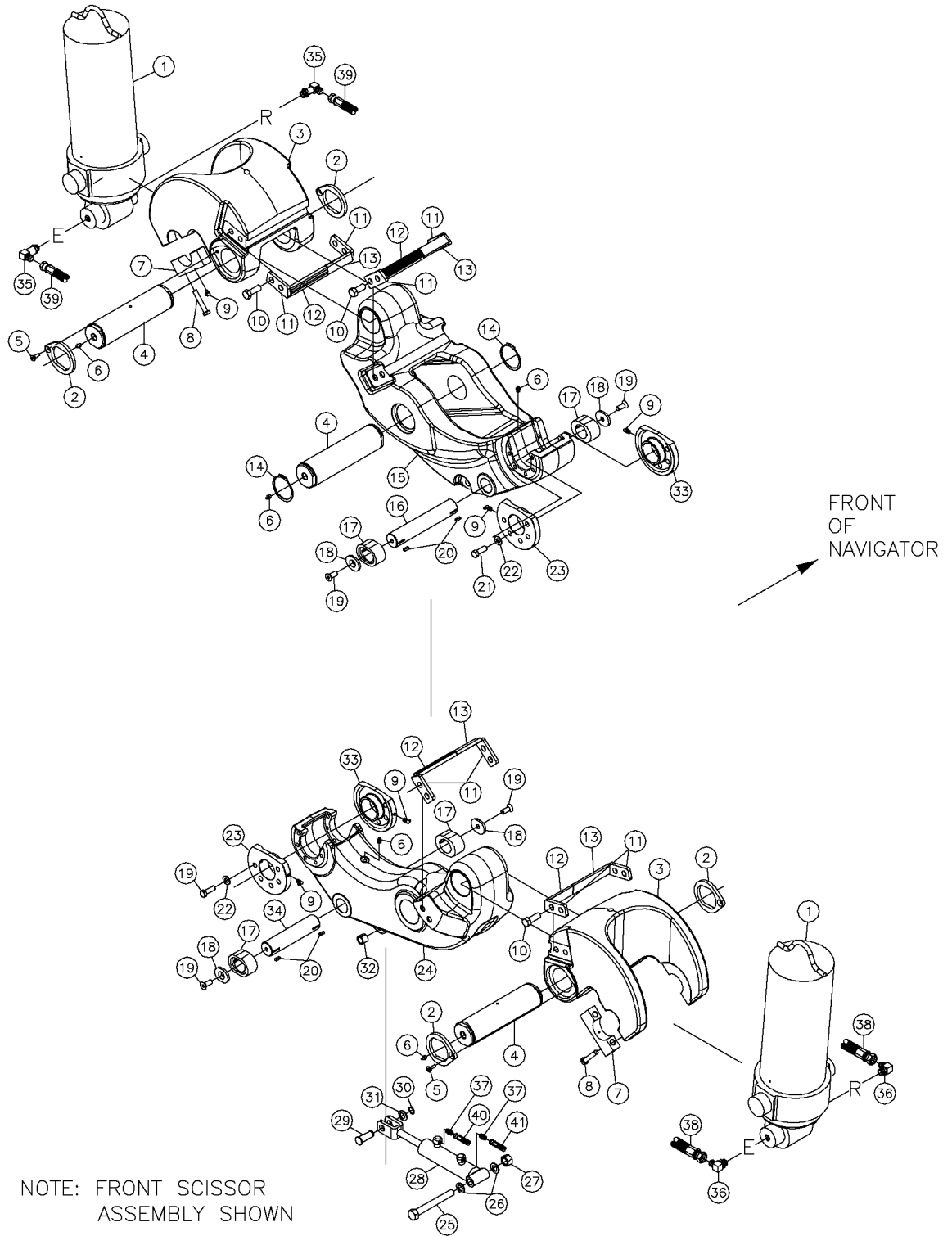

NOTE: FRONT SCISSOR ASSEMBLY SHOWN

Vise Scissor Assy S/N 105 & 107-110 Fig 8-4

REF. NO.	*	PART NO.	DESCRIPTION	QTY.	REMARKS
		Revision Date	June, 2002		Addition To Manual
1		296262568	CYLINDER - 6.5 X 12.75 X 3	2	Breakdown Fig 12-46
2		296261600	PIN LOCK	4	
3		296262567	MACHINING-TONG HEAD	2	
4		296261644	PIN-SIZZOR VISE - 3.00	3	
5		95988010	CAPSCREW-3/8-16X1 FLTHD SOCKET	4	
6		586001	ZERK-1/8" ST NPT GREASE	5	
7		296265254	ENDCAP - TRUNION	4	
8		235744001	BOLT-1/2-13X2 3/4 GR8 ZNC PLTD	8	
9		597001	ZERK-1/4" NF 90 DEG GREASE	8	
10		230727001	BOLT-5/8-11X1 1/2GR8 PLATED	16	
11		296261598	STOP-TONG DIE	8	
12		296252194	TONG DIE 5.88	4	
13		296265255	SPACER-TONG DIE-4.06"	4	
14		600300	SNAP RING-#5100-300	2	
15		296265301	SCISSOR LINK, FEMALE-MACH	1	
16		296261646	DRIVE-PIN-FEMALE	1	
17		296261648	CAM PIN DRIVE	4	
18		296261647	RETAINER-DRIVE PINE	4	
19		231974010	SCREW-1/2-13 X 1 FLT HD SOCKET	4	
20		57703	H KEYS 3/16 X 3/16 X 1	4	
21		235721001	BOLT-1/2-13X1 1/2 GR8 ZINC PLT	20	
22		485025	WASHER-1/2 FLAT-HARDENED-ZINC	20	
23		296261597	RETAINER-TRUNION-LHS	2	
24		296265299	SCISSOR LINK-MALE-MACH	1	
25		385060	BOLT-3/4-10X6 GRADE 8 HEX	1	
26		483001	WASHER - 1 1/4" OD X 3/4" ID - 10 GA MB/YELLOWZINC	2	
27		235739001	NUT-3/4-10 GR8 ZINC PLTD	1	
28		296262569	LIFT CYL - .75 X 1.75 X 3.00 STR	1	Breakbreak Fig 12-42
29		296265304	PIN-LIFT CYLINDER	1	
30		600075	SNAP RING-#5100 EXT.3/4"	1	
31		483025	WASHER-1 1/4X3/4X14 GA M.B.	1	
32		296265305	BUSHING SPLIT .75ID X 1.00 OD X .75	1	
33		296261599	RETAINER-TRUNION-RHS	2	
34		296261650	DRIVE-PIN-MALE	1	
35		278044001	FITTING-90-8MJIC 8MORBA-L	2	
36		53837001	FITTING - 8M O-RING X 8M JIC 90 DEGREE	2	
37		101507001	FITTING-10MORX4MJIC STR.	2	
38		296062001	HOSE-HYD-.50 X 25 8FSJ ST/45 3000PSI	2	
39		296061001	HOSE-HYD-.50 X 15.5 8FSJ ST/45 3000PSI	2	
40		296077001	HOSE-HYD-.25 X 22 3FSJ ST/ST 3000PSI	1	
41		53843183	HOSE-1/4X18 4FS JIC 3000 PSI	1	
		NOTE:	Qty's Listed Are For Only One Scissor Assy		

Vise Drive Frame Assy S/N 111- Fig 8-5r01

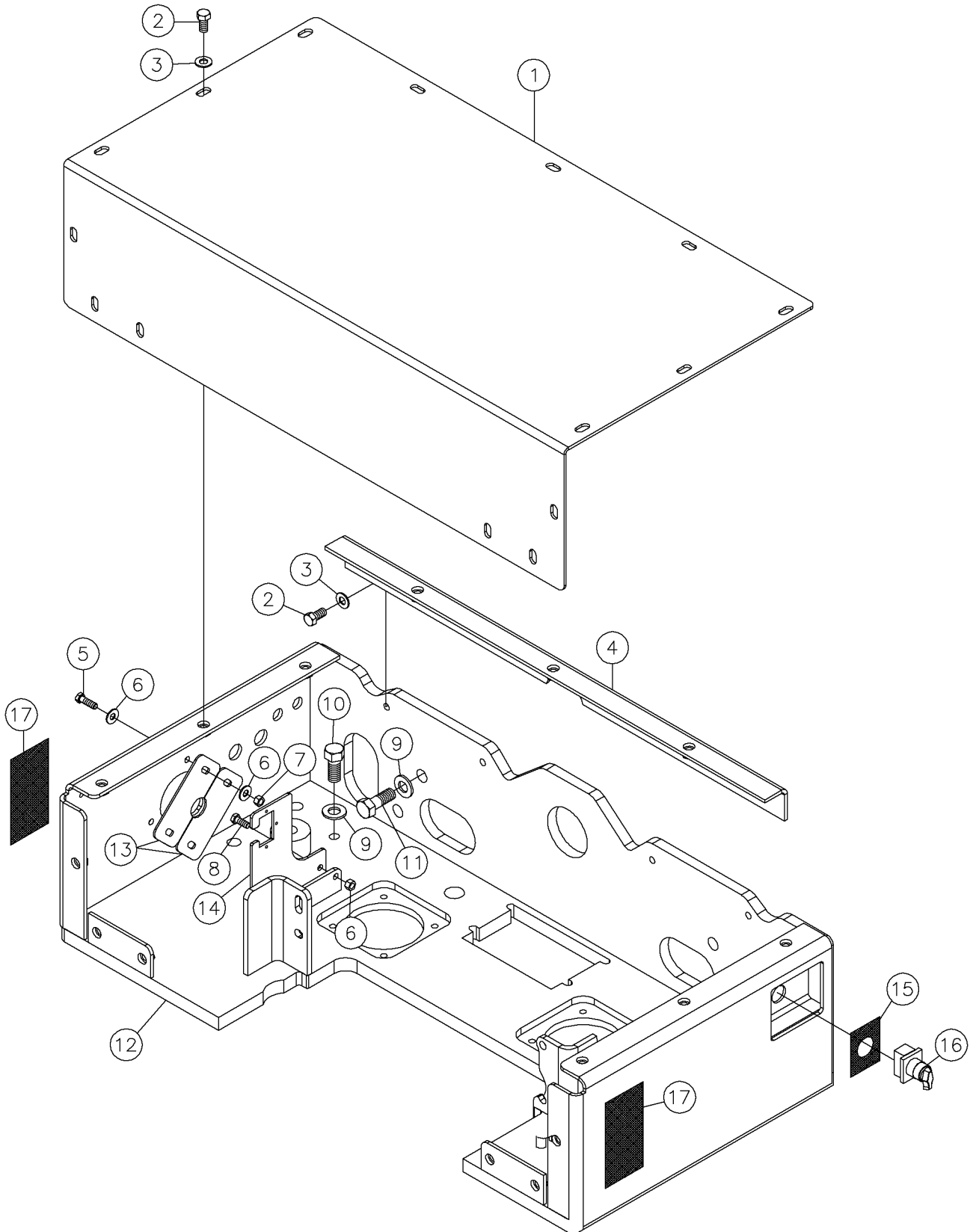

Vise Drive Frame Assy S/N 111- Fig 8-5r01

REF. NO.	*	PART NO.	DESCRIPTION	QTY.	REMARKS
		Revision Date	October, 2004		Update In Illustration & Parts List.
1		296264179	COVER - SCISSOR VISE - D300	1	
2		235729001	SCREW-HCS-.50-13X1.00-GR8-YZ	19	
3		485025	WASHER-1/2 FLAT-HARDENED-YZ	23	
4		296265263	WLDMNT-MNT-VALVE COVER	1	
5		235736001	BOLT-3/8-16X1 1/4 ZINC PLTD	4	
6		510337607	WASHER-FLATSTD-.38-.44X1.00-.08-YZ	8	
7		235725001	NUT - HEX - .38 - 16 - GR8 - YZ	6	
8		235727001	BOLT-3/8-16X1 GR8 HEX ZINC PLT	2	
9		295016001	WASHER, USF CUT IRON	8	
10		243905001	BOLT -3/4-10 X 1 3/4 Gr 8 HEX ZP	4	
11		235746001	BOLT-3/4-10X2 GR8 HEX ZNC PLTD	4	
12		296264129	MACHINE - VISE DRIVE - D300	1	
13		296265311	SPACER-2.00 X 1.31 X 1.00 LONG	2	
14		296265338	MOUNT-WIRE HARNESS	1	
15		700IB751	DECAL - LOCKOUT	1	
16		283177001	SELECTOR SWITCH KIT-LOCAL LOCKOUT	1	
17		700IB811	DECAL - DANGER - RLE INTERNATIONAL	2	International
		7000B811	DECAL - DANGER - RLE - DOMESTIC	2	Domestic

Vise Drive Frame Assy S/N 105 & 107-110 Fig 8-5

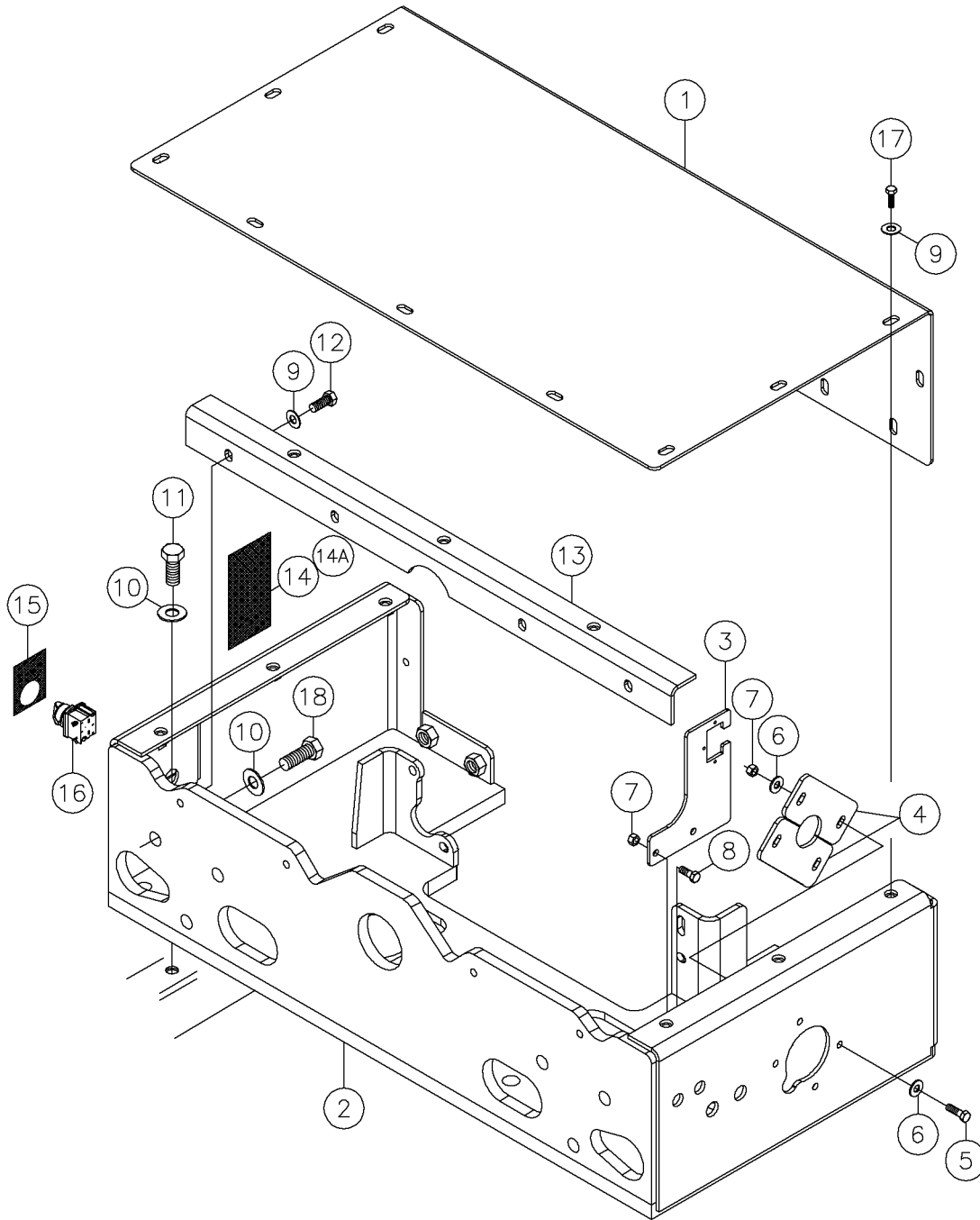

Vise Drive Frame Assy S/N 105 & 107-110 Fig 8-5

REF. NO.	*	PART NO.	DESCRIPTION	QTY.	REMARKS
		Revision Date	June, 2002		Addition To Manual
1		296265288	COVER-VALVE	1	
2		296261622	WISE-DRIVE-MACHINE	1	
3		296265338	MOUNT-WIRE HARNESS	1	
4		296265337	PLATE-GROMMET	2	
5		235736001	BOLT-3/8-16X1 1/4 ZINC PLTD	4	
6		510337607	WASHER-FLATSTD-.38-.44X1.00-.08-YZ	8	
7		235725001	NUT-3/8-16 GR8 ZINC PLTD	6	
8		235727001	BOLT-3/8-16X1 GR8 HEX ZINC PLT	2	
9		485025	WASHER-1/2 FLAT-HARDENED-ZINC	22	
10		295016001	WASHER, SAE FLAT 3/4	10	
11		243905001	BOLT -3/4-10 X 1 3/4 GR 8 HEX ZP	4	
12		235737001	BOLT-1/2-13X1 1/4 GR8 ZINC PLT	7	
13		296265263	WELDMENT-MNT-VALVE COVER	1	
14		7000B811	DECAL - DANGER - RLE - DOMESTIC	1	Domestic
14A		700IB811	DECAL - DANGER - RLE INTERNATIONAL	1	International
15		700IB751	DECAL - LOCKOUT	1	
16		283177001	SELECTOR SWITCH KIT-LOCAL LOCKOUT	1	
17		235729001	SCREW-HCS-.50-13X1.00-GR8-YZ	15	
18		235746001	BOLT-3/4-10X2 GR8 HEX ZNC PLTD	6	

Vise Spread Cylinder Assy S/N 111- Fig 8-6r01

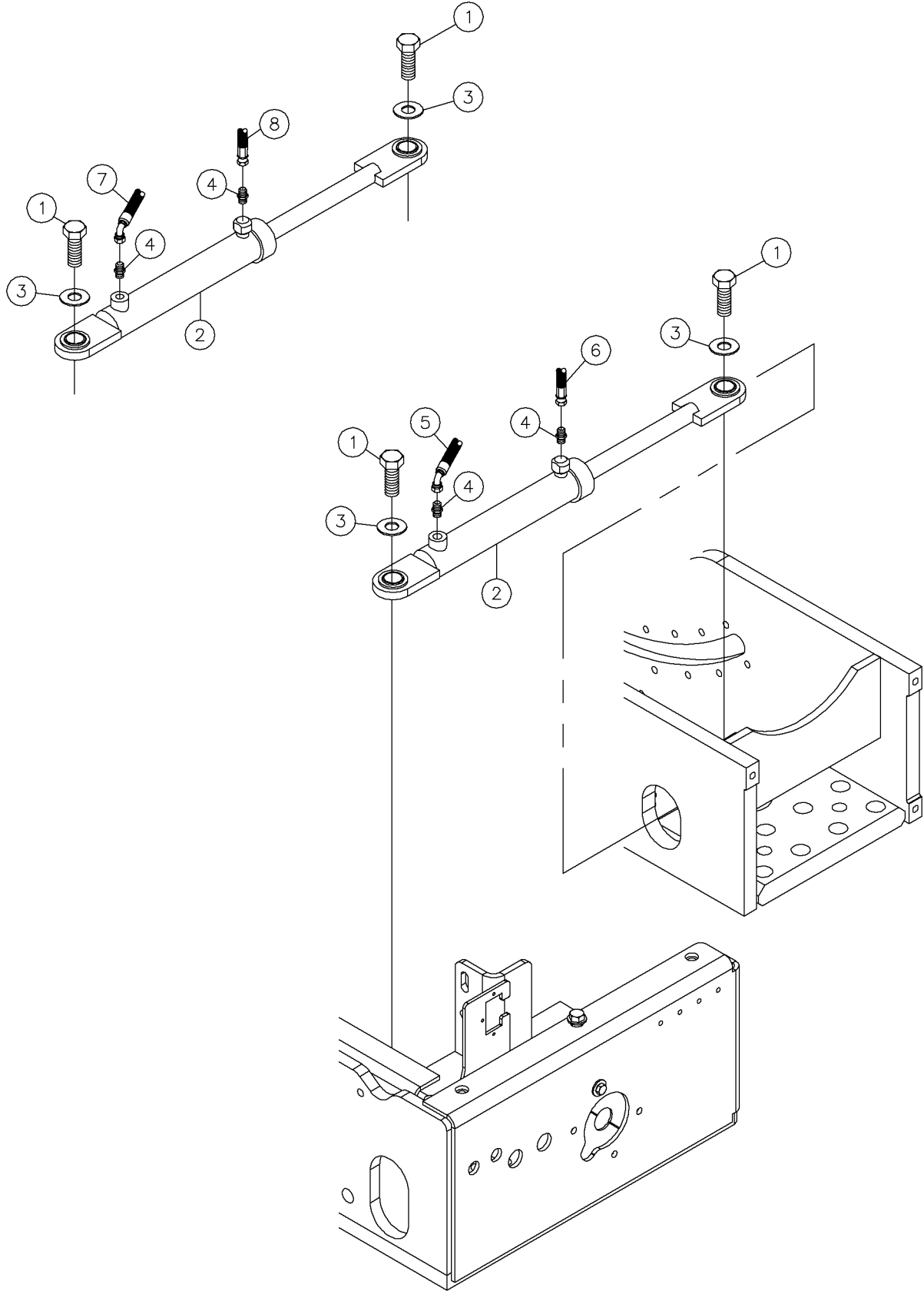

Vise Spread Cylinder Assy S/N 111- Fig 8-6r01

REF. NO.	*	PART NO.	DESCRIPTION	QTY.	REMARKS
		Revision Date	October, 2004		Update In Illustration & Parts List.
1		235746001	BOLT-3/4-10X2 GR8 HEX ZNC PLTD	4	
2		296264126	HYD CYL - 1.5" X 8" STR	2	breakdown Fig 12-43r01
3		295016001	WASHER, USF CUT IRON	4	
4		60908001	FITTING-4MX4M JIC STR ADAPTER	4	
5		296259056	HOSE-HYD-.25 X 23 4FSJ ST/45 3000 PSI	1	
6		296072001	HOSE-HYD-.25 X 31.5 4FSJ ST/90 3000PSI	1	
7		296256898	HOSE - .25 X 17 4 FS JIC 45/ST M3K	1	
8		296071001	HOSE-HYD-.25 X 24 4FSH ST/ST 3000PSI	1	

Vise Spread Cylinder Assy S/N 105 & 107-110 Fig 8-6

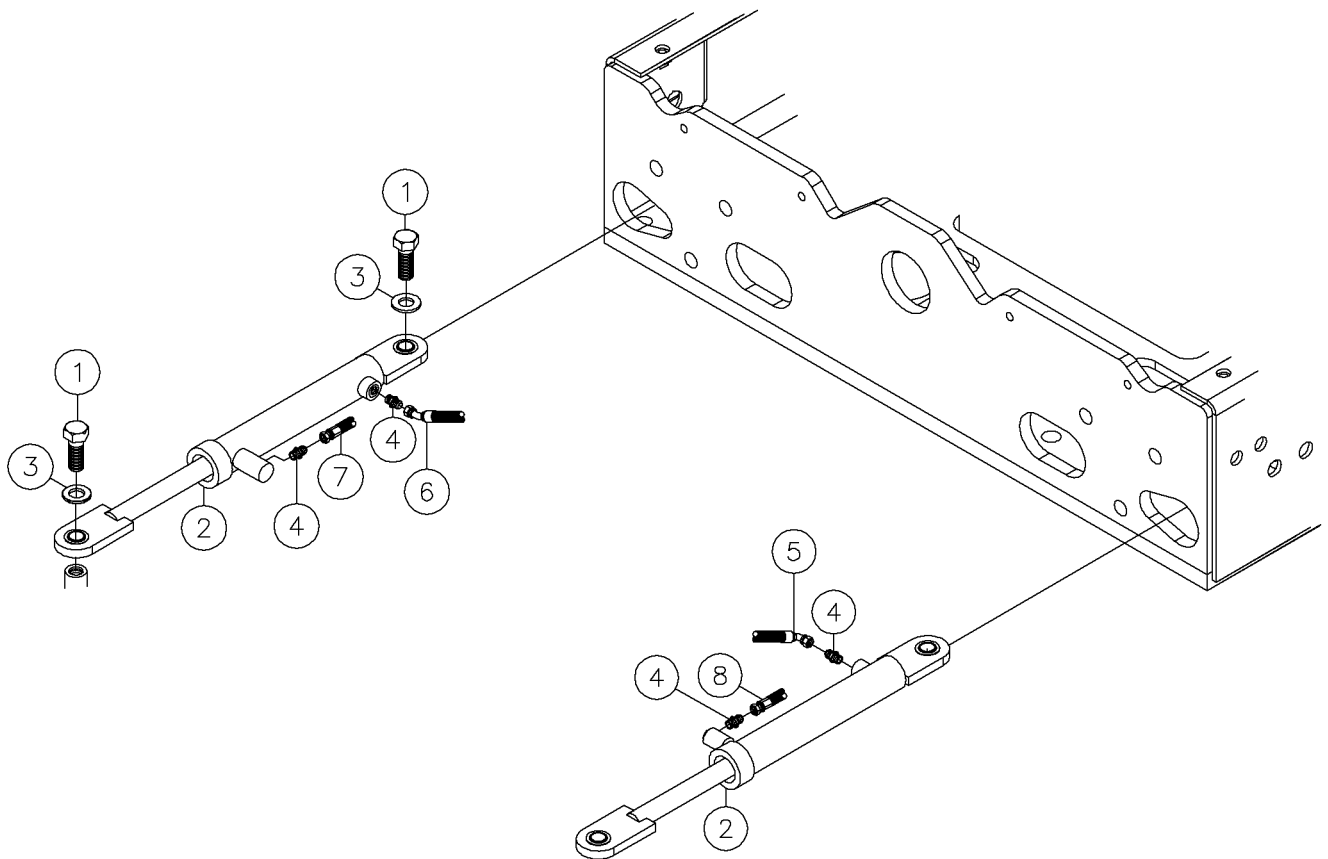

Vise Spread Cylinder Assy S/N 105 & 107-110 Fig 8-6

REF. NO.	*	PART NO.	DESCRIPTION	QTY.	REMARKS
		Revision Date	June, 2002		Addition To Manual
1		235746001	BOLT-3/4-10X2 GR8 HEX ZNC PLTD	4	
2		296265251	HYD CYL-1.5" X 8" STR	2	Breakdown Fig. 12-43
3		295016001	WASHER, SAE FLAT 3/4	4	
4		60908001	FITTING-4MX4M JIC STR ADAPTER	4	
5		296256898	HOSE - .25 X 17 4 FS JIC 45/ST M3K	1	
6		296259056	HOSE - .25 X 23 4 FS JIC 45/ST M3K	1	
7		296072001	HOSE-.25X31.5-4FSJ ST/90-3000 PSI	1	
8		296071001	HOSE-HYD-.25 X 24 4FSH ST/ST 3000PSI	1	

Vise Travel Motor Assy S/N 111- Fig 8-7r01

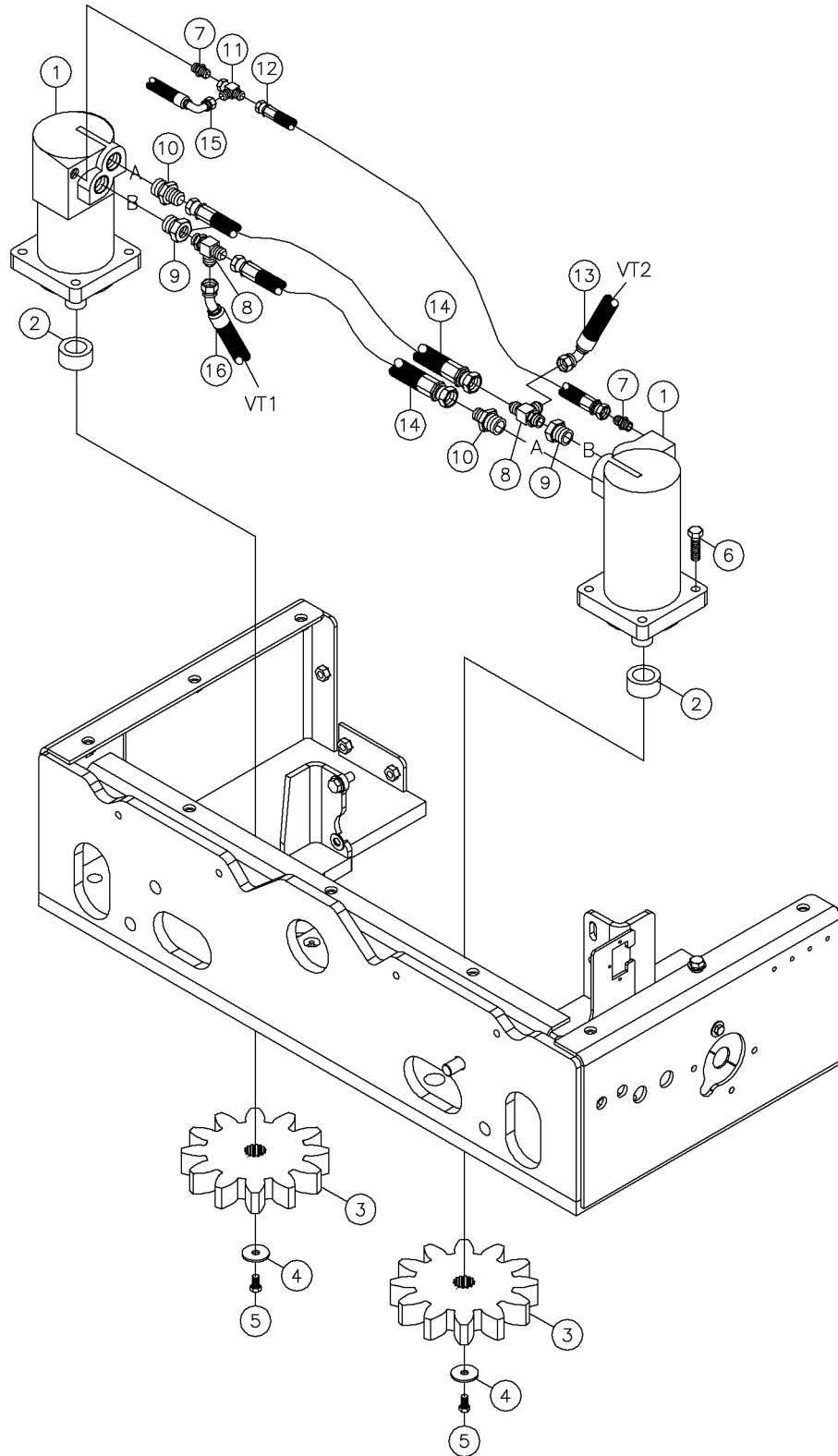

Vise Travel Motor Assy S/N 111- Fig 8-7r01

REF. NO.	*	PART NO.	DESCRIPTION	QTY.	REMARKS
		Revision Date	October, 2004		Update In Illustration & Parts List.
1		296265253	HYD MOTOR - 4K-38CIR-SAE C	2	Breakdown Fig 12-47
2		296265311	SPACER-2.00 X 1.31 X 1.00 LONG	2	
3		277865001	PINION - 16 MODULE 12T - 1.5" FACE	2	
4		277377001	WASHER - 3/8 LARGE OD CASE HARDENED	2	
5		235726001	BOLT-3/8-16X3/4 GR8 HEX ZNCPLT	2	
6		240334001	BOLT-1/2-13X1 3/4 GR8 ZINC PLT	8	
7		65565001	FITTING - 6M O-RING X 6M JIC ST.	2	
8		81705001	FITTING-8MX8M JIC(RUN)X8M JIC	2	
9		81702001	FITTING - STR - 12MORB - 8FORB	2	
10		53825001	#12M O-RING-#8M JIC ST.	2	
11		59427001	TEE-6MJ-6FSJ-6MJ	1	
12		296066001	HOSE-HYD-.38 X 18 6FSJ ST/ST 3000PSI	1	
13		296064001	HOSE-HYD-.50 X 18 8FSJ90/90-90 ORIENT	1	
14		296065001	HOSE -HYD-.50 X9.75 8FSJ ST/ST 3000PSI	2	
15		278800001	HOSE-3/8X23 6FSJIC ST/90 M3K	1	
16		296063001	HOSE-HYD-.50 X 10 8FSJ ST/45 3000PSI	1	

Vise Travel Motor Assy S/N 105 & 107-110 Fig 8-7

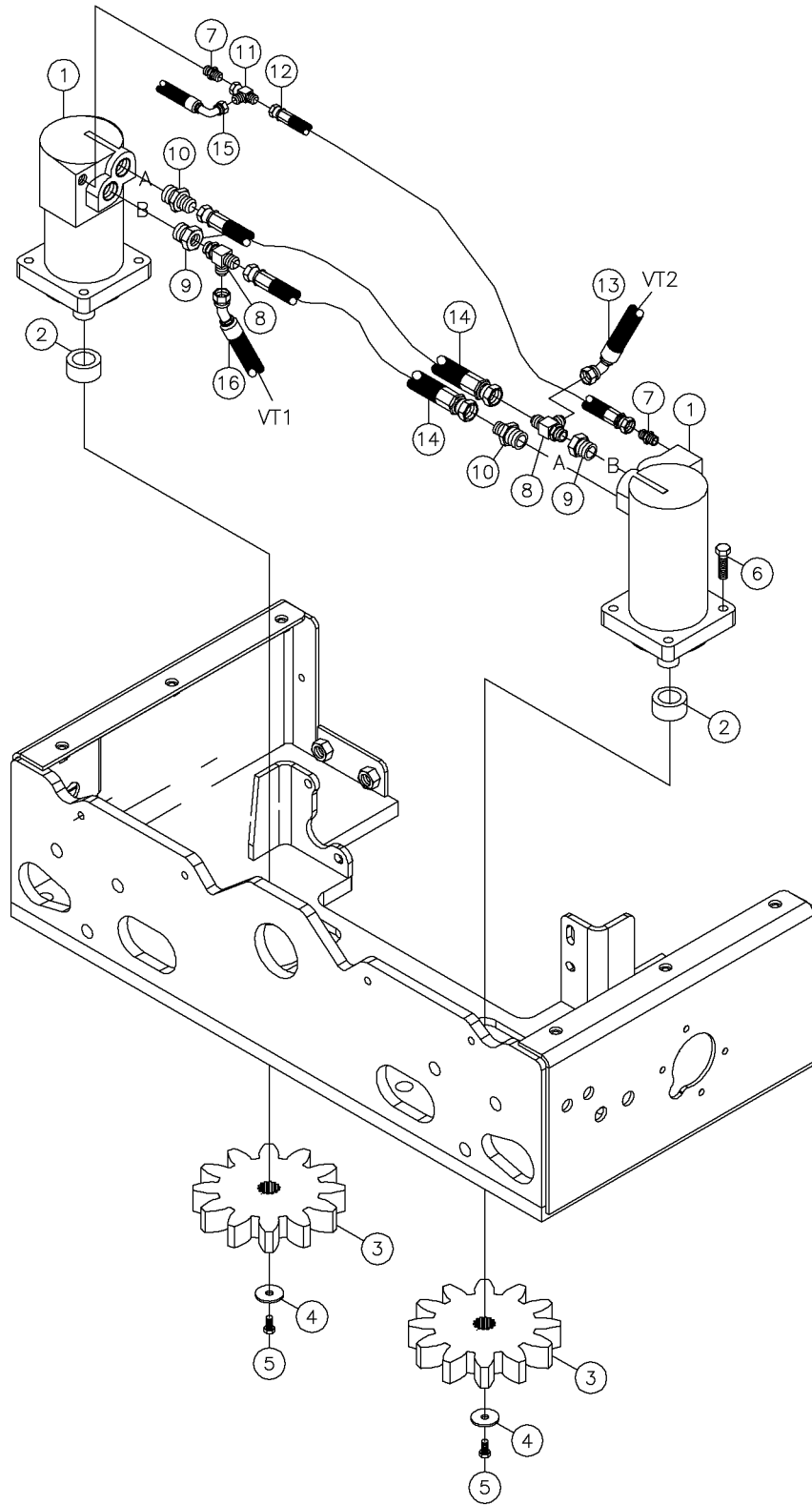

Vise Travel Motor Assy S/N 105 & 107-110 Fig 8-7

REF. NO.	*	PART NO.	DESCRIPTION	QTY.	REMARKS
		Revision Date	June, 2002		Addition To Manual
1		296265253	HYD MOTOR - 4K-38- CIR-'C XYX	2	Breakdown Fig 12-47
2		296265311	SPACER-2.00 X 1.31 X 1.00 LONG	2	
3		277865001	PINION - 16 MODEULE - 12T - 1.5" FACE	2	
4		277377001	WASHER - 3/8 LARGE OD CASE HARDENED	2	
5		235726001	BOLT-3/8-16X3/4 GR8 HEX ZNCPLT	2	
6		240334001	BOLT-1/2-13X1 3/4 GR8 ZINC PLT	8	
7		65565001	FITTING - 6M O-RING X 6M JIC ST.	2	
8		81705001	FITTING-8MX8M JIC(BCH)X8M JIC	2	
9		81702001	FITTING-12MX8F STR.	2	
10		53825001	#12M O-RING-#8M JIC ST.	2	
11		59427001	TEE-6M JIC BCH 6FS JIC X6M JIC	1	
12		296066001	HOSE-HYD-.38 X 18 6FSJ ST/ST 3000PSI	1	
13		296064001	HOSE-HYD-.50 X 18 8FSJ 90/90 3000PSI	1	
14		296065001	HOSE -HYD-.50 X9.75 8FSJ ST/ST 3000PSI	2	
15		278800001	HOSE-3/8X23 6FSJIC ST/90 M3K	1	
16		296063001	HOSE-HYD-.50 X 10 8FSJ ST/45 3000PSI	1	

Vise Clamp Valve Assy S/N 111- Fig 8-8r01

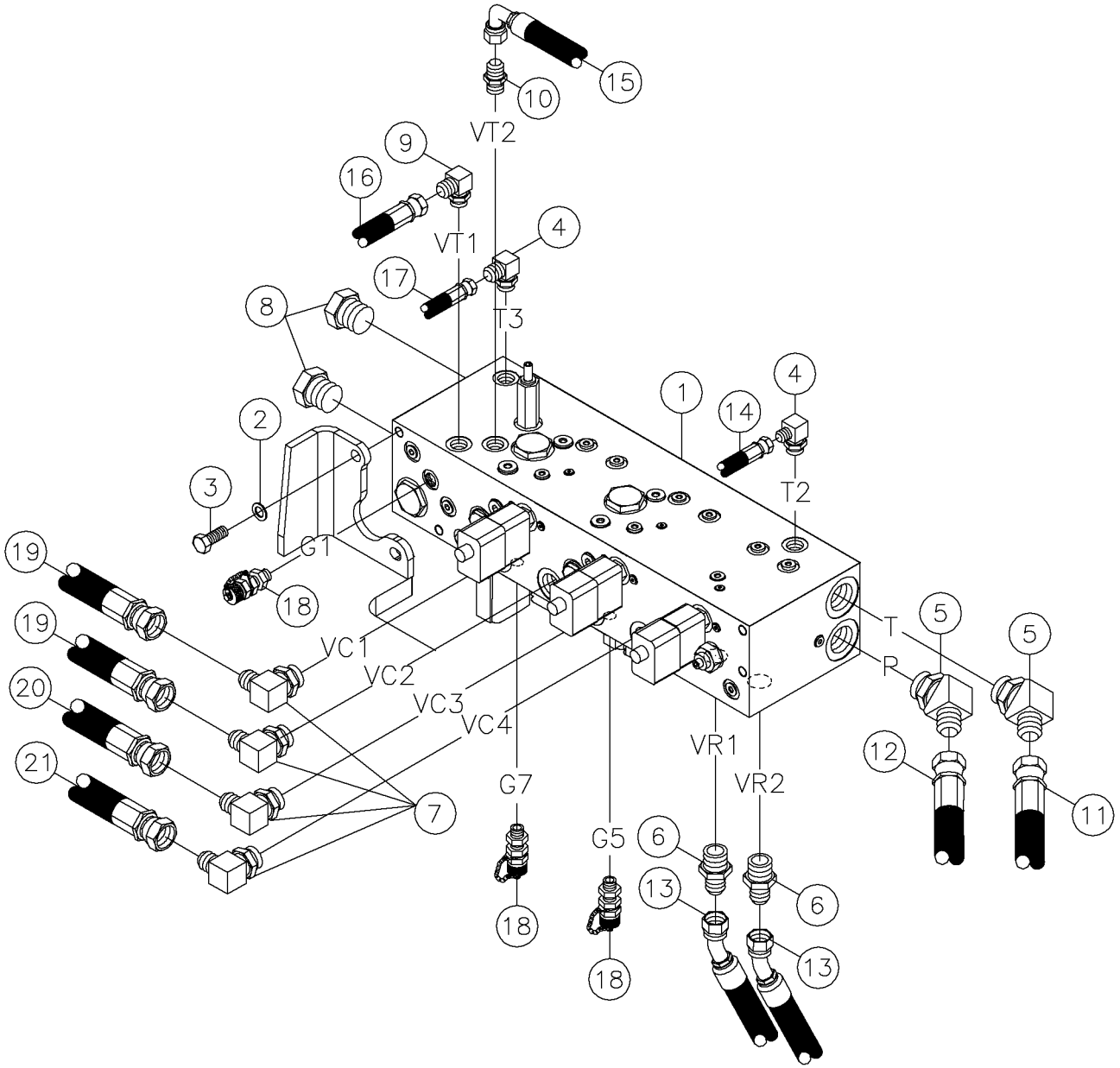

Vise Clamp Valve Assy S/N 111- Fig 8-8r01

REF. NO.	*	PART NO.	DESCRIPTION	QTY.	REMARKS
		Revision Date	October, 2004		Update In Illustration & Parts List.
1		296265316	HYD VALVE-sCISSOR VISE-CLAMP	1	Breakdown Fig 12-45r01
2		485025	WASHER-1/2 FLAT-HARDENED-ZINC	4	
3		235737001	BOLT-1/2-13X1 1/4 GR8 ZINC PLT	4	
4		57954001	FITTING-8M X 6M JIC 90 DEGS	2	
5		129482001	FIT-12MJICX16MO'RING45DEG MACH	2	
6		53854001	FITTING-12M O-RING-10M JIC ST.	2	
7		59409001	FITTING-10M JICX12M ADJ. 90 DEG.ELBOW	4	
8		81214001	PLUG- 16M	2	
9		904681001	FITTING-8MX8MJIC-90 SWIVEL	1	
10		53824001	FITTING-#8M O-RING-#8M JIC ST.	1	
11		296051001	HOSE-HYD-.75X 21 12FSJ ST/90 3000PSI	1	
12		296052001	HOSE-HYD-.75X18.5 12FSJ ST/ST 3000PSI	1	
13		275125001	HOSE-5/8X23 10FSJIC ST/45 M3K	2	
14		296055001	HOSE-HYD-.38 X 28 6FSJ ST/45 3000PSI	1	
15		296064001	HOSE-HYD-.50 X 18 8FSJ 90/90 3000PSI	1	
16		296063001	HOSE-HYD-.50 X 10 8FSJ ST/45 3000PSI	1	
17		278800001	HOSE-3/8X23 6FSJIC ST/90 M3K	1	
18		72056001	FITTING-TEST-6MORB-16MTP	3	
19		53842489	HOSE 5/8X27 10FSJICST 3000PSI	2	
20		296060001	HOSE-HYD-.63 X 30.5 10FSJ ST/90 3000PSI	1	
21		296259057	HOSE-HYD-10X26.5-10FSJ ST/90-3000PSI	1	

Vise Clamp Valve Assy S/N 105 & 107-110 Fig 8-8

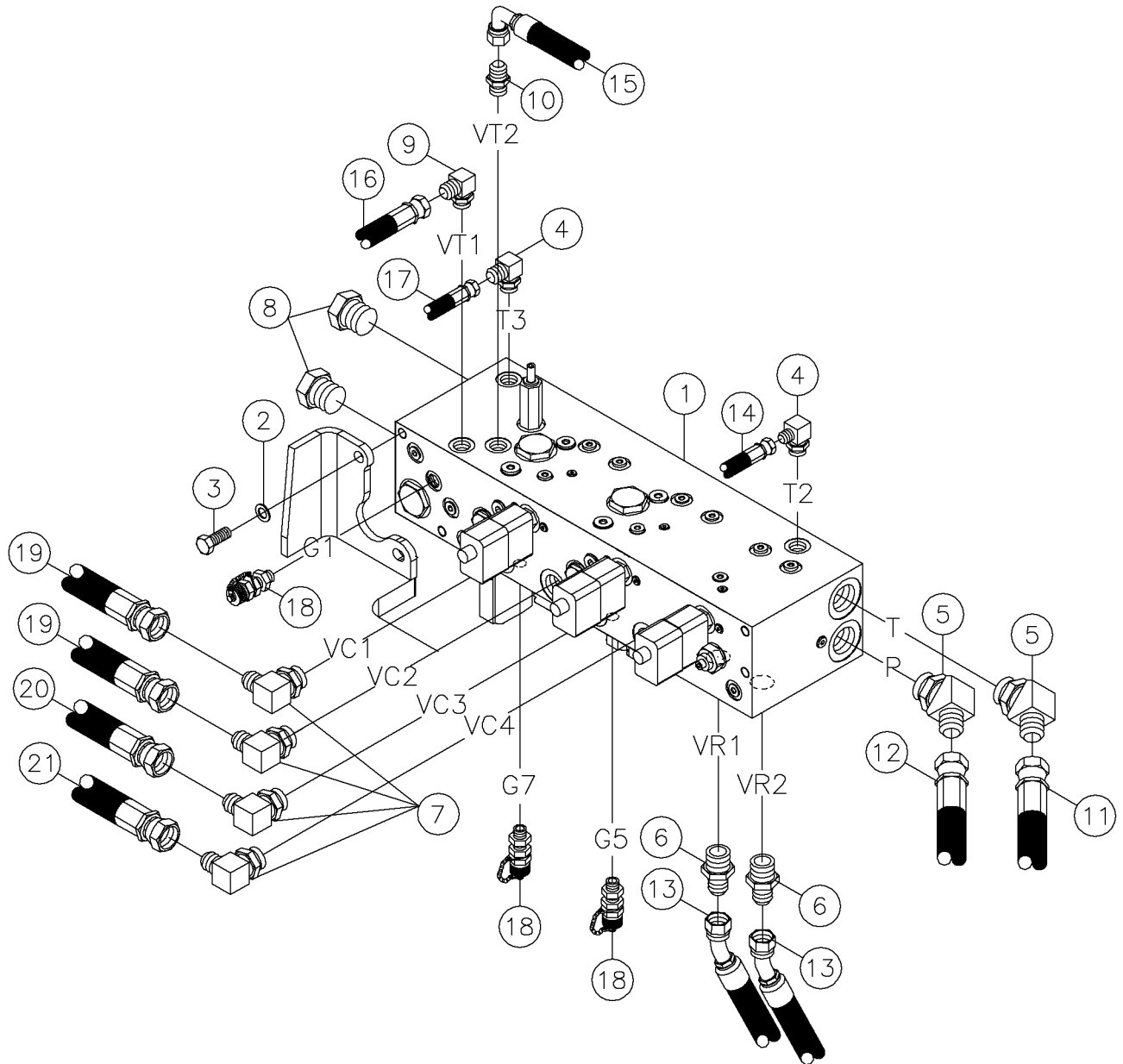

Vise Clamp Valve Assy S/N 105 & 107-110 Fig 8-8

REF. NO.	*	PART NO.	DESCRIPTION	QTY.	REMARKS
		Revision Date	June, 2002		Addition To Manual
1		296265316	HYD VALVE-sCISSOR VISE-CLAMP	1	Breakdown Fig 12-45
2		485025	WASHER-1/2 FLAT-HARDENED-ZINC	4	
3		235737001	BOLT-1/2-13X1 1/4 GR8 ZINC PLT	4	
4		57954001	FITTING-8M X 6M JIC 90 DEGS	2	
5		129482001	FIT-12MJICX16MO'RING45DEG MACH	2	
6		53854001	FITTING-12M O-RING-10M JIC ST.	2	
7		59409001	FITTING-10M JICX12M ADJ. 90 DEG.ELBOW	4	
8		81214001	PLUG- 16M	2	
9		904681001	FITTING-8MX8MJIC-90 SWIVEL	1	
10		53824001	FITTING-#8M O-RING-#8M JIC ST.	1	
11		296051001	HOSE-HYD-.75X 21 12FSJ ST/90 3000PSI	1	
12		296052001	HOSE-HYD-.75X18.5 12FSJ ST/ST 3000PSI	1	
13		275125001	HOSE-5/8X23 10FSJIC ST/45 M3K	2	
14		296055001	HOSE-HYD-.38 X 28 6FSJ ST/45 3000PSI	1	
15		296064001	HOSE-HYD-.50 X 18 8FSJ 90/90 3000PSI	1	
16		296063001	HOSE-HYD-.50 X 10 8FSJ ST/45 3000PSI	1	
17		278800001	HOSE-3/8X23 6FSJIC ST/90 M3K	1	
18		72056001	FITTING-TEST-6MORB-16MTP	3	
19		53842489	HOSE 5/8X27 10FSJICST 3000PSI	2	
20		296060001	HOSE-HYD-.63 X 30.5 10FSJ ST/90 3000PSI	1	
21		296259057	HOSE-HYD-10X26.5-10FSJ ST/90-3000PSI	1	

Vise Lift Valve Assy S/N 111- Fig 8-9r01

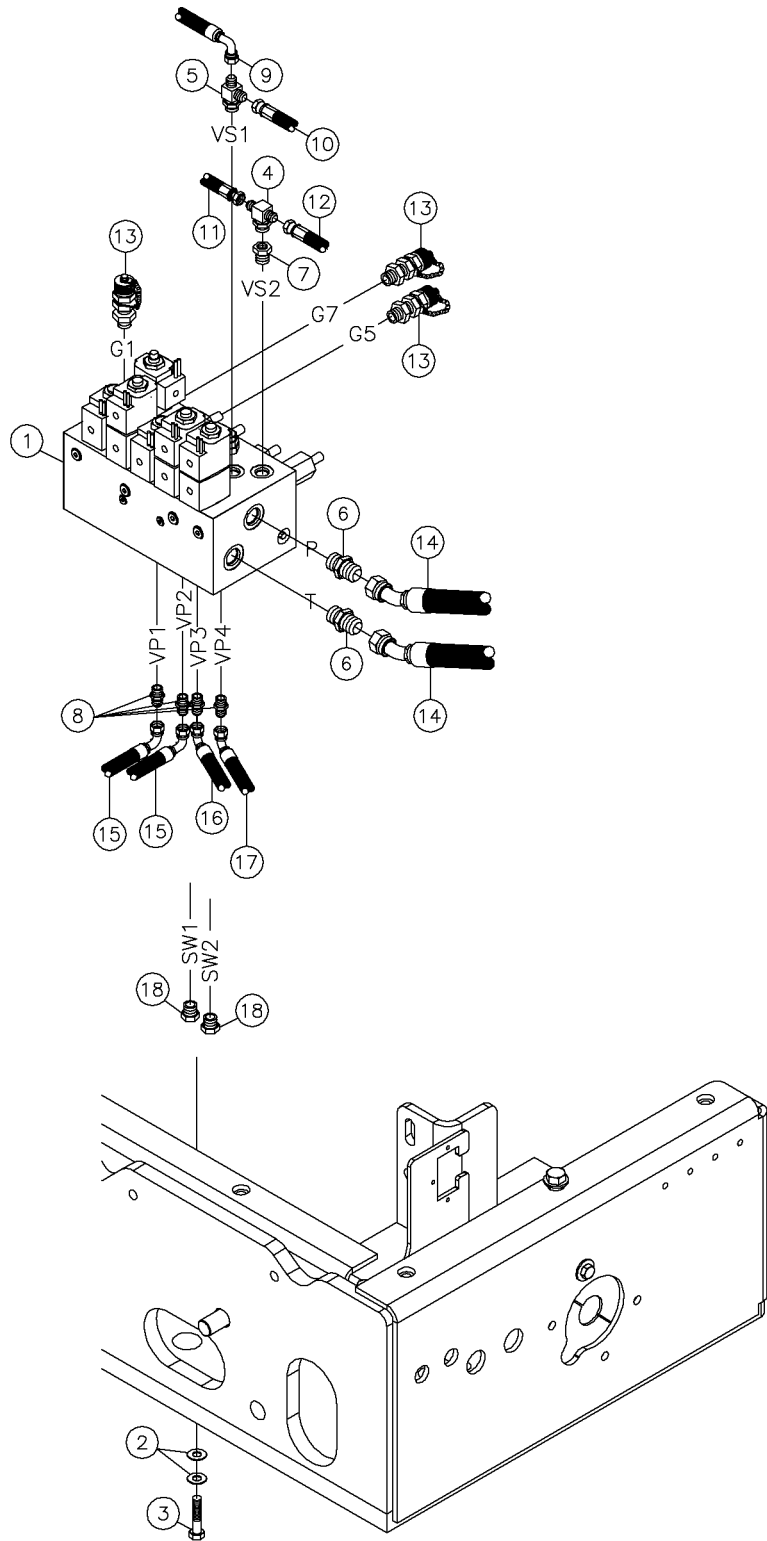

Vise Lift Valve Assy S/N 111- Fig 8-9r01

REF. NO.	*	PART NO.	DESCRIPTION	QTY.	REMARKS
		Revision Date	October, 2004		Update In Illustration & Parts List.
1		296256317	HYD VALVE-SCISSOR VISE-LIFT	1	Breakdownm Fig 12-44
2		510337607	WASHER-FLATSTD-.38-.44X1.00-.08-YZ	4	
3		235720001	BOLT-3/8-16X1 3/4 6R8 ZINC PLT	4	
4		81343001	FITTING-4M (BCH)X4M JICX4M JIC TEE	1	
5		82930001	FIT-6MX4M JICX4M JIC (BCH) TEE	1	
6		53824001	FITTING-#8M O-RING-#8M JIC ST.	2	
7		67291001	FITTING-6MX4F SOLID REDUCER	1	
8		57968001	FITTING-STR-4MJ-6MORB	4	
9		296072001	HOSE-HYD-.25 X 31.5 4FSJ ST/90 3000PSI	1	
10		296071001	HOSE-HYD-.25 X 24 4FSH ST/ST 3000PSI	1	
11		296259056	HOSE-.25X23-4FSJIC ST/45-3000PSI	1	
12		296256898	HOSE - .25 X 17 4 FS JIC 45/ST M3K	1	
13		72056001	FITTING-TEST-6MORB-16MTP	3	
14		296069001	HOSE-HYD-.50 X 18.0 8FSJ ST/45 3000PSI	2	
15		296073001	HOSE-HYD-.25 X 17.5 4FSJ ST/90 3000PSI	2	
16		296078001	HOSE-HYD-.25 X18.5 4FSJ ST/45 3000PSI	1	
17		296079001	HOSE-HYD-.25 X 14.5 4FSJ ST/45 3000 PSI	1	
18		5553001	FITTING - PLUG - 6MORB - HEX	2	

Vise Lift Valve Assy S/N 105 & 107-110 Fig 8-9

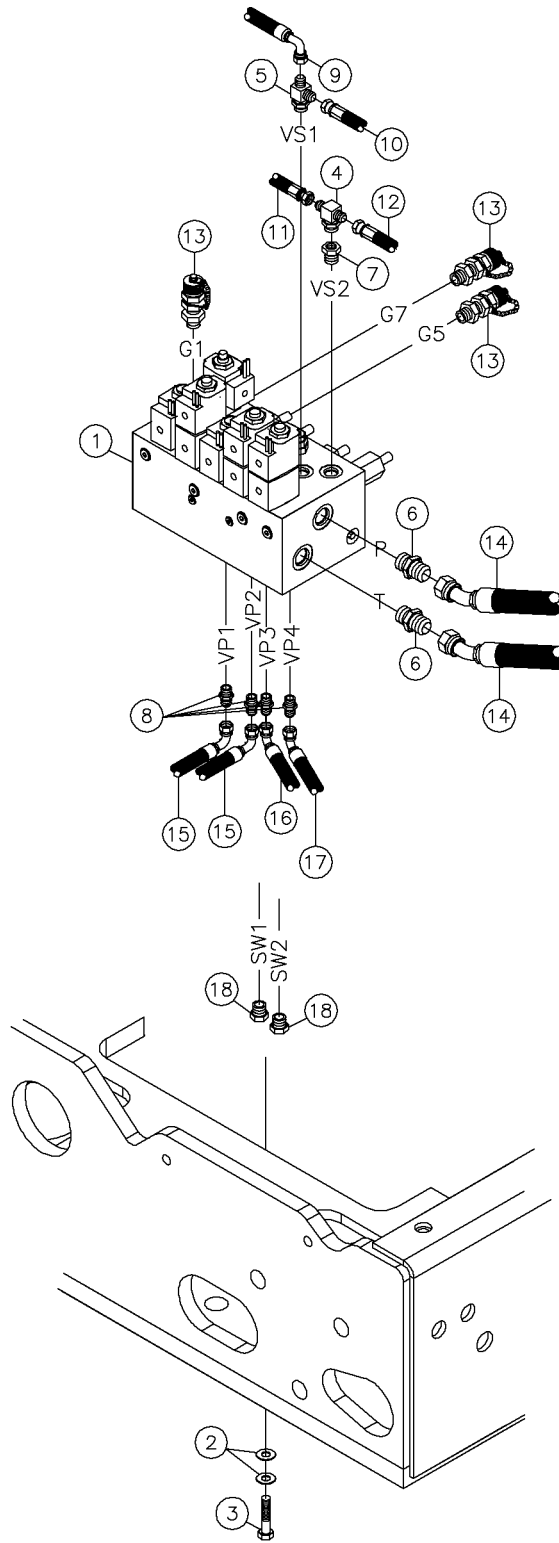

Vise Lift Valve Assy S/N 105 & 107-110 Fig 8-9

REF. NO.	*	PART NO.	DESCRIPTION	QTY.	REMARKS
		Revision Date	June, 2002		Addition To Manual
1		296256317	HYD VALVE-SCISSOR VISE-LIFT	1	Breakdownm Fig 12-44
2		510337607	WASHER-FLATSTD-.38-.44X1.00-.08-YZ	4	
3		235720001	BOLT-3/8-16X1 3/4 6R8 ZINC PLT	4	
4		81343001	FITTING-4M (BCH)X4M JICX4M JIC TEE	1	
5		82930001	FIT-6MX4M JICX4M JIC (BCH) TEE	1	
6		53824001	FITTING-#8M O-RING-#8M JIC ST.	2	
7		67291001	FITTING-6MX4F SOLID REDUCER	1	
8		57968001	FITTING-STR-4MJ-6MORB	4	
9		296072001	HOSE-HYD-.25 X 31.5 4FSJ ST/90 3000PSI	1	
10		296071001	HOSE-HYD-.25 X 24 4FSH ST/ST 3000PSI	1	
11		296259056	HOSE-.25X23-4FSJIC ST/45-3000PSI	1	
12		296256898	HOSE - .25 X 17 4 FS JIC 45/ST M3K	1	
13		72056001	FITTING-TEST-6MORB-16MTP	3	
14		296069001	HOSE-HYD-.50 X 18.0 8FSJ ST/45 3000PSI	2	
15		296073001	HOSE-HYD-.25 X 17.5 4FSJ ST/90 3000PSI	2	
16		296078001	HOSE-HYD-.25 X18.5 4FSJ ST/45 3000PSI	1	
17		296079001	HOSE-HYD-.25 X 14.5 4FSJ ST/45 3000 PSI	1	
18		5553001	FITTING - PLUG - 6MORB - HEX	2	

Vise Scissor Rotation Assy S/N 111- Fig 8-10r01

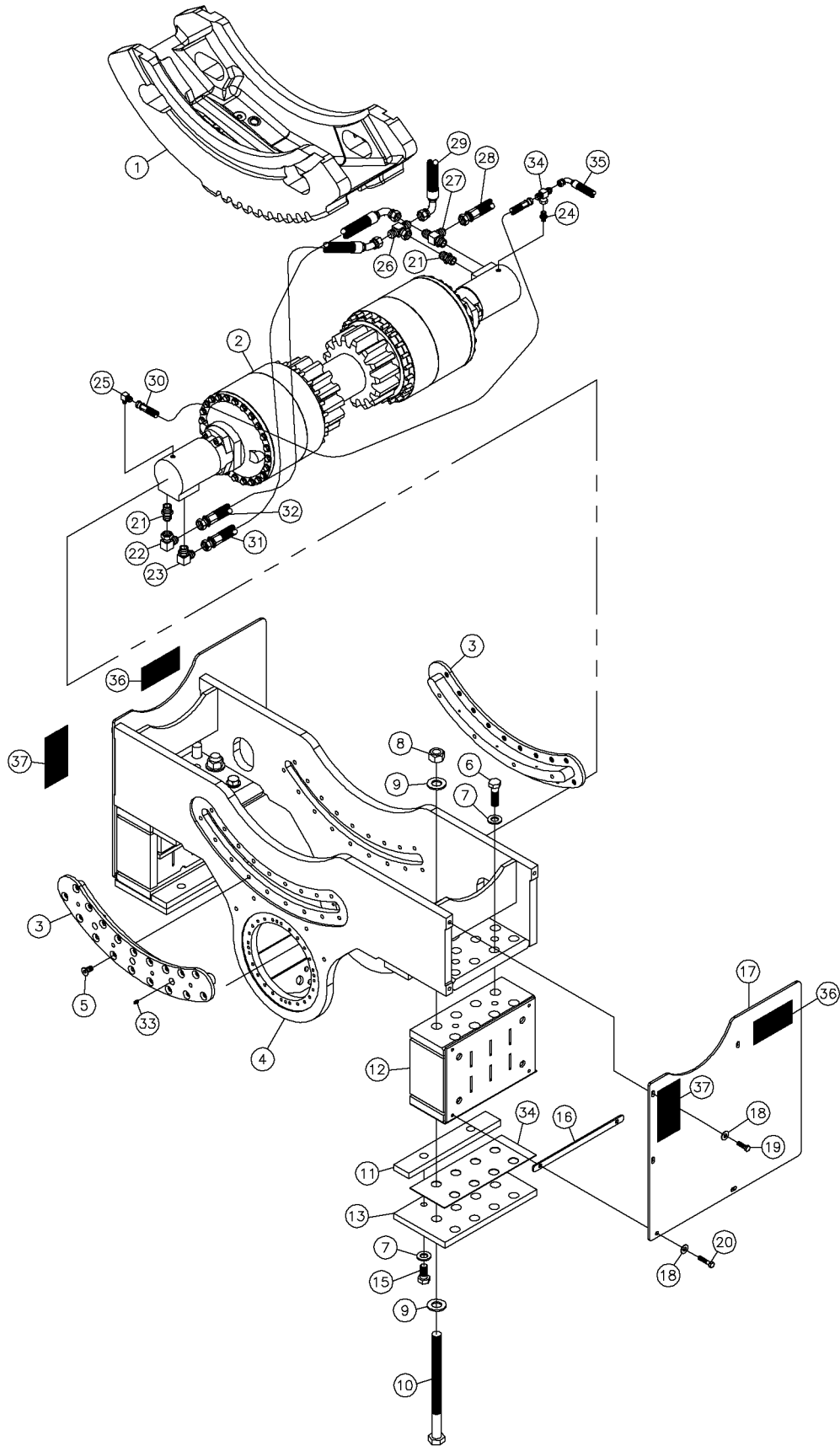

Vise Scissor Rotation Assy S/N 111- Fig 8-10r01

REF. NO.	*	PART NO.	DESCRIPTION	QTY.	REMARKS
		Revision Date	October, 2004		Update In Illustration & Parts List.
1		296264101	DRIVE GEAR - SCISSORS VISE - 2 D.P.	1	
2		296264084	ASSY - TWIN G.B. DRIVE	1	Breakdown Fig 8-12r01
3		296261651	WEAR RING-SCISSOR VISE	2	
4		296264106	REAR VISE - MACHINE - D300	1	
5		231974010	SCREW-1/2-13 X 1 FLT HD SOCKET	36	
6		238880001	BOLT-3/4-10X2 1/2 HHCS GR8 ZY	4	
7		295016001	WASHER, USF CUT IRON	8	
8		296264185	NUT - HEX - 1.00-14-GR8-YZ	16	
9		238892001	WASHER-1" HARDENED FLAT ZY	32	
10		296264183	SCREW-HCS-1.00-14-UNSX13.25-GR8-YZ-RLD	16	
11		296264124	WEAR PAD - NYLATRON .75 X 2.25 X 13.75	2	
12		296264112	MACHINE - BRIDGE UPPER	2	
13		296264122	RETAINER PLATE - VISE BRIDGE	2	
14		296264123	SHIM - VISE BRIDGE UPPER	2	
15		238217001	BOLT-3/4-10X1 1/2 GR8 HEX ZYC	4	
16		296264181	SHIM/VISE GUARD	2	
17		296264182	VISE - GUARD	2	
18		235736001	BOLT-3/8-16X1 1/4 ZINC PLTD	10	
19		510337607	WASHER-FLATSTD-.38-.44X1.00-.08-YZ	10	
20		235720001	BOLT-3/8-16X1 3/4 6R8 ZINC PLT	4	
21		53827001	FITT.-#10M O-RING-#10M JIC ST.	2	
22		61694001	10M JIC X 10FS JIC 90	1	
23		53829001	#10M O-RING-#10M JIC 90 DEG.	1	
24		65569001	4M X 6M JIC ST.	2	
25		60906001	4MX6M JIC 90 DEG ELBOW	1	
26		98947001	TEE-10M BCHX10MJICX10MJIC	1	
27		100872001	FITTING-10FSJICX10MJIC RUN TEE	1	
28		257511001	HOSE-HYD-.63X37-10FSJ-ST/90-M3KMTF	1	
29		296053001	HOSE-HYD-.63 X 36 10FSJ 90/90-90 ORIENT	1	
30		57940721	HOSE-3/8X63 6FSJICST 3000 PSI	1	
31		162671001	HOSE-HYD-.62X50-10FSJ-10FSJ90-3000PSI	1	
32		263904001	HOSE HYD 5/8 X 52 10FS-STX10FS-45	1	
33		598001	FITTING-1/4" NF ST GREASE ZERK	6	
34		60852001	6M JICX6FS JIC SWIV.NUT B TEE	1	
35		296054001	HOSE-HYD-.38 X 36 6FSJ 90/90 270 ORIENT	1	
36		7000B839	DECAL - WARNING	2	Domestic
		700IB839	DECAL - WARNING	2	International
37		7000A393	DECAL - DANGER	2	Domestic
		700IA393	DECAL - DANGER	2	International

Vise Scissor Rotation Assy S/N 105 & 107-110 Fig 8-10

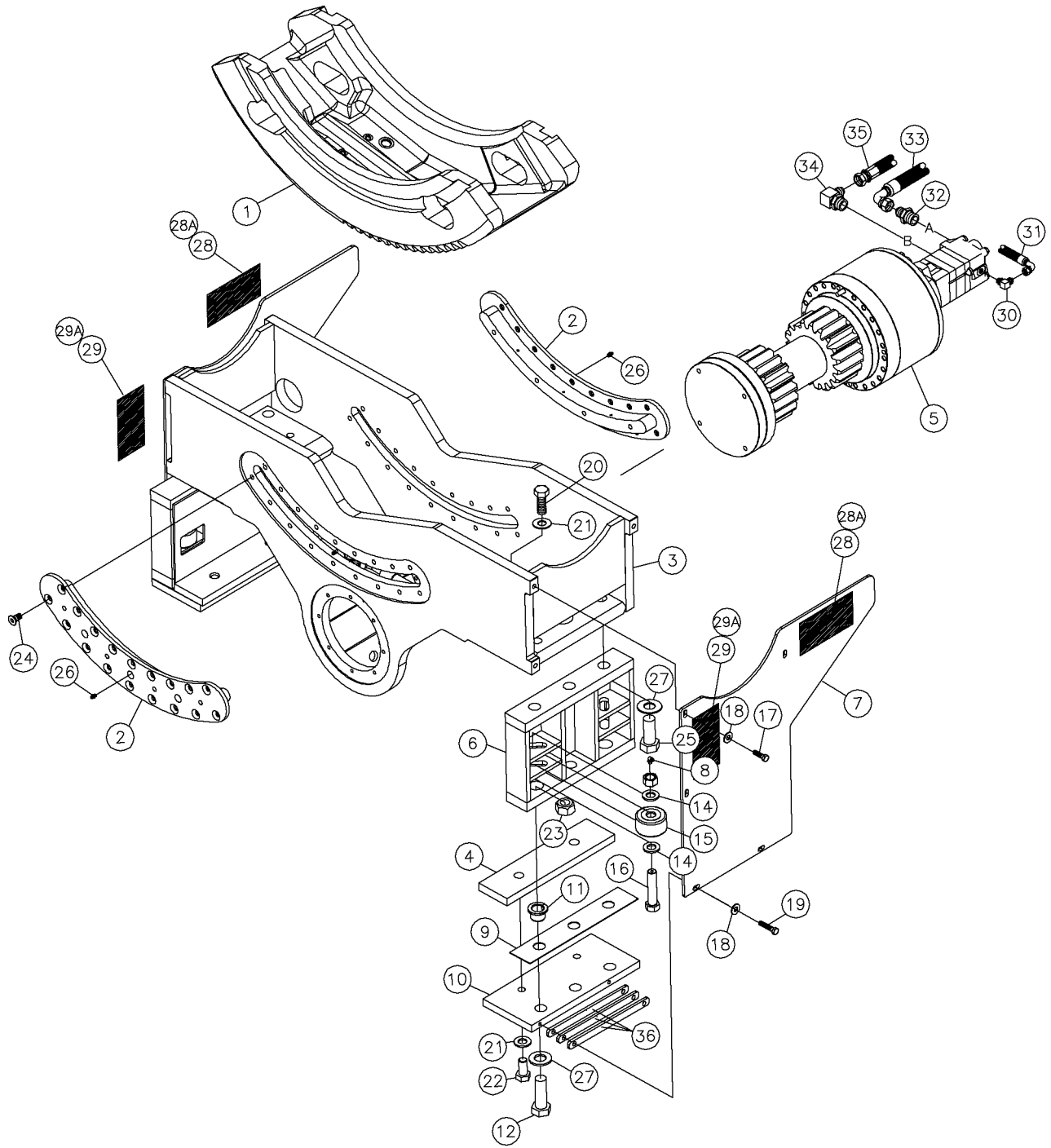

Vise Scissor Rotation Assy S/N 105 & 107-110 Fig 8-10

REF. NO.	*	PART NO.	DESCRIPTION	QTY.	REMARKS
		Revision Date	June, 2002		Addition To Manual
1		296262561	DRIVE GEAR	1	
2		296261651	WEAR RING-SCISSOR VISE	2	
3		296261613	REAR-VISE-MACHINE	1	
4		296261602	WEAR PAD - NYLON - 13.63"	2	
5		296261628	ASSY-GB DRIVE-SIZZOR VISE	1	Breakdown Fig. 8-12
6		296265373	VISE BRIDGE - MACHINE - REAR	2	
7		296265313	VISE-GUARD-REAR	2	
8		597001	ZERK-1/4" NF 90 DEG GREASE	4	
9		296265379	SHIM - VISE BRIDGE - REAR	2	
10		296265378	PLATE - VISE BRIDGE - REAR	2	
11		296265369	BUSHING - 1.015 X 1.312 X 1.06	2	
12		238887001	BOLT-1-8 X 3 HHCS GR8 ZY	6	
13		235739001	NUT-3/4-10 GR8 ZINC PLTD	4	
14		235717001	WASHER-3/4 FLAT HARDENED YELLOW ZINC	8	
15		288482001	ROLLER - 2 3/4 CAM	4	
16		296265371	BOLT - GREASE (.75-10 X 3.50)	4	
17		235736001	BOLT-3/8-16X1 1/4 ZINC PLTD	6	
18		510337607	WASHER-FLATSTD-.38-.44X1.00-.08-YZ	12	
19		235720001	BOLT-3/8-16X1 3/4 6R8 ZINC PLT	4	
20		235746001	BOLT-3/4-10X2 GR8 HEX ZNC PLTD	4	
21		295016001	WASHER, SAE FLAT 3/4	8	
22		238217001	BOLT-3/4-10X1 1/2 GR8 HEX ZYC	4	
23		75390001	NUT-1-UNC GR.8 TOP LOCK HEX	6	
24		231974010	SCREW-1/2-13 X 1 FLT HD SOCKET	36	
25		388024	BOLT-1-UNCX2 1/2 GR.8 HEX	4	
26		598001	ZERK-1/4" NF ST GREASE	6	
27		238892001	WASHER-1" HARDENED FLAT ZY	12	
28		7000B839	DECAL - WARNING	2	
28A		700IB839	DECAL - WARNING	2	International
29		7000A393	DECAL - DANGER	2	
29A		700IA393	DECAL - DANGER	2	International
30		60906001	4MX6M JIC 90 DEG ELBOW	1	
31		296054001	HOSE-HYD-.38 X 37 6FSJ 90/90 3000PSI	1	
32		53827001	FITT.-#10M O-RING-#10M JIC ST.	1	
33		296053001	HOSE-HYD-.63 X 36 10FSJ 90/90 3000PSI	1	
34		53829001	#10M O-RING-#10M JIC 90 DEG.	1	
35		257511001	HOSE-HYD-.63X37-10FSJ-ST/90-M3KMTF	1	
36		296265336	SHIM-GUARD	6	

Vise Scissor Rotation Bulkhead Assy S/N 111- Fig 8-11r01

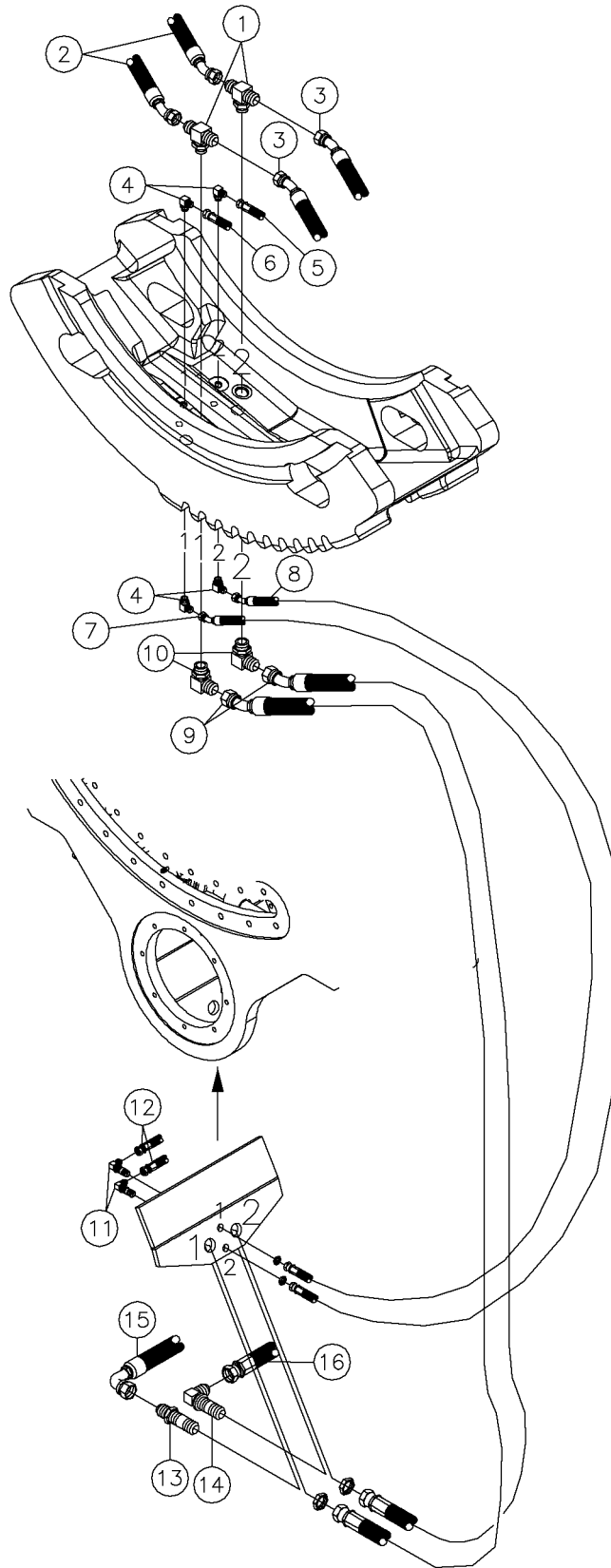

Vise Scissor Rotation Bulkhead Assy S/N 111- Fig 8-11r01

REF. NO.	*	PART NO.	DESCRIPTION	QTY.	REMARKS
		Revision Date	October, 2004		Update In Illustration & Parts List.
1		615104001	FITTING - BTEE-8MJ-8MJ-10MORB	2	
2		296061001	HOSE-HYD-.50 X 15.5 8FSJST45-3000PSIBNS	2	
3		296062001	HOSE-HYD.50X25-8FSJST/45-3000PSI BNS	2	
4		59423001	FIT-4M JICX4M ADJ.90 DEG.ELBOW	4	
5		296077001	HOSE-HYD-.25 X 22 3FSJ ST/ST 3000PSI	2	
6		53843183	HOSE-1/4X18 4FS JIC 3000 PSI	1	
7		296076001	HOSE-HYD-.25 X 33.5 4FSJ ST/45 3000PSI	1	
8		296259058	HOSE-HYD-.25X35.5 4FSJ ST/45 3000PSI	1	
9		296059001	HOSE-HYD -.63 X 32 10FSJ ST/45 3000PSI	2	
10		53829001	#10M O-RING-#10M JIC 90 DEG.	2	
11		61497001	FITTING-4M JIC BULKHEAD 90DEG.	2	
12		296075001	HOSE-HYD-.25 X 42 4FSJ ST/90 3000PSI	2	
13		77734001	FITTING-10M JIC BULKHEAD STR.	1	
14		77735001	FITTING - BH90 - 10MJ - 10MJ - LN	1	
15		296057001	HOSE-HYD-.63 X 45.5 10FSJ90/90-310ORIENT	1	
16		296058001	HOSE-HYD -.63 X 43 10FSJ ST/90 3000PSI	1	

Vise Scissor Rotation Bulkhead Assy S/N 105 & 107-110 Fig 8-11

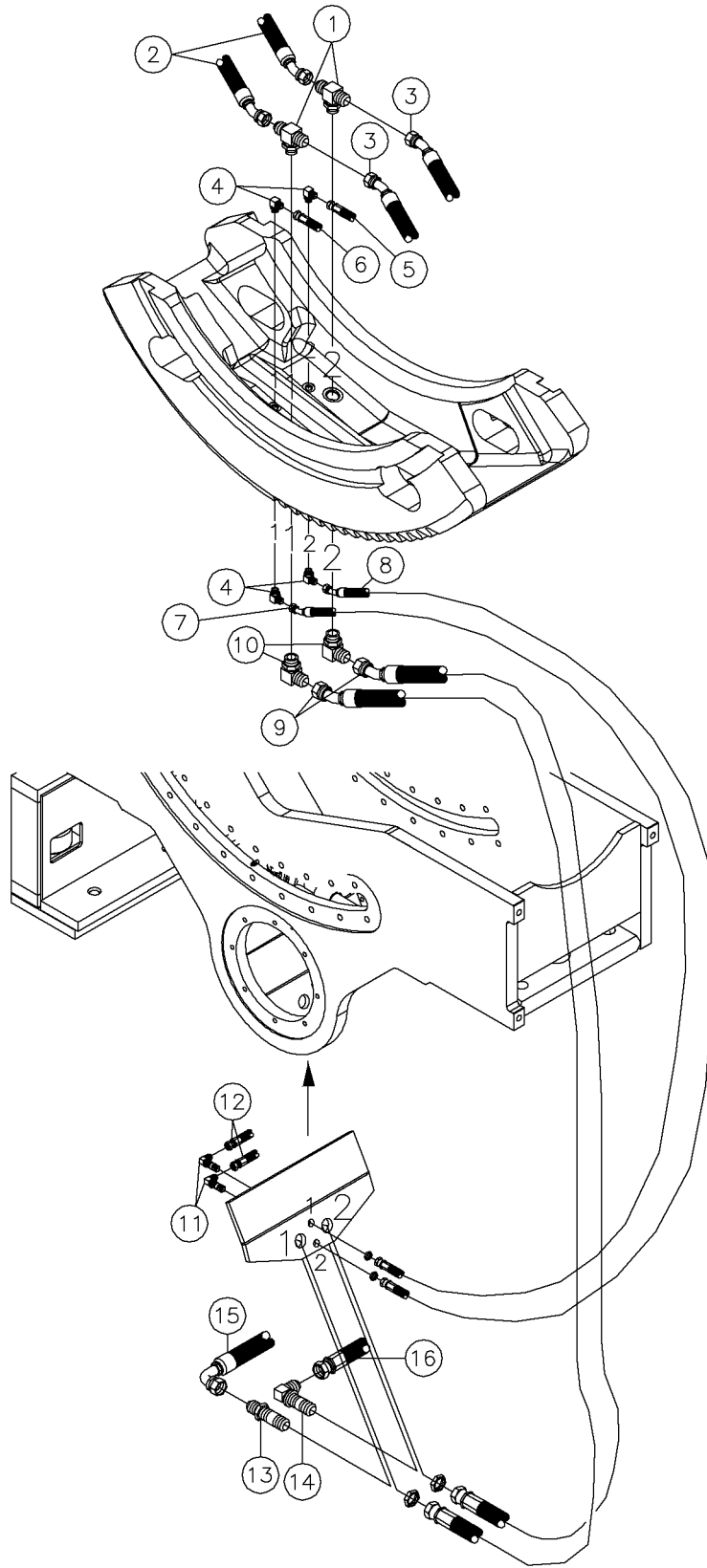

Vise Scissor Rotation Bulkhead Assy S/N 105 & 107-110 Fig 8-11

REF. NO.	*	PART NO.	DESCRIPTION	QTY.	REMARKS
		Revision Date	June, 2002		Addition To Manual
2		296061001	HOSE-HYD-.50 X 15.5 8FSJ ST/45 3000PSI	2	
3		296062001	HOSE-HYD-.50 X 25 8FSJ ST/45 3000PSI	2	
4		59423001	FIT-4M JICX4M ADJ.90 DEG.ELBOW	4	
5		296077001	HOSE-HYD-.25 X 22 3FSJ ST/ST 3000PSI	2	
6		53843183	HOSE-1/4X18 4FS JIC 3000 PSI	1	
7		296076001	HOSE-HYD-.25 X 33.5 4FSJ ST/45 3000PSI	1	
8		296259058	HOSE-HYD-.25 X 36.5 4FSJ ST/45 3000PSI	1	
9		296059001	HOSE-HYD -.63 X 32 10FSJ ST/45 3000PSI	2	
10		53829001	#10M O-RING-#10M JIC 90 DEG.	2	
11		61497001	FITTING-4M JIC BULKHEAD 90DEG.	2	
12		296075001	HOSE-HYD-.25 X 42 4FSJ ST/90 3000PSI	2	
13		77734001	FITTING-10M JIC BULKHEAD STR.	1	
14		77735001	FITTING - BH90 - 10MJ - 10MJ - LN	1	
15		296057001	HOSE-.63 X 45.5 10FSJ 90/90 3000PSI	1	
16		296058001	HOSE-.63 X 43 10FSJ ST/90 3000PSI	1	

Vise Scissor Drive Assy S/N 111- Fig 8-12r01

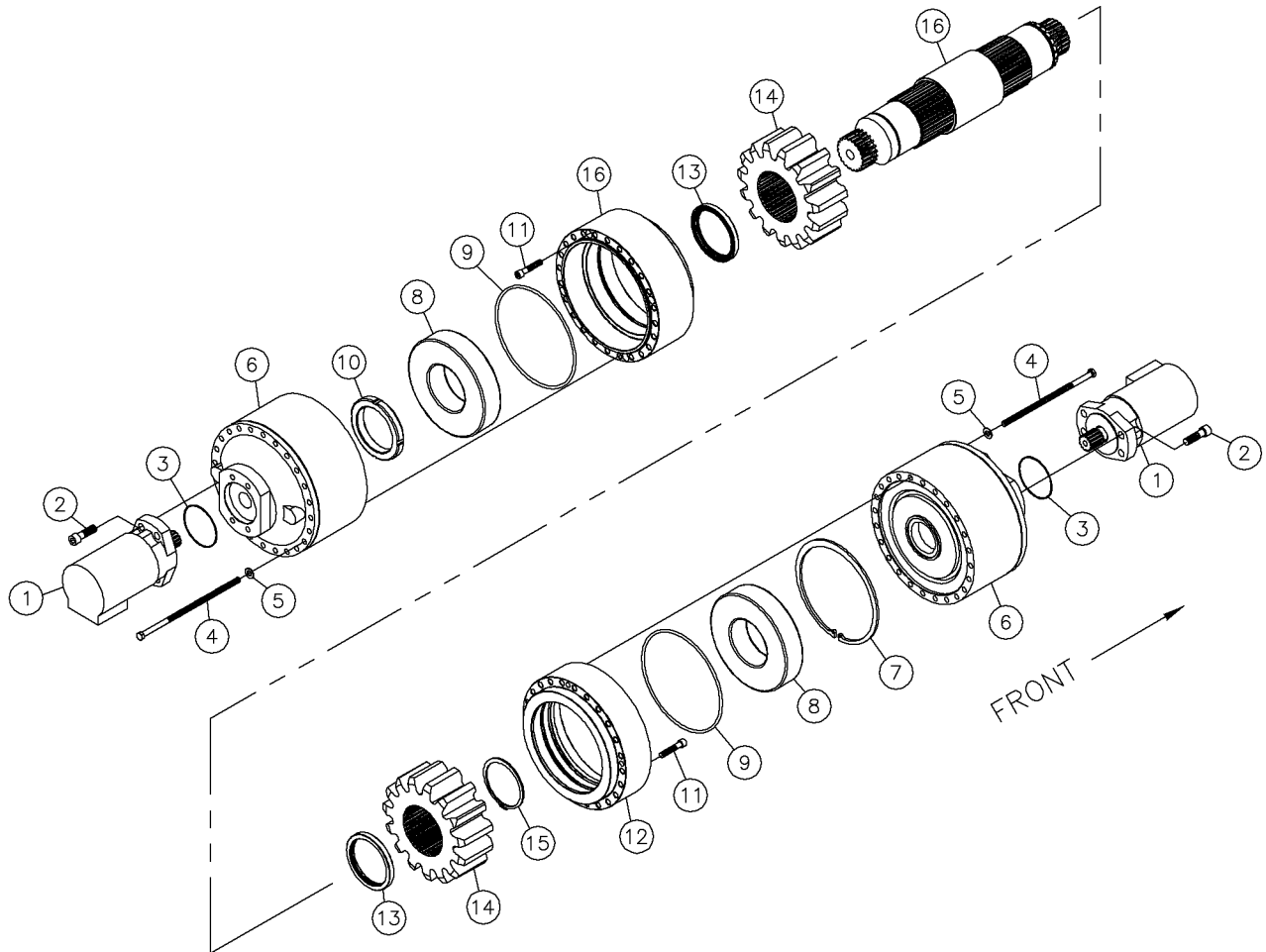

Vise Scissor Drive Assy S/N 111- Fig 8-12r01

REF. NO.	*	PART NO.	DESCRIPTION	QTY.	REMARKS
		Revision Date	October, 2004		Update In Illustration & Parts List.
1		296265252	HYD MOTOR - 2K-8CIR-4 BOLT MAG	2	Breakdown Fig. 12-48
2		229144001	CAPSCREW- 1/2-13 X 1 3/4SOC.HD	8	
3		4350001	O-RING 042 NAT. REF T09681	2	
4		510302080	SCREW-HCS-.38-16X8.00-GR5-YZ	48	
5		235713001	WASHER - FLATSTRL - .38 - .41 X .81 - .06-YA-A325	48	
6		296262570	GEARBOX - AUBURN HUB KIT MODEL 8	2	Breakdown Fig 12-47
7		296264095	SNAP RING (HO-800)	1	
8		296261630	BRG-75 X 160 X 37	2	
9		296264099	O-RING (AM200 X 5.0)	2	
10		296264093	JAM NUT (AN-19)	1	
11		243918001	CAPSCREW-3/8-16X2 SOC.HD ZP	8	
12		296264087	ADAPTER FLANGE	1	
13		296264094	SPACER/GEAR TWIN	2	
14		296264103	PINION - SCISSOR VISE - 2 D.P. (15 T)	2	
15		296264098	SNAP - RING (SH-375)	1	
16		296264088	ADAPTER FLANGE	1	
		296264084	ASSY - TWIN G.B. DRIVE		Included All Items In Figure

Vise Scissor Drive Assy S/N 105 & 107-110 Fig 8-12

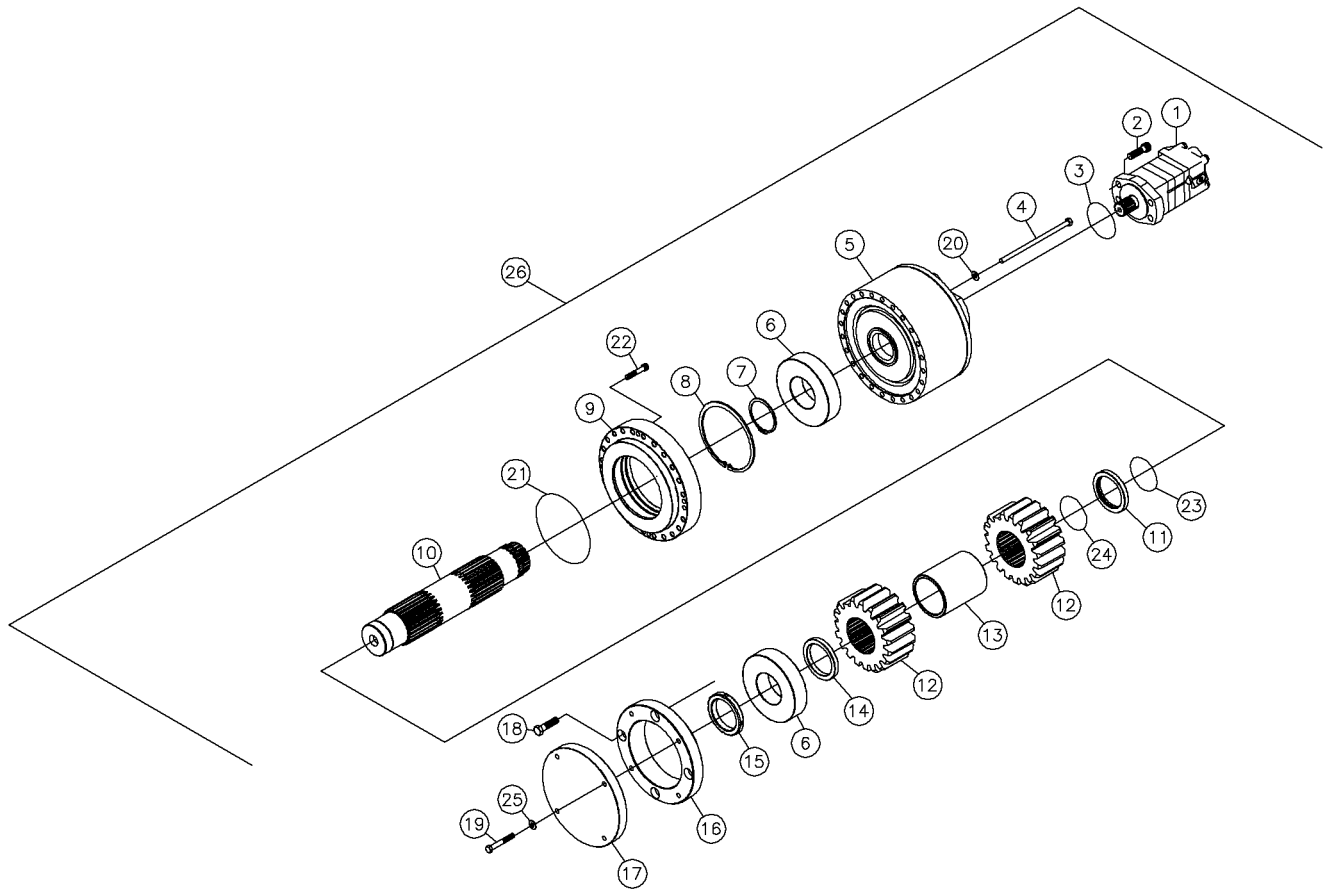

Vise Scissor Drive Assy S/N 105 & 107-110 Fig 8-12

REF. NO.	*	PART NO.	DESCRIPTION	QTY.	REMARKS
		Revision Date	June, 2002		Addition To Manual
1		296265252	HYD MOTOR - 2K-8CIR-4 BOLT MAG	1	Breakdown Fig. 12-48
2		229144001	CAPSCREW- 1/2-13 X 1 3/4SOC.HD	4	
3		4350001	O-RING 042 NAT.	1	
4		510302080	SCREW-HCS-.38-16X8.00-GR5-YZ	24	
5		296262570	GEARBOX - AUBURN HUB KIT MODEL 8	1	Breakdown Fig. 12-47
6		296261630	BRG-75 X 160 X 37	2	
7		296261636	SNAP RING N5100-293	1	
8		296261635	SNAP RING N500-625	1	
9		296261627	ADAPTER FLANGE-GB	1	
10		296265572	SHAFT - INPUT SPLINE	1	
11		296265347	SPACER-BRG/GEAR-INPUT	1	
12		296262571	PINION - SCISSOR VISE	2	
13		296261631	SLEEVE-GEAR	1	
14		296261632	SPACER-BRG/GEAR	1	
15		296261629	JAM NUT (AN-15)	1	
16		296261633	BRG HSG-GB DRIVE	1	
17		296261634	COVER-GB	1	
18		235723001	BOLT-3/8-16X1 1/2 GR8 ZINC PLT	4	
19		250640001	BOLT-3/8-16 X2 3/4 GR 8 Y/ZINC	4	
20		235713001	WASHER-3/8 SAE HARD ZINC PLTD	24	
21		296265349	O-RING	1	
22		243918001	CAPSCREW-3/8-16X2 SOC.HD ZP	4	
23		51165001	O-RING #152 (3 1/4X3 7/16X3/32)	1	
24		296265348	O-RING	1	
25		510337607	WASHER-FLATSTD-.38-.44X1.00-.08-YZ	4	
26		296261628	ASSY-GB DRIVE-SIZZOR VISE	1	Inc. All Items In Figure

Vise Center Support S/N 111- Fig 8-13r01

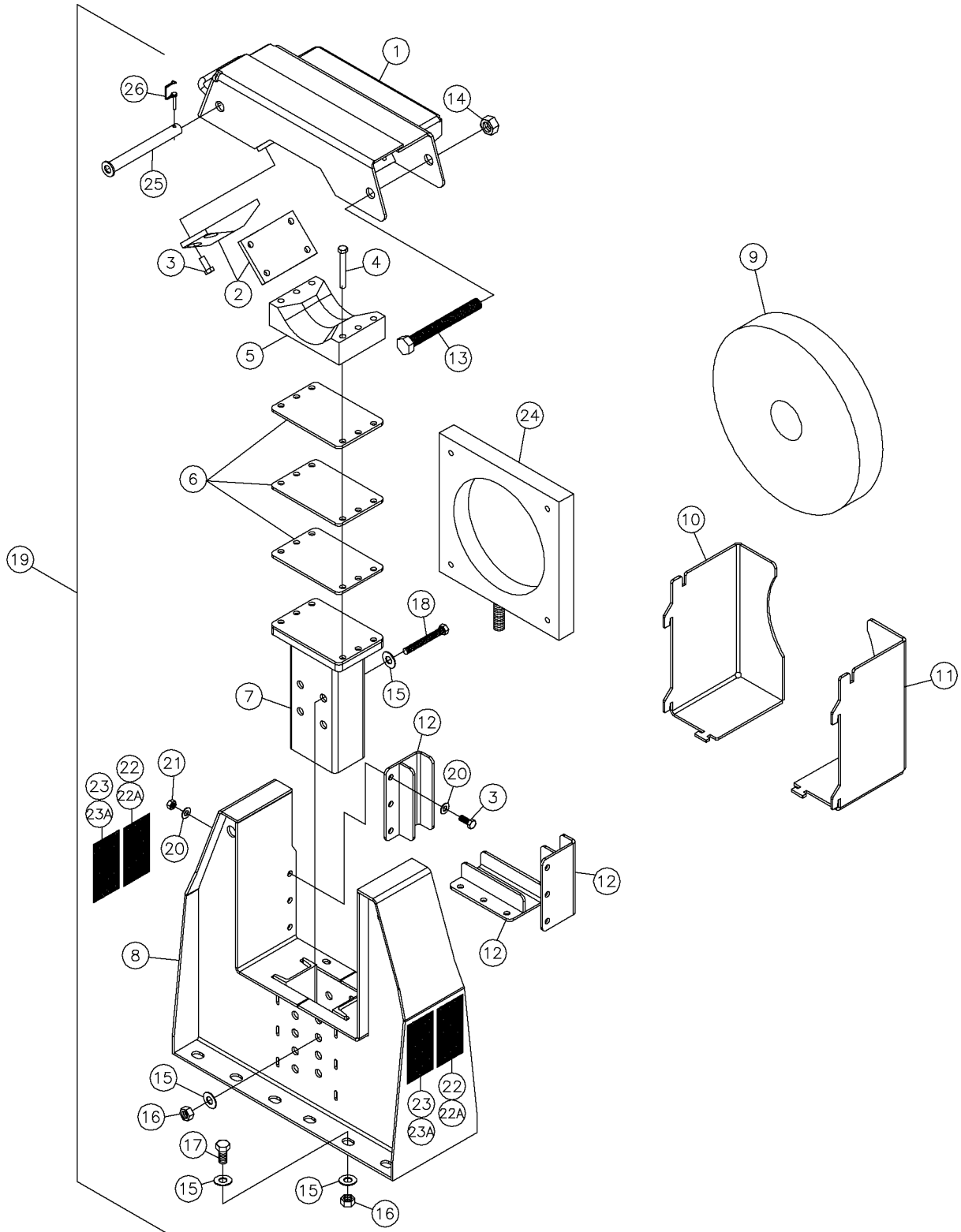

Vise Center Support S/N 111- Fig 8-13r01

REF. NO.	*	PART NO.	DESCRIPTION	QTY.	REMARKS
		Revision Date	October, 2004		Update In Illustration & Parts List.
1		296265267	WELDMENT-CENTER SUPPORT- DETACHABEL	1	
2		296265283	WEAR PLATE-CENTER SUPPORT- UPPER	2	
3		235737001	BOLT-1/2-13X1 1/4 GR8 ZINC PLT	16	
4		238244001	BOLT 1/2"-13 X 4"GR8 HEX Y/ZIN	6	
5		296265284	WEAR PLATE-CENTER SUPPORT-LWR	1	
6		296265325	SPACER-CENTER SUPPORT-.25	3	
7		296265270	WELDMENT-CENTER POST	1	
8		296265266	WELDMENT-CENTER SUPPORT-FIXED	1	
9		296265334	STRIPPING RUBBER - 4.5 X 19 X 3	1	
10		296265328	WELDMENT-WIPER SUPPORT-L.H.	1	
11		296265330	WELDMENT-WIPER SUPPORT-R.H.	1	
12		296265333	WELDMENT-MNT-STRIKE ALERT	3	
13		388090	BOLT-1 8UNCX9 GR.8	2	
14		75390001	NUT-1-UNC GR.8 TOP LOCK HEX	2	
15		235717001	WASHER-3/4 FLAT HARDENED YELLOW ZINC	28	
16		235739001	NUT-3/4-10 GR8 ZINC PLTD	14	
17		238217001	BOLT-3/4-10X1 1/2 GR8 HEX ZYC	12	
18		242884001	BOLT-3/4-10X5 1/2 GR8 ZINC	2	
19		296265265	ASSY-CENTER SUPPORT-DP	9	Inc. All Items In Figure
20		485025	WASHER-1/2 FLAT-HARDENED-ZINC	16	
21		235731001	NUT-1/2-13 GR8 ZINC PLTD	9	
22		7000A393	DECAL - DANGER	2	
22A		700IA393	DECAL - DANGER	2	International
23		7000A394	DECAL - WARNING	2	
23A		700IA394	DECAL - WARNING	2	International
24		244590001	ZAP ALERT-COIL	1	
25		296265430	ASSY-HINGE PIN-1.0 X 9	1	
26		2108001	LYNCH PIN - 1/4 X 2 REF T11609	1	

Vise Center Support S/N 105 & 107-110 Fig 8-13

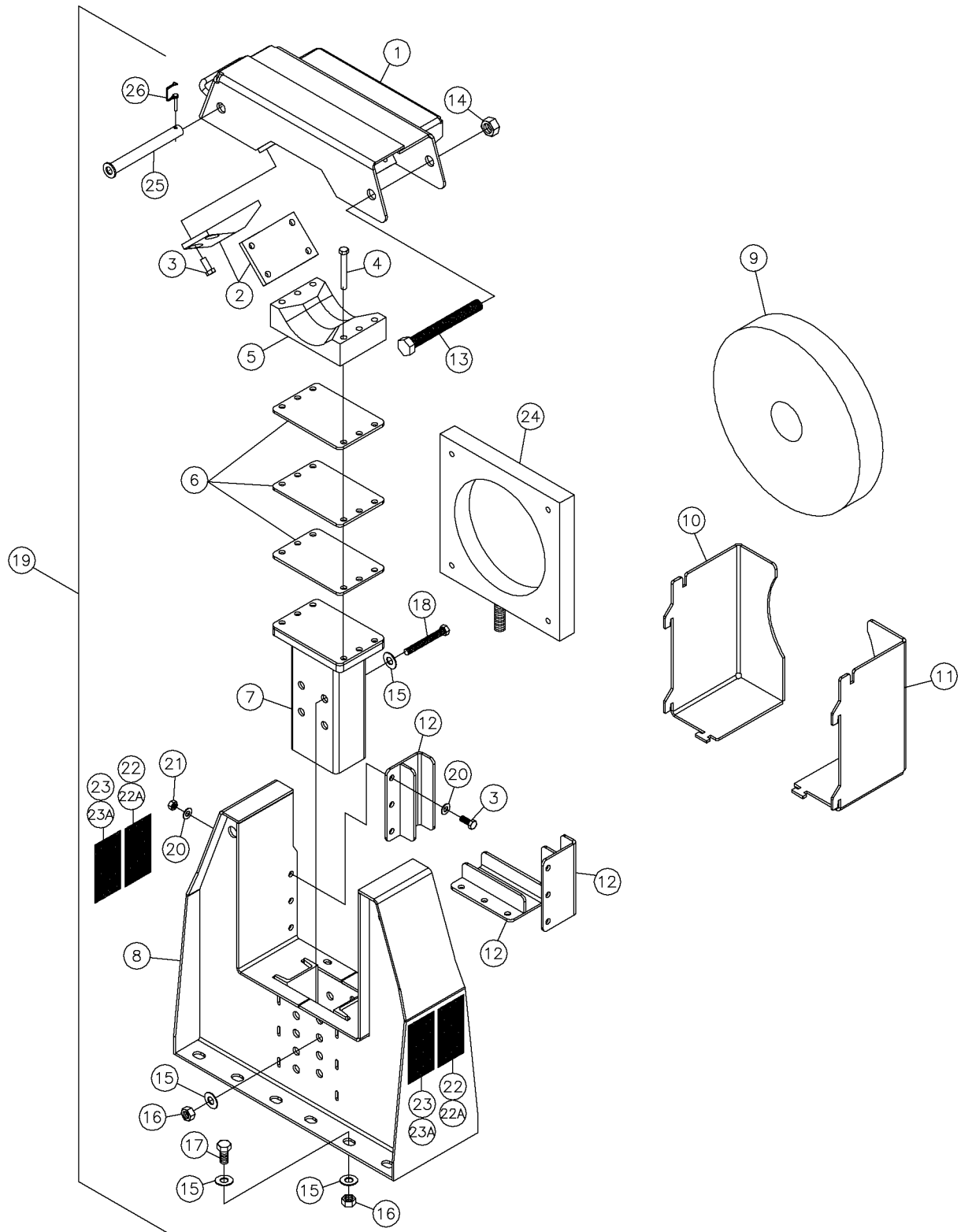

Vise Center Support S/N 105 & 107-110 Fig 8-13

REF. NO.	*	PART NO.	DESCRIPTION	QTY.	REMARKS
		Revision Date	June, 2002		Addition To Manual
1		296265267	WELDMENT-CENTER SUPPORT- DETACHABEL	1	
2		296265283	WEAR PLATE-CENTER SUPPORT- UPPER	2	
3		235737001	BOLT-1/2-13X1 1/4 GR8 ZINC PLT	16	
4		238244001	BOLT 1/2"-13 X 4"GR8 HEX Y/ZIN	6	
5		296265284	WEAR PLATE-CENTER SUPPORT-LWR	1	
6		296265325	SPACER-CENTER SUPPORT-.25	3	
7		296265270	WELDMENT-CENTER POST	1	
8		296265266	WELDMENT-CENTER SUPPORT-FIXED	1	
9		296265334	STRIPPING RUBBER - 4.5 X 19 X 3	1	
10		296265328	WELDMENT-WIPER SUPPORT-L.H.	1	
11		296265330	WELDMENT-WIPER SUPPORT-R.H.	1	
12		296265333	WELDMENT-MNT-STRIKE ALERT	3	
13		388090	BOLT-1 8UNCX9 GR.8	2	
14		75390001	NUT-1-UNC GR.8 TOP LOCK HEX	2	
15		235717001	WASHER-3/4 FLAT HARDENED YELLOW ZINC	28	
16		235739001	NUT-3/4-10 GR8 ZINC PLTD	14	
17		238217001	BOLT-3/4-10X1 1/2 GR8 HEX ZYC	12	
18		242884001	BOLT-3/4-10X5 1/2 GR8 ZINC	2	
19		296265265	ASSY-CENTER SUPPORT-DP	9	Inc. All Items In Figure
20		485025	WASHER-1/2 FLAT-HARDENED-ZINC	16	
21		235731001	NUT-1/2-13 GR8 ZINC PLTD	9	
22		7000A393	DECAL - DANGER	2	
22A		700IA393	DECAL - DANGER	2	International
23		7000A394	DECAL - WARNING	2	
23A		700IA394	DECAL - WARNING	2	International
24		244590001	ZAP ALERT-COIL	1	
25		296265430	ASSY-HINGE PIN-1.0 X 9	1	
26		2108001	LYNCH PIN - 1/4 X 2 REF T11609	1	

Vise Scissor Vise Manifold Assy S/N 111- Fig 8-14r01

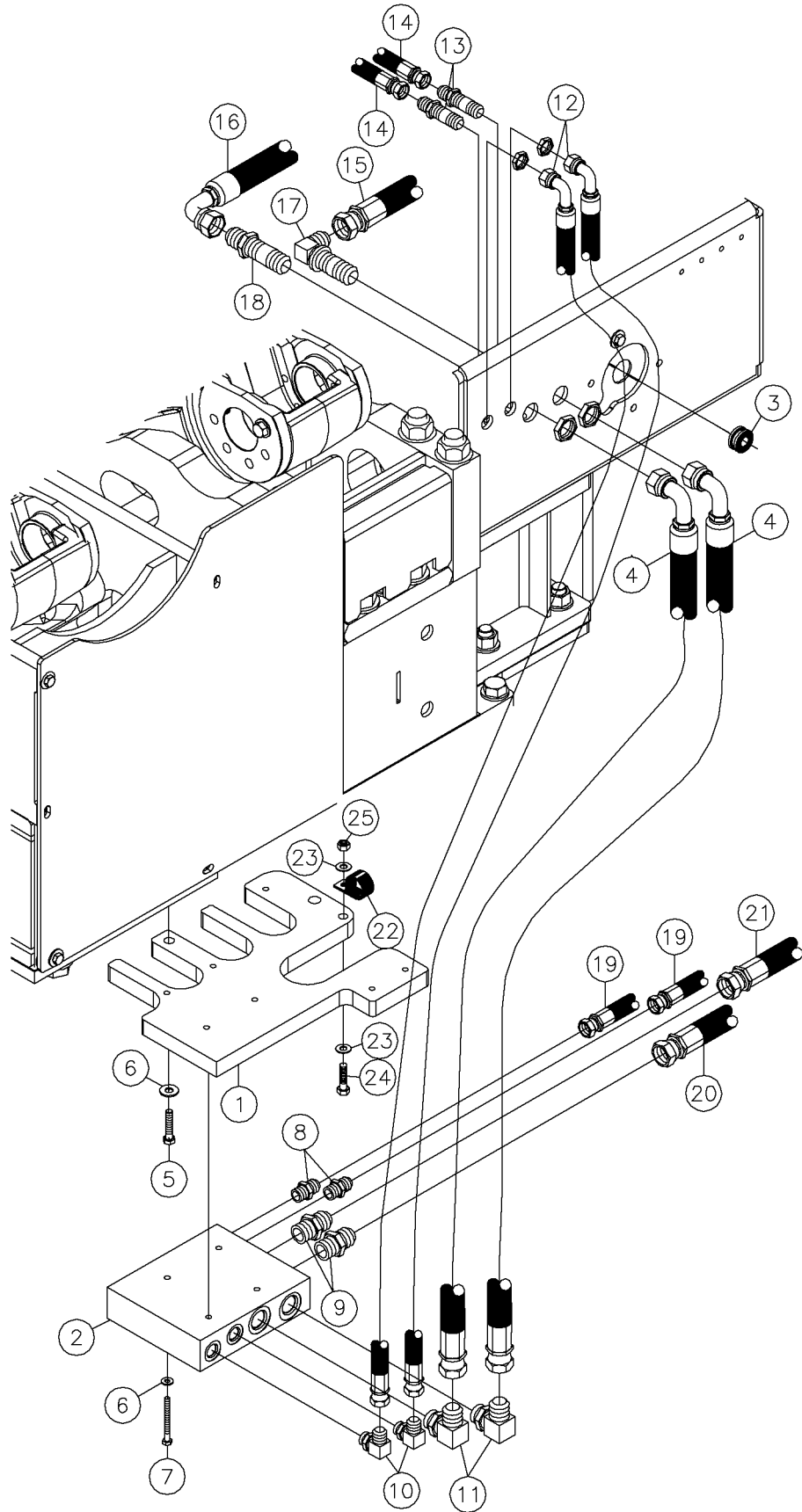

Vise Scissor Vise Manifold Assy S/N 111- Fig 8-14r01

REF. NO.	*	PART NO.	DESCRIPTION	QTY.	REMARKS
		Revision Date	October, 2004		Update In Illustration & Parts List.
1		296264147	ADAPTER PLATE - MANIFOLD -D300	1	
2		296264177	MANIFOLD - SCISSORS VISE - D300	1	
3		283182001	RUBBER GROMMET - FRONT RACK HARNESS	1	
4		276782001	HOSE-3/4X23 12FSJIC ST/90 M3K	2	
5		235720001	BOLT-3/8-16X1 3/4 6R8 ZINC PLT	3	
6		510337607	WASHER-FLATSTD-.38-.44X1.00-.08-YZ	7	
7		250640001	BOLT-3/8-16 X2 3/4 GR 8 Y/ZINC	4	
8		53824001	FITTING-#8M O-RING-#8M JIC ST.	2	
9		53828001	#12M O-RING-#12M JIC ST.	2	
10		53837001	FITTING - 8M O-RING X 8M JIC 90 DEGREE	2	
11		59410001	FITTING-90-12MJ-12MORBA	2	
12		257225001	HOSE-1/2X24 8FS/8FS90L 3000PSI	2	
13		60927001	8 JIC BULKHEAD ST.UNION	2	
14		296069001	HOSE-HYD-.50 X 18.0 8FSJ ST/45 3000PSI	2	
15		296052001	HOSE-HYD-.75X18.5 12FSJ ST/ST 3000PSI	1	
16		296051001	HOSE-HYD-.75X 21 12FSJ ST/90 3000PSI	1	
17		108500001	FITTING-12MJICX90 BULKHEAD	1	
18		201485001	12M JIC X 12M JIC BULKHEAD STR	1	
19		296056001	HOSE-HYD-.50 X 366 8FSJ ST/903KPSI BNS	2	
20		296050001	HOSE-HYD-.75X278 12FSJ ST/12 3000PSI M3K	1	
21		296070001	HOSE-HYD-.75 X 366 12FSJ-ST/12FSJ-ST M3K	1	
22		70076001	CLIP-CUSHION KMC CDV-0813	1	
23		235713001	WASHER - FLATSTRL - .38 - .41 X .81 - .06-YA-A325	2	
24		235723001	SCREW - HCS -.38 - 16 X 1.50 - GR8 - YZ	1	
25		235725001	NUT - HEX - .38 - 16 - GR8 - YZ	1	

Vise Scissor Vise Manifold Assy S/N 105 & 107-110 Fig 8-14

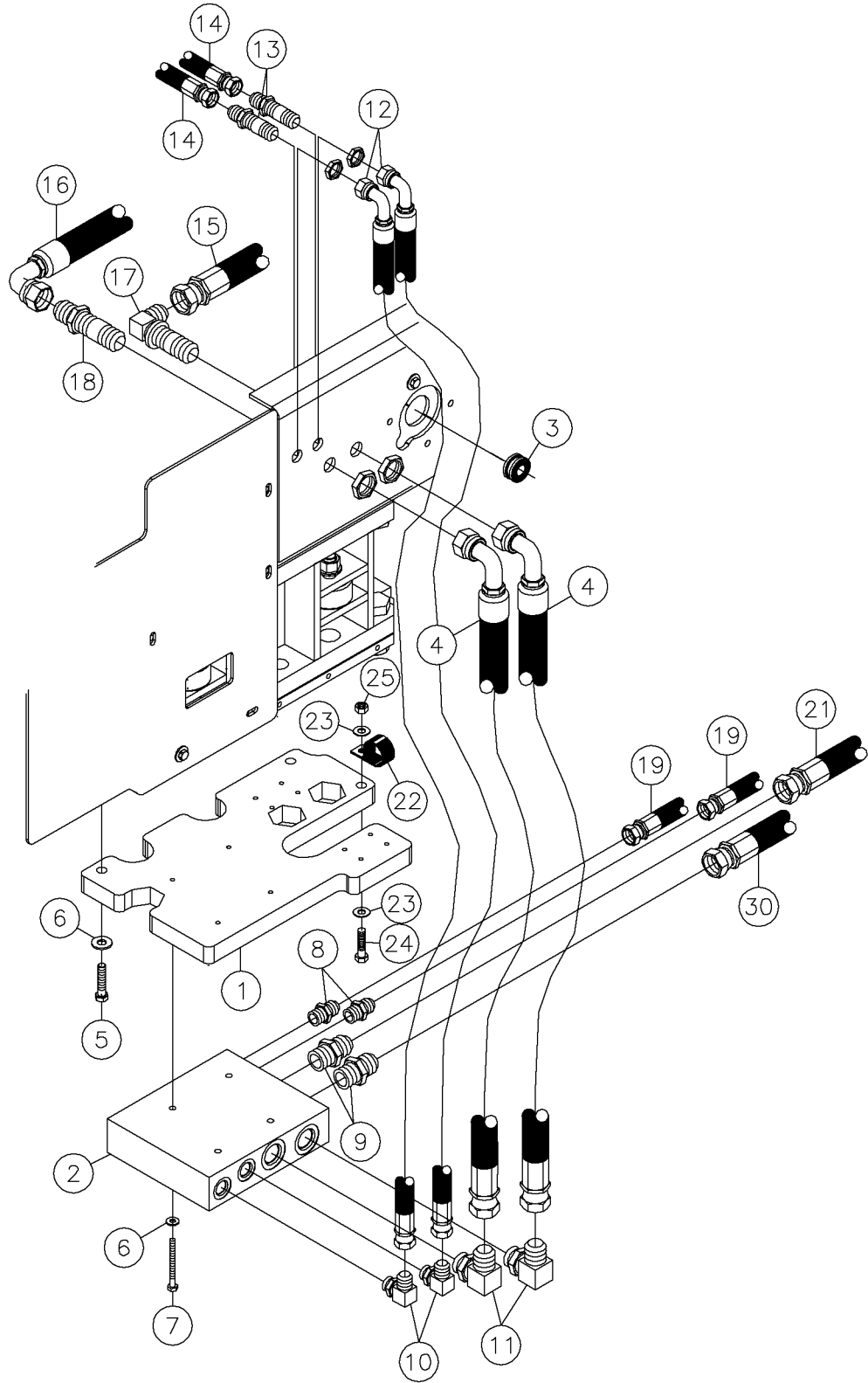

Vise Scissor Vise Manifold Assy S/N 105 & 107-110 Fig 8-14

REF. NO.	*	PART NO.	DESCRIPTION	QTY.	REMARKS
		Revision Date	June, 2002		Addition To Manual
1		296265365	PLATE - ADAPTER - MANIFOLD	1	
2		296265364	MANIFOLD - SCISSORS VISE	1	
3		283182001	RUBBER GROMMET - FRONT RACK HARNESS	1	
4		276782001	HOSE-3/4X23 12FSJIC ST/90 M3K	2	
5		235720001	BOLT-3/8-16X1 3/4 6R8 ZINC PLT	3	
6		510337607	WASHER-FLATSTD-.38-.44X1.00-.08-YZ	7	
7		354026	BOLT-3/8-16X2 3/4" GRADE#5HEX	4	
8		53824001	FITTING-#8M O-RING-#8M JIC ST.	2	
9		53828001	#12M O-RING-#12M JIC ST.	2	
10		53837001	FITTING - 8M O-RING X 8M JIC 90 DEGREE	2	
11		59410001	FITTING-12M JICX12M ADJ. 90 DEG.ELBOW	2	
12		257225001	HOSE-1/2X24 8FS/8FS90L 3000PSI	2	
13		60927001	8 JIC BULKHEAD ST.UNION	2	
14		296069001	HOSE-HYD-.50 X 18.0 8FSJ ST/45 3000PSI	2	
15		296052001	HOSE-HYD-.75X18.5 12FSJ ST/ST 3000PSI	1	
16		296051001	HOSE-HYD-.75X 21 12FSJ ST/90 3000PSI	1	
17		108500001	FITTING-12MJICX90 BULKHEAD	1	
18		201485001	12M JIC X 12M JIC BULKHEAD STR	1	
19		296056001	HOSE-HYD-.50 X 366 8FSJ ST90 3000PSI	2	
20		296050001	HOSE-HYD-.75X278 10FSJ ST/ST 3000PSI	1	
21		296070001	HOSE-HYD-.75 X 366 10FSJ ST/ST 3000PSI	1	
22		70076001	CLIP-CUSHION KMC CDV-0813	1	
23		235713001	WASHER - FLATSTRL - .38 - .41 X .81 - .06-YA-A325	2	
24		235723001	SCREW - HCS - .38 - 16 X 1.50 - GR8 - YZ	1	
25		235725001	NUT - HEX - .38 - 16 - GR8 - YZ	1	

Cable Crane-Hyd Flow Diagram Fig 9-1

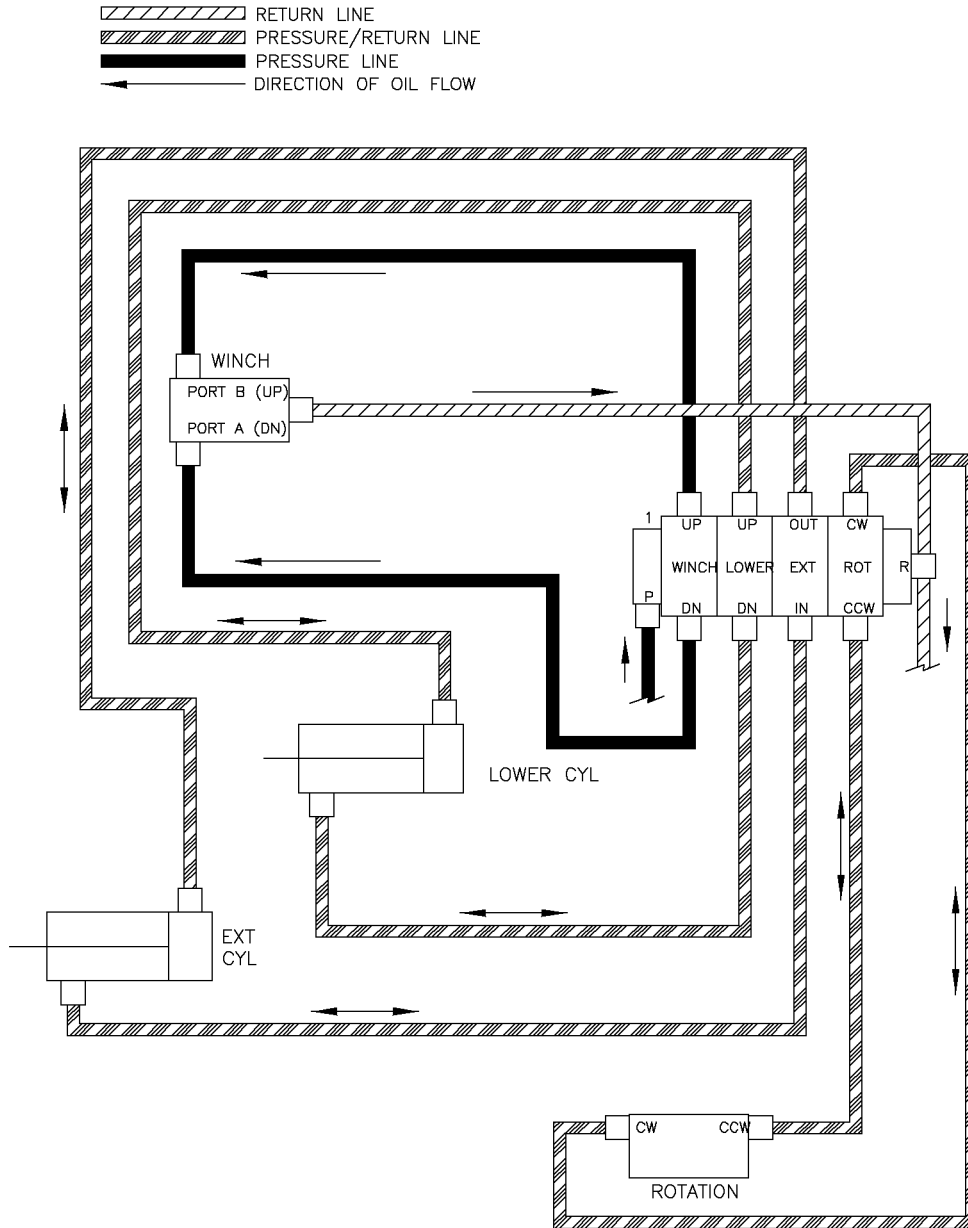

Cable Crane-Hyd Flow Diagram Fig 9-1

REF. NO.	*	PART NO.	DESCRIPTION	QTY.	REMARKS

Cable Crane-Frame Assy Fig 9-2r01

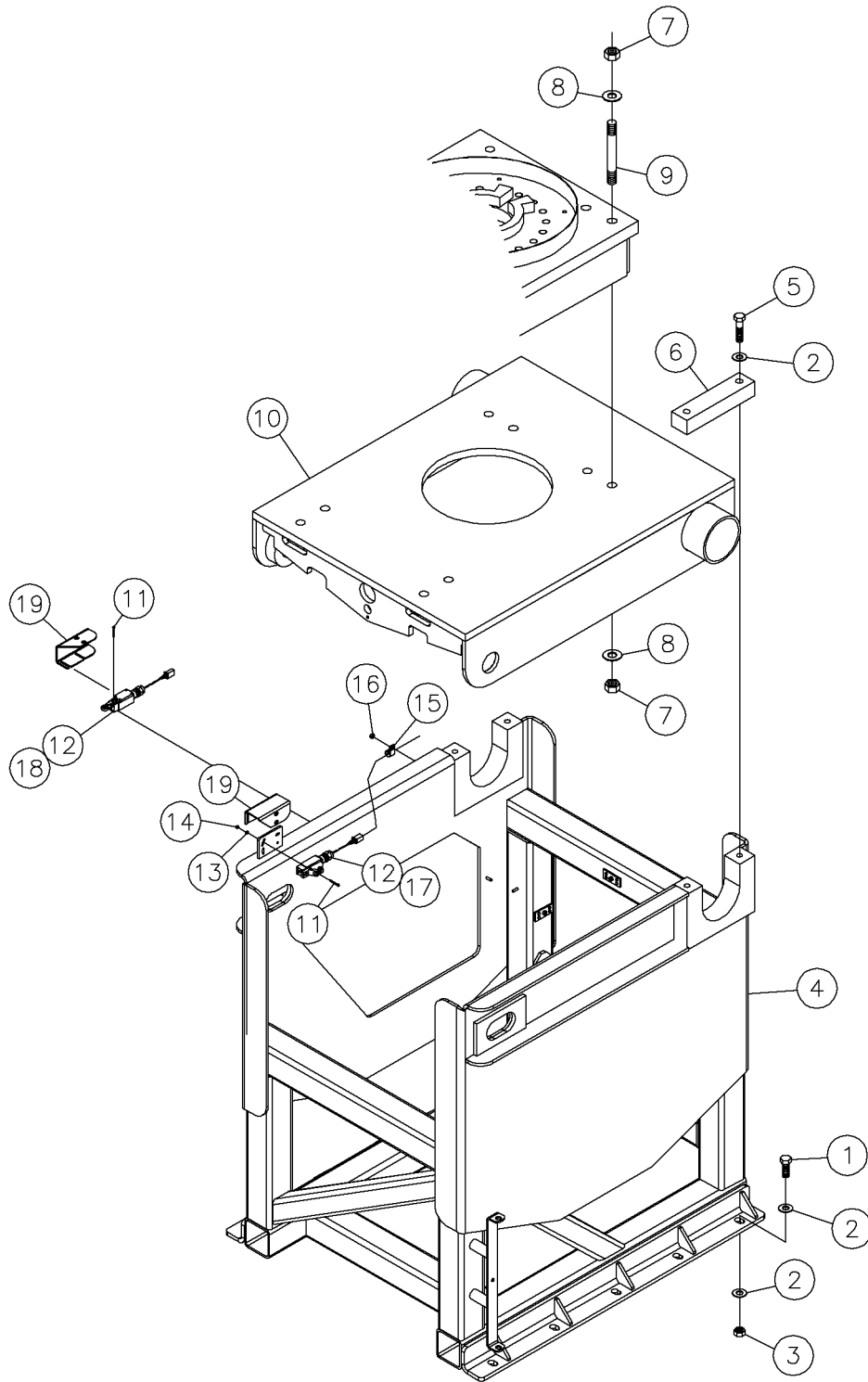

Cable Crane-Frame Assy Fig 9-2r01

REF. NO.	*	PART NO.	DESCRIPTION	QTY.	REMARKS
		Revision Date	October, 2004		Update In Illustration & Parts List.
1		235746001	BOLT-3/4-10X2 GR8 HEX ZNC PLTD	8	
2		235717001	WASHER-3/4 FLAT HARDENED YELLOW ZINC	17	
3		235739001	NUT-3/4-10 GR8 ZINC PLTD	8	
4		296267800	CRANE FRAME	1	
5		238242001	BOLT 3/4"-10 X 3" GR8 HEX Y/Z	4	
6		292791001	MOUNT - CRANE TUBE	2	
7		296261961	STUD	16	
8		485019	WASHER-1" FLAT REF TR00360	16	
9		296261962	NUT	8	
10		292798001	CRANE - BASE WELDMENT	1	
11		533003	SCREW - MCH - 10-24 X 1.50 - GR2-CZ-ROUND-SLTD	8	
12		285690001	SWITCH - LIMIT NO/NC SIDE ROTARY/PIGTAIL	2	
13		485001	WASHER - FLATSTD - .19 - .22 X .56 - .05 - CZ	2	
14		400001	NUT-3/16 NC HEX REF T09423	2	
15		2595001	HOSE CLAMP - TS7FR 1/2" REF T15802	2	
16		235741001	NUT - HEX - .31 - 18 - GR8 -YZ	2	
17		285693001	LEVER - LIMIT SWITCH OFFSET	1	
18		285691001	LEVER - LIMIT SWITCH STRAIGHT	1	
19		296258436	SHIELD - SWITCH	2	

Cable Crane-Frame Assy Fig 9-2

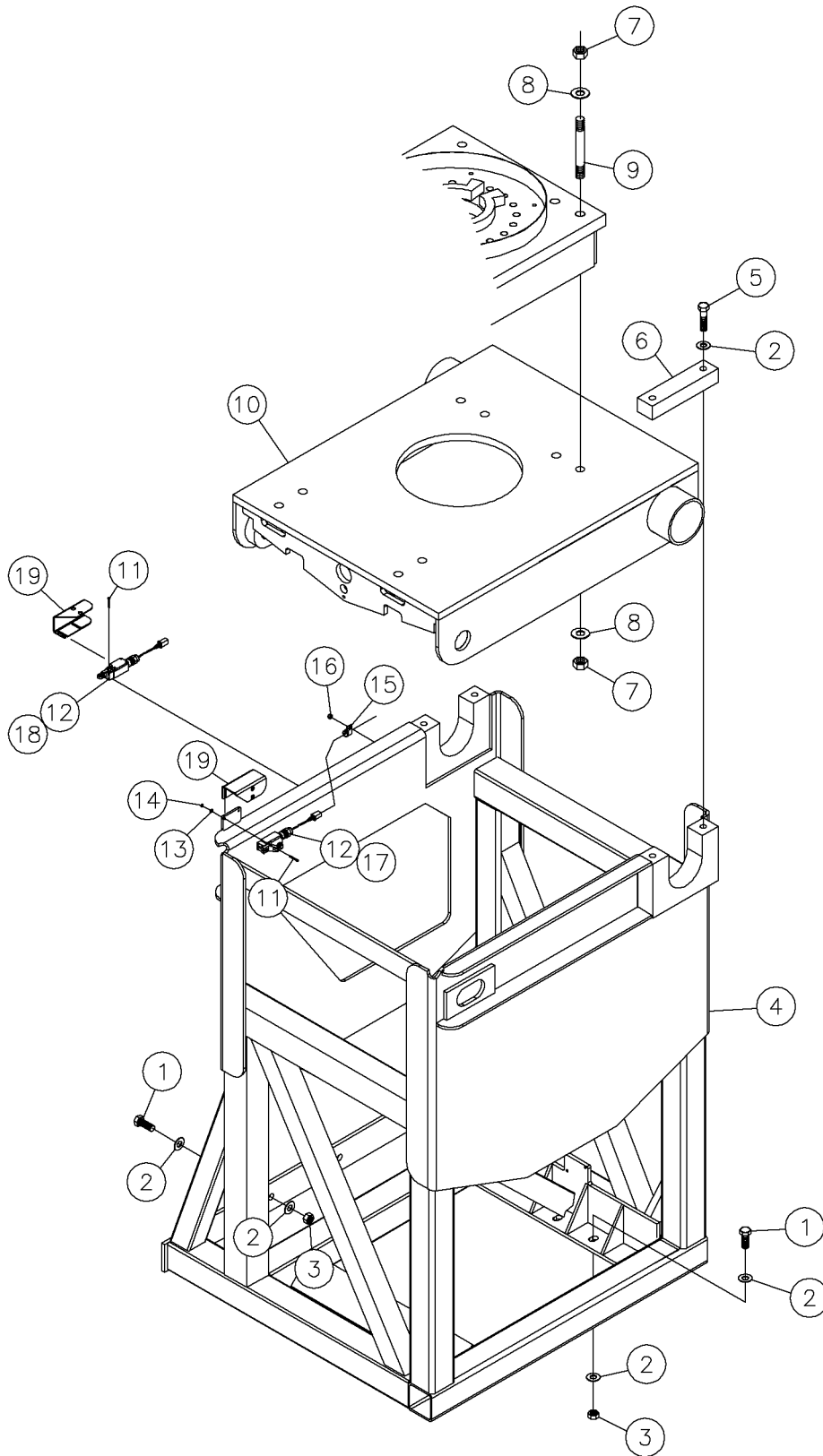

Cable Crane-Frame Assy Fig 9-2

REF. NO.	*	PART NO.	DESCRIPTION	QTY.	REMARKS
1		235746001	BOLT-3/4-10X2 GR8 HEX ZNC PLTD	10	
2		235717001	WASHER-3/4 FLAT HARDENED YELLOW ZINC	24	
3		235739001	NUT-3/4-10 GR8 ZINC PLTD	10	
4		292800001	CRANE FRAME	1	
5		238242001	BOLT 3/4"-10 X 3" GR8 HEX Y/Z	4	
6		292791001	MOUNT - CRANE TUBE	2	
7		296261961	STUD	16	
8		485019	WASHER-1" FLAT	16	
9		296261962	NUT	8	
10		292798001	CRANE - BASE WELDMENT	1	
11		533003	SCREW 10-24X1-1/2 RND HD SLT	8	
12		285690001	SWITCH - LIMIT NO/NC SIDE ROTARY/ PIGTAIL	2	
13		485001	WASHER-3/16 FLAT	2	
14		400001	NUT-3/16 NC HEX	2	
15		2595001	HOSE CLAMP - TS7FR 1/2"	2	
16		235741001	NUT-5/16-18 GR8 ZINC PLTD	2	
17		285693001	LEVER - LIMIT SWITCH OFFSET	1	
18		285691001	LEVER - LIMIT SWITCH STRAIGHT	1	
19		296258436	SHIELD - SWITCH	2	

Cable Crane-Base Lock Cylinder Assy Fig 9-3r01

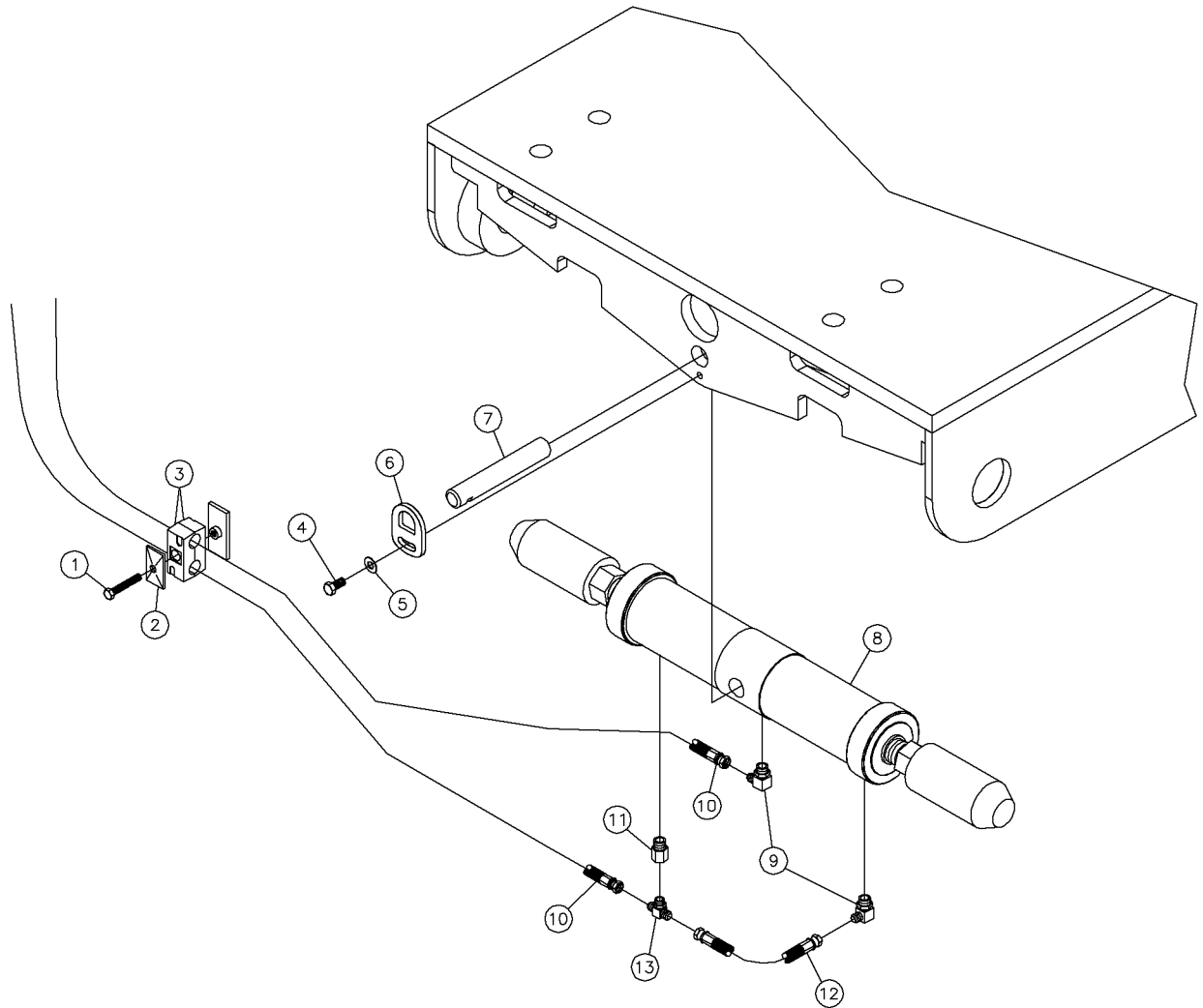

Cable Crane-Base Lock Cylinder Assy Fig 9-3r01

REF. NO.	*	PART NO.	DESCRIPTION	QTY.	REMARKS
		Revision Date	October, 2004		Update In Illustration & Parts List.
1		351012	BOLT-5/16"-18X1 1/4"GR5 HEX REF T03059	2	
2		67846003	PLATE-TWIN COVER	2	
3		67846005	CLAMP-PAIR-1/2" PIPE/1/4" HYD. HOSE	2	
4		235726001	BOLT-3/8-16X3/4 GR8 HEX ZNCPLT	1	
5		235713001	WASHER - FLATSTRL - .38 - .41 X .81 - .06-YA-A325	1	
6		277961001	PLATE - PIN RETAINER	1	
7		277960001	PIN - 1" X 5.25"	1	
8		292850001	CYLINDER - 3" X 3" - DOUBLE ROD	1	Breakdown Fig 12-14
9		57950001	FITTING-90-4MJ-6MORBA	2	
10		53843207	HOSE-1/4X76 4FS JIC 3000 PSI	2	
11		67291001	FITTING - STR - 6MORB - 4FORB	1	
12		296256888	HOSE - .25 X 13 4 FS JIC ST/ST M3K	1	
13		81343001	4M (BCH)X4M JICX4M JIC TEE	1	

Cable Crane-Base Lock Cylinder Assy Fig 9-3

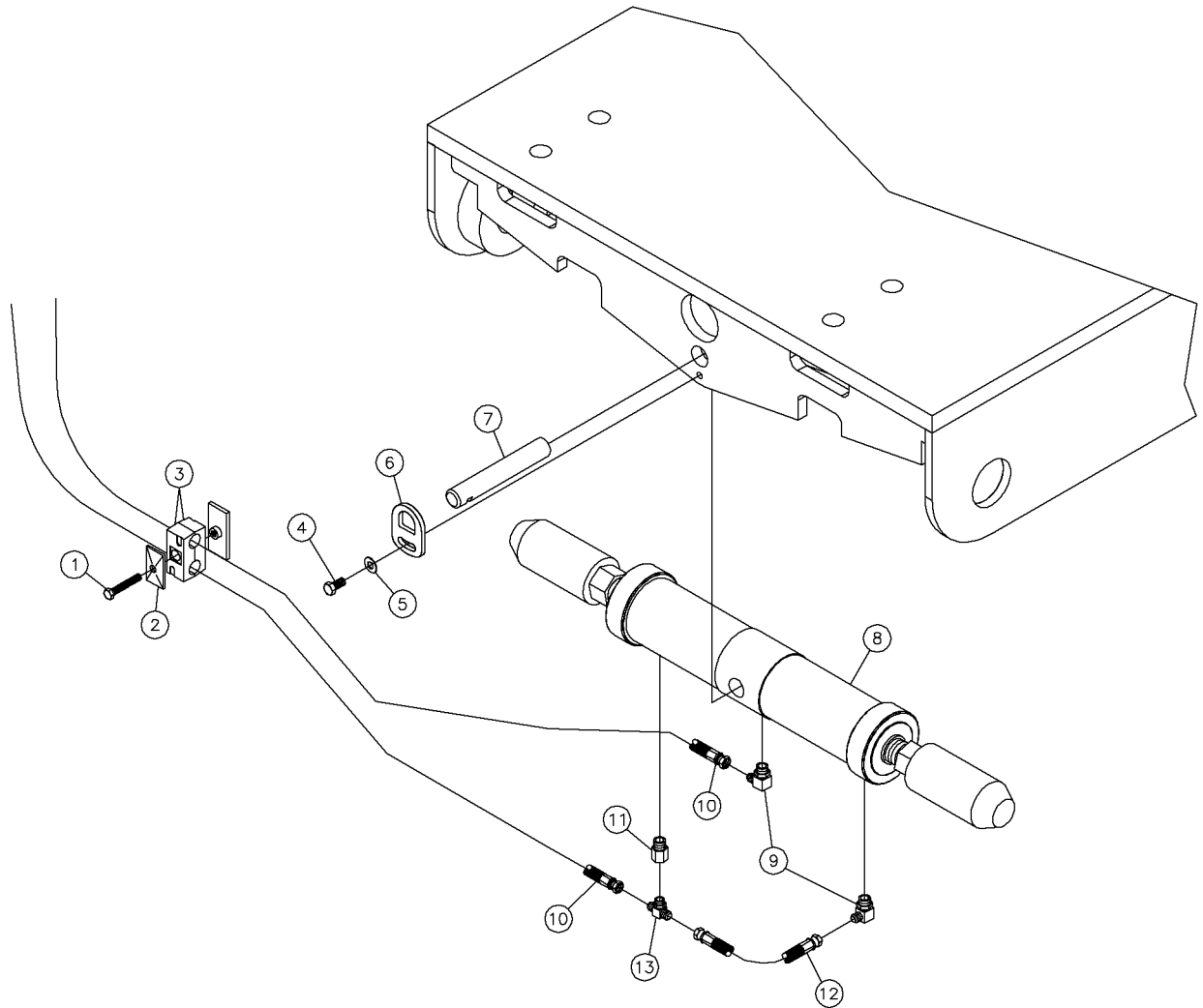

Cable Crane-Base Lock Cylinder Assy Fig 9-3

REF. NO.	*	PART NO.	DESCRIPTION	QTY.	REMARKS
1		351012	BOLT-5/16"-18X1 1/4"GR5 HEX	2	
2		67846003	PLATE-TWIN COVER	2	
3		67846005	CLAMP-TWIN (PAIR) 3/8 HYD. HOSE	2	
4		235726001	BOLT-3/8-16X3/4 GR8 HEX ZNCPLT	1	
5		235713001	WASHER-3/8 SAE HARD ZINC PLTD	1	
6		277961001	PLATE - PIN RETAINER	1	
7		277960001	PIN - 1" X 5.25"	1	
8		292850001	CYLINDER - 3" X 3" - DOUBLE ROD	1	Breakdown Fig 12-14
9		57950001	FITTING-90-4MJ-6MORBA	2	
10		53843489	HOSE-1/4X100 4FS JIC 3000 PSI	2	
11		67291001	FITTING-6MX4F SOLID REDUCER	1	
12		296256888	HOSE - .25 X 13 4 FS JIC ST/ST M3K	1	
13		81343001	FITTING-4M (BCH)X4M JICX4M JIC TEE	1	

Cable Crane-Contoller Assy (Deleted) Fig 9-4r01

FIGURE DELETED DUE TO UPDATE

Cable Crane-Contoller Assy (Deleted) Fig 9-4r01

REF. NO.	*	PART NO.	DESCRIPTION	QTY.	REMARKS
		Revision Date	October, 2004		Deleted From Manual

Cable Crane-Contoller Assy Fig 9-4

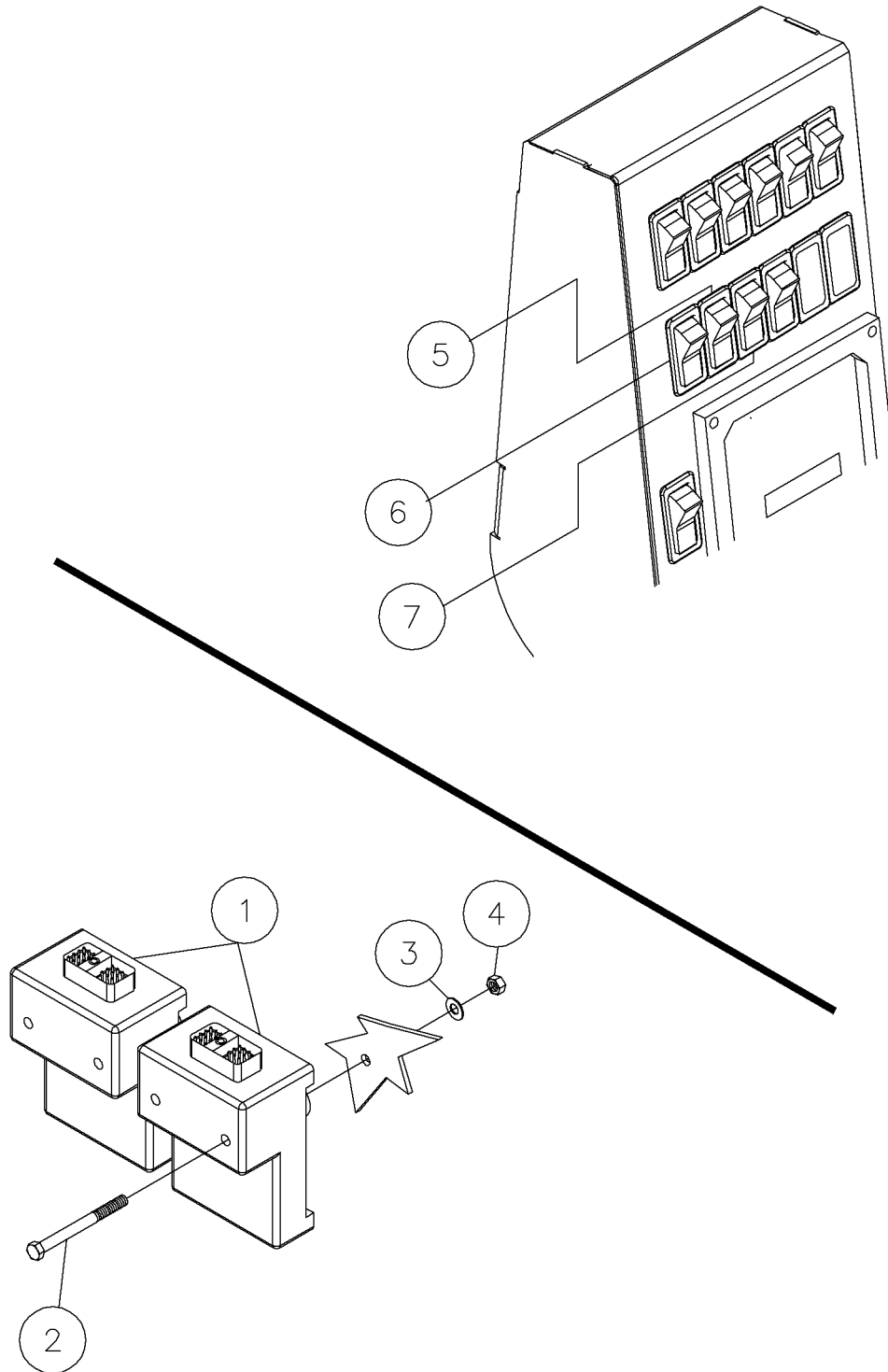

Cable Crane-Contoller Assy Fig 9-4

REF. NO.	*	PART NO.	DESCRIPTION	QTY.	REMARKS
1		283020001	CRANE CONTROLLER	2	
2		250644001	BOLT-1/4-20 X2 1/4 GR 8 Y/ZINC	4	
3		235716001	WASHER-1/4 SAE HARD ZINC PLTD	4	
4		235732001	NUT-1/4-20 GR8 ZINC PLTD	4	
5		283085001	ROCKER SWITCH-CRANK BASE LOCK	1	
6		283101001	ROCKER SWITCH-WINCH SPEED	1	
7		283086001	ROCKER SWITCH-CRANE BASE LIFT	1	

Cable Crane-Base Assy Fig 9-5

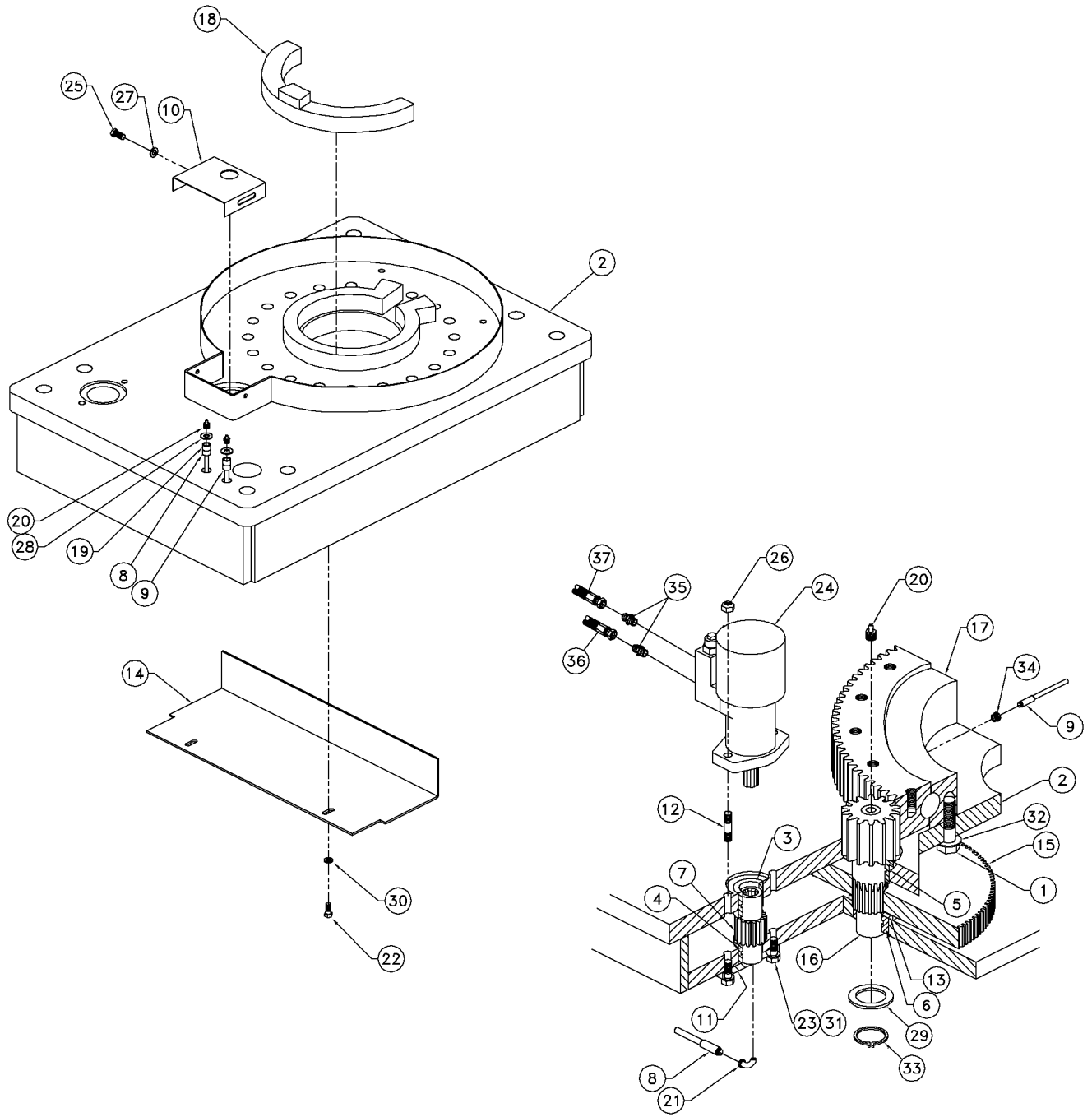

Cable Crane-Base Assy Fig 9-5

REF. NO.	*	PART NO.	DESCRIPTION	QTY.	REMARKS
1		124620034	BOLT-3/4-10X3 1/2 GR8 HEX ZINC	20	
2		296261800	BASE - WELDMENT 7025	1	Inc Ref No's 3-7
3		296261799	BUSHING - B148 ROTATION	1	PAIR OF 2
4		296261798	BUSHING - B148 ROTATION SM CRANE	1	PAIR OF 2
5		296261797	BUSHING - BASE	1	PAIR OF 2
6		296261796	BUSHING - BASE	1	PAIR OF 2
7		296261795	GEAR - DRIVE	1	PAIR OF 2
8		296261794	HOSE	1	
9		296261793	HOSE	1	
10		296261792	COVER - PINION GEAR	1	
11		296261791	GREASE PLATE - DRIVE GEAR	1	
12		296261790	STUD - BRAKE/MOTOR	2	
13		296261789	SPACER - PINION GEAR	1	
14		296261788	GUARD - GEAR INTERMEDIATE 7025	1	
15		296261787	GEAR - INTMD	1	
16		296261786	GEAR PINION	1	
17		296261785	GEAR - TRNTBL - BRG	1	
18		296261784	CASTING - SLIDE	1	
19		296261783	COUPLING - BLK	2	
20		586001	ZERK-1/8" ST NPT GREASE	3	
21		4017001	FITTING-3400X2 WTHR-HD	1	
22		235742001	BOLT-5/16-18X3/4 GR8 ZINC PLTD	2	
23		358012	BOLT-1/2-13 X 1 1/4 GR #5 HEX	2	
24		296261779	MOTOR ASM W/CB	1	
25		353006	BOLT-5/16-18X3/4 TPBPT FLG	2	
26		504680001	LOCKNUT-1/2 NC NYLON INSERT PLT	2	
27		235714001	WASHER-5/16 SAE HARD ZINC PLTD	2	
28		235713001	WASHER-3/8 SAE HARD ZINC PLTD	2	
29		296261782	MACH BUSHING	1	
30		480005	WASHER-5/16 S/T LOCK	2	
31		480011	WASHER-1/2 S/T LOCK	2	
32		235717001	WASHER-3/4 FLAT HARDENED YELLOW ZINC	20	
33		296261781	RETAINING RING	1	
34		296261780	REDUCER BUSH - STL	1	
35		60908001	FITTING-4MX4M JIC STR ADAPTER	2	
36		296261886	HOSE - 1/4"	1	
37		296261882	HOSE - 1/4"	1	

Cable Crane-Mast Assy Fig 9-6

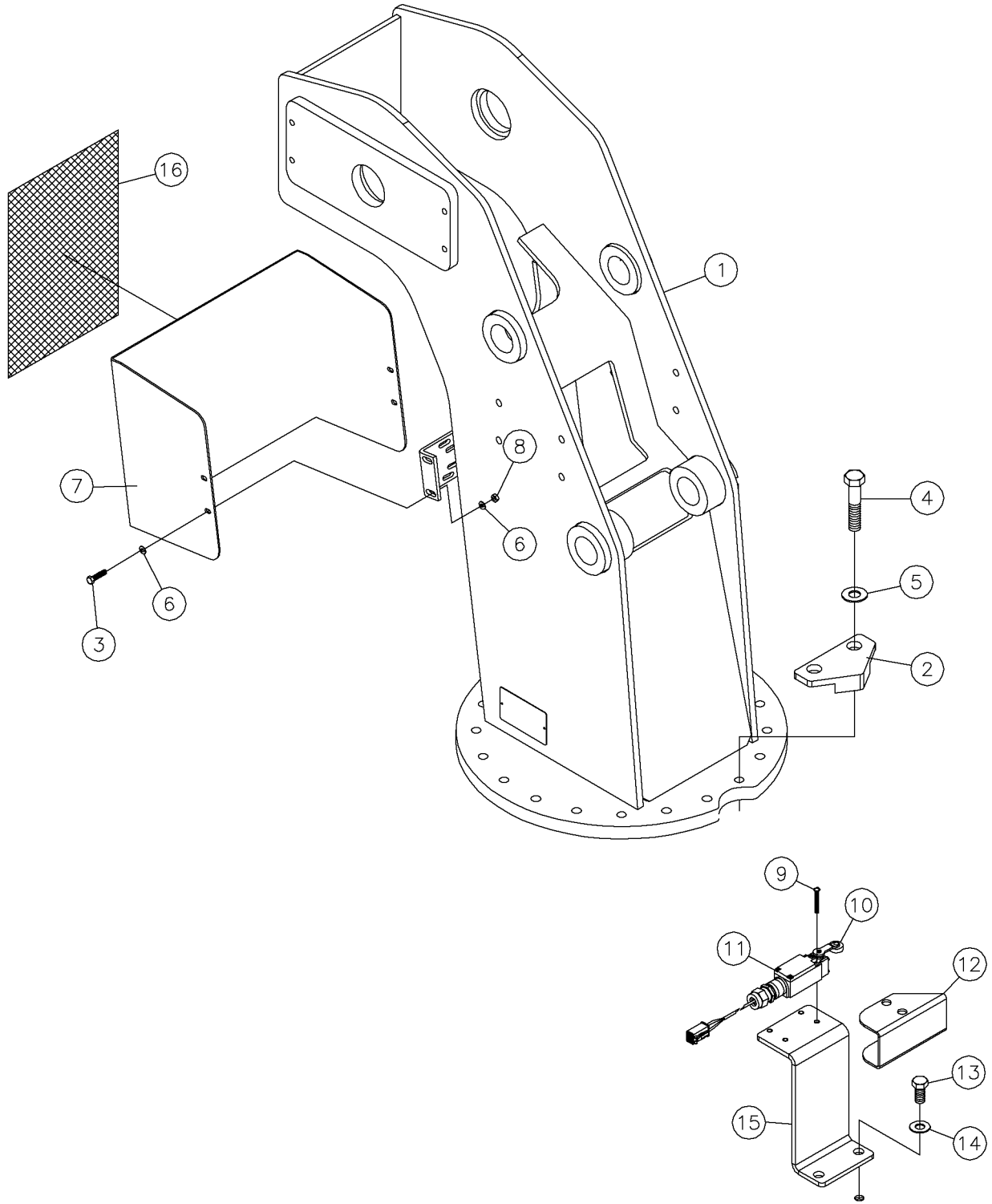

Cable Crane-Mast Assy Fig 9-6

REF. NO.	*	PART NO.	DESCRIPTION	QTY.	REMARKS
1		296261767	MAST - WELDMENT	1	
2		292763001	MOUNT CRANE	1	
3		350010	BOLT-1/4-20 X 1" GRADE #5 HEX	4	
4		235747001	BOLT-5/8-11X3 GR8 HEX ZNC PLTD	20	
5		235715001	WASHER-5/8 SAE HARD ZINC PLTD	20	
6		235716001	WASHER-1/4 SAE HARD ZINC PLTD	8	
7		296261769	COVER	1	
8		103201001	NUT-1/4-20NC NYLON INSERT LOCK	4	
9		533003	SCREW 10-24X1-1/2 RND HD SLT	4	
10		285691001	LEVER - LIMIT SWITCH STRAIGHT	1	
11		285690001	SWITCH - LIMIT NO/NC SIDE ROTARY/ PIGTAIL	1	
12		296258436	SHIELD - SWITCH	1	
13		235729001	SCREW-HCS-.50-13X1.00-GR8-YZ	2	
14		485025	WASHER-1/2 FLAT-HARDENED-ZINC	2	
15		296261555	BRACKET - ALPHA ZONE SWITCH	1	
16		296264802	DECAL-CAPACITY CHART 8.25 X 12	1	

Cable Crane-Extension Boom Assy Fig 9-7

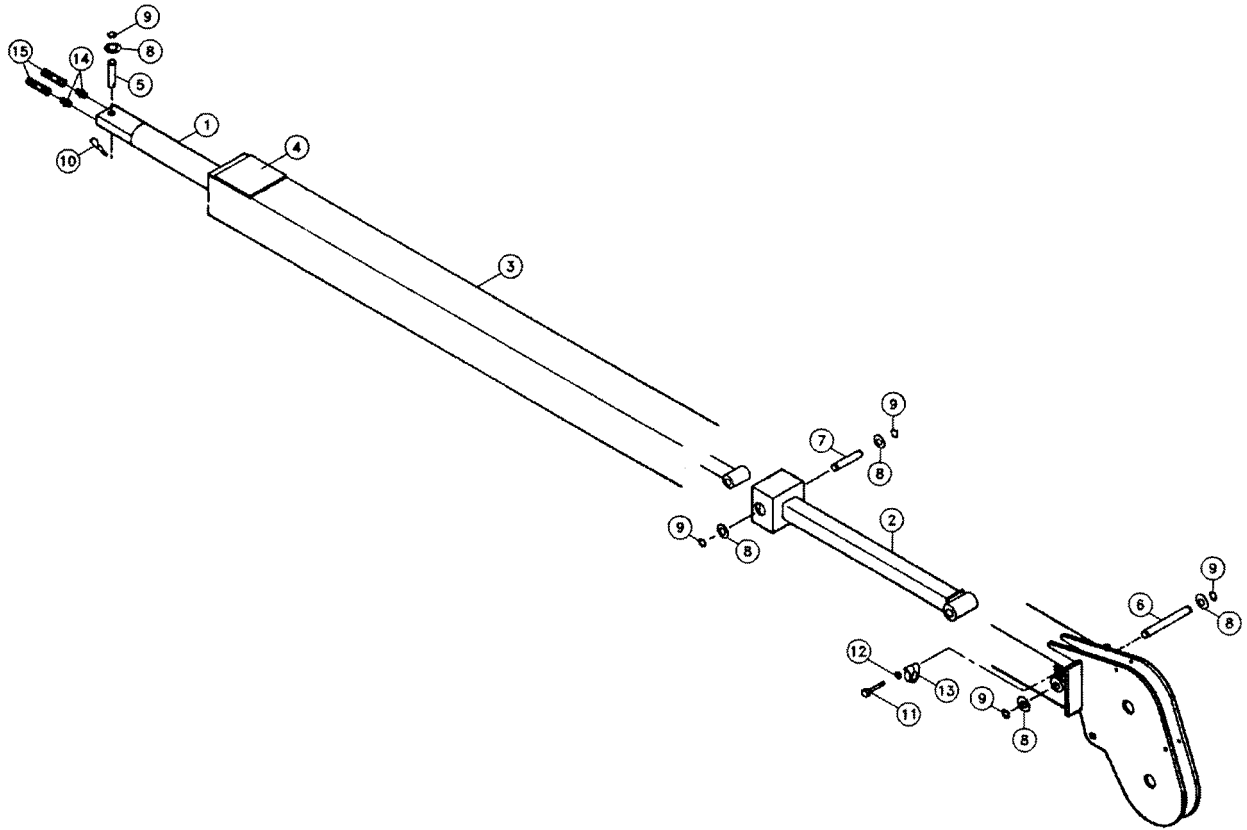

Cable Crane-Extension Boom Assy Fig 9-7

REF. NO.	*	PART NO.	DESCRIPTION	QTY.	REMARKS
2		296261777	LINK	1	
3		296261761	EXTENSION BOOM	1	
4		296261762	WEAR PAD	1	
5		296261763	PIN	1	
6		296261764	PIN	1	
7		296261778	PIN	1	
8		296261765	MACH BUSHING 1 X 10 GA	4	
9		296261766	RETAINING RING 1" EXT	3	
10		20667001	HAIR PIN COTTER - .177 WIRE	1	
11		350014	BOLT-1/4-20X1 1/2"GRADE#5 HEX	1	
12		480003	WASHER-1/4 S/T LOCK	1	
13		296256743	SUPPORT - GP STAUFF LN-4190-PA	1	
13		296261760	EXTENSION CYLINDER	1	Breakdown Fig 12-20
14		53824001	FITTING-#8M O-RING-#8M JIC ST.	2	
15		296261883	HOSE 1/2"	2	

Cable Crane-Lower Boom Assy Fig 9-8

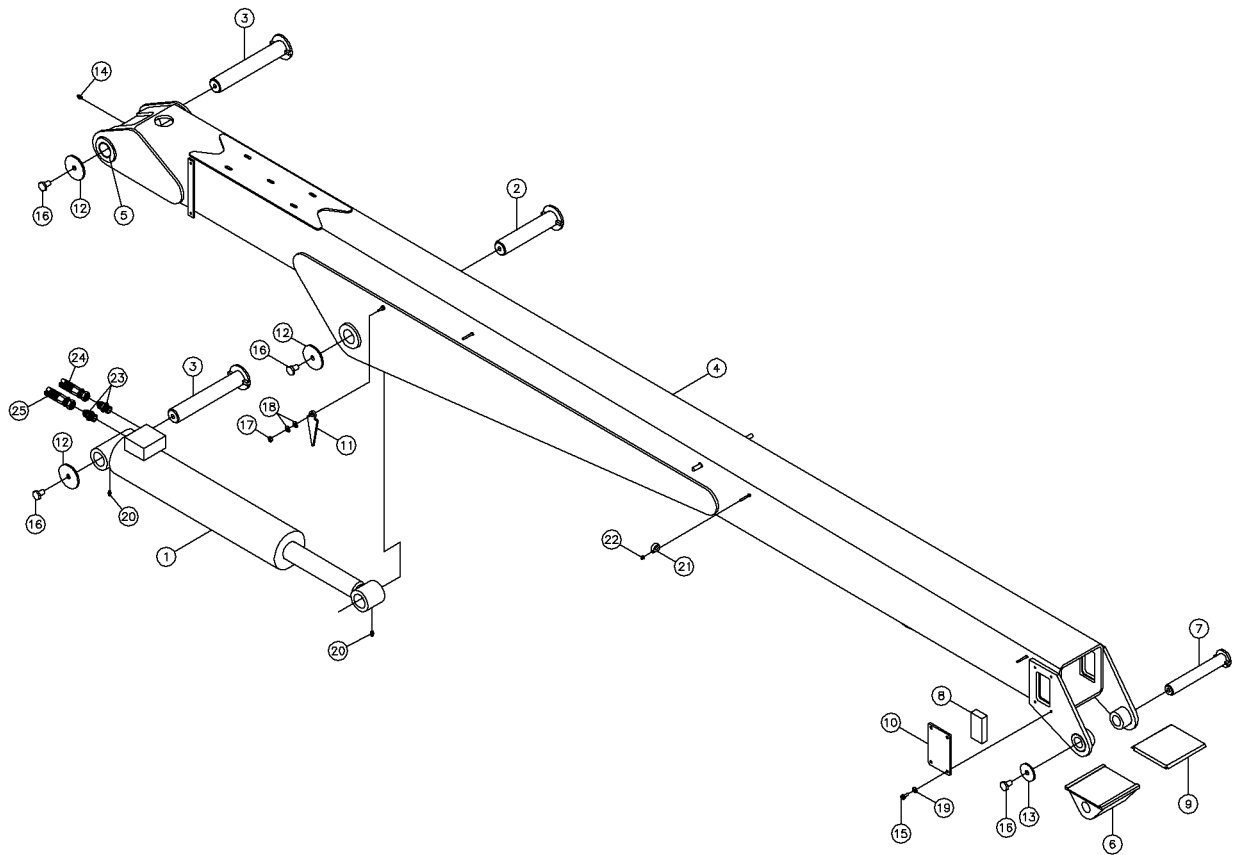

Cable Crane-Lower Boom Assy Fig 9-8

REF. NO.	*	PART NO.	DESCRIPTION	QTY.	REMARKS
1		296261759	CYL - 6.5/3.0 50.00S 70.25CC	1	Breakdown Fig 12-19
2		296261758	PIN - TYPE Y 2.00 X 10.00	1	
3		296261757	PIN - TYPE Y 2.00 X 12.50	2	
4		296261756	BOOM - LOWER WLDMT 7025	1	
5		296261755	BUSHING - STL 2.00 PIN X 1.5 LG	4	
6		296261754	TRUNNION - MCH 7025 LOWER BOOM	1	
7		296261753	PIN - TYPE Y	1	
8		296261752	WEAR PAD-RC UHMW	2	
9		296261751	WEAR PAD-DT NYL	1	
10		296256750	RETAINER -PLT-315A/425/5016	2	
11		296256749	PLATE - ANGLE PLASTIC	2	
12		296256747	RETAINER - PLT PIN 3.50 DIA	3	
13		296256744	RETAINER-PLT PIN 2.50 DIA.	1	
14		586001	ZERK-1/8" ST NPT GREASE	1	
15		351006	BOLT - 5/16 - 18 X 3/4" GR5 HEX	8	
16		366010	BOLT-5/8"-11X1" GRADE#5 HEX	4	
17		416001	NUT-3/8 NC SLTL	2	
18		235713001	WASHER-3/8 SAE HARD ZINC PLTD	4	
19		480005	WASHER-5/16 S/T LOCK	8	
20		598001	ZERK-1/4" NF ST GREASE	3	
21		296256743	SUPPORT - GP STAUFF LN-4190-PA	3	
22		103201001	NUT-1/4-20NC NYLON INSERT LOCK	3	
23		53824001	FITTING-#8M O-RING-#8M JIC ST.	2	
24		296261887	HSE - 3/8"	1	
25		296261885	HOSE - 3/8"	1	

Cable Crane-Winch/Cable/Hook Assy Fig 9-9

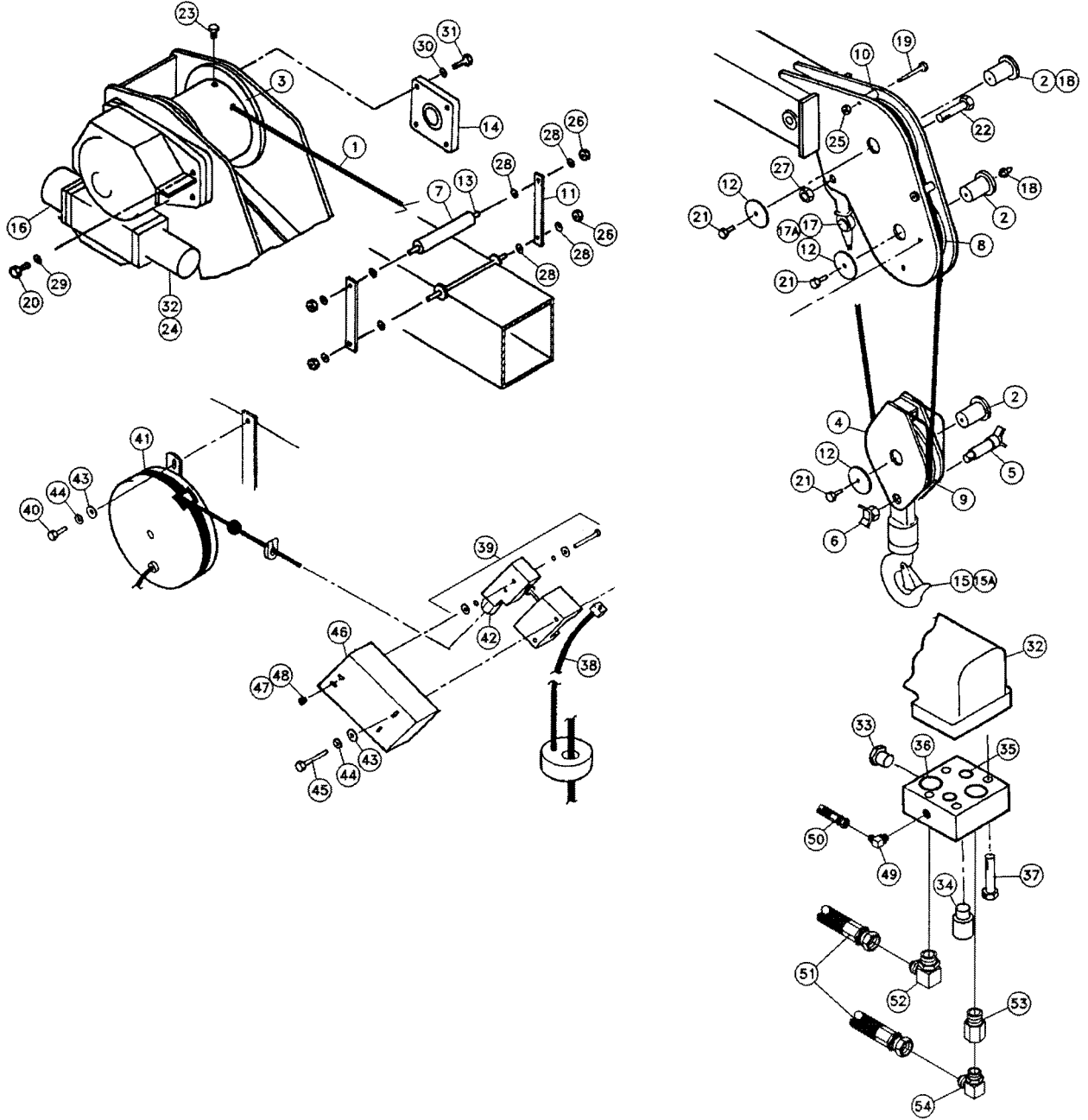

Cable Crane-Winch/Cable/Hook Assy Fig 9-9

REF. NO.	*	PART NO.	DESCRIPTION	QTY.	REMARKS
1		296261801	CABLE - W/SOCKET 1/2 X 100'	1	
2		296261802	PIN	3	
3		296261803	DRUM	1	
4		296261804	SNATCH BLOCK	1	
5		296261805	PIN	1	
6		296261806	PIN RETAINER	1	
7		296261807	GUIDE - ROLLER	1	
8		296261808	SHEAVE	2	
9		296261809	SHEAVE	1	
10		296261810	SPACER	2	
11		296261811	SIDE BAR	2	
12		296256747	RETAINER - PLT PIN 3.50 DIA	3	
13		296261813	GUIDE STUD	1	
14		296261814	BEARING	1	
15		296261815	HOOK - 7 TON	1	
15A		296261816	SAFETY LATCH ASSEMBLY	1	
16		296261817	WINCH	1	
17		296261818	HOOK - 4.5 TON	1	
17A		296261819	SAFETY LATCH ASSEMBLY	1	
18		586001	ZERK-1/8" ST NPT GREASE	3	
19		354040	BOLT-3/8-16X4" GRADE#5 HEX	2	
20		235718001	BOLT-1/2-13X2 GR8 HEX ZINC PLT	4	
21		366010	BOLT-5/8"-11X1" GRADE#5 HEX	3	
22		372044	BOLT-1"-8X4 1/2"GRADE#5 HEX	1	
23		240073001	SCREW-1/2-13X314 SOC HD ZNC	1	
24		276402001	SCREW-1/2-13X1 1/2 SHC Y ZINC	2	
25		250508001	NUT - 3/8-NC GR8 TOP LOCK Y/ZINC	2	
26		250512001	NUT- 1/2 NC GR8 TOP LOCK Y/ ZINC	4	
27		510320501	NUT-TLHEX-.1.00-8-B-YZ	1	
28		510359621	WASHER-FLATWRT-.50-.53X2.25-.25-YZ	8	
29		510335711	WASHER-LOCK-.50-.52X.87-.13-YZ	4	
30		510335715	WASHER-LOCK-.63-.65X1.08-.16-YZ	4	
31		366012	BOLT-5/8-11X1 1/4" GRADE#5 HEX	4	
32		296261820	MOTOR	1	Inc Ref No's 33-37
33		296261821	SHUTTLE VALVE	1	
34		296261822	MINI SOLENOID	1	

Cable Crane-Winch/Cable/Hook Assy (Continued) Fig 9-9

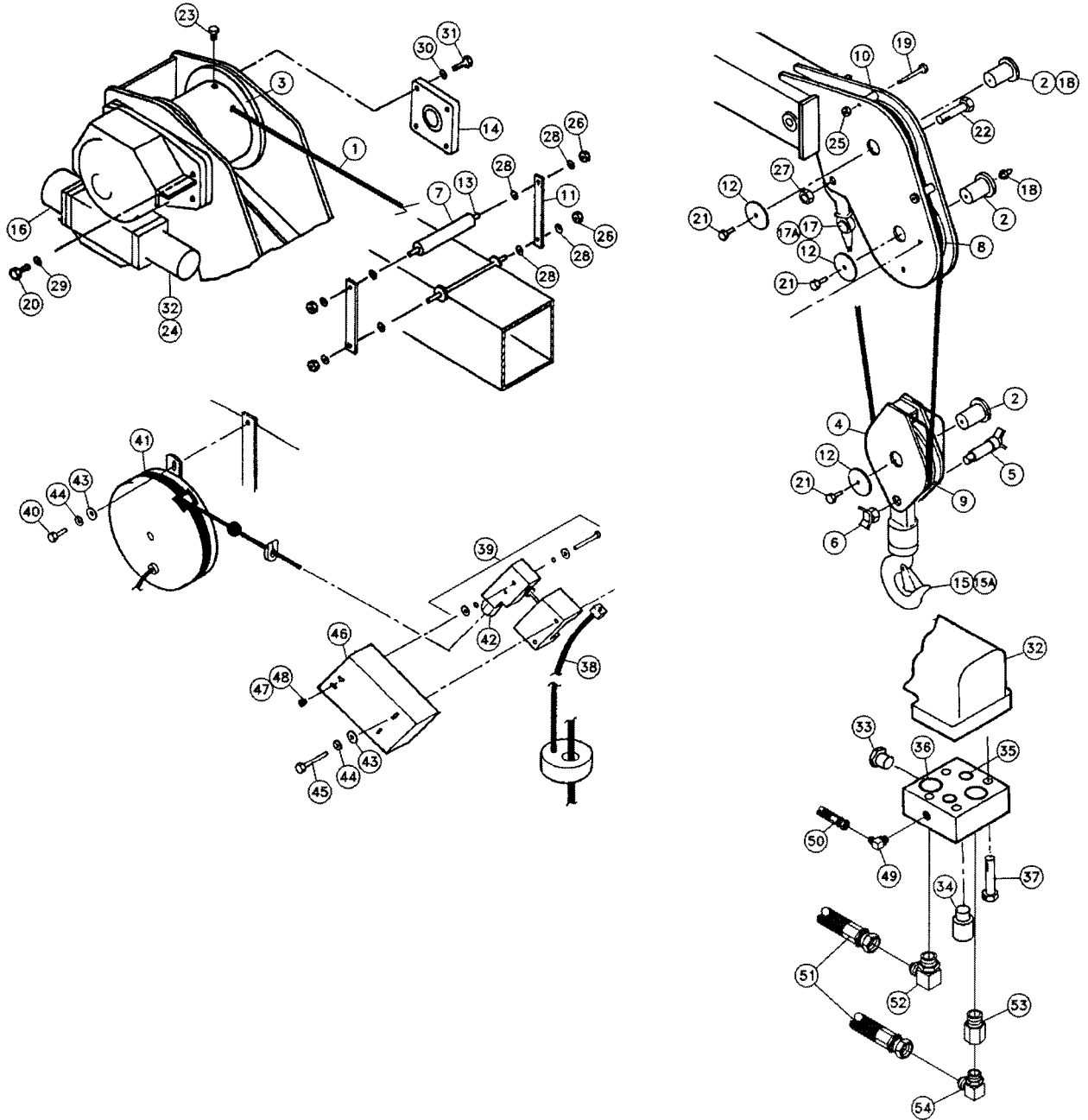

Cable Crane-Winch/Cable/Hook Assy (Continued) Fig 9-9

REF. NO.	*	PART NO.	DESCRIPTION	QTY.	REMARKS
35		296261823	O - RING	2	
36		296261824	O - RING	2	
37		296261825	CAP SCREW	4	
38		296261827	CABLE	1	
39		296261830	SWITCH	1	
40		350004	BOLT-1/4-20X1/2 HHCS GR5 PLATED	2	
41		296261829	CORD REEL	1	
42		296261828	STRAIN RELIEF	1	
43		235716001	WASHER-1/4 SAE HARD ZINC PLTD	4	
44		480003	WASHER-1/4 S/T LOCK	4	
45		510300010	SCREW-HCS-.25-20X1.00-GR5-YZ	2	
46		296261826	SWITCH COVER	1	
47		485001	WASHER-3/16 FLAT	2	
48		480001	WASHER-3/16 S/T LOCK	2	
49		59423001	FIT-4M JICX4M ADJ.90 DEG.ELBOW	1	
50		296261881	HOSE - 1/4"	1	
51		296261884	HOSE - 1/2"	2	
52		59648001	FITTING-8MJIC X 10MADJ. 90DEG.	1	
53		60930001	FITTING-10MX8F ST.SOLID REDUCER	1	
54		53837001	FITTING - 8M O-RING X 8M JIC 90 DEGREE	1	

Cable Crane-Base Valve Assy Fig 9-10r01

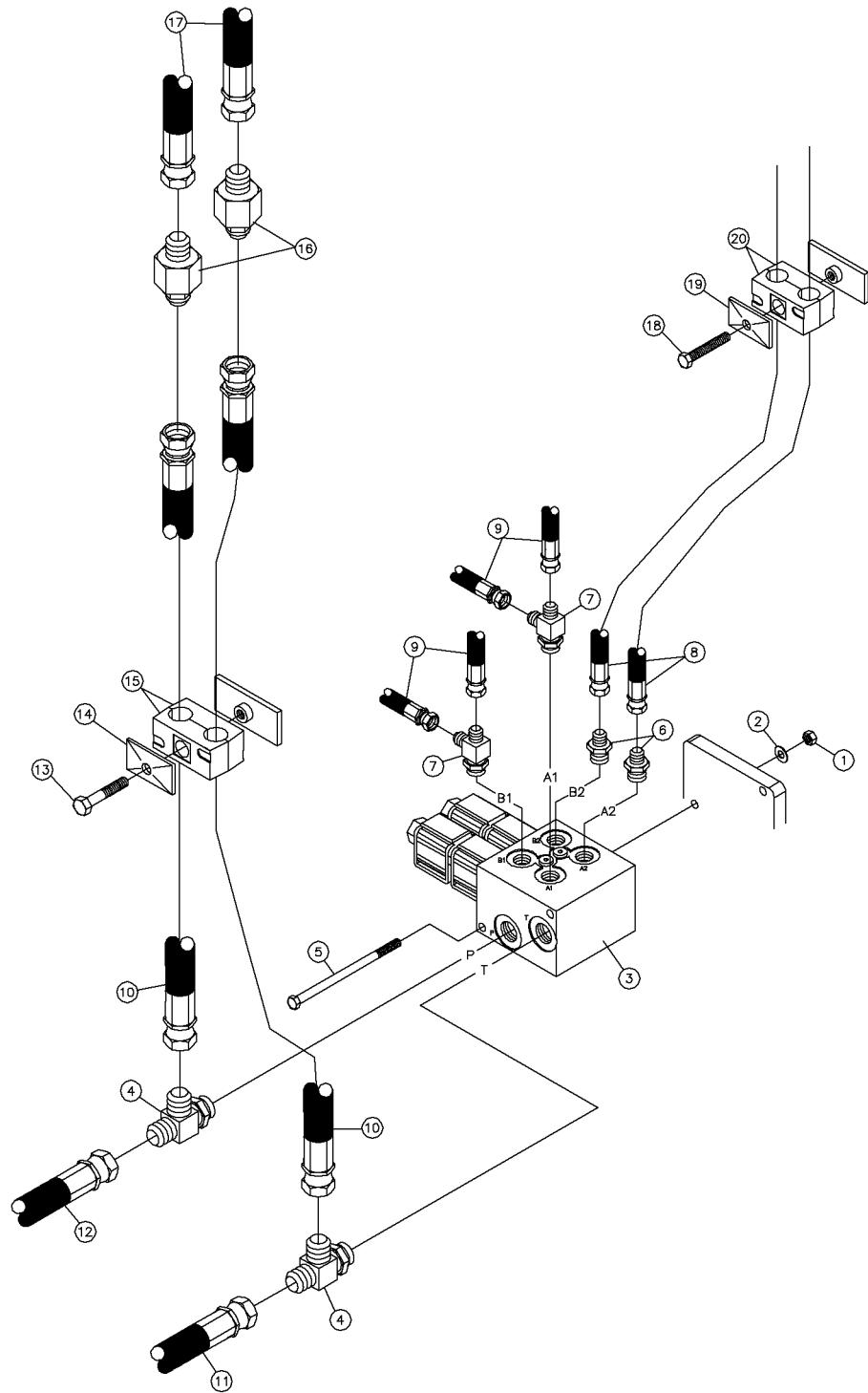

Cable Crane-Base Valve Assy Fig 9-10r01

REF. NO.	*	PART NO.	DESCRIPTION	QTY.	REMARKS
		Revision Date	October, 2004		Update In Illustration & Parts List.
1		235732001	NUT - HEX - .25 - 20 - GR8 - YZ	2	
2		235716001	WASHER - FLATSTRL - .25 -.28 X .63 - .06 - CZ	2	
3		288467001	VALVE - CRANE BASE	1	Breakdown Fig 12-7
4		81705001	FITTING-8MX8M JIC(RUN)X8M JIC	2	
5		350044	BOLT-1/4-20X4 1/2 HEXHD GR.5	2	
6		57968001	FITTING-STR-4MJ-6MORB	2	
7		82930001	FIT-6MX4M JICX4M JIC (RUN) TEE	2	
8		53843207	HOSE-1/4X76 4FS JIC 3000 PSI	2	
9		53843187	HOSE-1/4X44 4FS JIC 3000 PSI	4	
10		296258377	HOSE - .50 X 74 8FS JIC ST/ST M3K	2	
11		289128001	HOSE - 1/2 X 120 8FSJIC ST/ST 3000 PSI	1	
12		296256886	HOSE - .50 X 57 8 FS JIC ST/ST M3K	1	
13		72062003	BOLT-5/16-18X1 3/4	1	
14		72062005	PLATE-TOP CLAMP	1	
15		72062007	CLAMP - PAIR, 1/2 HYD HOSE	1	
16		296261563	FITTING - LIVE SWIVEL - 8MJ X 8NJ	2	
17		296258368	HOSE - .50 X 32 8FS JIC ST/ST M3K	2	
18		351012	BOLT-5/16"-18X1 1/4"GR5 HEX REF T03059	2	
19		67846003	PLATE-TWIN COVER	2	
20		67846005	CLAMP-PAIR-1/2" PIPE/1/4" HYD. HOSE	2	

Cable Crane-Base Valve Assy Fig 9-10

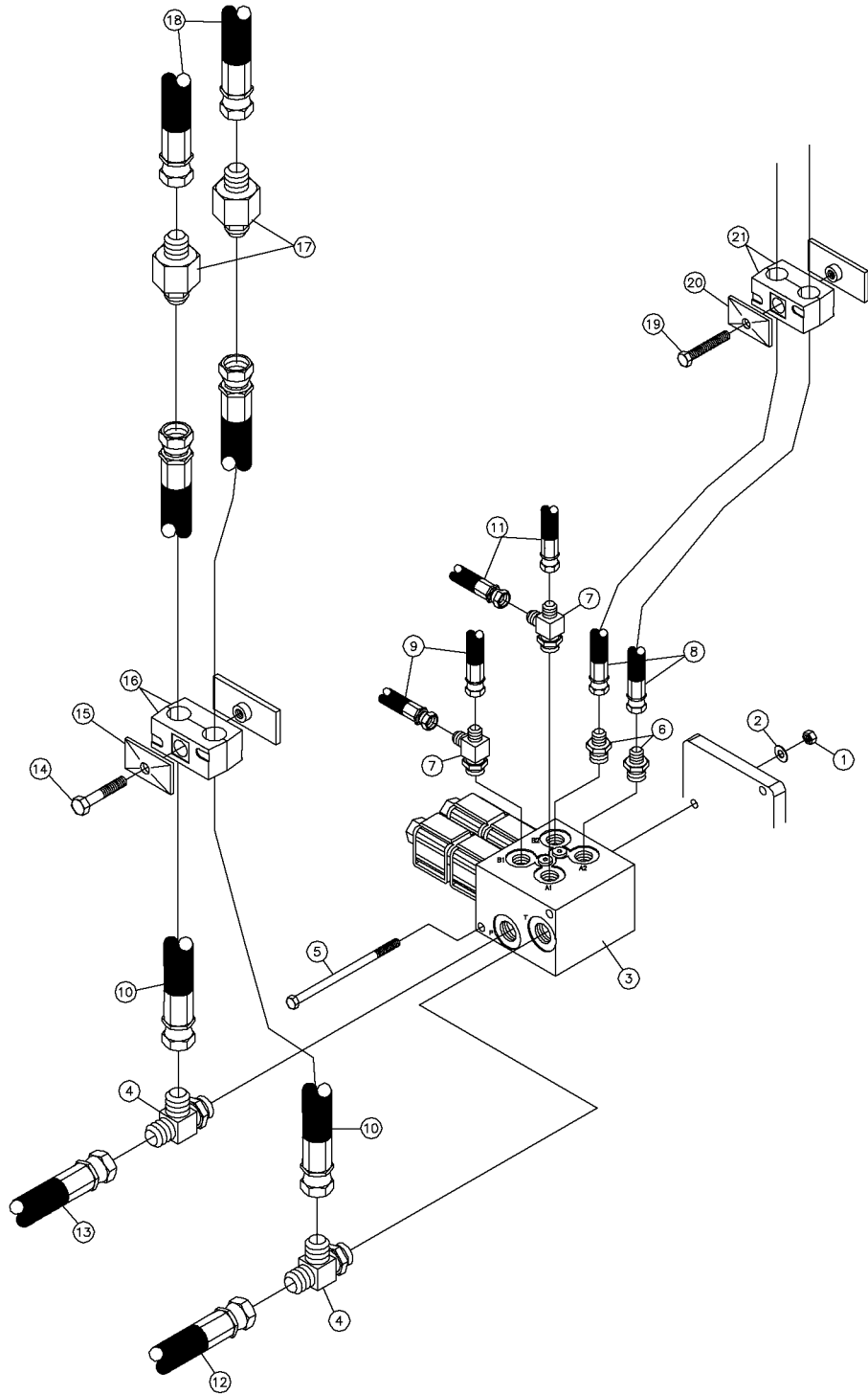

Cable Crane-Base Valve Assy Fig 9-10

REF. NO.	*	PART NO.	DESCRIPTION	QTY.	REMARKS
1		235732001	NUT-1/4-20 GR8 ZINC PLTD	2	
2		235716001	WASHER-1/4 SAE HARD ZINC PLTD	2	
3		288467001	VALVE - CRANE BASE	1	Breakdown Fig12-7
4		81705001	FITTING-8MX8M JIC(BCH)X8M JIC	2	
5		350044	BOLT-1/4-20X4 1/2 HEXHD GR.5	2	
6		57968001	FITTING-STR-4MJ-6MORB	2	
7		82930001	FIT-6MX4M JICX4M JIC (BCH) TEE	2	
8		53843489	HOSE-1/4X100 4FS JIC 3000 PSI	2	
9		53843189	HOSE-1/4X24 4FS JIC 3000 PSI	2	
10		296258377	HOSE - .50 X 74 8FS JIC ST/ST M3K	2	
11		53843211	HOSE-1/4X20 4FS JIC 3000 PSI	2	
12		289128001	HOSE - 1/2 X 120 8FSJIC ST/ST 3000 PSI	1	
13		296256886	HOSE - .50 X 57 8 FS JIC ST/ST M3K	1	
14		72062003	BOLT-5/16-18X1 3/4	1	
15		72062005	PLATE-TOP CLAMP	1	
16		72062007	CLAMP - PAIR, 1/2 HYD HOSE	1	
17		296261563	FITTING - LIVE SWIVEL - 8MJ X 8NJ	2	
18		296258368	HOSE - .50 X 32 8FS JIC ST/ST M3K	2	
19		351012	BOLT-5/16"-18X1 1/4"GR5 HEX	2	
20		67846003	PLATE-TWIN COVER	2	
21		67846005	CLAMP-TWIN (PAIR) 3/8 HYD. HOSE	2	

Cable Crane-Control Valve Assy Fig 9-11

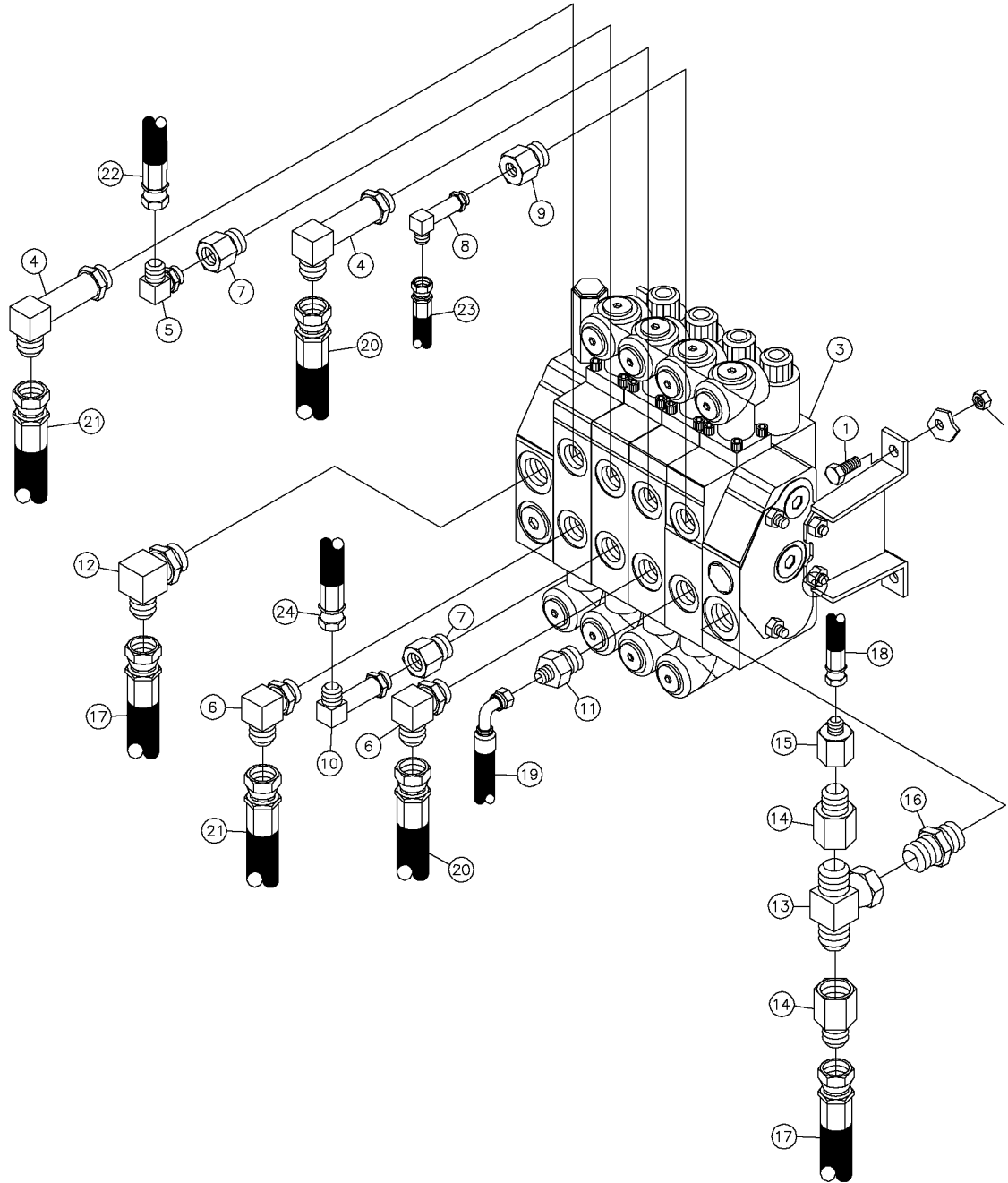

Cable Crane-Control Valve Assy Fig 9-11

REF. NO.	*	PART NO.	DESCRIPTION	QTY.	REMARKS
1		351006	BOLT - 5/16 - 18 X 3/4" GR5 HEX	4	
2		104212001	NUT-5/16-18 NYLON INSERT LOCK	4	
3		283003001	FOUR SECTION VALVE - CRANE CONTROLS	1	Breakdown Fig 12-1
4		278044001	FITTING -8MJ X 8MOR 90 - LONG	2	
5		59426001	FITTING - 6M JIC X 6M O-RING ADJ 90 ELBOW	1	
6		53837001	FITTING - 8M O-RING X 8M JIC 90 DEGREE	2	
7		81925001	FITTING-8MX6F STRAIGHT	2	
8		249977001	FITTING - 4MOR X 4MJIC 90 LONG	1	
9		98125001	FITTING-8M ORING X4F ORING STR	1	
10		65570001	6M X 6M JIC 90 DEGREE LONG	1	
11		53657001	FITTING-8M OR X 4M JIC ST.	1	
12		59648001	FITTING-8MJIC X 10MADJ. 90DEG.	1	
13		65566001	10FS JIC BCHX10MJICX10MJIC TEE	1	
14		86670001	FITTING-ADAPT 10FJICX8MJIC RED	2	
15		54385001	FITTING-8F JICX4MJIC REDUCER	1	
16		53827001	FITT.-#10M O-RING-#10M JIC ST.	1	
17		296258368	HOSE - .50 X 32 8FS JIC ST/ST M3K	2	
18		296261881	HOSE - 1/4"	1	
19		296261882	HOSE - 1/4"	1	
20		296261883	HOSE 1/2"	2	
21		296261884	HOSE - 1/2"	2	
22		296261885	HOSE - 3/8"	1	
23		296261886	HOSE - 1/4"	1	
24		296261887	HOSE - 3/8"	1	

Crane Base Lift Cylinder Assy Fig 9-12

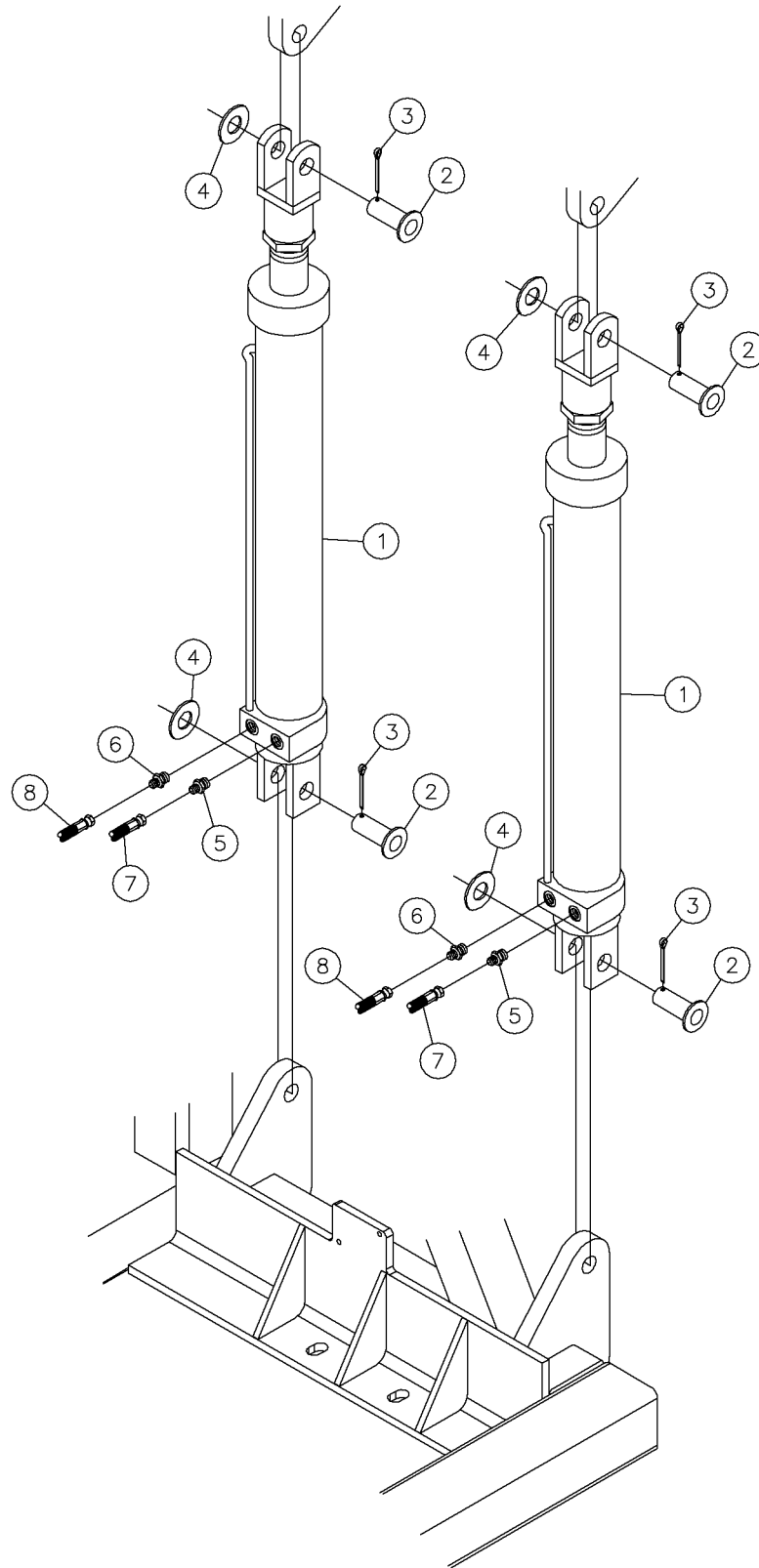

Crane Base Lift Cylinder Assy Fig 9-12

REF. NO.	*	PART NO.	DESCRIPTION	QTY.	REMARKS
1		296258260	CYLINDER - 3" X 24" ADJUSTABLE CLEVIS	2	Breakdown Fig 12-13
3		20667001	HAIR PIN COTTER - .177 WIRE	4	
4		238892001	WASHER-1" HARDENED FLAT ZY	4	
5		57968001	FITTING-STR-4MJ-6MORB	2	
6		131009001	FITTING-4MJICX6MORING ST.062R	2	
7		53843211	HOSE-1/4X20 4FS JIC 3000 PSI	2	
8		53843189	HOSE-1/4X24 4FS JIC 3000 PSI	1	

Water Line Assy Fig 10-1r01

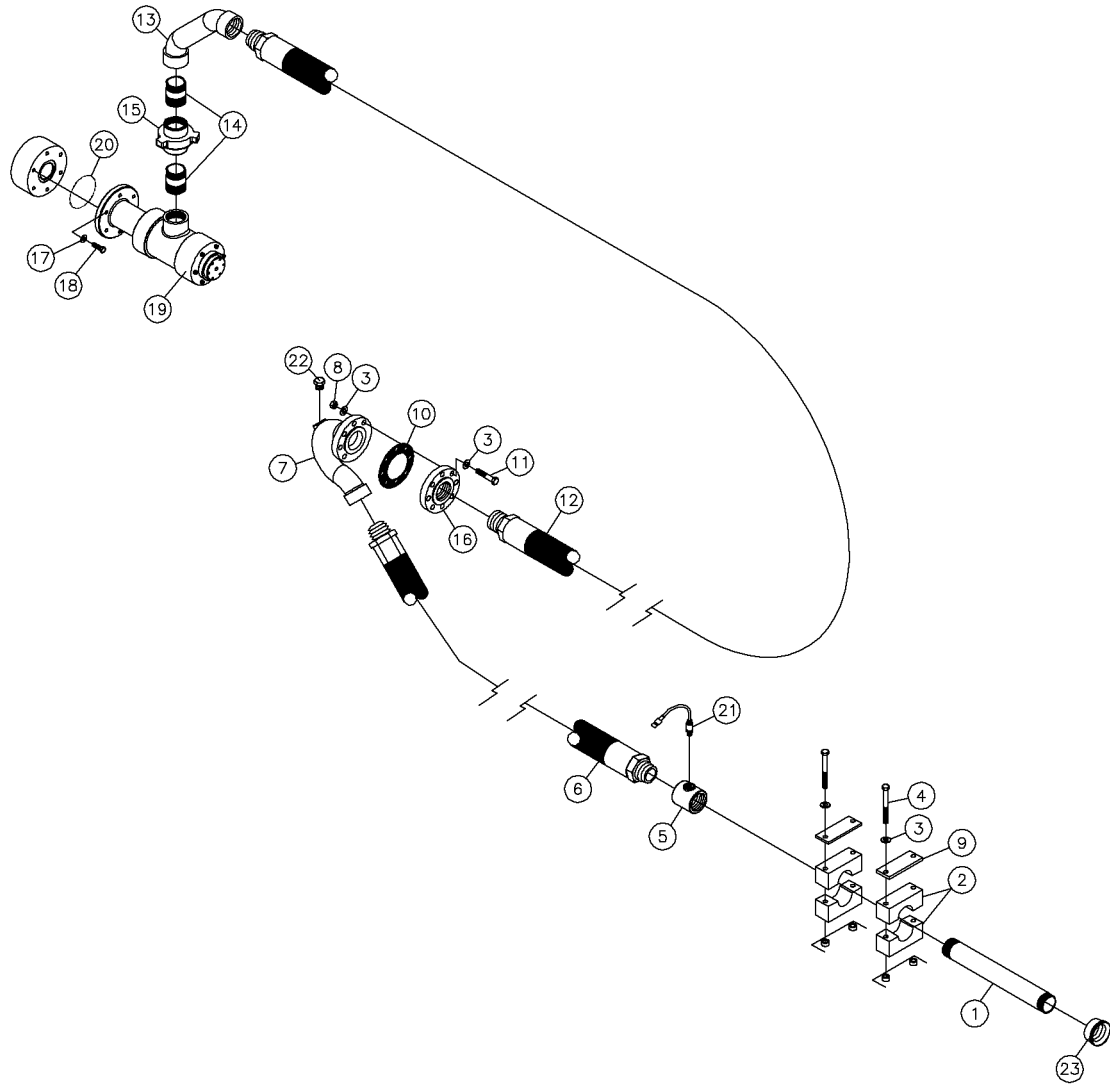

Water Line Assy Fig 10-1r01

REF. NO.	*	PART NO.	DESCRIPTION	QTY.	REMARKS
1		296258329	NIPPLE - 3" X 24" SCH80	1	
2		292770001	CLAMP - HEAVY SERIES - 8S	4	
3		235717001	WASHER-3/4 FLAT HARDENED YELLOW ZINC	20	
4		385070	3/4-10X7" GRADE#8HEX BOLT	4	
5		296256869	PIPE - WATER PRESSURE SENSOR	1	
6		292842001	HOSE - 3" X 100" - 48MNPT/48MNPT	1	
7		292921001	WELDMENT - 3" FLANGE/ELBOW	1	
8		235739001	NUT-3/4-10 GR8 ZINC PLTD	8	
9		292769001	BAR - CLAMP HOLDER	2	
10		296264775	GASKET	1	
11		238881001	BOLT-3/4-10 X 4 HHCS GR8 ZY	8	
12	*	292841001	HOSE - 3" X 400" 48MNPT/48MNPT	1	
13		296261557	WELDMENT - 3" WATER ATTACHMENT	1	
14		296258307	NIPPLE - 3" CLOSE SCH80	2	
15		296252082	UNION - HAMMER - 3" - FIG 200	1	Breakdown Fig 10-2
16		296261515	ASSY - 3" FLANGE/NUT/BOLT/GASKET 600LB	1	Inc Ref No 10
17		235715001	WASHER-5/8 SAE HARD ZINC PLTD	6	
18		145645001	BOLT - 5/8 - 11 X 2 GR.8 PLATED	6	
19		228213001	SWIVEL-ROTATING HEAD MUD	1	Breakdown Fig 12-34
20		296256839	O - RING #358	1	
21		283060001	SENSOR-MUD PRESSURE	1	
22		81214001	PLUG- 16M	1	
23		296256722	SUB - 3" FEMALE HAMMER UNION	1	

Water Line Assy Fig 10-1

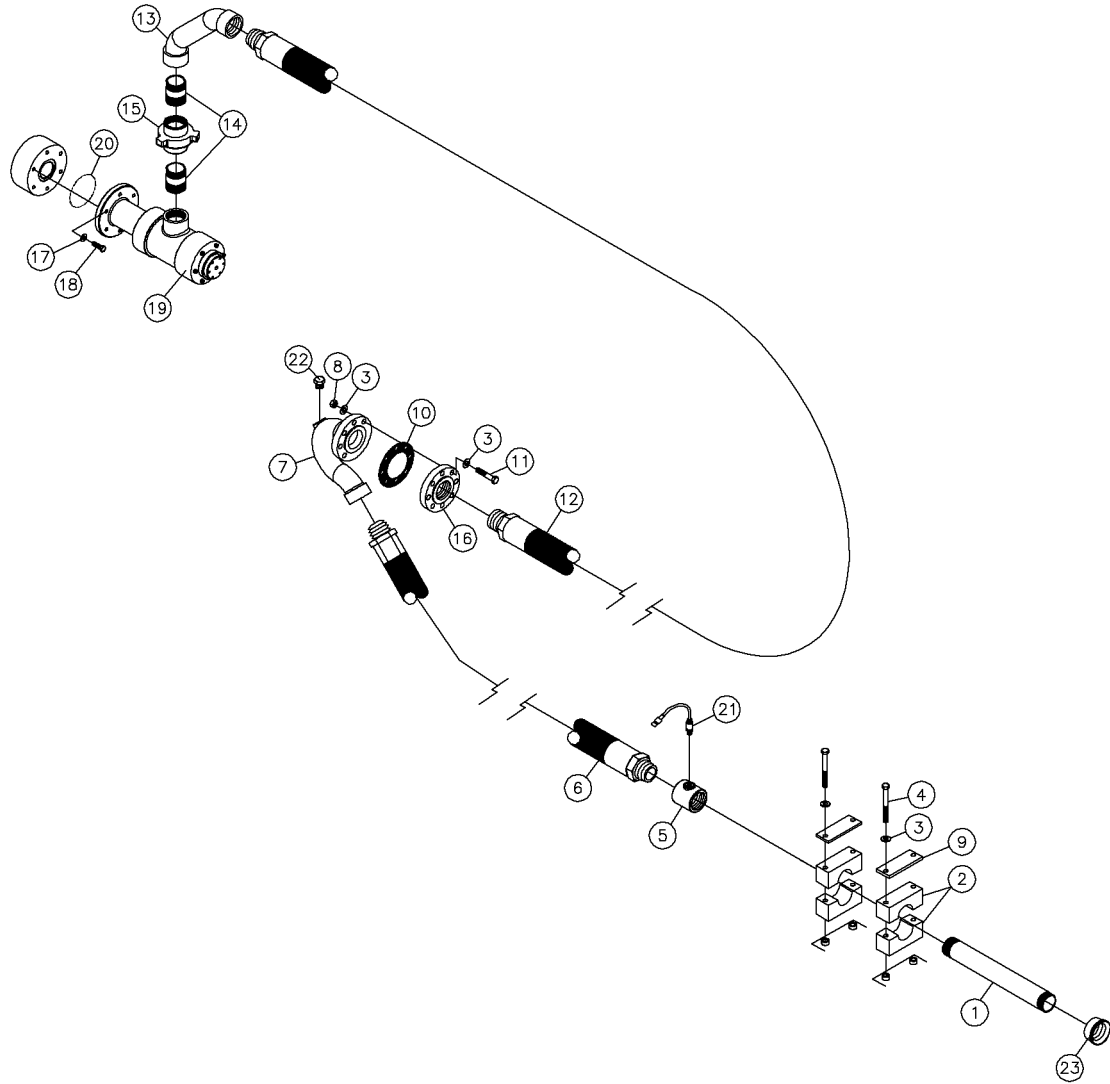

Water Line Assy Fig 10-1

REF. NO.	*	PART NO.	DESCRIPTION	QTY.	REMARKS
1		296258329	NIPPLE - 3" X 24" SCH80	1	
2		292770001	CLAMP - HEAVY SERIES - 8S	4	
3		235717001	WASHER-3/4 FLAT HARDENED YELLOW ZINC	20	
4		385070	3/4-10X7" GRADE#8HEX BOLT	4	
5		296256869	PIPE - WATER PRESSURE SENSOR	1	
6		292842001	HOSE - 3" X 100" - 48MNPT/48MNPT	1	
7		292921001	WELDMENT - 3" FLANGE/ELBOW	1	
8		235739001	NUT-3/4-10 GR8 ZINC PLTD	8	
9		292769001	BAR - CLAMP HOLDER	2	
10		296264775	GASKET	1	
11		238881001	BOLT-3/4-10 X 4 HHCS GR8 ZY	8	
12		282841001	HOSE - 3" X 400" 48MNPT/48MNPT	1	
13		296261557	WELDMENT - 3" WATER ATTACHMENT	1	
14		296258307	NIPPLE - 3" CLOSE SCH80	2	
15		296252082	UNION - HAMMER - 3" - FIG 200	1	Breakdown Fig 10-2
16		296261515	ASSY - 3" FLANGE/NUT/BOLT/GASKET 600LB	1	Inc Ref No 10
17		235715001	WASHER-5/8 SAE HARD ZINC PLTD	6	
18		145645001	BOLT - 5/8 - 11 X 2 GR.8 PLATED	6	
19		228213001	SWIVEL-ROTATING HEAD MUD	1	Breakdown Fig 12-34
20		296256839	O - RING #358	1	
21		283060001	SENSOR-MUD PRESSURE	1	
22		81214001	PLUG- 16M	1	
23		296256722	SUB - 3" FEMALE HAMMER UNION	1	

Water-Hammer Union Components-3" Fig 10-2

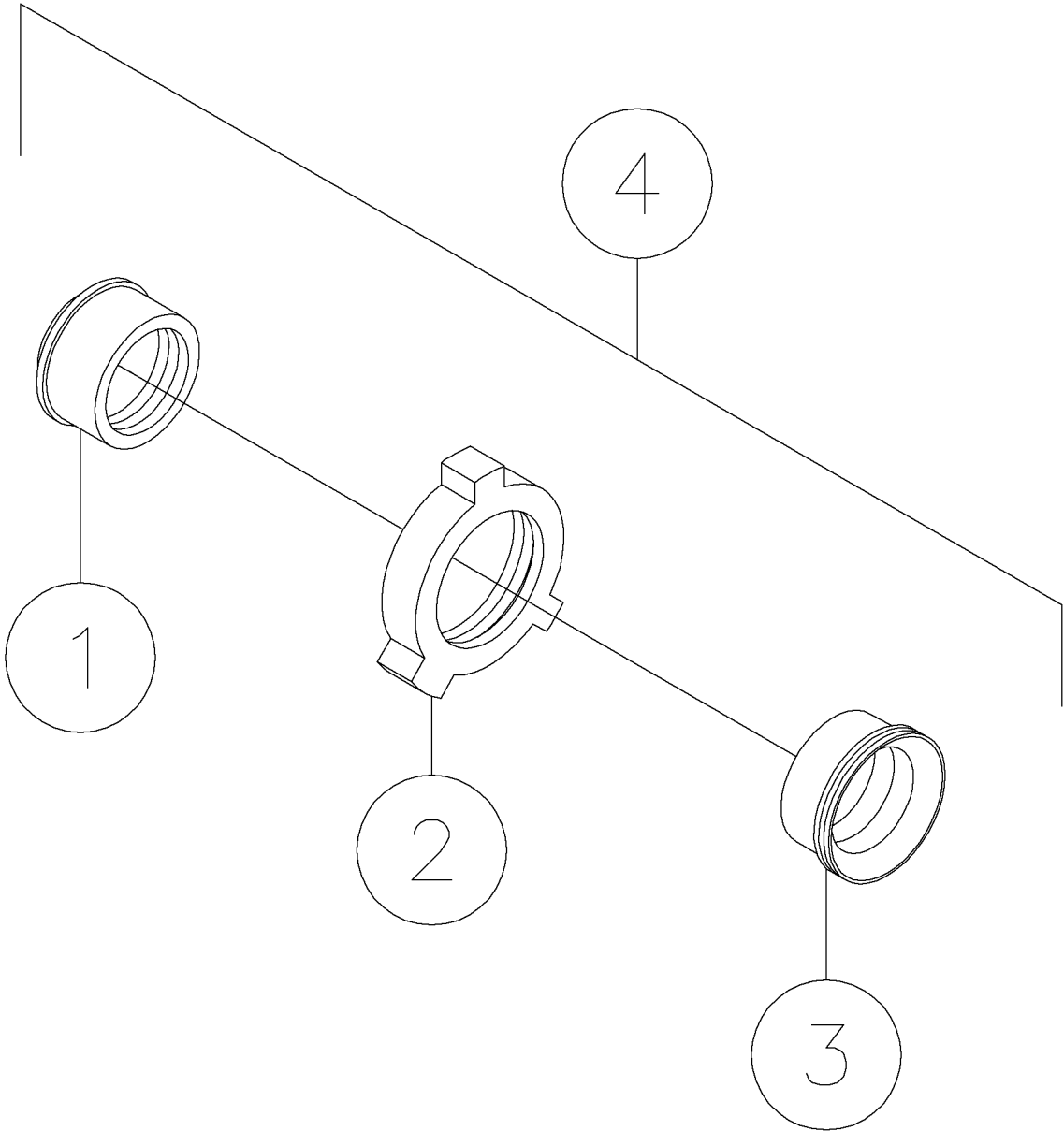

Water-Hammer Union Components-3" Fig 10-2

REF. NO.	*	PART NO.	DESCRIPTION	QTY.	REMARKS
1		296256723	SUB - 3" MALE HAMMER UNION	1	
2		296256721	WINGNUT - 3" HAMMER UNION	1	
3		296256722	SUB - 3" FEMALE HAMMER UNION	1	
4		296252082	UNION - HAMMER - 3" - FIG 200	1	Complete

Dump Valve Assy Fig 10-3

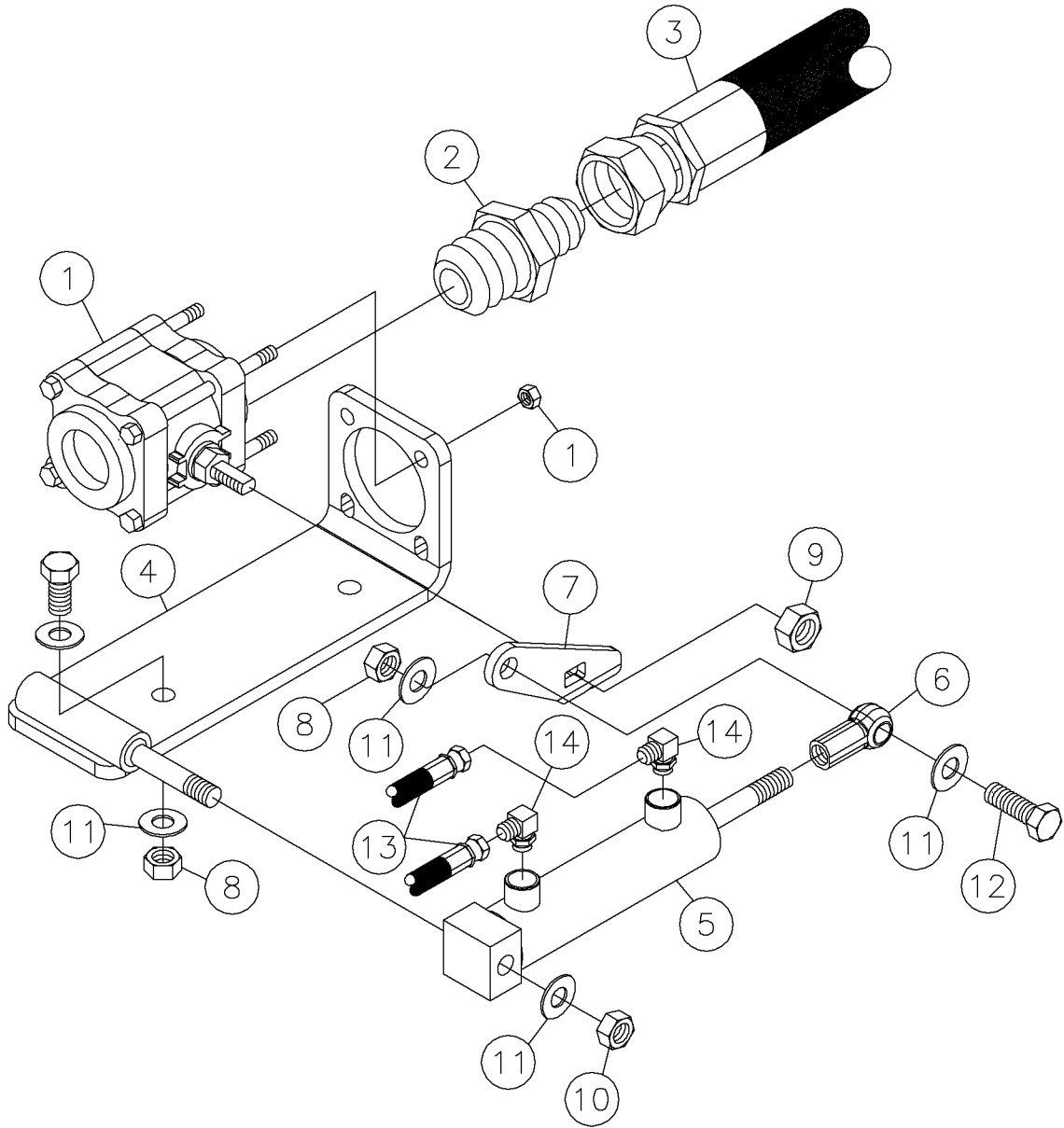

Dump Valve Assy Fig 10-3

REF. NO.	*	PART NO.	DESCRIPTION	QTY.	REMARKS
		Revision Date	June, 2002		Add New Figure
1		287053001	VALVE - 1-1/2" BALL (2200 PSI)	1	Breakdown Fig 12-49
2		53835001	#16M O-RING-#16M JIC 45 DEG.	1	
3		53846421	HOSE-1X96 16FS JIC 3000 PSI	1	
4		270225001	SUPPORT-BALL VALVE	1	
5		287591001	CYLINDER - 1 X 3-1/2	1	Breakdown Fig 12-50
6		224291001	BALL JOINT-1/2-20 FEMALE THDS.	1	
7		278224001	LEVER - BALL VALVE	1	
8		250512001	NUT- 1/2 NC Gr8 TOP LOCK Y/ ZINC	4	
9		250514001	NUT -5/8NC JAM Y/ZINC	1	
10		3888001	NUT-1/2 N.F. HEX JAM REF T07887	1	
11		485025	WASHER-1/2 FLAT-HARDENED-ZINC	4	
12		235721001	BOLT-1/2-13X1 1/2 GR8 ZINC PLT	1	
13		53843213	HOSE-1/4X140 4FS JIC 3000 PSI	2	
14		59423001	FIT-4M JICX4M ADJ.90 DEG.ELBOW	2	

Safety-Voltage Stake Assy Fig 11-1r01

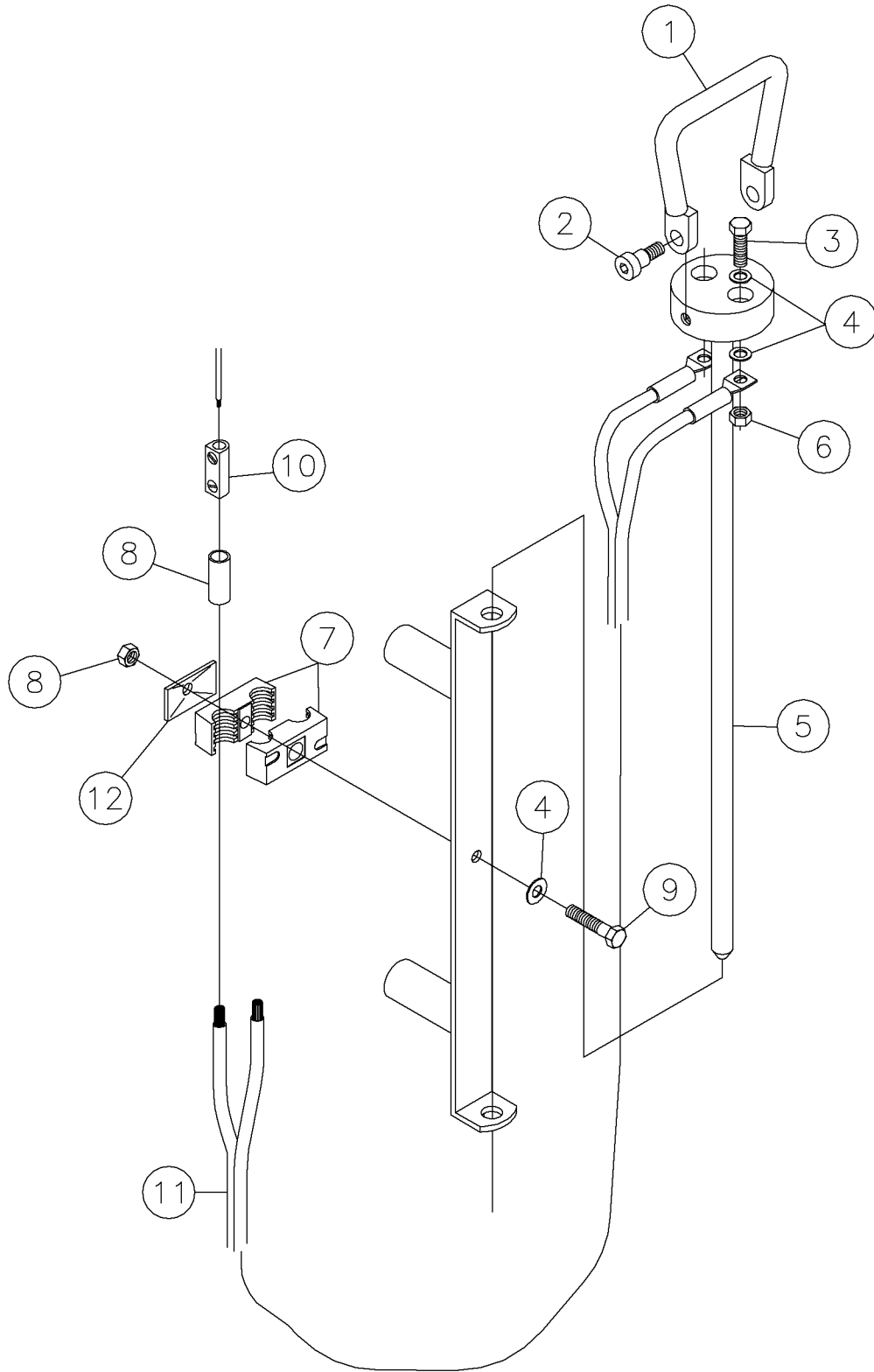

Safety-Voltage Stake Assy Fig 11-1r01

REF. NO.	*	PART NO.	DESCRIPTION	QTY.	REMARKS
		Revision Date	June, 2002		Revised Drawing
1		234164001	HANDLE-VOLTAGE STAKE	1	
2		240056001	SCREW-1/2-13X1/2 NCSOC HD ZNC	2	
3		235736001	BOLT-3/8-16X1 1/4 ZINC PLTD	2	
4		235713001	WASHER-3/8 SAE HARD ZINC PLTD	4	
5		234167001	STAKE-VOLTAGE	1	
6		235725001	NUT-3/8-16 GR8 ZINC PLTD	3	
7		900035003	DOUBLE HOSE CLAMP PLATE 3/8	1	
8		208065001	SHRINK TUBE-3/4ID COMMERCL GRD	2	
9	*	248031001	BOLT-5/16-18X1 1/4 GR8 ZINC PL	1	
10		904355001	CONNECTOR	2	
11		217967001	CORD ASS'Y VOLTAGE STAKE	1	Inc Ref No's 1-6, 11
	*	67846003	PLATE-TWIN COVER	3	

Safety-Voltage Stake Assy Fig 11-1

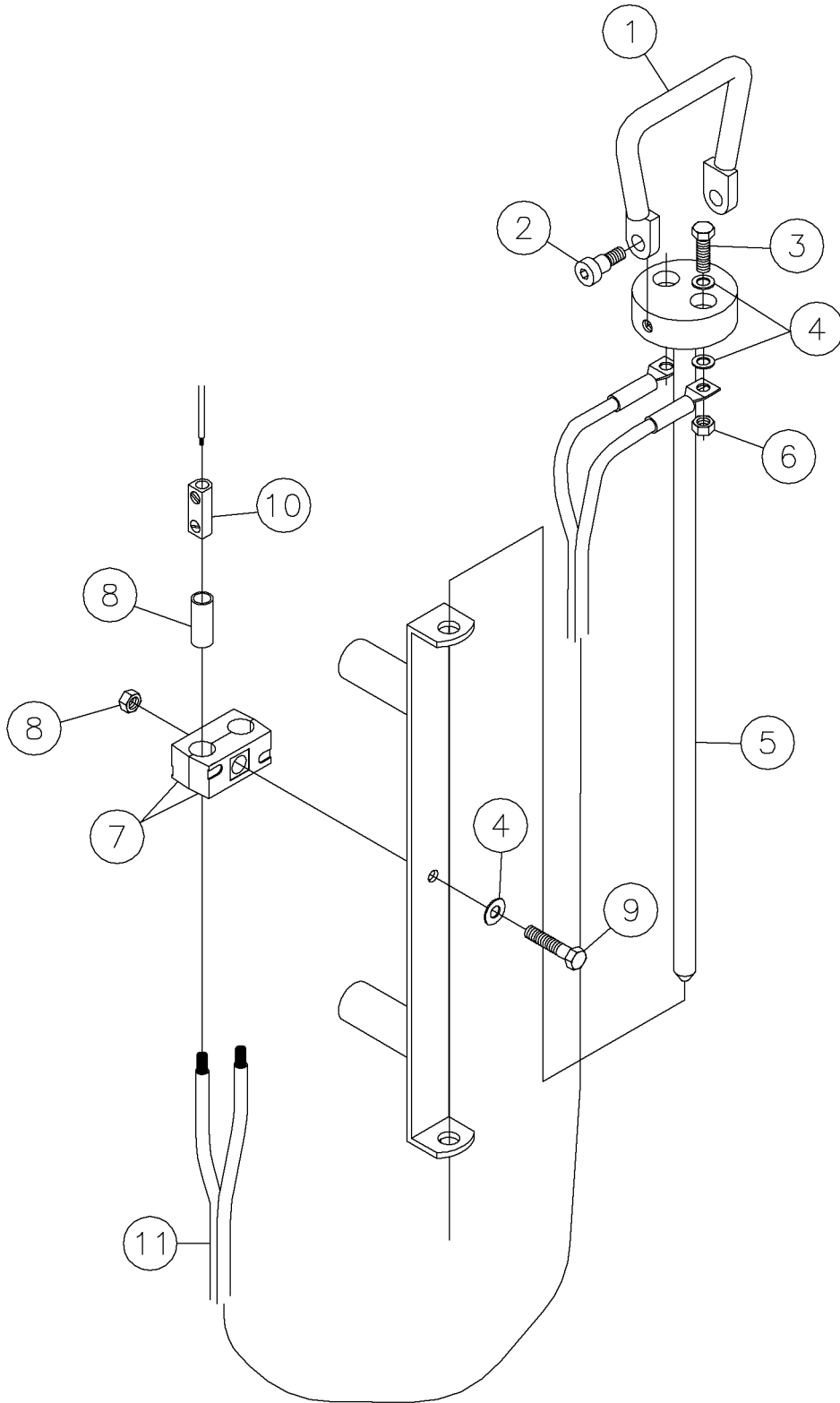

Safety-Voltage Stake Assy Fig 11-1

REF. NO.	*	PART NO.	DESCRIPTION	QTY.	REMARKS
1		234164001	HANDLE-VOLTAGE STAKE	1	
2		240056001	SCREW-1/2-13X1/2 NCSOC HD ZNC	2	
3		235736001	BOLT-3/8-16X1 1/4 ZINC PLTD	2	
4		235713001	WASHER-3/8 SAE HARD ZINC PLTD	4	
5		234167001	STAKE-VOLTAGE	1	
6		235725001	NUT-3/8-16 GR8 ZINC PLTD	3	
7		900035003	DOUBLE HOSE CLAMP PLATE 3/8	1	
8		208065001	SHRINK TUBE-3/4ID COMMERCIAL GRD	2	
9		235720001	BOLT-3/8-16X1 3/4 6R8 ZINC PLT	1	
10		904355001	CONNECTOR	2	
11		217967001	CORD ASS'Y VOLTAGE STAKE	1	Inc Ref No's 1-6, 11

Safety Features-Gloves Boots Cones Fig 11-2

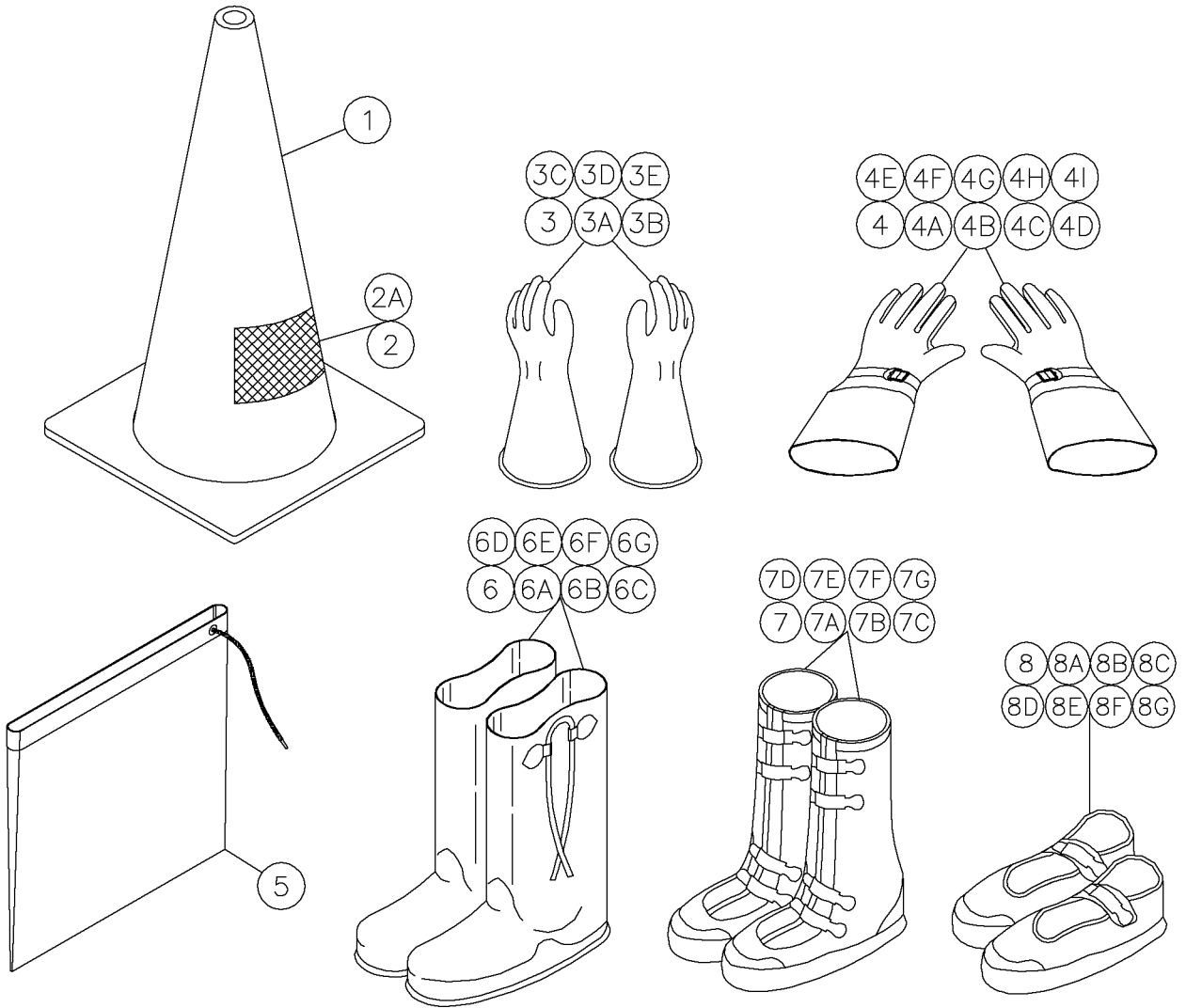

Safety Features-Gloves Boots Cones Fig 11-2

REF. NO.	*	PART NO.	DESCRIPTION	QTY.	REMARKS
1		904541001	CONES-ORANGE PVC	4	
2		70000530	DECAL-DANGER	4	
2A		70001530	DECAL-DANGER	4	
3		210782001	GLOVES-SIZE 9 RUBBER INSULATE	1	
3A		210782005	GLOVES-SIZE 9 1/2 RUBBER INSUL	1	
3B		210782003	GLOVES-SIZE 10 RUBBER INSULATE	1	
3C		210782007	GLOVE-SIZE 11 RUBBER INSULATED	1	
3D		210782009	GLOVE-SIZE 12 RUBBER INSULATED	1	
4		210783001	GLOVES-SIZE 9 LEATHER PROTECT	1	
4A		210783005	GLOVES SIZE 9 1/2 LEATHER PROT	1	
4B		210783003	GLOVES-SIZE 10 LEATHER PROTECT	1	
4C		210783007	GLOVE-SIZE 11 LEATHER PROTECT	1	
4D		210783008	GLOVE-SIZE 12 LETHER PROTECT	1	
4E		210781001	GLOVE KIT-SIZE 9	1	Inc 1pr Rubber Gloves 1pr Leather Gloves & 1 Glove Bag Ref No 5
5		210784001	BAG-GLOVE	1	
6		210780009	BOOTS-SIZE 9 OVER-THE-SHOE	1	
6A		210780001	BOOTS-SIZE 10 OVER-THE-SHOE	1	
6B		210780003	BOOTS-SIZE 11 OVER-THE-SHOE	1	
6C		210780005	BOOTS-SIZE 12 OVER-THE SHO	1	
6D		210780007	BOOTS-SIZE 13 OVER-THE-SHOE	1	
6E		210780011	BOOTS-SIZE 14 OVER-THE-SHOE	1	
7		279118001	BOOT - 4 BUCKLE SIZE 9	1	
7A		279118002	BOOT - 4 BUCKLE SIZE 10	1	
7B		279118003	BOOT 4 BUCKLE SIZE 11	1	
7C		279118004	BOOT - 4 BUCKLE SIZE 12	1	
7D		279118005	BOOT - 4 BUCKLE SIZE 13	1	
7E		279118006	BOOT - 4 BUCKLE SIZE 14	1	
8		279119001	BOOT - ANKLE RUBBER SIZE9	1	
8A		279119002	BOOT - ANKLE RUBBER SIZE 10	1	
8B		279119003	BOOT - ANKLE RUBBER SIZE 11	1	
8C		279119004	BOOT - ANKLE RUBBER SIZE 12	1	
8D		279119005	BOOT - ANKLE RUBBER SIZE 13	1	
8E		279119006	BOOT - ANKLE RUBBER SIZE 14	1	
4F		224979001	GLOVE KIT-SIZE 9 1/2	1	Inc 1pr Rubber Gloves 1pr Leather Gloves & 1 Glove Bag Ref No 5
4G		210785001	GLOVE KIT-SIZE 10	1	Inc 1pr Rubber Gloves 1pr Leather Gloves & 1 Glove Bag Ref No 5
4H		224990001	GLOVE KIT-SIZE 11	1	Inc 1pr Rubber Gloves 1pr Leather Gloves & 1 Glove Bag Ref No 5
4I		224991001	GLOVE KIT-SIZE 12	1	Inc 1pr Rubber Gloves 1pr Leather Gloves & 1 Glove Bag Ref No 5
6F		210780013	BOOTS-SIZE 15 OVER-THE-SHOE	1	
6G		210780015	BOOTS-SIZE 16 OVER-THE-SHOE	1	
7F		279118007	BOOT - 4 BUCKLE SIZE 15	1	
7G		279118008	BOOT - 4 BUCKLE SIZE 16	1	
8F		279119007	BOOT - ANKLE RUBBER SIZE 15	1	
8G		279119008	BOOT - ANKLE RUBBER SIZE 16	1	

Components-Valve-Crane Control Fig 12-1r01

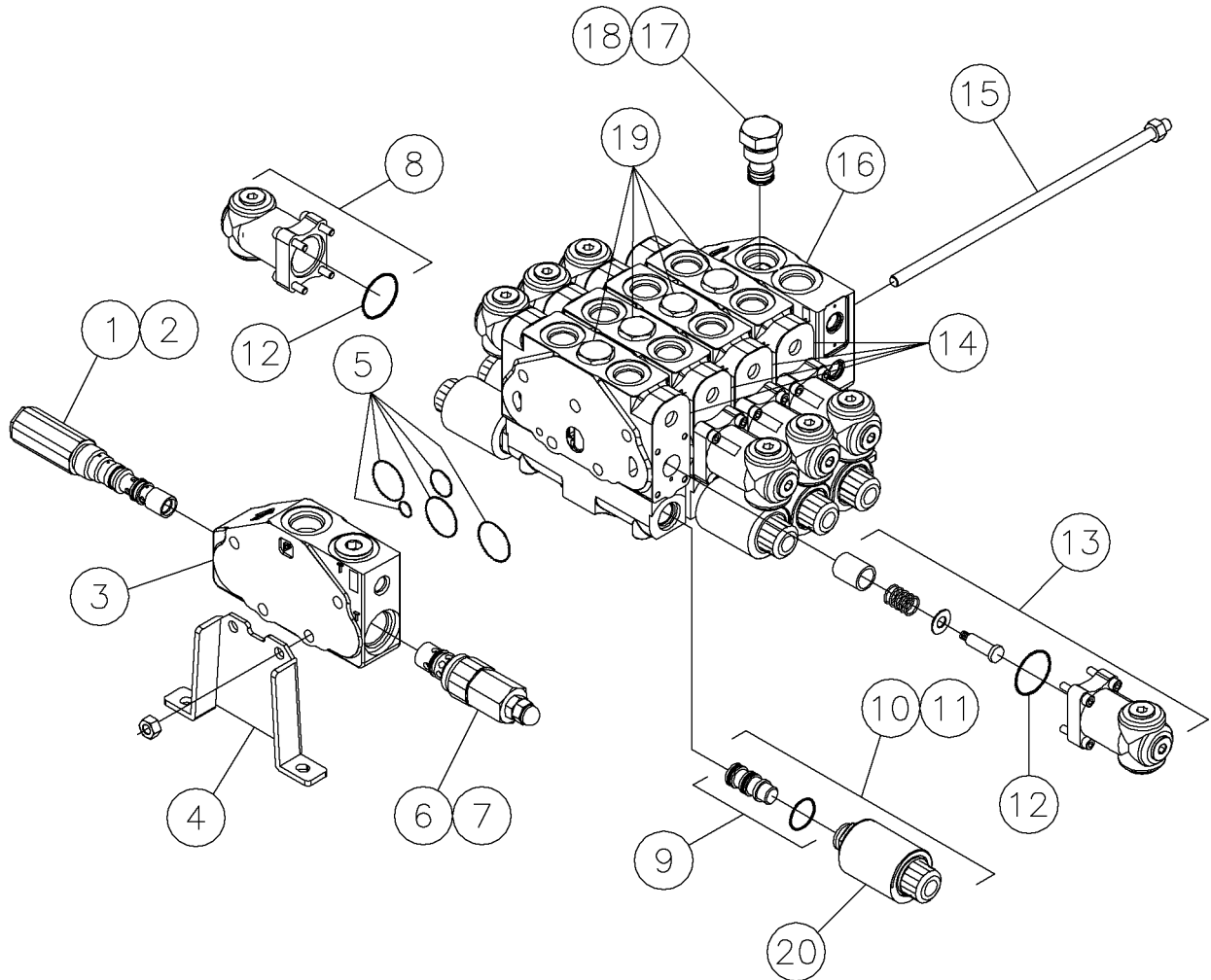

Components-Valve-Crane Control Fig 12-1r01

REF. NO.	*	PART NO.	DESCRIPTION	QTY.	REMARKS
		Revision Date	October, 2004		Update In Illustration & Parts List.
1		296261938	VALVE - PRESSURE REDUCING	1	
2		296261939	SEAL KIT	1	
3		296261940	COVER - INLET ASSEMBLY	1	Inc One Of Ref No's 1 ,2 ,6 ,7
4		296261941	BRACKET KIT	1	Complete
5		296261942	SEAL KIT	5	
6		296261943	RELIEF CARTRIDGE	1	
7		296261944	SEAL KIT	1	
8		296261945	SOLENOID ACTUATOR KIT	4	
9		296261946	CARTRIDGE	8	
10		296261947	SOLENOID CARTRIDGE COMPLETE	8	
11		601888013	SEAL KIT	1	
12		296261948	O - RING	8	
13		296261949	SOLENOID ACTUATOR KIT	4	
14		296261950	BODY ASSEMBLY - CENTER SECTION	4	Inc One Of Ref No's 8 ,13 ,19 & Two Of Ref No 10
15		296261951	STUD KIT	1	
16		296261952	OUTLET COVER ASSEMBLY	1	Inc Ref No's 17 ,18
17		296261953	CENTER PLUG KIT	1	
18		296261954	SEAL KIT	1	
19		296261955	LOAD CHECK PLUG KIT	4	
20		296278014	SOLENOID PROPORTIONAL	1	
		283003001	FOUR SECTION VALVE - CRANE CONTROLS		Included All Ref. 1-20

Components-Valve-Crane Control Fig 12-1

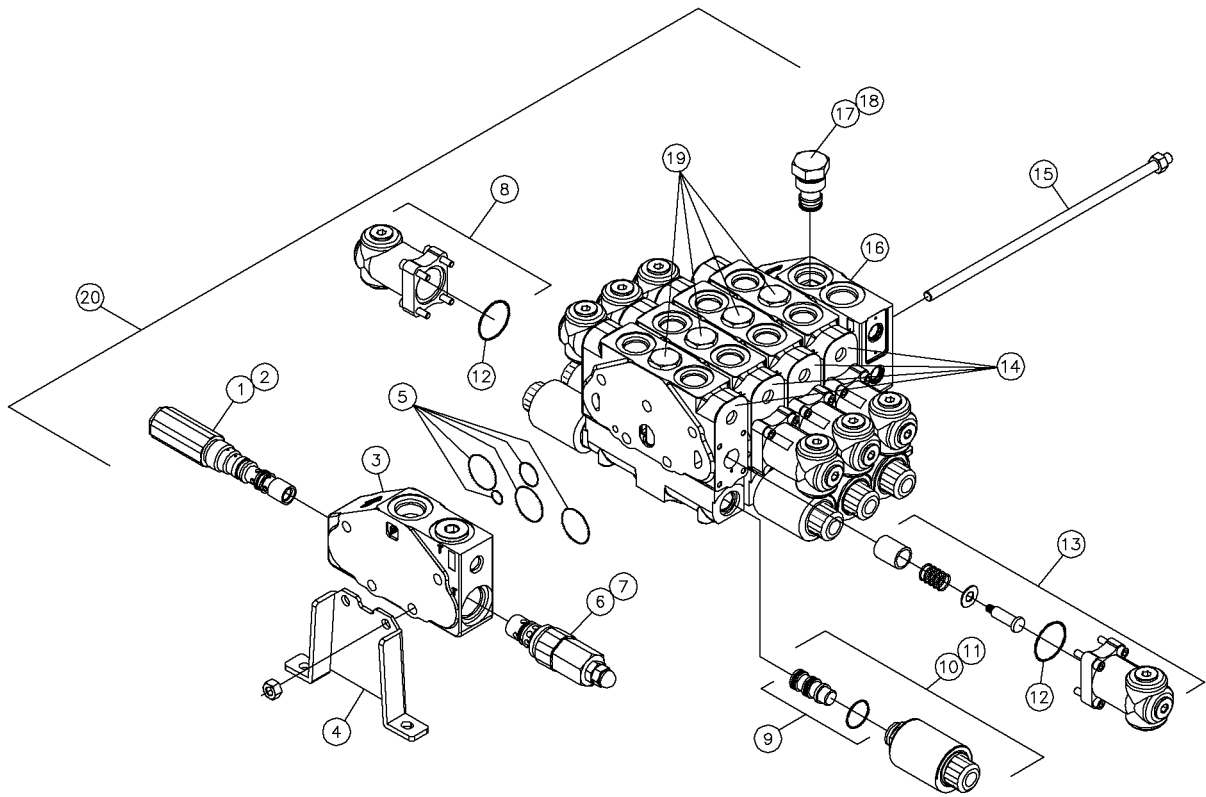

Components-Valve-Crane Control Fig 12-1

REF. NO.	*	PART NO.	DESCRIPTION	QTY.	REMARKS
1		296261938	VALVE - PRESSURE REDUCING	1	
2		296261939	SEAL KIT	1	
3		296261940	COVER - INLET ASSEMBLY	1	Inc One Of Ref No's 1 ,2 ,6 ,7
4		296261941	BRACKET KIT	1	Complete
5		296261942	SEAL KIT	5	
6		296261943	RELIEF CARTRIDGE	1	
7		296261944	SEAL KIT	1	
8		296261945	SOLENOID ACTUATOR KIT	4	
9		296261946	CARTRIDGE	8	
10		296261947	SOLENOID CARTRIDGE COMPLETE	8	
11		601888013	SEAL KIT	1	
12		296261948	O - RING	8	
13		296261949	SOLENOID ACTUATOR KIT	4	
14		296261950	BODY ASSEMBLY - CENTER SECTION	4	Inc One Of Ref No's 8 ,13 ,19 & Two Of Ref No 10
15		296261951	STUD KIT	1	
16		296261952	OUTLET COVER ASSEMBLY	1	Inc Ref No's 17 ,18
17		296261953	CENTER PLUG KIT	1	
18		296261954	SEAL KIT	1	
19		296261955	LOAD CHECK PLUG KIT	4	

Component-Hyd-Valve Relief Fig 12-2

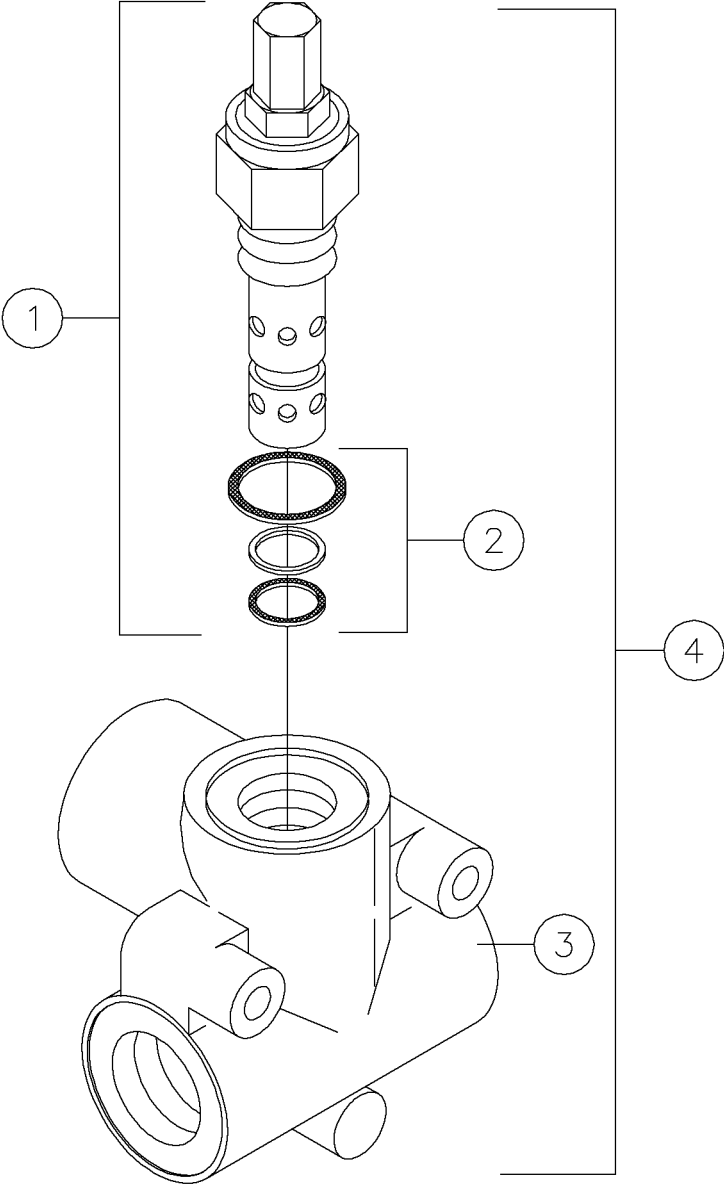

Component-Hyd-Valve Relief Fig 12-2

REF. NO.	*	PART NO.	DESCRIPTION	QTY.	REMARKS
1		228252003	CARTRIDGE -3000 PSI RELIEF	1	
2		213758017	SEAL KIT-RELIEF	1	
3		NSS	BODY	1	
4		224753001	VALVE-RELIEF RV SERIES	1	Inc All Items In Figure

Component-Hyd-Valve Diverter Fig 12-3

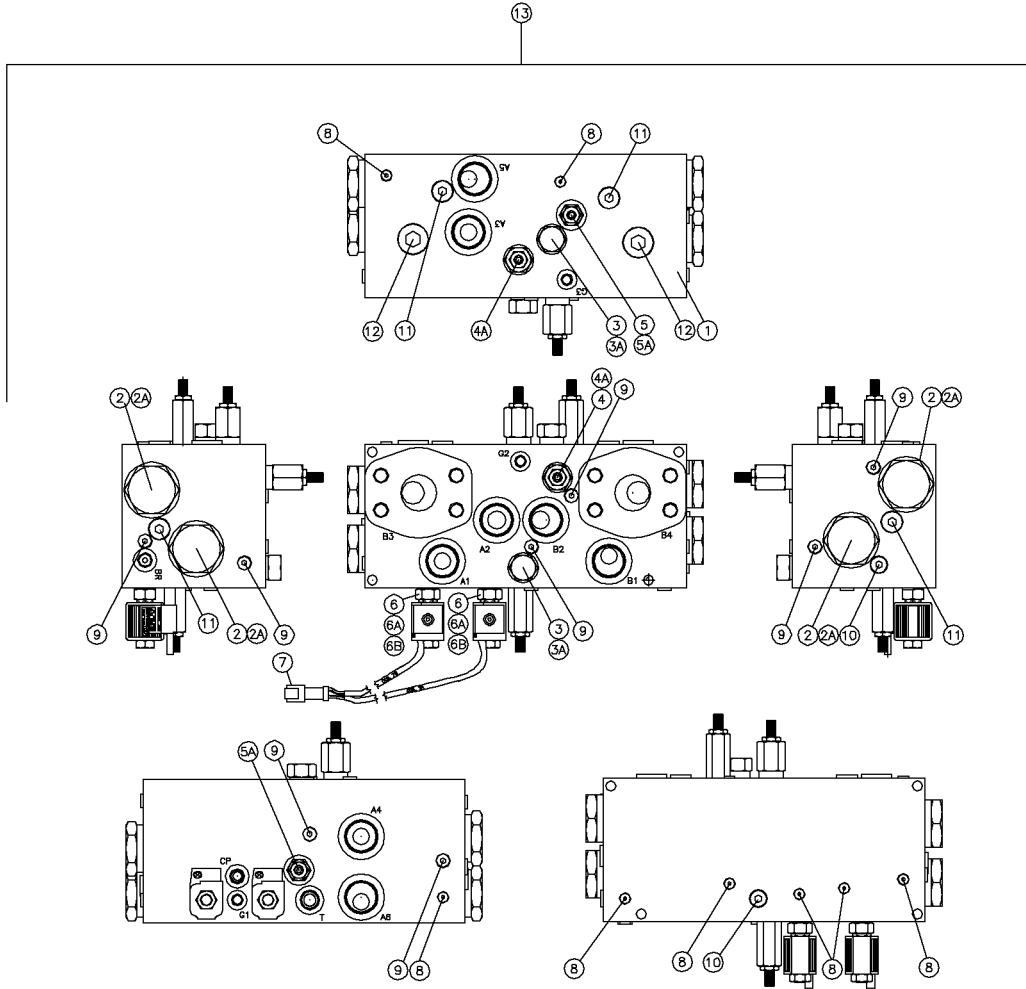

Component-Hyd-Valve Diverter Fig 12-3

REF. NO.	*	PART NO.	DESCRIPTION	QTY.	REMARKS
1		NSS	BLOCK	1	
2		296253466	PILOT OPERATED DIRECTIONAL VALVE	4	
2A		296253476	SEAL KIT	4	
3		296253467	SHUTTLE VALVE	2	
3A		277838005	REPAIR KIT - SHUTTLE VALVE	2	
4		296253468	FLOW REGULATOR	2	
4A		277838013	REPAIR KIT - RELIEF VALVE	2	
5		296253469	RELIEF VALVE	2	
5A		296253477	SEAL KIT	2	
6		296253470	2/3 SOLENOIL SPOOL VALVE	2	
6A		255075023	SEAL KIT	2	
6B		296263292	24V DC COIL	2	
7		296253471	4 PIN WIRE HARNESS	1	
8		296253472	#2 ZERO - LEAK HOLLOW HEX PLUG	8	
9		255268009	#4 ZERO-LEAK HOLLOW HEX PLUG	8	
10		296253473	#6 ZERO - LEAK HOLLOW HEX PLUG	2	
11		296253474	#8 ZERO - LEAK HOLLOW HEX PLUG	4	
12		296253475	#12 ZERO - LEAK HOLLOW HEX PLUG	2	
13		277900001	VALVE - SELECTOR #9003178A	1	Inc All Item In This Figure

Component-Hyd-Valve Directional Fig 12-4

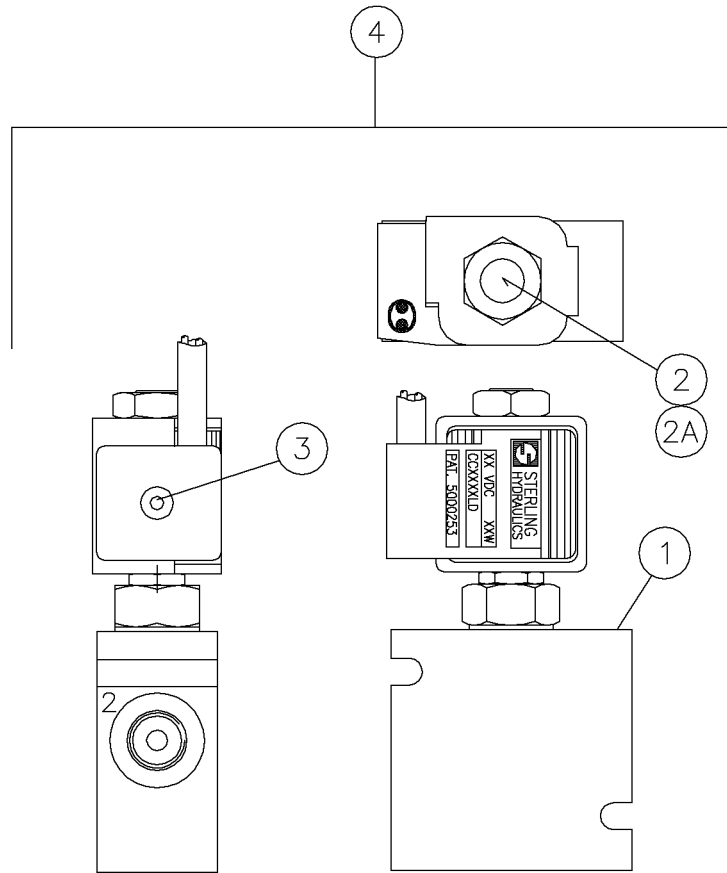

Component-Hyd-Valve Directional Fig 12-4

REF. NO.	*	PART NO.	DESCRIPTION	QTY.	REMARKS
1		296253498	LINE BODY	1	
2		224476005	CARTRIDGE-VALVE	1	
2A		255075023	SEAL KIT	1	
3		296253500	24V COIL (DEUTSCH WITH DIODE)	1	
4		277905001	VALVE -2P- 3W 24V #9S003180A	1	In. All Items In Figure

Component-Hyd-Valve High Speed Fig 12-5

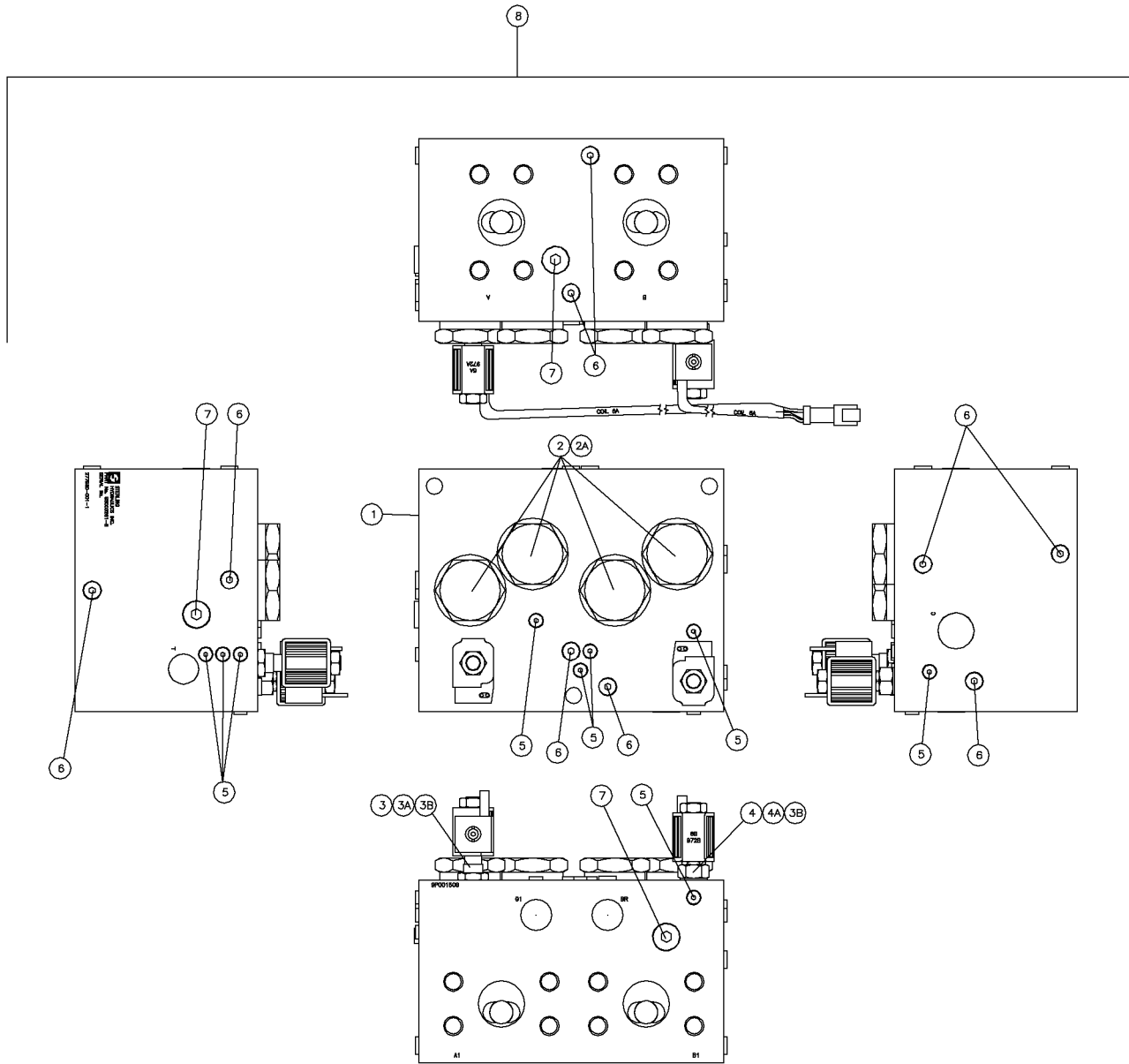

Component-Hyd-Valve High Speed Fig 12-5

REF. NO.	*	PART NO.	DESCRIPTION	QTY.	REMARKS
1		NSS	BLOCK	1	
2		296263263	PILOT OPERATED DIRECTIONAL VALVE	4	
2A		296263264	SEAL KIT	4	
3		296263265	SOLENOIL VALVE	1	
3A		255077007	SEAL KIT	1	
3B		296263292	24V DC COIL	2	
4		255075021	2 WAY/3 WAY SOLENOID VALVE	1	
4A		255075023	SEAL KIT	1	
5		296253472	#2 ZERO - LEAK HOLLOW HEX PLUG	9	
6		255268009	#4 ZERO-LEAK HOLLOW HEX PLUG	9	
7		296253474	#8 ZERO - LEAK HOLLOW HEX PLUG	3	
8		277980001	VALVE - HIGH SPEED	1	Inc All Items In Figure

Component-Hyd-Valve 3 Speed Flush Fig 12-6

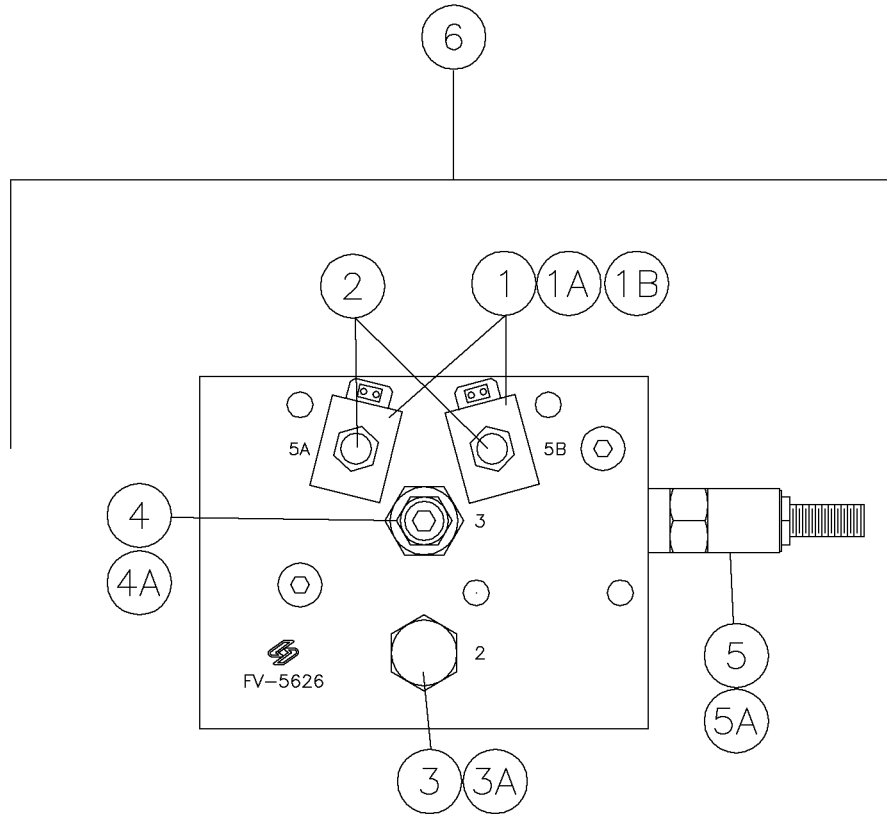

Component-Hyd-Valve 3 Speed Flush Fig 12-6

REF. NO.	*	PART NO.	DESCRIPTION	QTY.	REMARKS
1		296263265	SOLENOIL VALVE	2	
1A		296263266	COIL	2	
1B		296263291	SEAL KIT	2	
2		296263293	NUT	2	
3		296263269	SHUTTLE VALVE	1	
3A		277838005	SEAL KIT	1	
4		296263268	FLOW CONTROL/PRESSURE COMP.	1	
4A		296263294	SEAL KIT	1	
5		296263267	RELIEF VALVE	1	
5A		251117013	SEAL KIT	1	
6		277902001	VALVE - 3 - SPD FLUSH FV-5626-AGGJK	1	Inc All Items In Figure

Component-Hyd-Valve Crane Base Fig 12-7

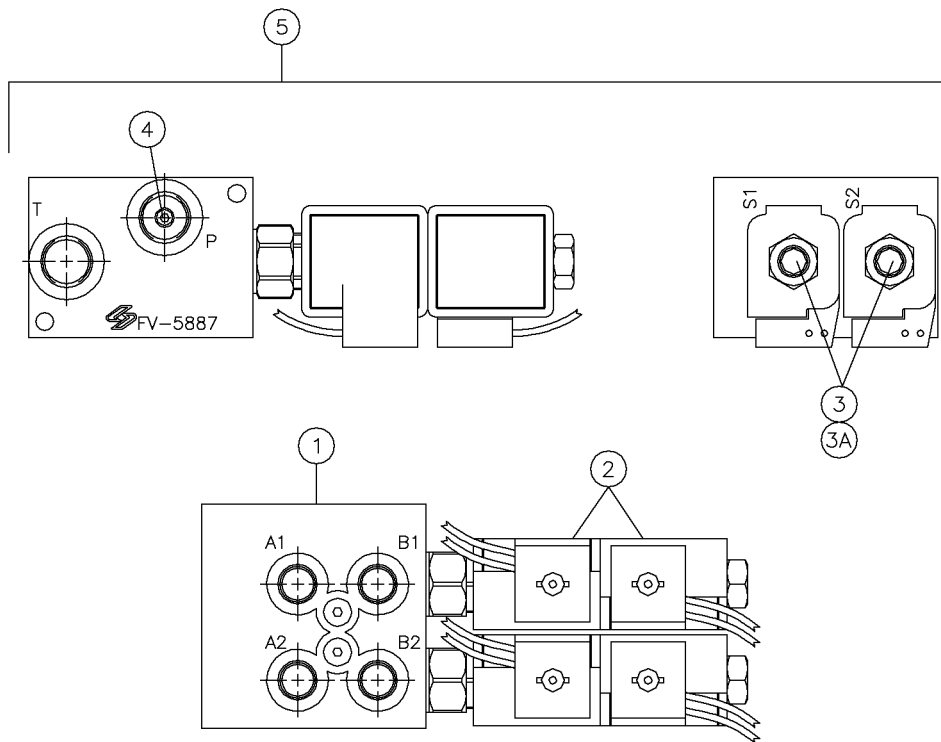

Component-Hyd-Valve Crane Base Fig 12-7

REF. NO.	*	PART NO.	DESCRIPTION	QTY.	REMARKS
1		NSS	BODY	1	
2		296261979	COIL	4	
3		296261980	CARTRIDGE	2	
3A		255075013	SEAL KIT	2	
4		296261981	PLUG	1	
5		288467001	VALVE - CRANE BASE	1	Inc All Items In Figure

Component-Hyd-Valve Heater/Cooler Manifold Fig 12-8

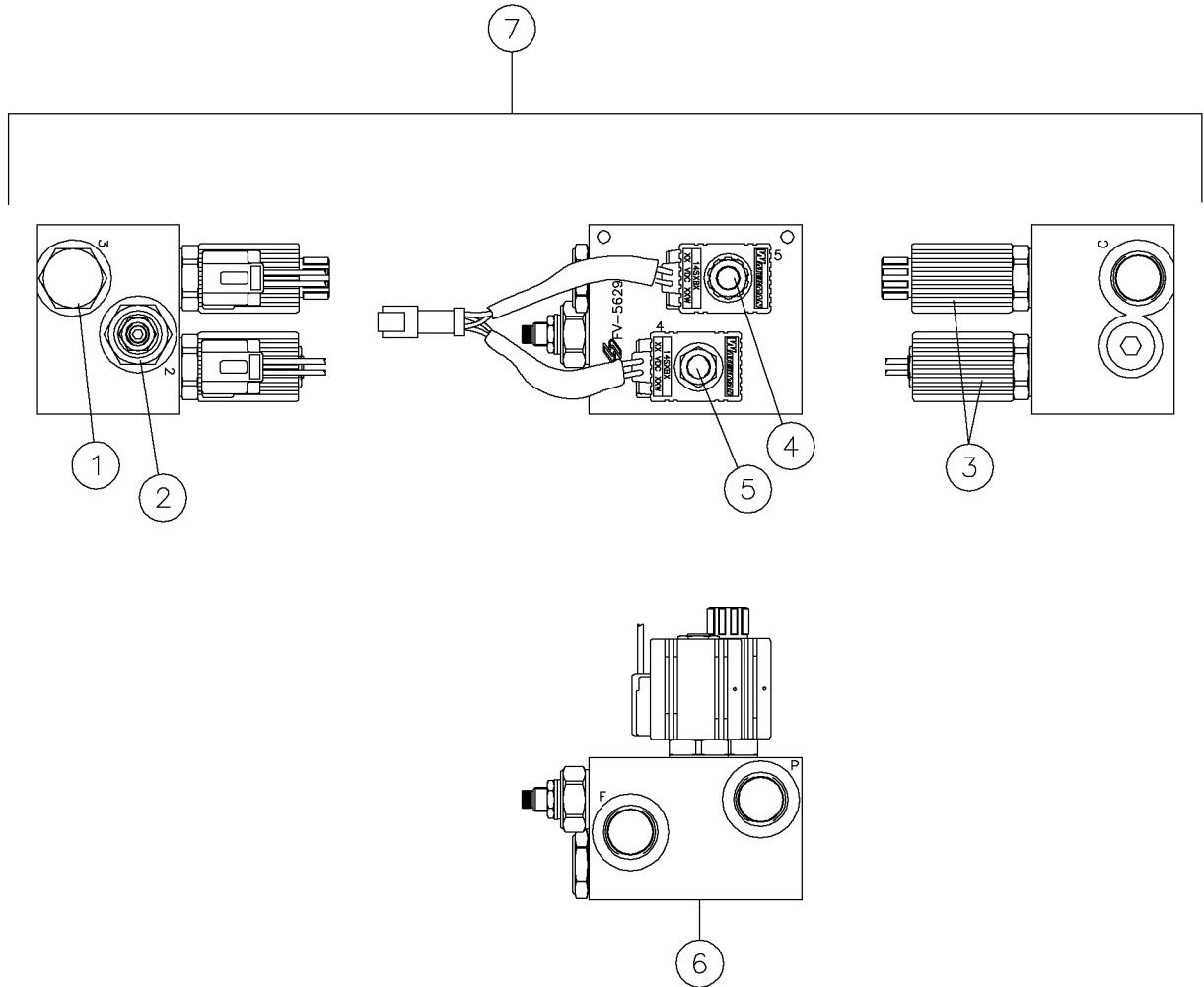

Component-Hyd-Valve Heater/Cooler Manifold Fig 12-8

REF. NO.	*	PART NO.	DESCRIPTION	QTY.	REMARKS
1		296261990	CHECK VALVE	1	
2		296261989	RELIEF VALVE	1	
3		296261993	COIL	2	
4		296261991	SOLENOID VALVE	1	
5		296261992	SOLENOID VALVE	1	
6		NSS	BODY	1	
7		277903001	VALVE - HEATER - COOLER - FILTER - MANIFOLD	1	Inc All Items In Figure

Component-Hyd-Valve Bleeder Fig 12-9

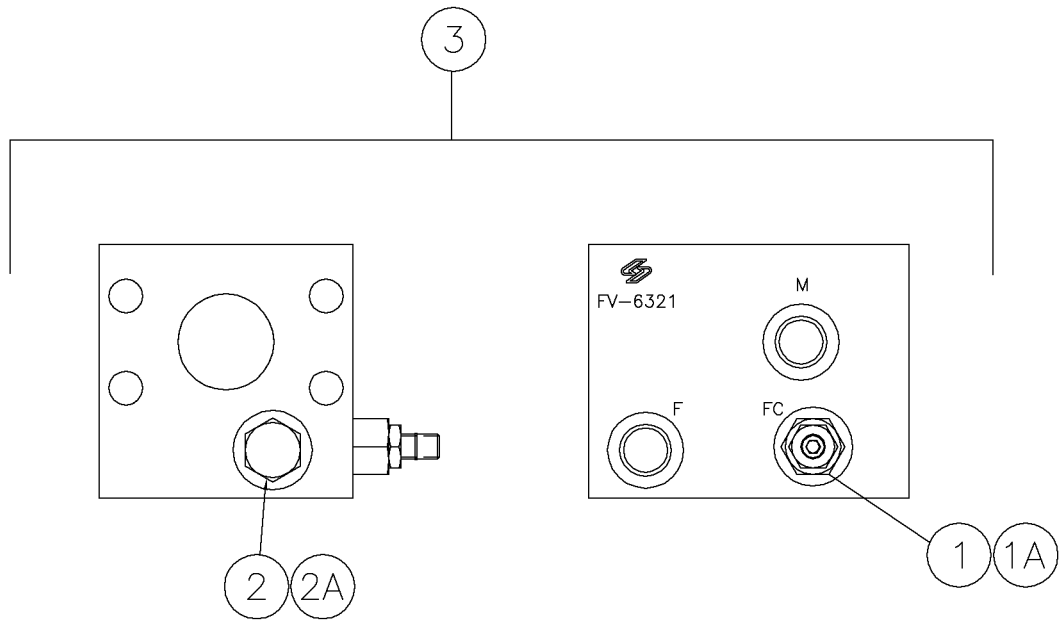

Component-Hyd-Valve Bleeder Fig 12-9

REF. NO.	*	PART NO.	DESCRIPTION	QTY.	REMARKS
1		296263327	STERLING FLOW CONTROL	1	
1A		296253477	SEAL KIT	1	
2		296263328	CHECK VALVE	1	
2A		296263329	SEAL KIT	1	
3		296261576	VALVE - T/P BLEEDER	1	Inc All Items In Figure

Component-Hyd-Pump Fan Fig 12-10

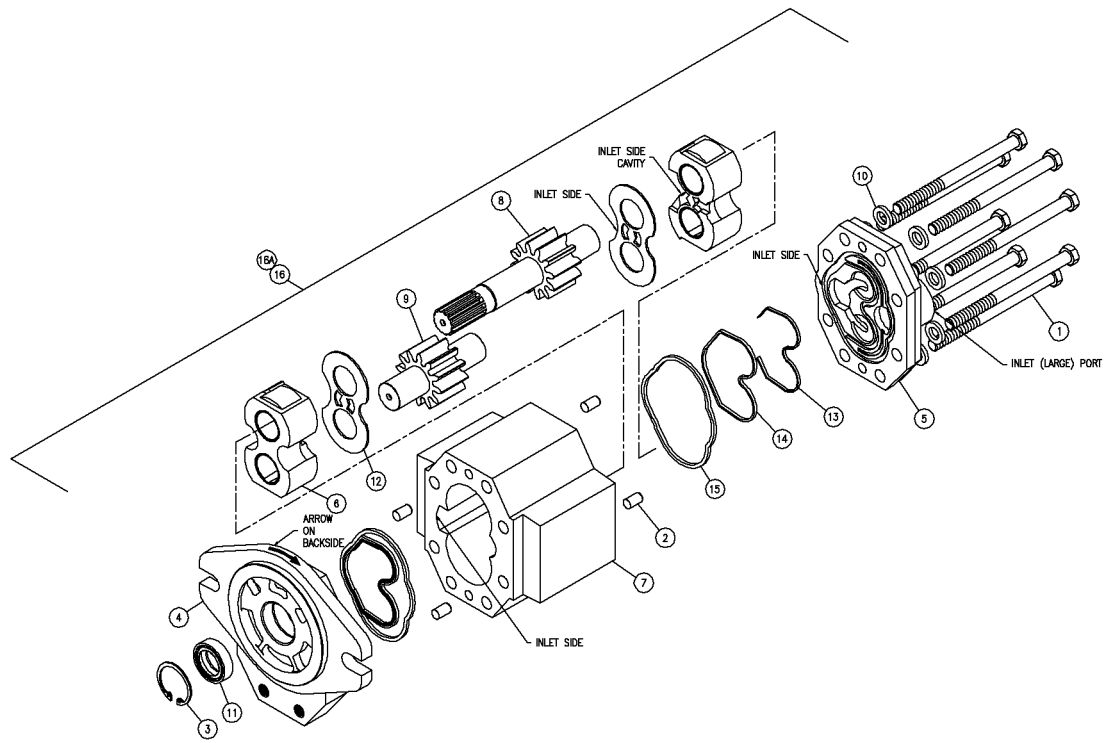

Component-Hyd-Pump Fan Fig 12-10

REF. NO.	*	PART NO.	DESCRIPTION	QTY.	REMARKS
1		296261771	BOLT	8	
2		99664005	PIN-DOWEL	4	
3		220509005	SNAP RING	1	
4		220509007	FRONT PLATE	1	
5		296261770	BACK PLATE	1	
6		220509011	BEARING CASE ASSEMBLY	2	
7		296261772	BODY	1	
8		296261773	SPLINE DRIVE	1	
9		214233029	FRONT IDLER	1	
10		296261774	WASHER	8	
11		220509027	SHAFT SEAL	1	
12		220509019	SIDE PLATE	2	
13		220509025	BACKUP STRIP	2	
14		220509023	SP-25 INNER SEAL	2	
15		220509021	SP-25 OUTER SEAL	2	
16		288985001	PUMP - GEAR, 2.318 CIR CW	1	Inc All Items In Figure
16A		296261775	SEAL KIT	1	Inc One Of Ref No's 11, 13-15

Component-Hyd-Pump Ground Drive/Thrust Fig 12-11

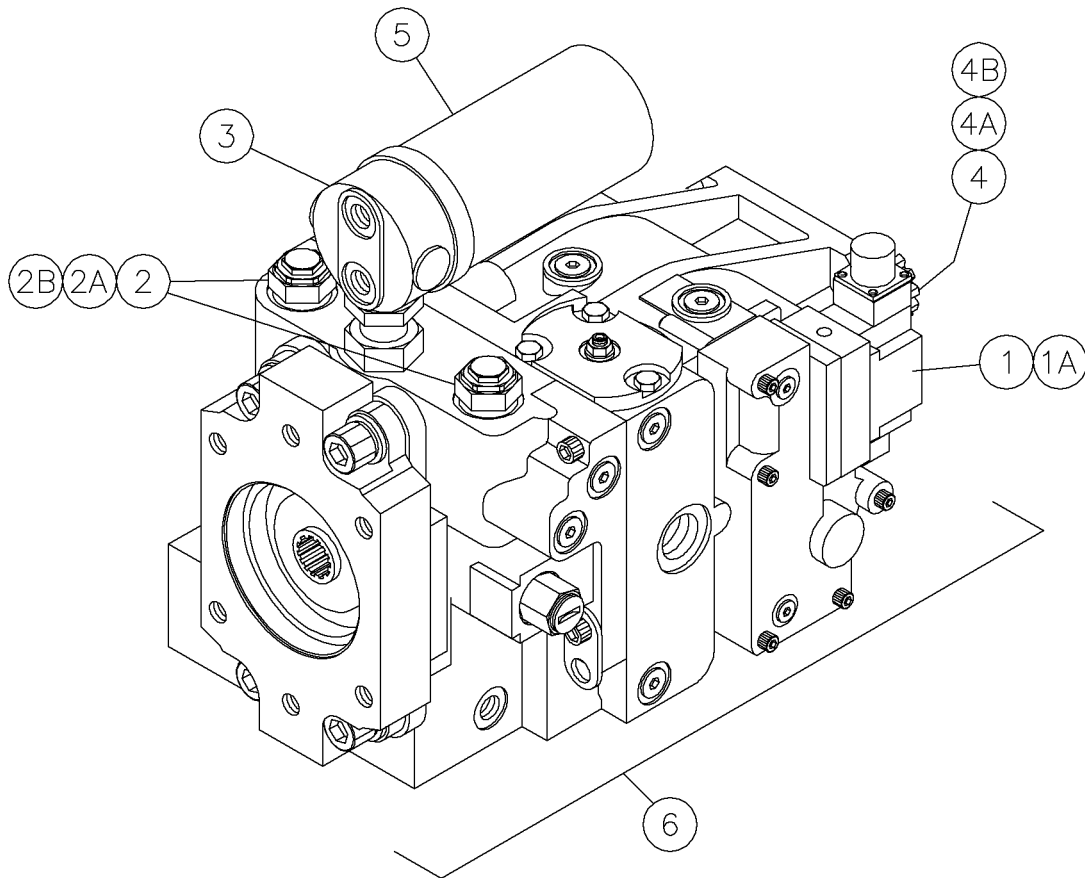

Component-Hyd-Pump Ground Drive/Thrust Fig 12-11

REF. NO.	*	PART NO.	DESCRIPTION	QTY.	REMARKS
1		224411003	EDC KIT W/MS CONNECTOR	1	
1A		224411005	GASKET-CONTROL	1	
2		85642007	VALVE-MULTI-FUNCTION	2	
2A		85642009	O-RING	2	
2B		85642011	O-RING	2	
3		85642051	FILTRATION-INTEGRAL SHT FILTER	1	
4		98688009	LIP SEAL	1	
4A		98688011	SEAL-CARRIER	1	
4B		98688013	O-RING	1	
5		81902001	FILTER-OIL	1	
6		296261912	PUMP - HYD 90 SERIES 75 CC (FRONT)	2	Inc All Items In Figure

Component-Hyd-Pump Rotation Fig 12-12

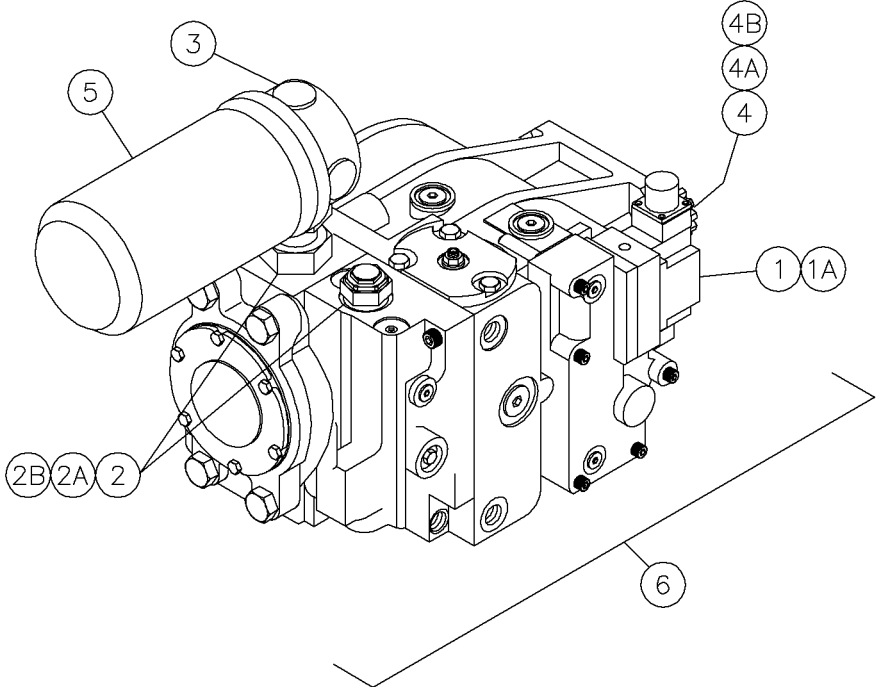

Component-Hyd-Pump Rotation Fig 12-12

REF. NO.	*	PART NO.	DESCRIPTION	QTY.	REMARKS
1		224411003	EDC KIT W/MS CONNECTOR	1	
1A		224411005	GASKET-CONTROL	1	
2		85642007	VALVE-MULTI-FUNCTION	2	
2A		85642009	O-RING	2	
2B		85642011	O-RING	2	
3		85642051	FILTRATION-INTEGRAL SHT FILTER	1	
4		98688009	LIP SEAL	1	
4A		98688011	SEAL-CARRIER	1	
4B		98688013	O-RING	1	
5		81902001	FILTER-OIL	1	
6		296261915	PUMP - HYD 90 SERIES 75 CC (REAR)	2	Inc All Items In Figure

Component-Hyd-Cylinder Crane Base Fig 12-13

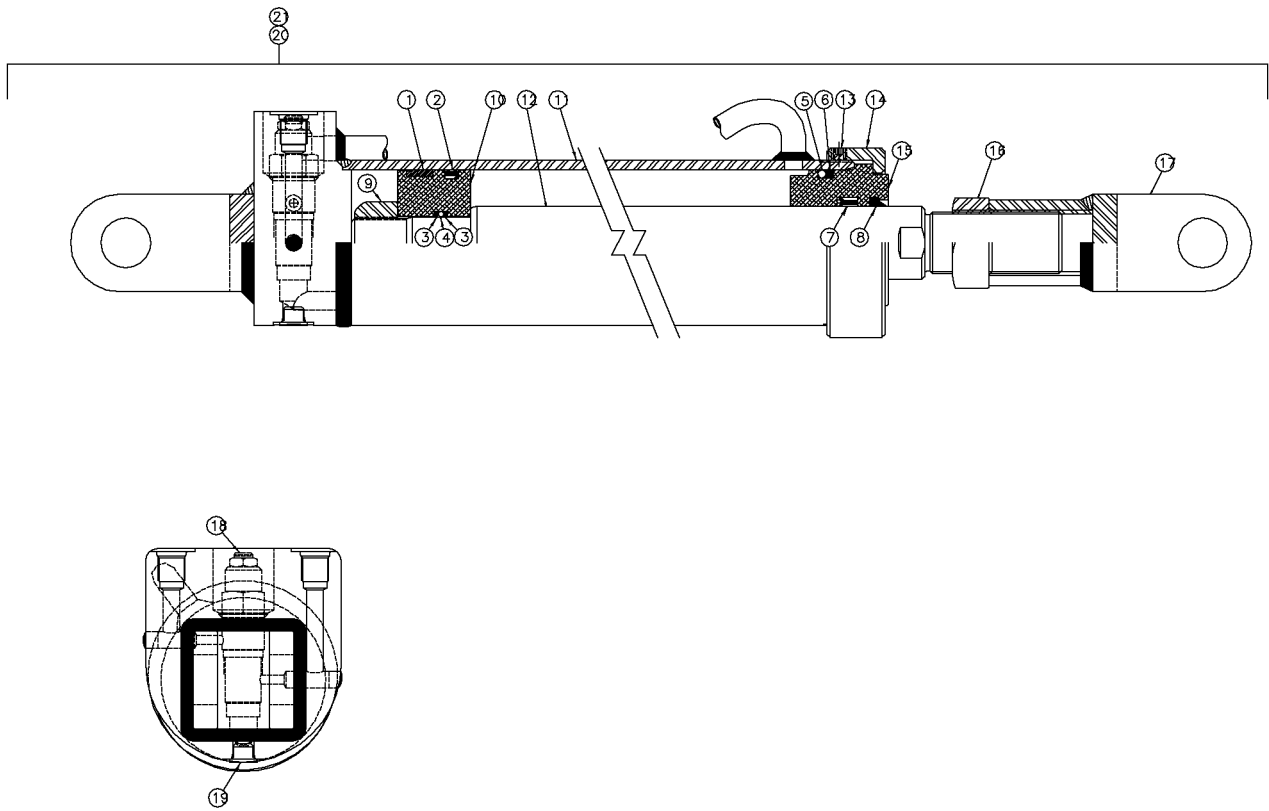

Component-Hyd-Cylinder Crane Base Fig 12-13

REF. NO.	*	PART NO.	DESCRIPTION	QTY.	REMARKS
1		232860007	WEAR RING	1	
2		608504001	PSP SEAL	1	
3		208331001	RING-BACK UP	2	
4		208332001	O-RING	1	
5		NSS		1	
6		NSS		1	
7		NSS		1	
8		200808001	WIPER 52-1500	1	
9		296251758	LOCKNUT	1	
10		208340001	PISTON	1	
11		296261959	BARREL ASSEMBLY	1	
12		296261960	ROD	1	
13		296251757	SCREW-CUP POINT SET	1	
14		218496013	THREADED CAP	1	
15		207403005	CAP HEAD-THREAD	1	
16		296261957	NUT - JAM	1	
17		296261958	CLEVIS ASSEMBLY	1	
18		229414007	VALVE CARTRIDGE - COUNTER BALANCE	1	
19		296251008	STEEL PLUG	1	
20		296258260	CYLINDER - 3" X 24" ADJUSTABLE CLEVIS	2	Inc All Items In Figure
21		296261956	SEAL KIT	1	Inc Ref No's 1-8

Component-Hyd-Cylinder Crane Base Lock Fig 12-14

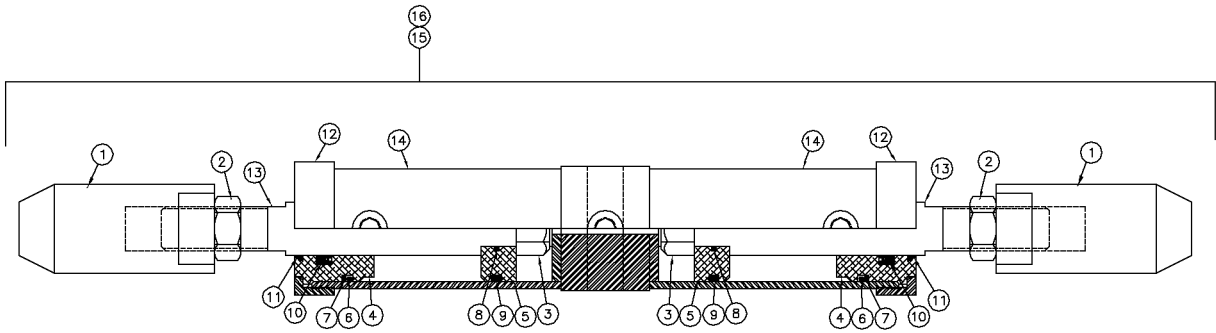

Component-Hyd-Cylinder Crane Base Lock Fig 12-14

REF. NO.	*	PART NO.	DESCRIPTION	QTY.	REMARKS
1		296261970	CLEVIS	2	
2		296261971	NUT	2	
3		236113003	NUT	2	
4		296261972	HEAD	2	
5		278306003	PISTON - CYLINDER	2	
6		NSS		2	
7		NSS		2	
8		NSS		2	
9		NSS		2	
10		NSS		2	
11		NSS		2	
12		296261973	COLLAR	2	
13		296261974	SHAFT	2	
14		296261975	BAREL	1	
15		292850001	CYLINDER - 3" X 3" - DOUBLE ROD	1	Inc All Items In Figure
16		296261976	REPAIR KIT	1	Inc Two Of Ref No's 6-11

Component-Hyd-Valve Catwalk Multifunction Fig 12-15

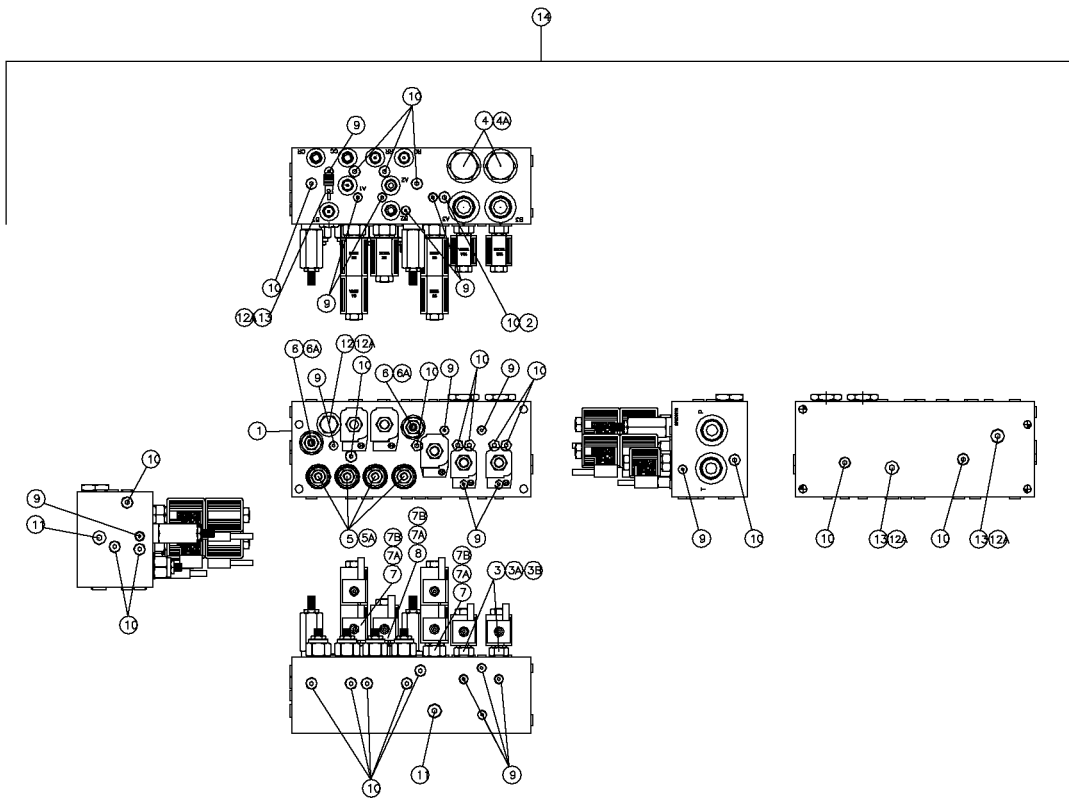

Component-Hyd-Valve Catwalk Multifunction Fig 12-15

REF. NO.	*	PART NO.	DESCRIPTION	QTY.	REMARKS
1		NSS	BLOCK	1	
2		258102015	ORIFICE PLUG (M8 X 1.25 W/2.00 MM)	1	
3		296253470	2/3 SOLENOIL SPOOL VALVE	2	
3A		296263258	SEAL KIT	2	
3B		296263292	24V DC COIL	2	
4		296263252	PILOT OPERATED DIRECTIONAL VALVE	2	
4A		125083021	SEAL KIT	2	
5		260787001	VALVE-LOAD CONTROL (TEMP FIX ONLY)	4	
5A		296263259	SEAL KIT	4	
6		296263253	SEQUENCE VALVE	2	
6A		255268013	SEAL KIT	2	
7		296263254	3/4 WAY SOLENOID SPOOL VALVE	2	
7A		296263260	SEAL KIT	3	
7B		296263290	24V DC COIL WITH LEADWIRE	4	
8		296263255	2/4 WAY SOLENOID SPOOL VALVE	1	
9		296253472	#2 ZERO - LEAK HOLLOW HEX PLUG	16	
10		255268009	#4 ZERO-LEAK HOLLOW HEX PLUG	22	
11		296253473	#6 ZERO - LEAK HOLLOW HEX PLUG	4	
12		296263256	CHECK VALVE	1	
12A		296263261	SEAL KIT	2	
13		296263257	PILOT PISTON	1	
14		277901001	VALVE - CATWALK #9S003176A	1	Inc All Items In Figure

Component-Hyd-Cylinder Fig 12-16

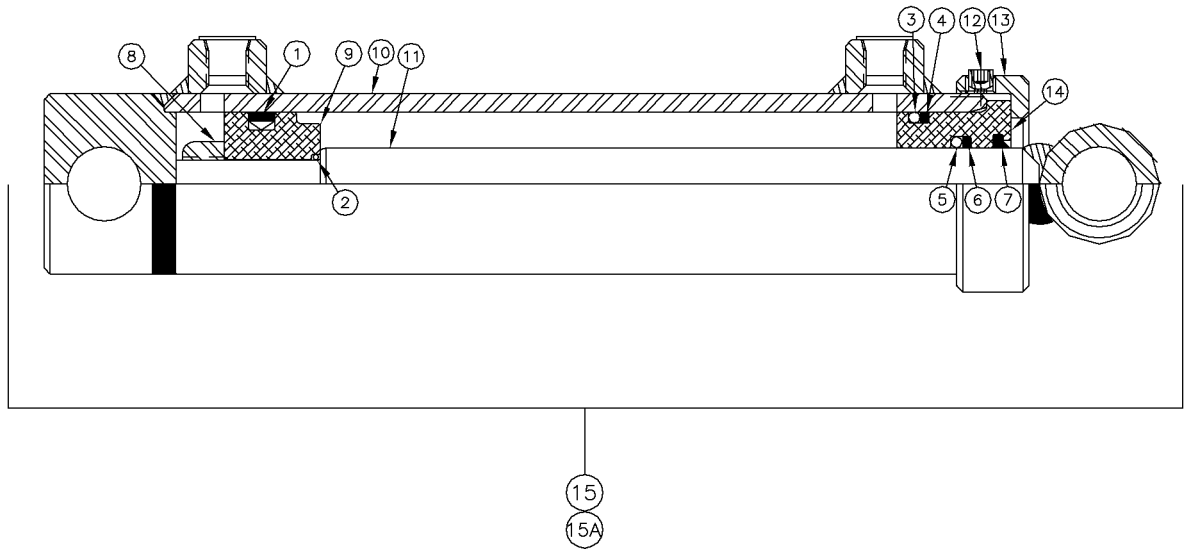

Component-Hyd-Cylinder Fig 12-16

REF. NO.	*	PART NO.	DESCRIPTION	QTY.	REMARKS
1		202721001	UNI-RING	1	
2		223998003	O-RING	1	
3		202727001	O-RING	1	
4		202726001	WASHER-BACK-UP	1	
5		223998005	O-RING	1	
6		223998007	BACK-UP RING	1	
7		202724001	WIPER-ROD	1	
8		202722001	LOCKNUT	1	
9		202720001	PISTON	1	
10		223998009	BARREL ASSEMBLY	1	
11		223998011	ROD ASSEMBLY	1	
12		223998013	SET SCREW	1	
13		223998015	THREAD CAP	1	
14		223998017	THREAD CAP HEAD	1	
15		223998001	CYLINDER- 1 1/2 X 6	1	Inc Ref No's 1-14
15A		223998019	SEAL KIT	1	Inc Ref No's 1-7

Component-Hyd-Cylinder Fig 12-17

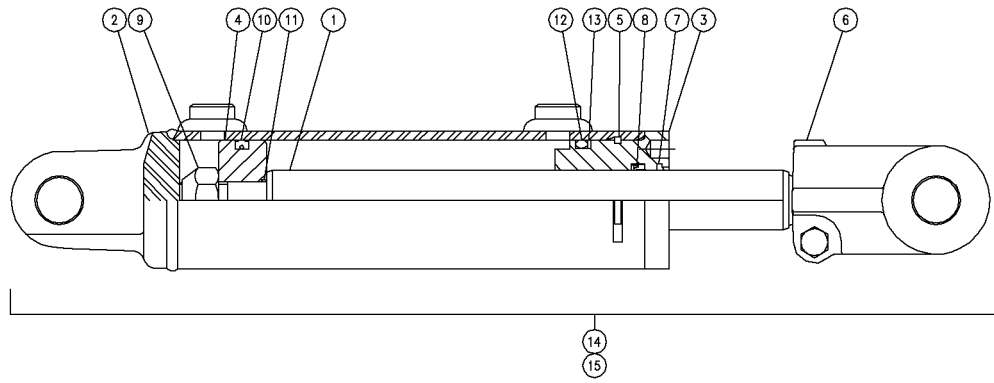

Component-Hyd-Cylinder Fig 12-17

REF. NO.	*	PART NO.	DESCRIPTION	QTY.	REMARKS
1		218444003	PISTON ROD	1	
2		NSS	BUTT & TUBE ASSEMBLY	1	
3		218444009	GLAND	1	
4		218444007	PISTON	1	
5		296261985	SQ. RET. RING	1	
6		100997023	CLEVIS ASS'Y	1	
7		296261987	WIPER	1	
8		296261986	U - CUP	1	
9		296261982	LOCKNUT	1	
10		125419021	BU-WASHER	1	
11		296261983	O - RING	1	
12		14360011	O-RING	1	
13		296261984	BU - WASHER	1	
14		288468001	CYLINDER - 2.5" X 8" - 1 1/4" ROD	1	Inc All Items In Figure
15		296261988	PACKING KIT	1	Inc One Of Ref No's 5 ,7 ,8 & 10-13

Component-Hyd-Cylinder Rack Pivot Fig 12-18

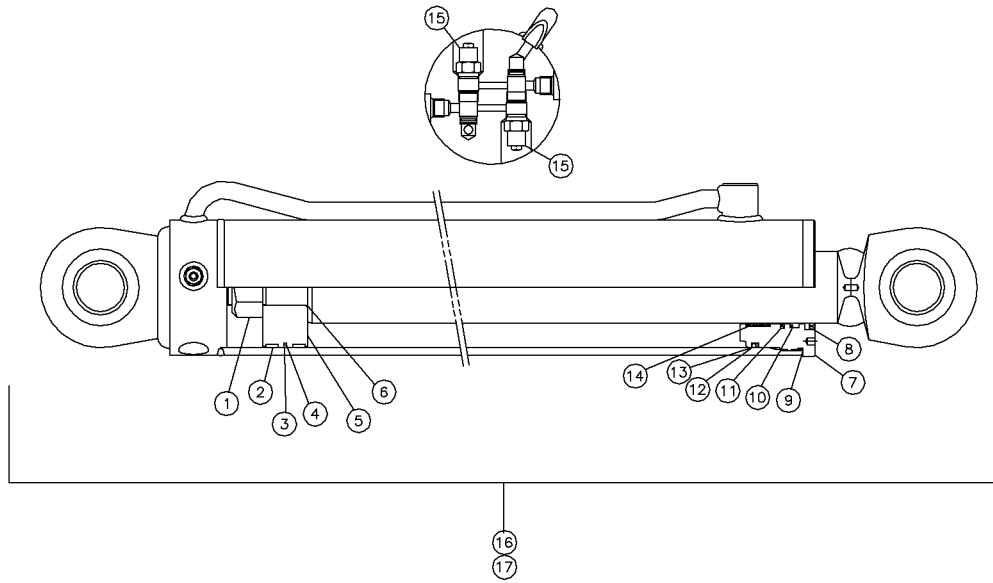

Component-Hyd-Cylinder Rack Pivot Fig 12-18

REF. NO.	*	PART NO.	DESCRIPTION	QTY.	REMARKS
1		296263404	NUT	1	
2		296263393	WEAR RING	2	
3		296263394	TFE SEAL	1	
4		296263395	EXPANDER	1	
5		296263407	PISTON	1	
6		296263396	O-RING	1	
7		296263406	HEAD GLAND	1	
8		296263400	WIPER	1	
9		296263403	O-RING	1	
10		296263399	U-CUP	1	
11		296263401	BUFFER SEAL	1	
12		296263397	O-RING	1	
13		296263398	BACKUP	1	
14		296263402	WEAR RING	1	
15		296263405	VALVE	2	
16		296263408	SEAL KIT	1	
17		239373001	CYLINDER - 5" X 25"	1	Inc All Items In Figure

Component-Hyd-Cylinder Lower Boom Fig 12-19

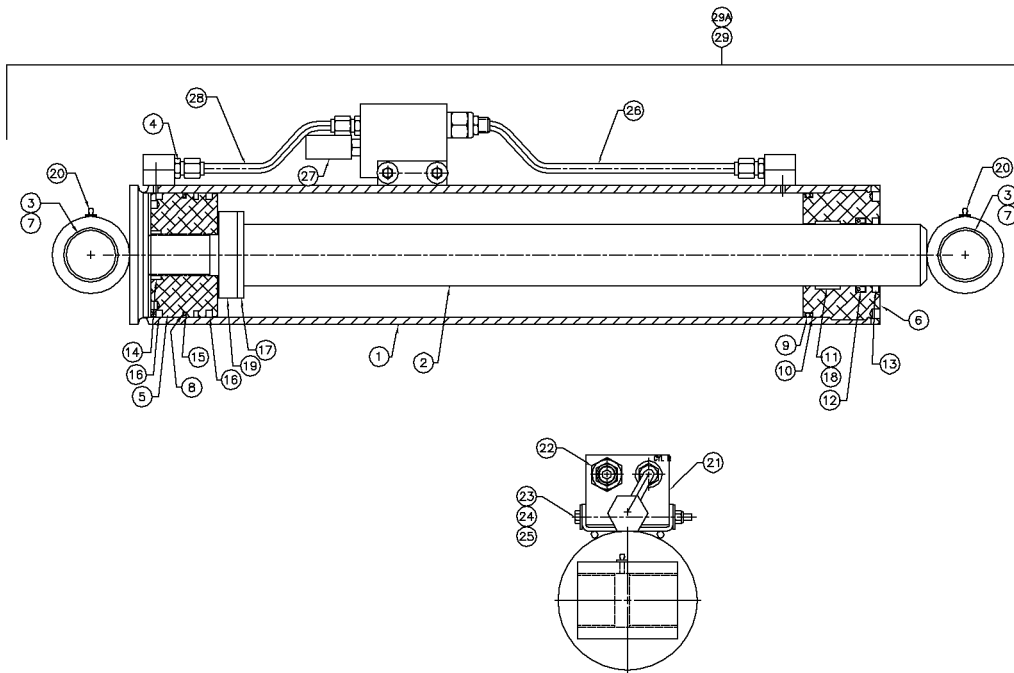

Component-Hyd-Cylinder Lower Boom Fig 12-19

REF. NO.	*	PART NO.	DESCRIPTION	QTY.	REMARKS
1		296261855	CASE ASSEMBLY	1	
2		296261856	ROD ASSEMBLY	1	
3		296261755	BUSHING - STL 2.00 PIN X 1.5 LG	5	
4		296261858	ADAPTER	4	
5		296261859	PISTON	1	
6		296261860	HEAD	1	
7		296261879	BUSHING	1	
8		296261862	O - RING	1	
9		296261863	O - RING	1	
10		296261864	BACKUP RING	1	
11		296261865	WEAR RING	1	
12		296261866	U - CUP	1	
13		296261867	ROD WIPER	1	
14		296261868	LOCK RING	1	
15		296261869	PISTON SEAL	1	
16		296261870	PISTON RING	2	
17		296261871	WAFER LOCK	1	
18		296261872	WEAR RING - ROD	1	
19		296261873	STOP TUBE	1	
20		598001	ZERK-1/4" NF ST GREASE	3	
21		296261874	VALVE	1	Inc Ref No's 22 ,27
22		296261875	VALVE	1	
23		351040	BOLT-5/16-18X4" GRADE#5 HEX	2	
24		3215005	WASHER GRESEN 1214-001	4	
25		104212001	NUT-5/16-18 NYLON INSERT LOCK	2	
26		296261876	TUBE ASSEMBLY	1	
27		296261877	PRESSURE SWITCH	1	
28		296261878	TUBE ASSEMBLY	1	
29		296261759	CYLINDER - 6.0/3.0	1	Inc All Items In Figure
29A		296261861	SEAL KIT	1	Inc Ref No's 9-17

Component-Hyd-Cylinder Extension Boom Fig 12-20

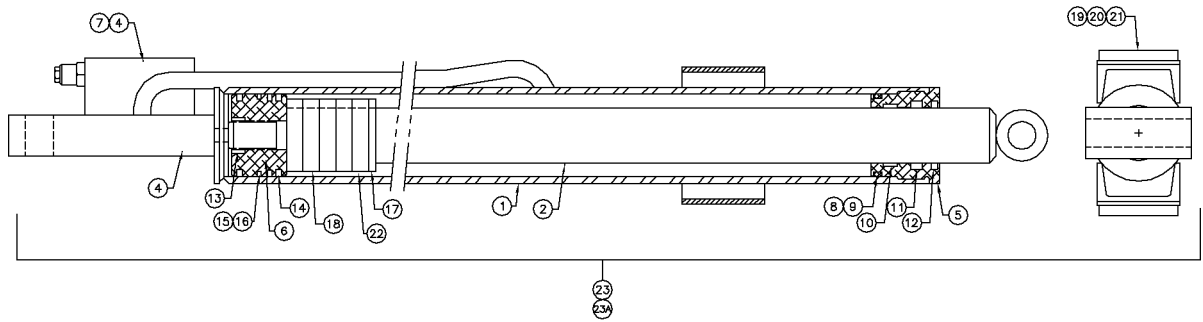

Component-Hyd-Cylinder Extension Boom Fig 12-20

REF. NO.	*	PART NO.	DESCRIPTION	QTY.	REMARKS
1		296261831	CASE ASSEMBLY	1	
2		296261832	ROD ASSEMBLY	1	
3		296261833	PIPE PLUG	2	Part Of Ref No 1 (Not Shown)
4		296261834	VALVE	1	
5		296261835	HEAD	1	
6		296261836	PISTON	1	
7		296261853	CAP SCREW	6	
8		296261838	O - RING	1	
9		296261839	BACKUP RING	1	
10		296261840	WEAR RING	1	
11		296261841	U-CLIP	1	
12		296261842	ROD WIPER	1	
13		296261843	LOCK RING	1	
14		296261844	PISTON RING	2	
15		296261845	PISTON SEAL	1	
16		296261846	O-RING	1	
17		296261847	WAFER LOCK	1	
18		296261848	STOP TUBE	9	
19		296261849	SPACER - WEAR PAD	2	
20		296261850	WEAR PAD	2	
21		296261851	CAP SCREW	8	
22		296261852	STOP TUBE	1	
23		296261760	EXTENSION CYLINDER	1	Inc All Items In Figure
23A		296261837	SEAL KIT	1	

Component-Track Roller Fig 12-21

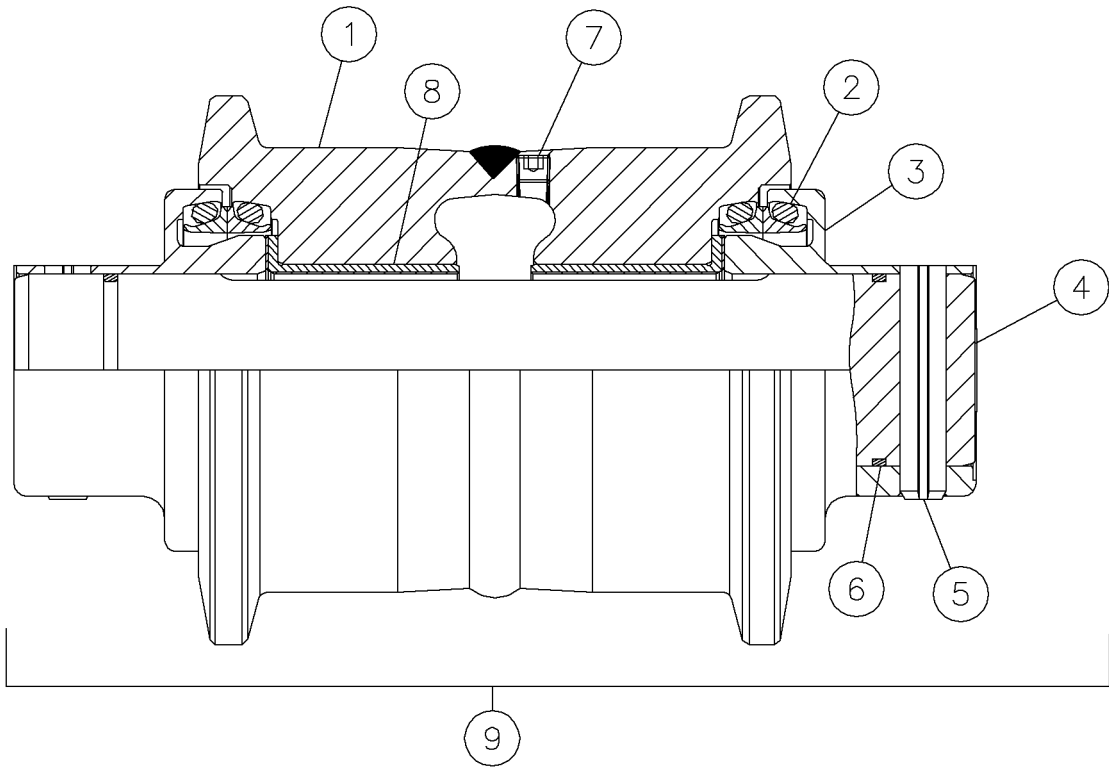

Component-Track Roller Fig 12-21

REF. NO.	*	PART NO.	DESCRIPTION	QTY.	REMARKS
1		901600003	ROLLER ASSEMBLY	1	
2		904600005	SEAL GROUP	2	
3		901600007	COLLAR	2	
4		901600009	SHAFT	1	
5		901600011	PIN	2	
6		901600013	SEAL	2	
7		901600015	PLUG	1	
8		901600017	BEARING	2	
9		901600001	ROLLER-TRACK D4 7T6395	1	Inc All Items In Figure

Component-Track Drive Gearbox Fig 12-22

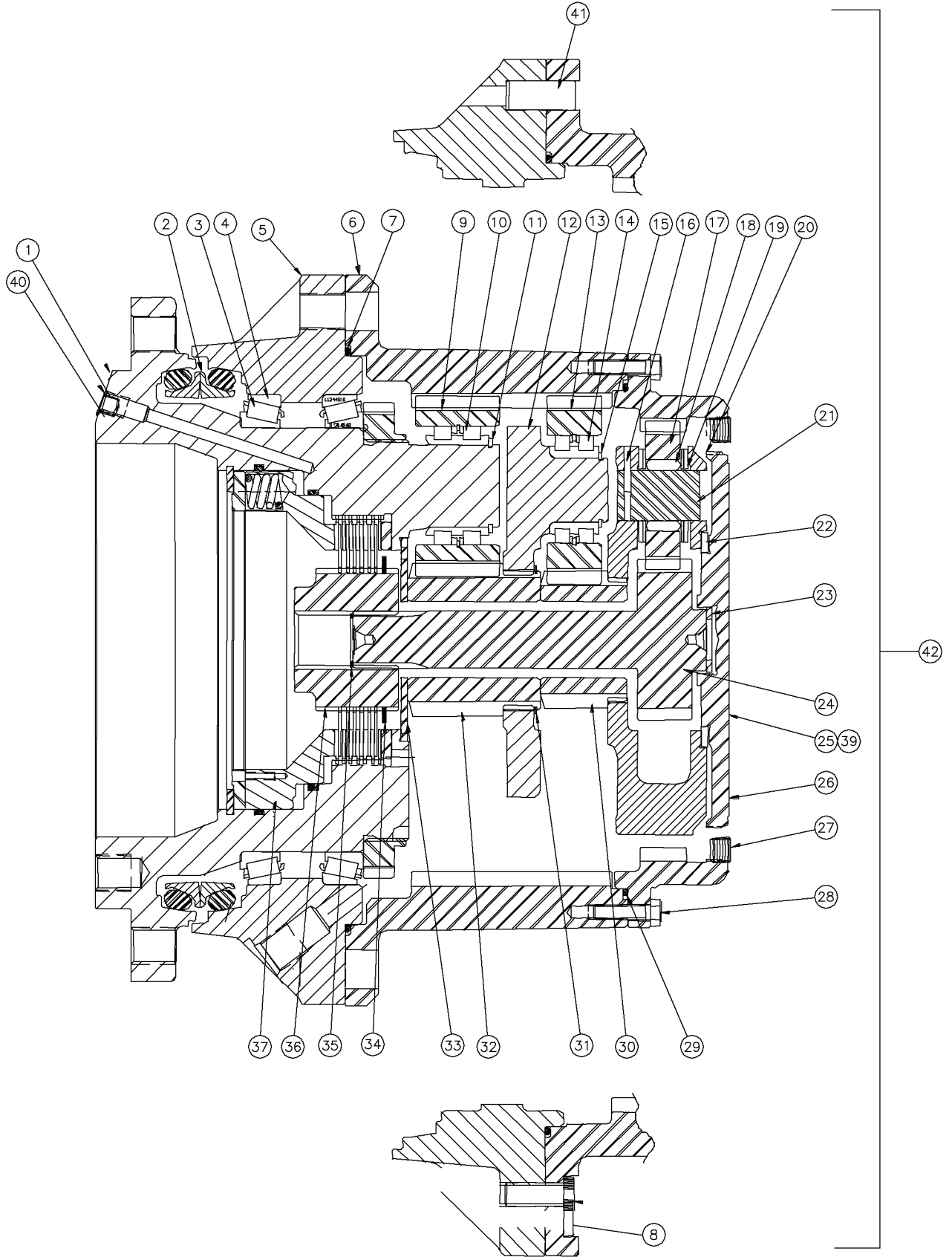

Component-Track Drive Gearbox Fig 12-22

REF. NO.	*	PART NO.	DESCRIPTION	QTY.	REMARKS
1		605220001	SPINDLE	1	
2		605221001	SEAL FACE	1	
3		605222001	BEARING-TAPERED CONE	2	
4		605223001	BEARING-TAPERED CUP	2	
5		605224001	HOUSING	1	
6		605225001	GEAR-RING	1	
7		605226001	O-RING	1	
8		114280021	BOLT-SKT.-UNC	2	
9		605227001	SET	1	
10		605228001	BEARING-CYLINDER ROLLER	5	
11		605229001	RET.RING-EXT	5	
12		605230001	CARRIER (2ND STG.)	1	
13		114280031	GEAR-PLANET	3	
14		114280033	BEARING-CYL. ROLLER	3	
15		114280035	RET.RING-EXT.	3	
16		114280037	PIN-ROLL	3	
17		605231001	GEAR-PLANET	3	
18		114280041	BEARING-NEEDLE	57	
19		114280043	WASHER-THRUST	12	
20		605232001	CARRIER (1ST STG)	1	
21		114280047	SHAFT-PLANET	3	
22		114280049	WASHER-THRUST	1	
23		114280051	WASHER-THRUST	1	
24		605233001	GEAR-SUN	1	
25		901555057	SCREW-DRIVE #930301	2	
26		114280055	GEAR-RING/COVER	14	
27		605234001	PIPE PLUG-MAGN. NPTF	3	
28		114280057	BOLT-.313-18X1.25 GR8	12	
29		114280059	O-RING	1	
30		114280061	GEAR-SUN	1	
31		605235001	RET.RING-EXT.	1	
32		605236001	GEAR-SUN (3RD STG.)	1	
33		114280067	SPACER-THRUST	1	
34		114280069	RET.RING-EXT.	1	
35		114280071	RET.RING-INT.	1	
36		114280073	COUPLING	1	
37		114280075	BRAKE-INPUT	1	
38		605237001	PIPE PLUG SPECIAL	1	
39		901555055	PLATE-ID #901202	1	
40		114280003	PLUG-PLASTIC	1	
41		114280019	PIN-DOWEL	2	
42		602464001	PLANETARY-TRACK DRIVE	1	Inc All Items In Figure

Component-Idler Roller Fig 12-23

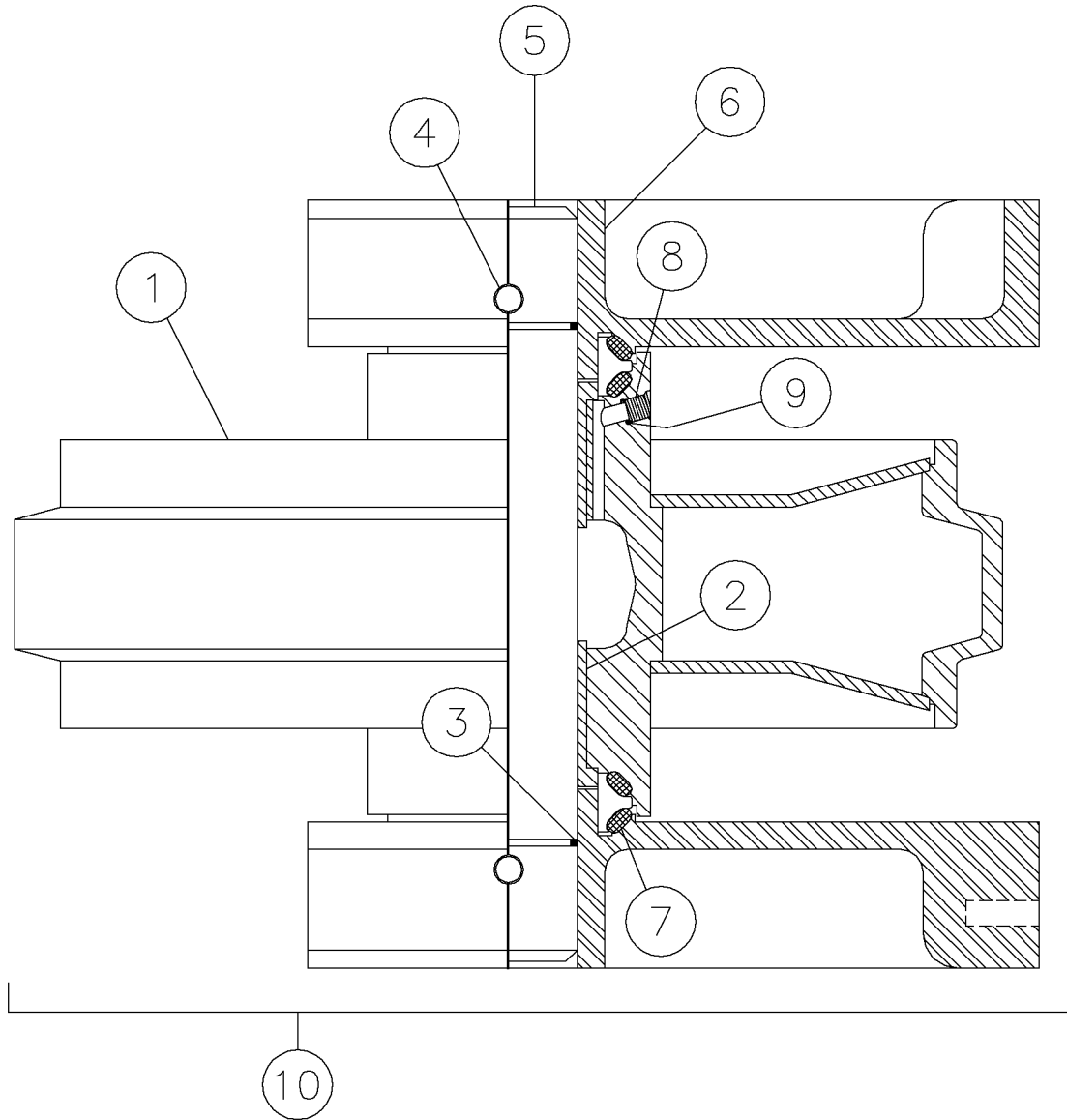

Component-Idler Roller Fig 12-23

REF. NO.	*	PART NO.	DESCRIPTION	QTY.	REMARKS
1		98680003	IDLER SHELL	1	
2		98680005	BUSHING	2	
3		98680007	GASKET	2	
4		98680009	DOWEL	2	
5		98680011	SHAFT	1	
6		98680013	BRACKET	2	
7		98680015	SEAL GROUP	2	
8		77967017	PLUG	1	
9		77967015	GASKET	1	
10		98680001	ROLLER-IDLER	1	Inc All Items In Figure

Component-Air Conditioner/Heater Fig 12-24

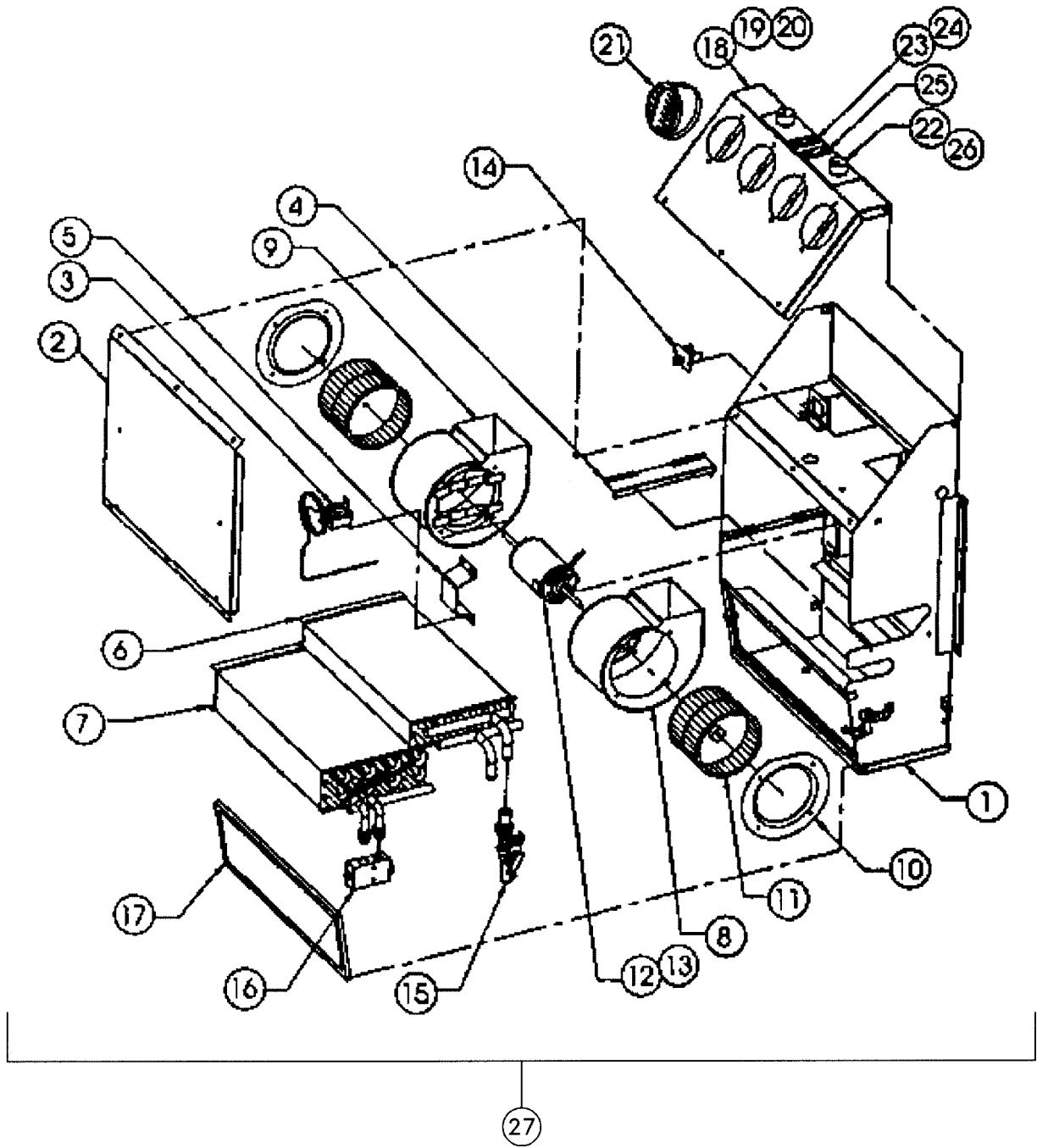

Component-Air Conditioner/Heater Fig 12-24

REF. NO.	*	PART NO.	DESCRIPTION	QTY.	REMARKS
1		296253439	HOUSING ASSY	1	
2		296253440	COVER ASSY-CORE	1	
3		296253441	THERMOSTAT	1	
4		296253442	RETAINER-CORE	1	
5		296253443	RETAINER-MOTOR	1	
6		296253444	HEATER CORE	1	
7		296253445	EVAPORATOR	1	
8		296253446	BLOWER ASSY (RH)	1	
9		296253447	BLOWER ASSY (LH)	1	
10		296253448	ENTRY RING	2	
11		296253449	BLOWER WHEEL	2	
12		296253450	MOTOR-12V	1	
13		296253451	MOTOR 24V	1	
14		296253452	RESISTOR	1	
15		296253453	WATER VALVE-CABLE OPERATED	1	
16		296253454	EXPANSION VALVE	1	
17		296253455	FILTER	1	
18		296253456	PLENUM ASSY-CNTRL PNL 12V	1	
19		296253457	PLENUM ASSY-CNTRL PNL 24V	1	
20		296253458	WRAP ASSY PLENUM	1	
21		296253459	AIR DIFFUSER ASSY	1	
22		296253460	CONVERTER-CABLE CONTROL	1	
23		296253461	SWITCH-ROCKER 12V	1	
24		296253462	SWITCH-ROCKER 24V	1	
25		296253463	SWITCH-ROCKER	1	
26		296253464	KNOB	2	
27		293570001	EVAPORATOR-AIR COND W/HEATER	1	Inc All Items In Figure

Component-Pump Drive (Not Available) Fig 12-25r01

FIGURE 12-25r01
NOT AVAILABLE

Component-Pump Drive (Not Available) Fig 12-25r01

REF. NO.	*	PART NO.	DESCRIPTION	QTY.	REMARKS
		Revision Date	October, 2004		Update In Illustration & Parts List.

Component-Pump Drive Fig 12-25

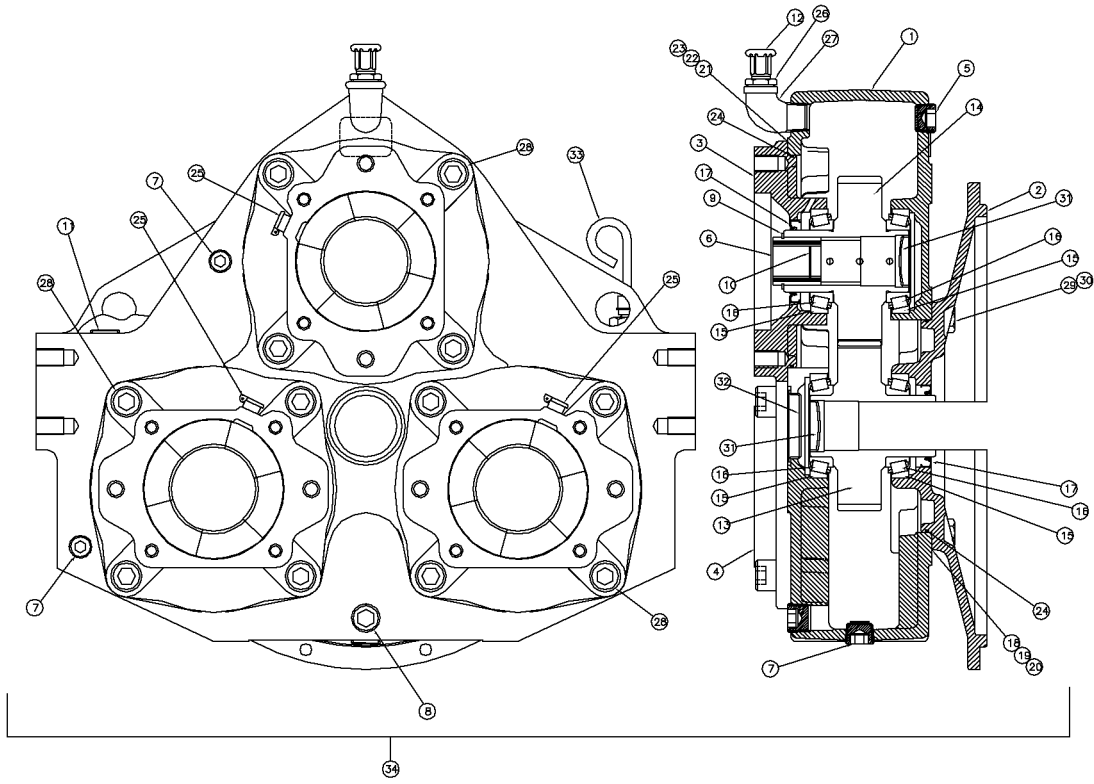

Component-Pump Drive Fig 12-25

REF. NO.	*	PART NO.	DESCRIPTION	QTY.	REMARKS
1		296261926	HOUSING	1	
2		296261927	ADAPTER - ENGINE	1	
3		200869004	FLANGE-PUMP	1	
4		85627021	FLANGE-PUMP	2	
5		3213017	PLUG-RELIEF 3/8"	1	
6		200869005	ADAPTER-SHAFT	1	
7		221652039	PIPE PLUG	3	
8		296261935	PLUG - MAGNETIC	1	
9		296261928	RETAINING RING	1	
10		208111001	RETAINER RING	1	
11		735001	3/4" COUNTERSUNK PIPE PLUG	2	
12		85627007	BREATHER	1	
13		902211011	GEAR-69T	1	
14		902211009	GEAR-49T	1	
15		296261929	BEARING CUP	8	
16		296261930	BEARING CONE	8	
17		902211017	SEAL	4	
18		85627009	SHIM-.005	2	
19		85627011	SHIM-.007	2	
20		85627013	SHIM-.020	1	
21		85627029	SHIM-.005	6	
22		85627031	SHIM-.007	6	
23		85627033	SHIM-.020	3	
24		296261931	O - RING	4	
25		296261935	PLUG - MAGNETIC	3	
26		730009	3/4"X 3/8" HEX BUSHING STEEL	1	
27		716007	3/4" X 90 DEG ST. EL.BLACK	1	
28		85627055	BOLT-3/4-10X1 1/2 SOCKET HEAD	12	
29		235737001	BOLT-1/2-13X1 1/4 GR8 ZINC PLT	6	
30		480011	WASHER-1/2 S/T LOCK	6	
31		85627023	PLUG	4	
32		296261933	EXPANSION PLUG	1	
33		296261934	DIPSTICK	1	
34		296261937	PUMP DRIVE	1	Inc All Items In Figure

Component- Joystick Fig 12-26

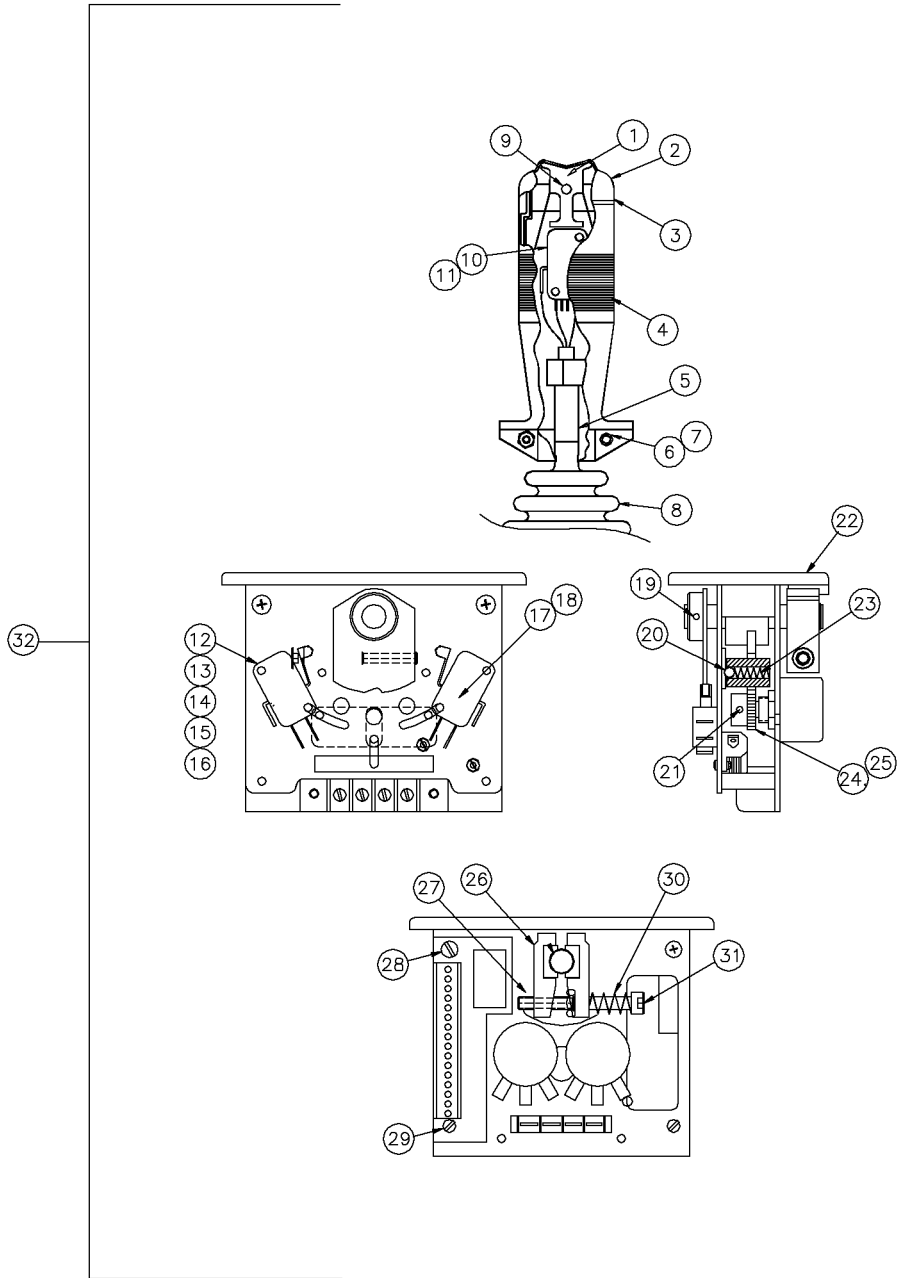

Component- Joystick Fig 12-26

REF. NO.	*	PART NO.	DESCRIPTION	QTY.	REMARKS
1		296253482	SWITCH ACTUATOR	1	
2		296253483	BOOT SEALING ACTUATOR	1	
3		296253484	BOOT RETAINING RING	1	
4		296253485	HANDLE (2 HALVES)	1	
5		204734009	LEVER	1	
6		296253486	NUT HEX METRIC M4	1	
7		296253487	SCREW SOCKET HEAD METRIC M4X10	1	
8		119701009	BOOT	1	
9		296253481	SCREW SOCKET HEAD METRIC M4 X 30	1	
10		296253479	SWITCH MICRO V3 - 115	1	
11		296253480	TAPE 2-SIDED FOAM	1	
12		67713001	SCREW- #12000956-001	4	
13		67715001	HARDWARE-MTG. #K00805	4	
14		234876003	SCREW-2-56X9/16	4	
15		89807005	PLATE-SPACER	2	
16		89807007	PLATE-MOUNTING (THREADED)	2	
17		96070013	SWITCH	2	
18		234876007	SWITCH-MICRO SUB MIN.	2	
19		296253478	SETSCREW METRIC CUP POINT M4-5.0	1	
20		296253488	BALL SS 0.219 DIA	1	
21		67722001	SET SCREW(4-40) #104859C	1	
22		119701007	COVER	1	
23		296253489	SPRING DETENT	1	
24		296253490	SPUR GEAR (FITS 0.250 DIA. SHAFT)	1	
25		296253491	SPINDLE NUT	1	
26		67716001	PAD-FRICTION #12499463-001	1	
27		296263303	NUT - LOCKING 10-32	1	
28		296253495	RETAINER RING	1	
29		296253492	SCREW PAN HEAD 4-40 X 5 /16	1	
30		67718001	SPRING- #12001001-001	1	
31		67719001	BOLT- #150162	1	
32		283107001	HANDLE - MAIN CONTROL	1	Inc All Items In Figure

Component-Seat Control Fig 12-27

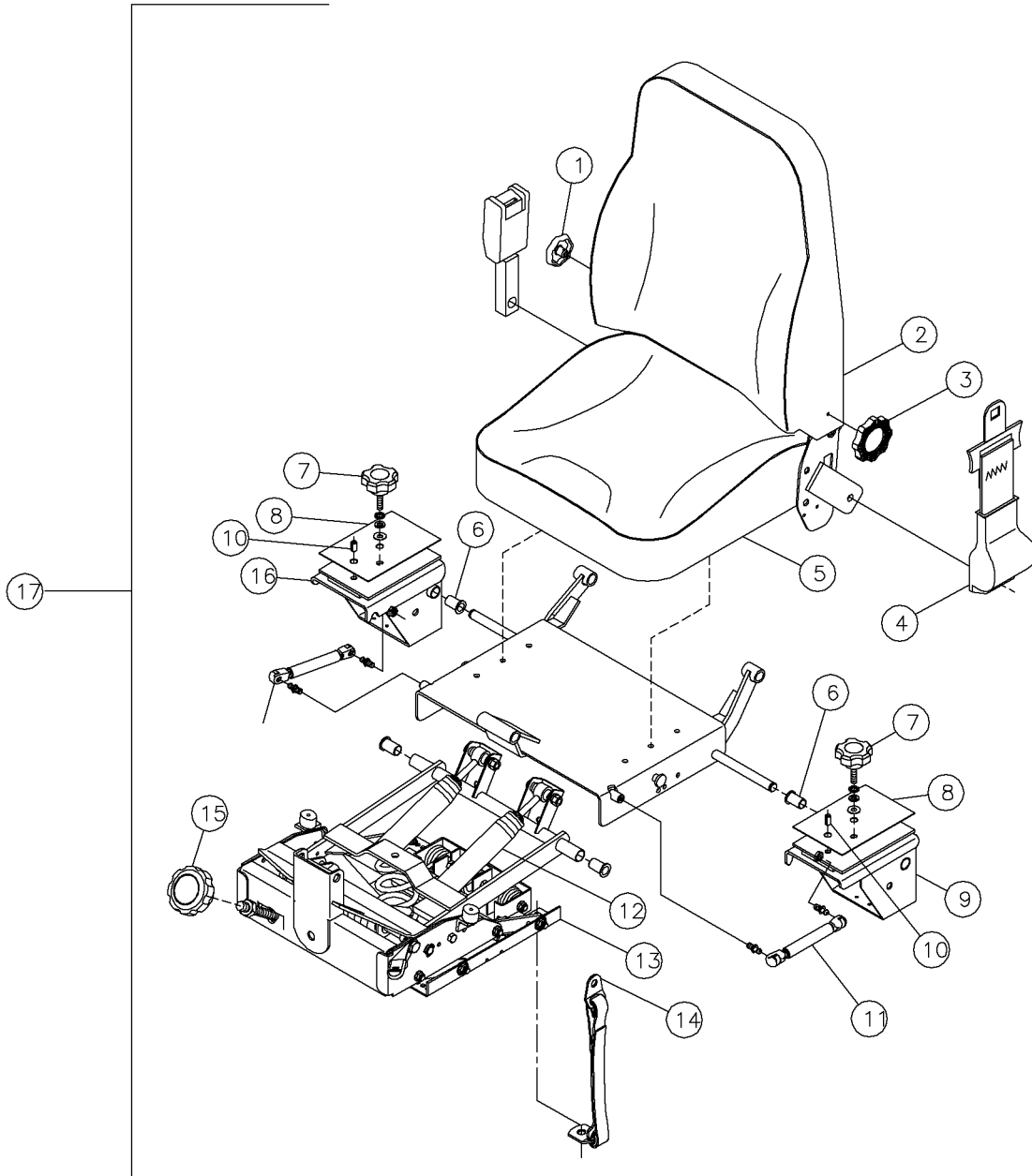

Component-Seat Control Fig 12-27

REF. NO.	*	PART NO.	DESCRIPTION	QTY.	REMARKS
1		296263270	KNOB - LUMBAR	1	
2		296263271	BACK COVER	1	
3		296263272	RECLINER KNOB & COMPONENTS	1	
4		296263273	BELT - 3" RETRACTABLE	1	
5		296263274	CUSHION ASSY W/SWITCH	1	
6		296263275	FLANGED BEARING	2	
7		296263276	CONTROL CARR LOCKING KNOB W/ HDWR	2	
8		296263277	PLASTIC SLIDER	2	
9		296263278	HOSE GUIDE - LH	1	
10		296263279	ROLL PIN	2	
11		296263280	GAS SPRING W/2 BALL STUDS	2	
12		296263281	SHOCK ABSORBER KIT	2	
13		296263282	EXTREME DUTY CHASSIS	1	
14		296263283	TETHER SET W/HDWR	1	
15		296263284	RIDE ADJUST KNOB	1	
16		296263285	HOSE GUIDE - RH	1	
17		283000001	SEAT-OPERATOR (MAGNUM 200)	1	Inc All Items In Figure

Component-Air Cleaner Fig 12-28

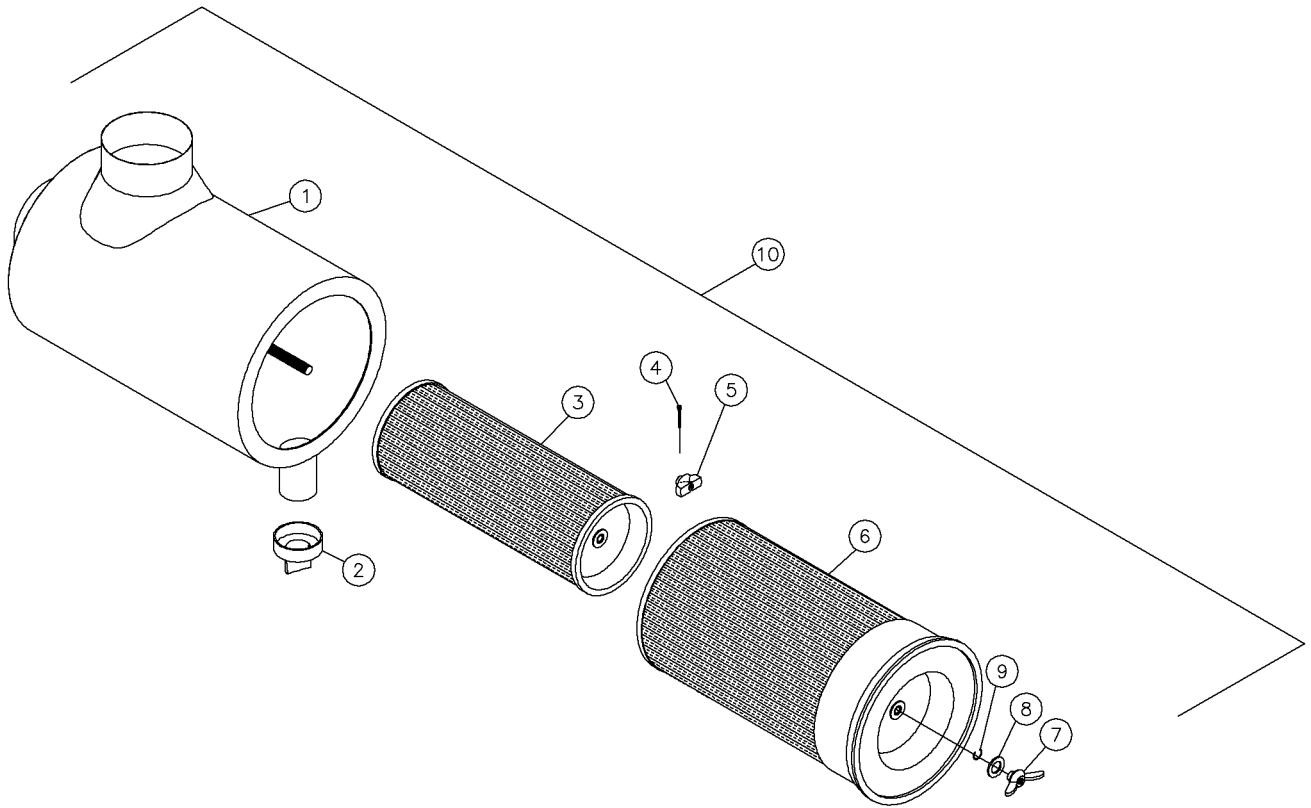

Component-Air Cleaner Fig 12-28

REF. NO.	*	PART NO.	DESCRIPTION	QTY.	REMARKS
1		NSS	BODY-AIR CLEANER	1	
2		296263296	VACUATOR VALVE	1	
3		296263297	ELEMENT	1	
4		510011	COTTER PIN-1/8" X 1 1/2"	1	
5		28918007	NUT ASSY-DONALDSON RNX00-4816	1	
6		296263298	ELEMENT	1	
7		296263300	WING NUT	1	
8		158854001	GASKET	1	
9		296263299	CLIP	1	
10		293636001	AIR CLEANER - FVG 160587	1	Inc All Items In Figure

Component- Oil Filter Fig 12-29

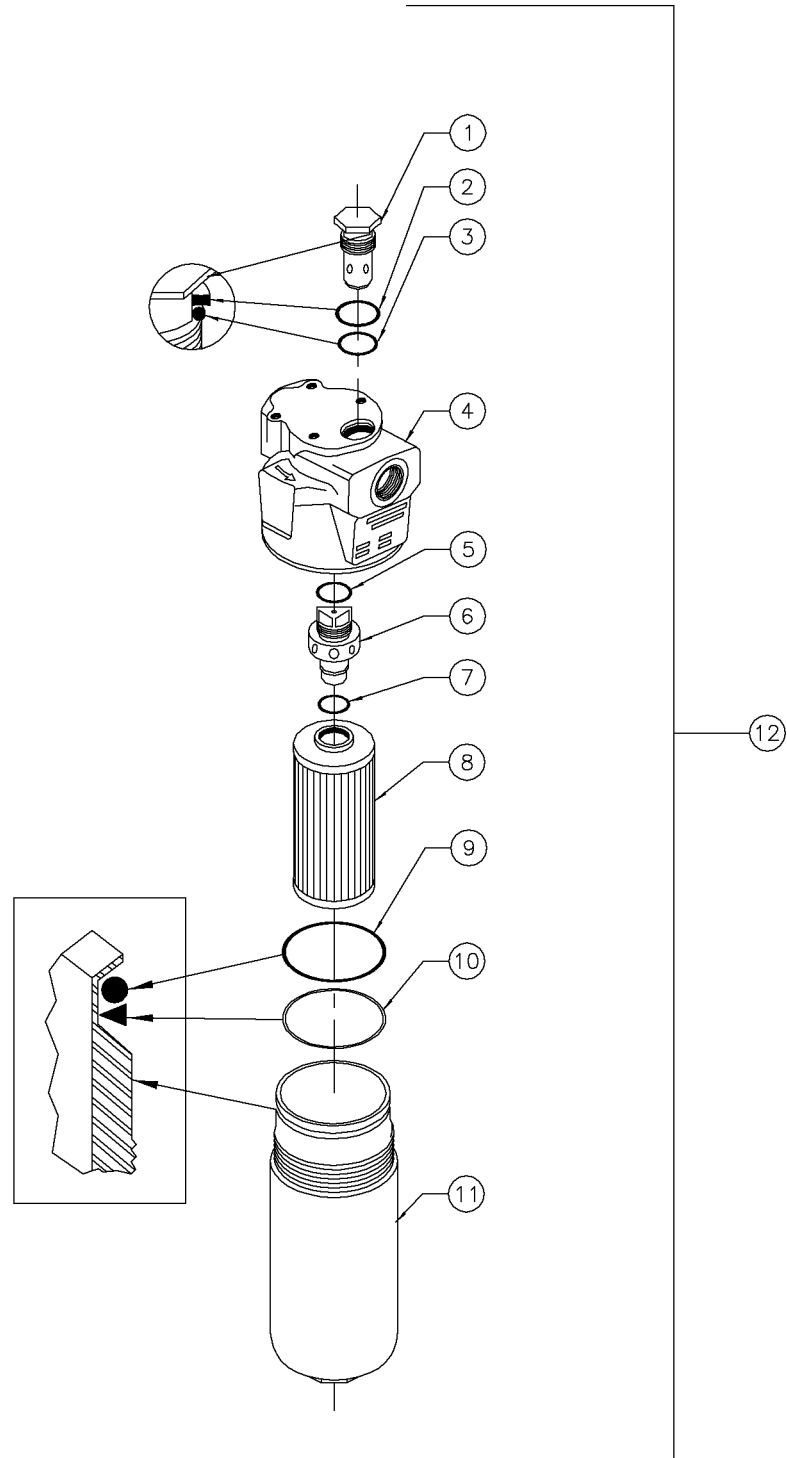

Component- Oil Filter Fig 12-29

REF. NO.	*	PART NO.	DESCRIPTION	QTY.	REMARKS
1		244560003	VALVE - BY-PASS	1	
2		244560005	RING - BY-PASS BACKUP	1	
3		296263301	SEAL - BY PASS HOUSING TO HEAD	1	
4		244560007	HEAD	1	
5		75353013	SEAL-HEAD/MANIFOLD	1	
6		244560009	VALVE - REVERSE FLOW	1	
7		244560011	SEAL - ELEMENT TO ADAPTER	1	
8		244560013	ELEMENT - FILTER	1	
9		244560015	SEAL - HEAD/BOWL	1	
10		224400005	RING-HEAD TO BOWEL	1	
11		296263302	BOWL	1	
12		296258288	FILTER - H.P. W/ INDICATOR - SAE 16	1	Inc All Items In This Figure

Components-Hose Carrier Fig 12-30r01

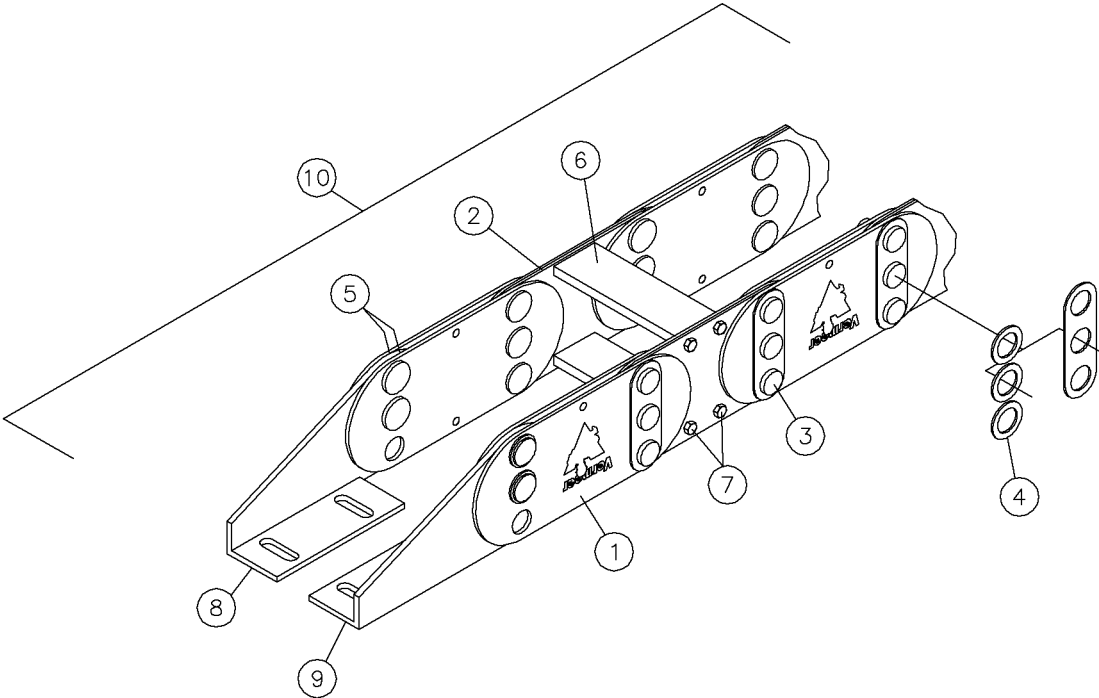

Components-Hose Carrier Fig 12-30r01

REF. NO.	*	PART NO.	DESCRIPTION	QTY.	REMARKS
		Revision Date	June, 2002		Update In Illustration & Parts List.
1		235608007	OUTER LINK W/ LOGO	40	
2		296267112	LINK-INNER PT35E	36	
3		235608015	HING PIN	108	
4		296267111	PT35E ONE PIECE PUSH ON	36	
5		235608011	ANTI-FRICTIN DISC	80	
6		296267110	ALUM. CHANNEL	18	
7		215252017	SCREW-WHIZ LOCK	72	
8		235608003	R.H. MOUNTING BRACKET	2	
9		235608005	L.H. MOUNTING BRACKET	2	
10	*	296265382	HOSE CARRIER-PT35E-19 PITCHES	1	Inc All Items In Figure

Components-Hose Carrier Fig 12-30

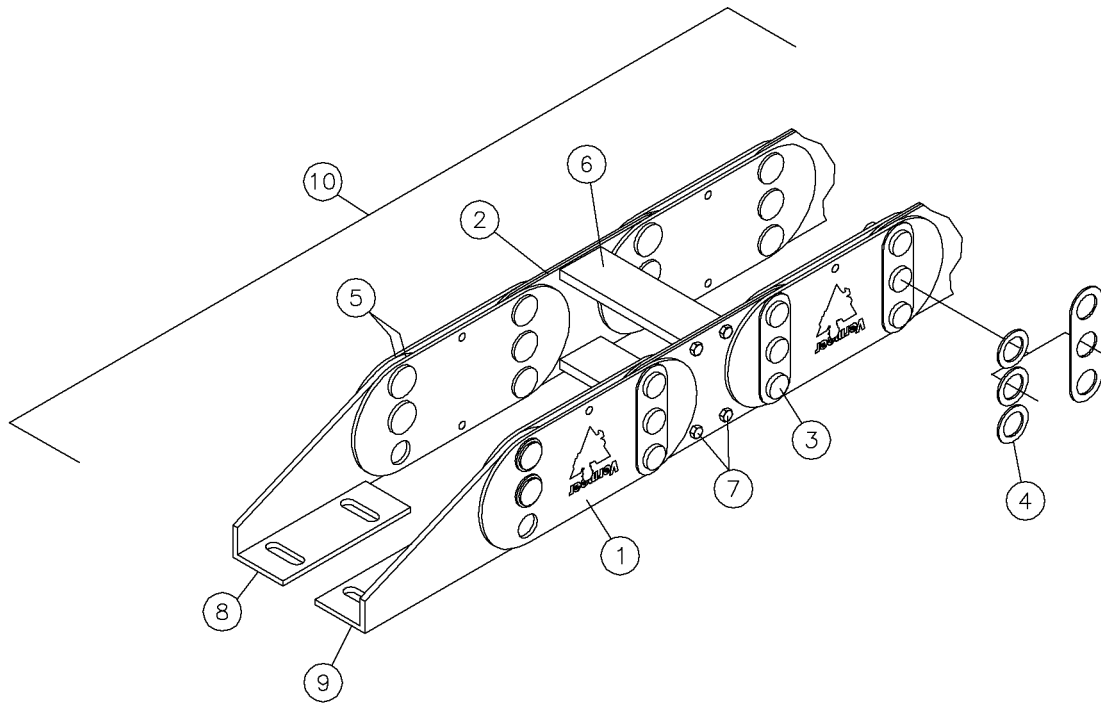

Components-Hose Carrier Fig 12-30

REF. NO.	*	PART NO.	DESCRIPTION	QTY.	REMARKS
1		296261994	PT28E OUTER LINK W/VERMEER LOGO	192	
2		296261995	PT28E INNER LINK	188	
3		215252021	HINGE PIN	564	
4		296261996	PT28E ONE PIECE PUSH ON	188	
5		215252019	ANTI-FRICTION DISC	384	
6		296261998	ALUM. CHANNEL 3.75 LG.	92	
7		296261999	BOLT -WHIZ LOCK	368	
8		296262000	PT28E MOUNTING BRACKET ASSY	2	
9		296264751	PT28E MOUNTING BRACKET ASSY	2	
10		277880001	HOSE CARRIER - PT28E - 95 PITCHES	1	Inc All Items In Figure

Component-Hose Carrier Fig 12-31

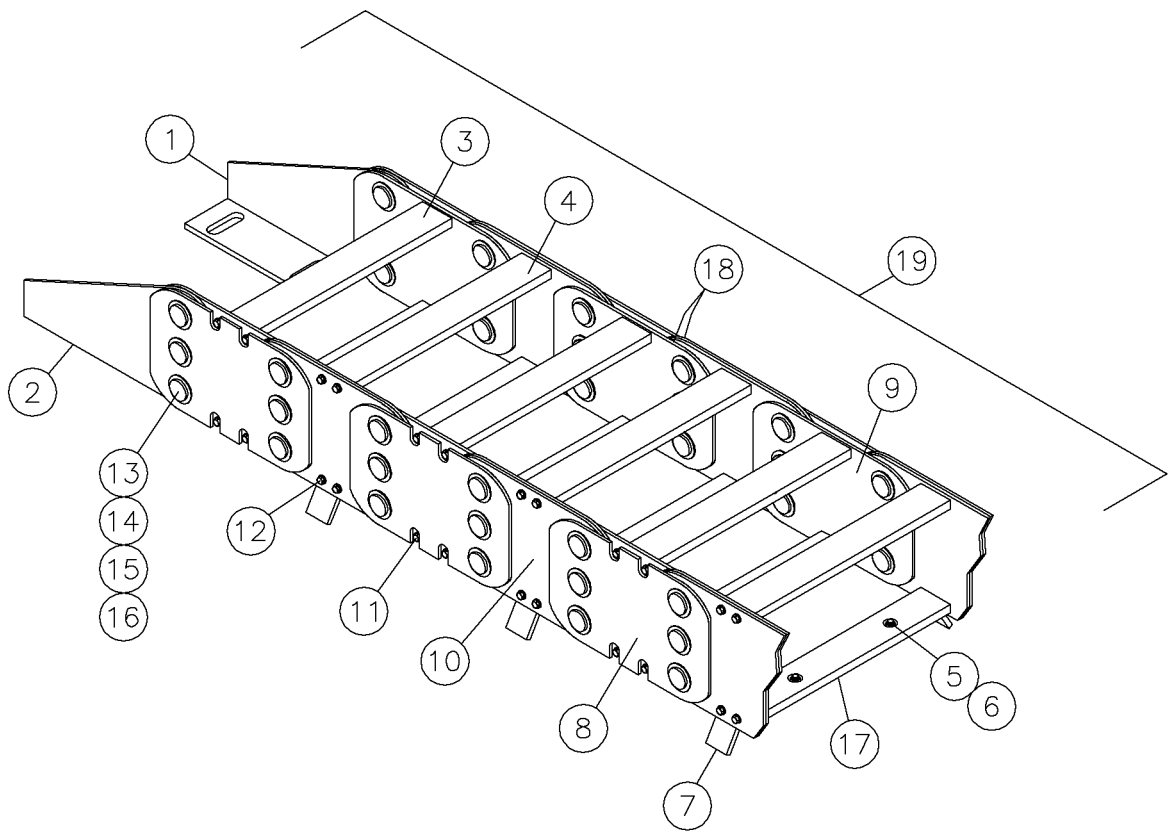

Component-Hose Carrier Fig 12-31

REF. NO.	*	PART NO.	DESCRIPTION	QTY.	REMARKS
1		296264764	PT60E MOUNTING BRACKET ASSY	2	
2		296264763	PT60E MOUNTING BRACKET ASSY	2	
3		296264761	ALUM. CHANNEL CARRIER	64	
4		296251022	CHANNEL - ALUM. 11.00"	31	
5		296251009	NUT - .25-20 ZINC ESAN	62	
6		296264765	SCREW - .25 - 20 X .63 LG SS	62	
7		296264773	NESTING BRACKET	31	
8		296264772	PT60E OUTER LINK CLEAR HOLES	64	
9		296264762	OUTER LINK - AC CARR. HOLES	64	
10		296264771	INNER LINK	124	
11		215252017	SCREW-WHIZ LOCK	256	
12		276280005	SCREW - WHIZ LOCK 10-32 X .62	248	
13		296264774	HINGE PIN	384	
14		296264770	RETAINING RING	768	
15		296264768	WASHER - SHIM .02 THK	384	
16		296264769	WASHER - SHIM .01 THK	384	
17		296264766	CHANNEL - ALUM. 11.00" SPCL.	31	
18		296264767	ANTI FRICTION PLATE	256	
19		277854001	HOSE CARRIER -- PT60E 63 PITCHES	1	Inc All Items In Figure

Component-Hose Carrier Fig 12-32

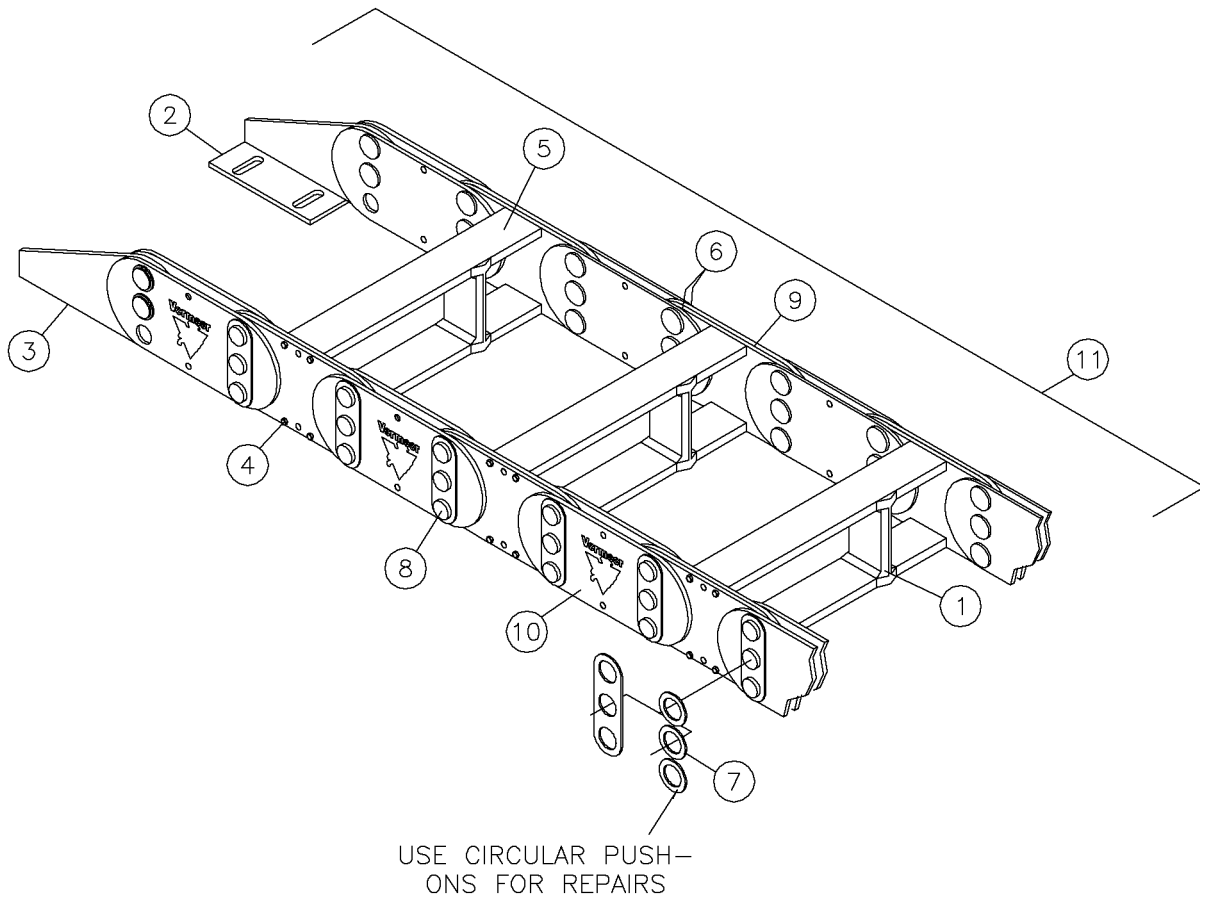

Component-Hose Carrier Fig 12-32

REF. NO.	*	PART NO.	DESCRIPTION	QTY.	REMARKS
1		296264752	SEPERATOR	27	
2		296264754	PT48E MOUNTING BRACKET ASSY	2	
3		296264753	PT48E MOUNTING BRACKET ASSY	2	
4		276280005	SCREW - WHIZ LOCK 10-32 X .62	216	
5		296264755	ALUM. CHNL. CARRIER 9.00	54	
6		296264756	ANTI FRICTION DISC	218	
7		296264757	PT48E ONE PIECE PUSH ON	106	
8		296264758	HINGE PIN	318	
9		296264759	PT48E INNER LINK	108	
10		296264760	PT48E OUTER LINK	108	
11		277855001	HOSE CARRIER - PT48E - 57 PITCHES	1	Inc All Items In Figure

Component-Floating Cushion Sub Fig 12-33

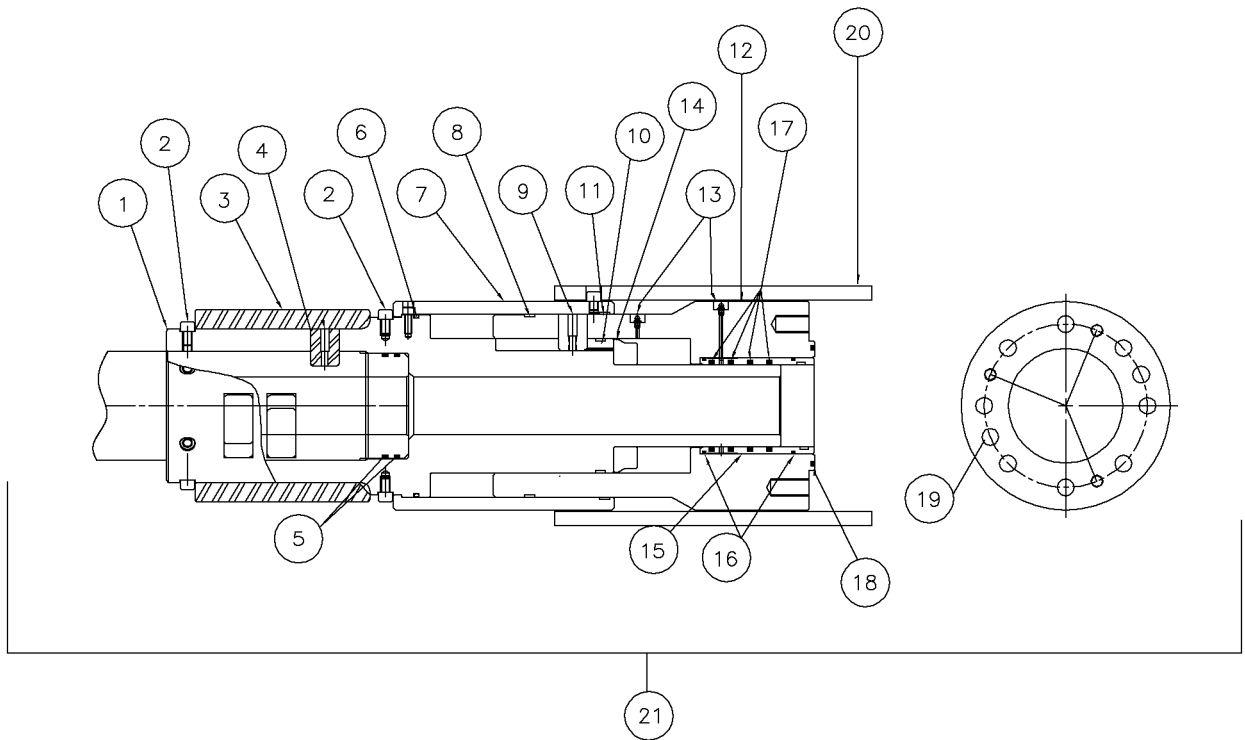

Component-Floating Cushion Sub Fig 12-33

REF. NO.	*	PART NO.	DESCRIPTION	QTY.	REMARKS
1		296263305	UPPER CONNECTION	1	
2		296263306	SHCS - 1/2 - 13NC X 3/4" LONG	12	
3		296263307	UPPER RETAINING RING	1	
4		296263308	SPIRAL WEDGELOCK KEYS	3	
5		296263309	O-RING - 70D NITRILE	2	
6		296263310	O-RING - 70 D NITRILE	1	
7		296263311	OUTER SLEEVE	1	
8		296263312	MOLYGARD WEAR RING	1	
9		296263313	INNER KEYS	3	
10		296263314	MOLYGARD WEAR RING	1	
11		296263315	MOLYGARD WEAR RING	1	
12		296263316	INNER SLEEVE	1	
13		296263317	1/4 - 28 GREASE FITTING	2	
14		296263318	URETHANE CUSHION	1	
15		296263319	PACKING CARTRIDGE	1	
16		296263320	O - RING - 70 D NITRILE	2	
17		296263321	POLYPAK - 4.75 X 4.25	4	
18		296263322	O - RING - 70 D NITRILE	1	
19		296263323	7/8 DOWEL PIN 3" - LG	2	
20		296263324	INDICATOR SLEEVE	1	
21		277857001	FLOATING CUSHION - SUB	1	Inc All Items In Figure

Component-Water Swivel Fig 12-34

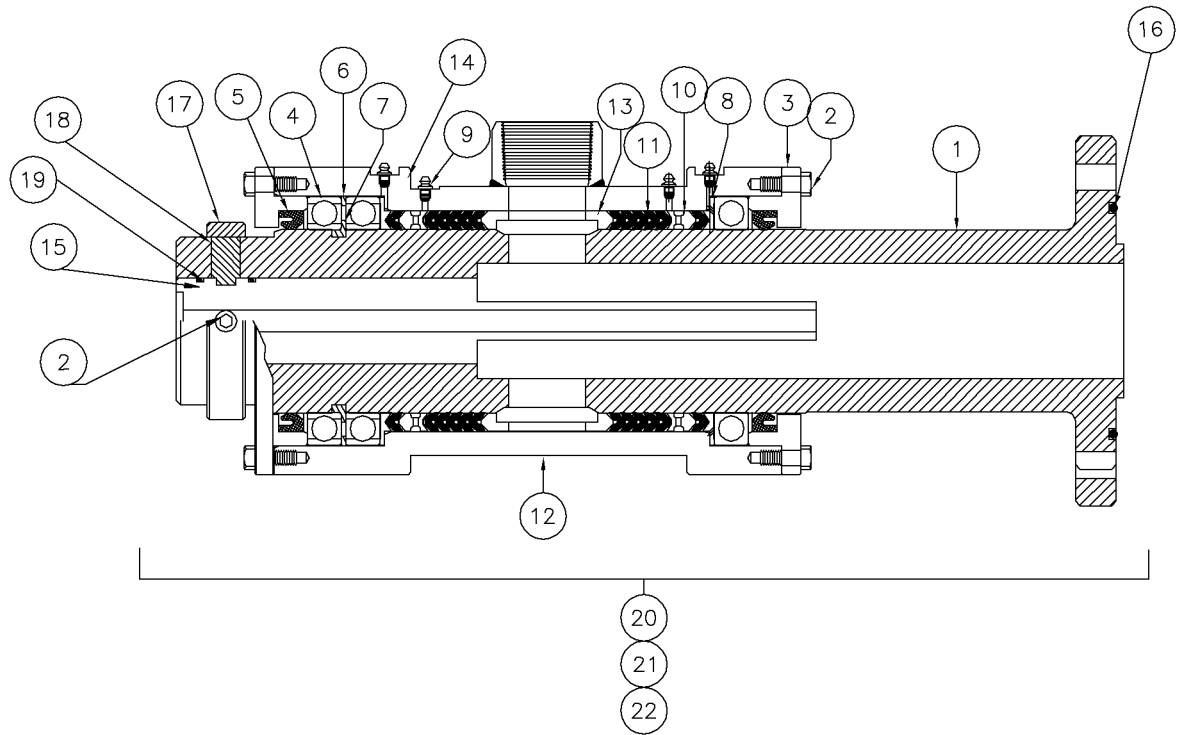

Component-Water Swivel Fig 12-34

REF. NO.	*	PART NO.	DESCRIPTION	QTY.	REMARKS
1		296264779	STEM - 9 5/8 OD FLANGE	1	
2		296264780	BOLTS - RETAINER	14	
3		296264781	END CAP	2	
4		296264782	BEARING XLS	3	
5		296264783	GREASE SEAL	2	
6		296264784	BEARING SPACER	1	
7		296264785	BEARING RETAINER	1	
8		296264786	PACKING - BACKUP RING	2	
9		296264787	GREASE FITTING	4	
10		296264788	GREASE RING	2	
11		296264789	PACKING RING SET	1	
12		296264790	BOLT - FLOW TUBE RETAINER	1	
13		296264791	FLOW TUBE	1	
14		296264792	SWIVEL HOUSING	1	
15		296264798	INNER TUBE - CIRCULATING	1	
16		296264794	O - RING	1	
17		296264795	OUTER RING	1	
18		296264796	RETAINING KEY	2	
19		296264797	O - RING SEAL	2	
20		228213001	SWIVEL-ROTATING HEAD MUD	1	Inc All Items In Figure
21		296264799	REPAIR KIT	1	Inc Four Of Ref No 9, Three Of Ref No 4, Two Of Ref No's 5 ,19 & One Of Ref No's 6 ,7 ,11 ,16
22		296264800	SEAL KIT	1	Inc Four Of Ref No 9, Two Of Ref No's 5, 19 & One Of Ref No's 11, 16

Component-Motor-Thrust/Pullback W/Brake Fig 12-35

THERE IS THE POSSIBILITY OF HAVING TWO SIZES OF PISTONS IN A MOTOR. NORMALLY CL "0" IS USED. THERE IS NO MARKING ON THE PISTON OR CYLINDER BLOCK. THERE IS THE POSSIBILITY OF HAVING CL "1" WHICH IS 1mm OVER SIZE. THERE WILL BE A "1" STAMPED ON THE PISTON AND A CORRESPONDING "1" STAMPED ON THE CYLINDER BLOCK IN THE AREA OF THE EFFECTED CYLINDER BORE.

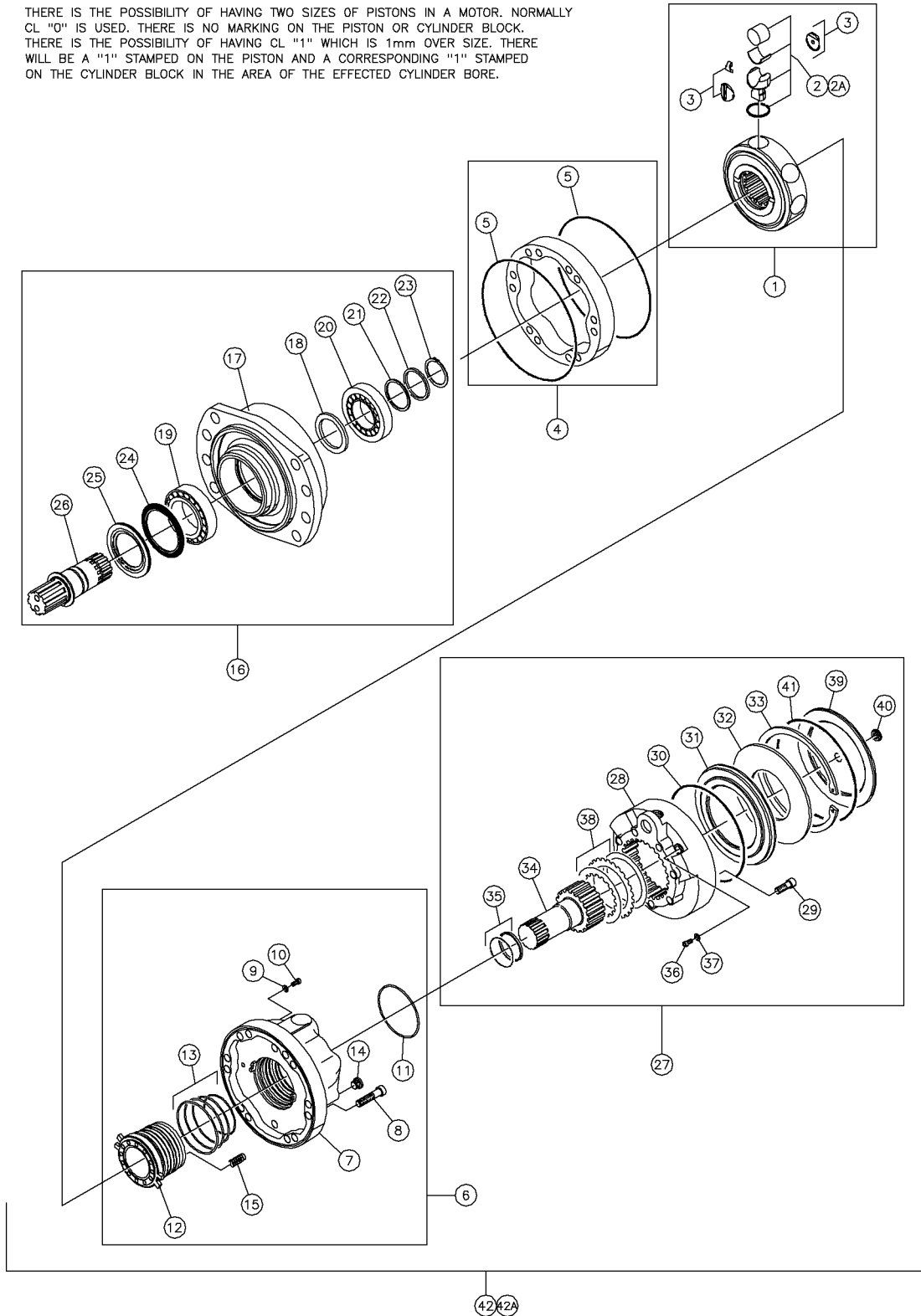

Component-Motor-Thrust/Pullback W/Brake Fig 12-35

REF. NO.	*	PART NO.	DESCRIPTION	QTY.	REMARKS
1		99098005	CYLINDER BLOCK	1	
2		119885001	MOTOR-WHEEL D68437.45D	A/R	P/N Qty Of 1 = 1
2A		296251951	PISTON - CL.1	A/R	P/N Qty Of 1 = 1
3		119885005	REPAIR KIT-PISTON	1	
4		216674003	CAM ASSEMBLY	1	
5		99098013	O-RING-3.50 X 314	2	
6		296251952	VALVE COVER ASSEMBLY		
7		296251954	VALVING COVER	1	
8		254642013	SCREW-BOLT	16	
9		64078025	WASHER	2	
10		64078027	SCREW-BLEEDING	2	
11		83651025	O-RING-2.62X145.72	1	
12		296251953	VALVING DISTRIBUTOR	1	
13		84550025	VALVE SEAL SET	1	
14		296251955	PLUG	2	
15		84550029	SPRING	12	
16		296251956	BEARING SUPPORT ASSY	1	
17		296251957	BEARING SUPPORT	1	
18		99098025	SEAL	1	
19		99098027	OUTER BEARING	1	
20		99098029	INNER BEARING	1	
21		84550069	SHIM SET	1	
22		84550071	WASHER	1	
23		84550073	SNAP RING	1	
24		99098031	SEAL	1	
25		99098033	DEFLECTOR	1	
26		296251958	SHAFT	1	
27		296251959	DISC BRAKE ASSEMBLY	1	
28		296251960	BRAKE BODY	1	
29		296251961	BOLT	10	
30		608489001	O-RING	1	
31		296251962	BRAKE PISTON	1	
32		296251963	WASHER - SPRING	1	
33		608492001	SNAP RING	1	
34		296251964	SHAFT	1	
35		296251965	SEAL KIT	1	
36		64078027	SCREW-BLEEDING	2	
37		64078025	WASHER	2	
38		296251966	BRAKE DISC	1	
39		296251967	PROJECTOR	1	
40		608498001	PLUG	1	
41		608499001	O-RING	1	
42		277956001	MOTOR-MS18-2-117-F19-2A10-5000	1	Inc All Items In Figure
42A		99098003	SEAL KIT	1	Inc Ref No's 5, 9, 11, 13, 18, 22, 24, 25, 30, 35, 37

Component-Motor-Thrust/Pullback WO/Brake Fig 12-36

THERE IS THE POSSIBILITY OF HAVING TWO SIZES OF PISTONS IN A MOTOR. NORMALLY CL "0" IS USED. THERE IS NO MARKING ON THE PISTON OR CYLINDER BLOCK. THERE IS THE POSSIBILITY OF HAVING CL "1" WHICH IS 1mm OVER SIZE. THERE WILL BE A "1" STAMPED ON THE PISTON AND A CORRESPONDING "1" STAMPED ON THE CYLINDER BLOCK IN THE AREA OF THE EFFECTED CYLINDER BORE.

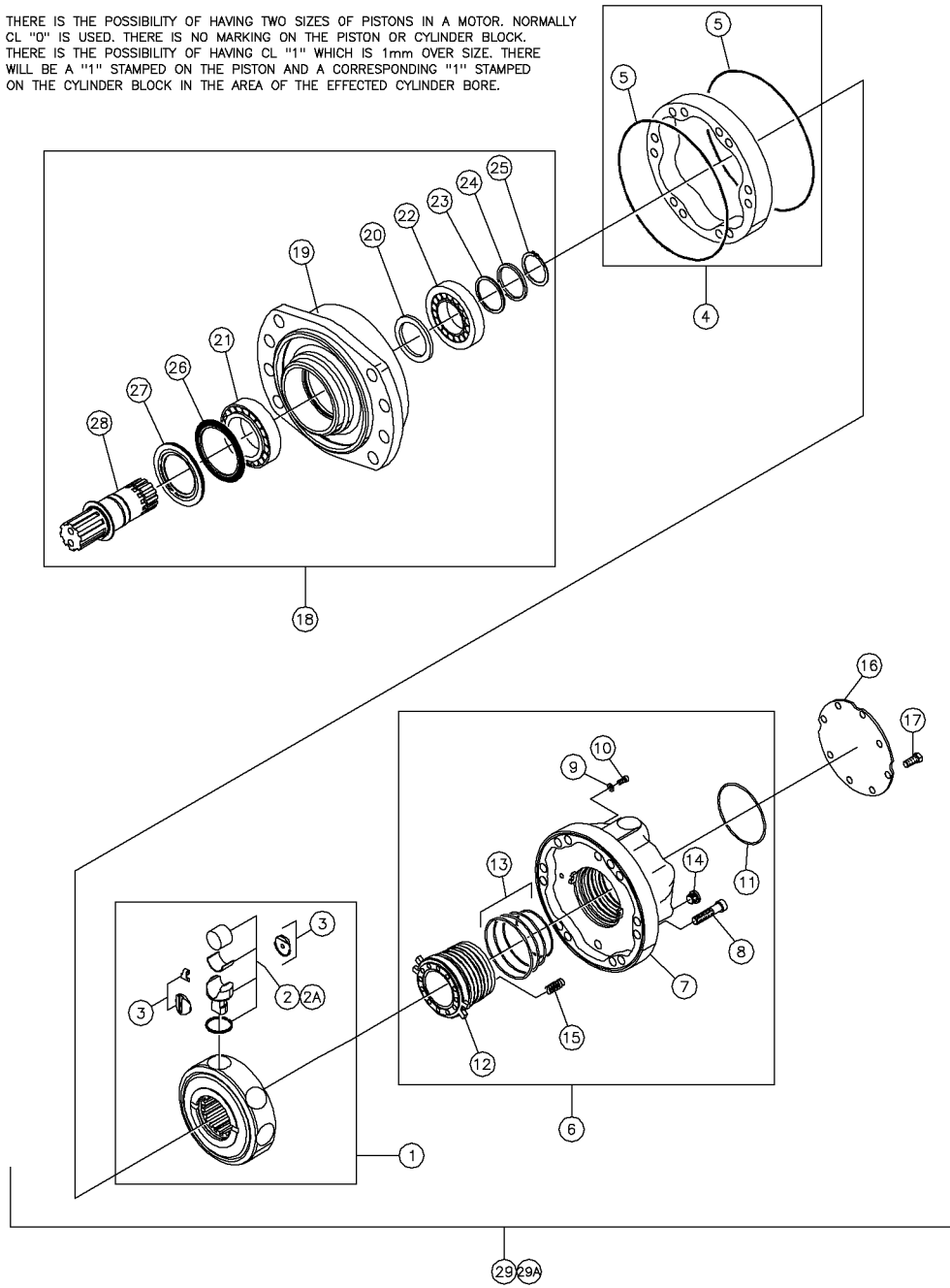

Component-Motor-Thrust/Pullback WO/Brake Fig 12-36

REF. NO.	*	PART NO.	DESCRIPTION	QTY.	REMARKS
1		99098005	CYLINDER BLOCK	1	
2		119885003	PISTON CL"O XCX	A/R	P/N Qty Of 1 = 1
2A		296251951	PISTON - CL.1	A/R	P/N Qty Of 1 = 1
3		119885005	REPAIR KIT-PISTON	1	
4		216674003	CAM ASSEMBLY	1	
5		99098013	O-RING-3.50 X 314	2	
6		296251952	VALVE COVER ASSEMBLY	1	
7		296251954	VALVING COVER	1	
8		254642013	SCREW-BOLT	16	
9		64078025	WASHER	2	
10		64078027	SCREW-BLEEDING	2	
11		83651025	O-RING-2.62X145.72	1	
12		296251953	VALVING DISTRIBUTOR	1	
13		84550025	VALVE SEAL SET	1	
14		296251955	PLUG	2	
15		84550029	SPRING	12	
16		83651055	PLATE-REAR COVER	1	
17		254642019	SCREW-BOLT	5	
18		296251956	BEARING SUPPORT ASSY	1	
19		296251957	BEARING SUPPORT	1	
20		99098025	SEAL	1	
21		99098027	OUTER BEARING	1	
22		99098029	INNER BEARING	1	
23		84550069	SHIM SET	1	
24		84550071	WASHER	1	
25		84550073	SNAP RING	1	
26		99098031	SEAL	1	
27		99098033	DEFLECTOR	1	
28		296251958	SHAFT	1	
29		277955001	MOTOR-MS18-2-117-A18-2A10-5000	1	Inc All Items In Figure
29A		99098003	SEAL KIT	1	Inc Ref No's 5, 9, 11, 13, 20, 24, 26, 27

Component-Motor-Rotation W/Brake Fig 12-37

THERE IS THE POSSIBILITY OF HAVING TWO SIZES OF PISTONS IN A MOTOR. NORMALLY CL "0" IS USED. THERE IS NO MARKING ON THE PISTON OR CYLINDER BLOCK. THERE IS THE POSSIBILITY OF HAVING CL "1" WHICH IS 1mm OVER SIZE. THERE WILL BE A "1" STAMPED ON THE PISTON AND A CORRESPONDING "1" STAMPED ON THE CYLINDER BLOCK IN THE AREA OF THE EFFECTED CYLINDER BORE.

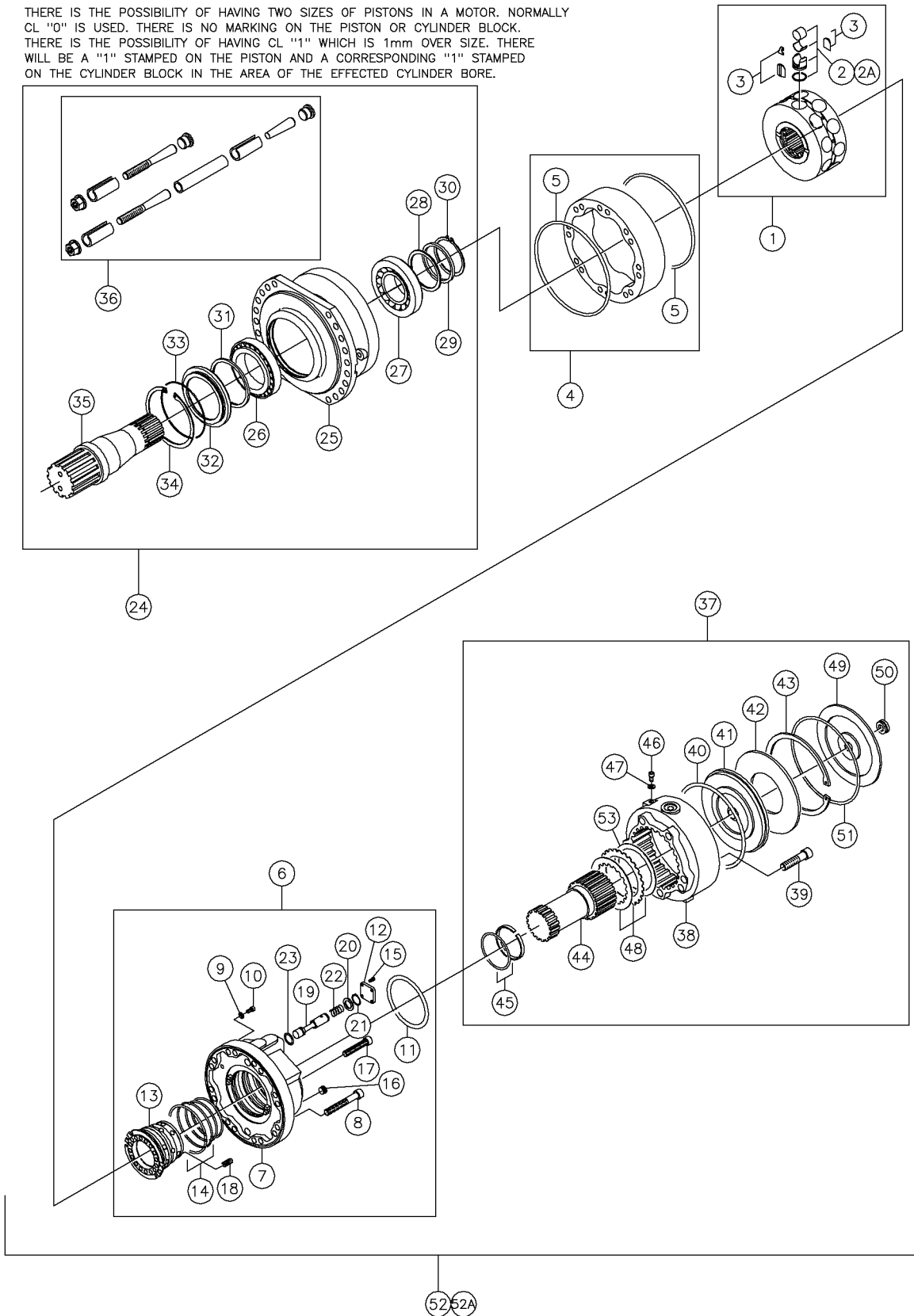

Component-Motor-Rotation W/Brake Fig 12-37

REF. NO.	*	PART NO.	DESCRIPTION	QTY.	REMARKS
1		296251968	CYLINDER BLOCK	1	
2		119885003	PISTON CL"O XCX	A/R	P/N Qty Of 1 = 1 Each
2A		296251969	PISTON - CL. 1	A/R	P/N Qty Of 1 = 1 Each
3		296251970	REPAIR KIT	1	
4		84550011	CAM	1	
5		99098013	O-RING-3.50 X 314	2	
6		296251971	VALVING COVER ASSEMBLY	1	
7		296251972	VALVING COVER	1	
8		296251973	BOLT	12	
9		64078025	WASHER	1	
10		64078027	SCREW-BLEEDING	1	
11		84550021	O-RING-3.53X183.74	1	
12		296251974	COVER	1	
13		296251975	VALVING DISTRIBUTOR	1	
14		84550025	VALVE SEAL SET	1	
15		84550047	SCREW-M16X25	4	
16		296251976	PLUG	1	
17		296251977	BOLT	2	
18		84550029	SPRING	12	
19		296251978	VALVE SPOOL	1	
20		296251979	WASHER	1	
21		296251980	SNAP RING	1	
22		296251981	SPRING	1	
23		84550041	O-RING 2.62X48.90	1	
24		296251984	BEARING SUPPORT ASSEMBLY	1	
25		296251985	BEARING SUPPORT	1	
26		296251986	BEARING	1	
27		99098029	INNER BEARING	1	
28		84550069	SHIM SET	1	
29		84550071	WASHER	1	
30		84550073	SNAP RING	1	

Component-Motor-Rotation W/Brake (Continued) Fig 12-37

THERE IS THE POSSIBILITY OF HAVING TWO SIZES OF PISTONS IN A MOTOR. NORMALLY CL "0" IS USED. THERE IS NO MARKING ON THE PISTON OR CYLINDER BLOCK. THERE IS THE POSSIBILITY OF HAVING CL "1" WHICH IS 1mm OVER SIZE. THERE WILL BE A "1" STAMPED ON THE PISTON AND A CORRESPONDING "1" STAMPED ON THE CYLINDER BLOCK IN THE AREA OF THE EFFECTED CYLINDER BORE.

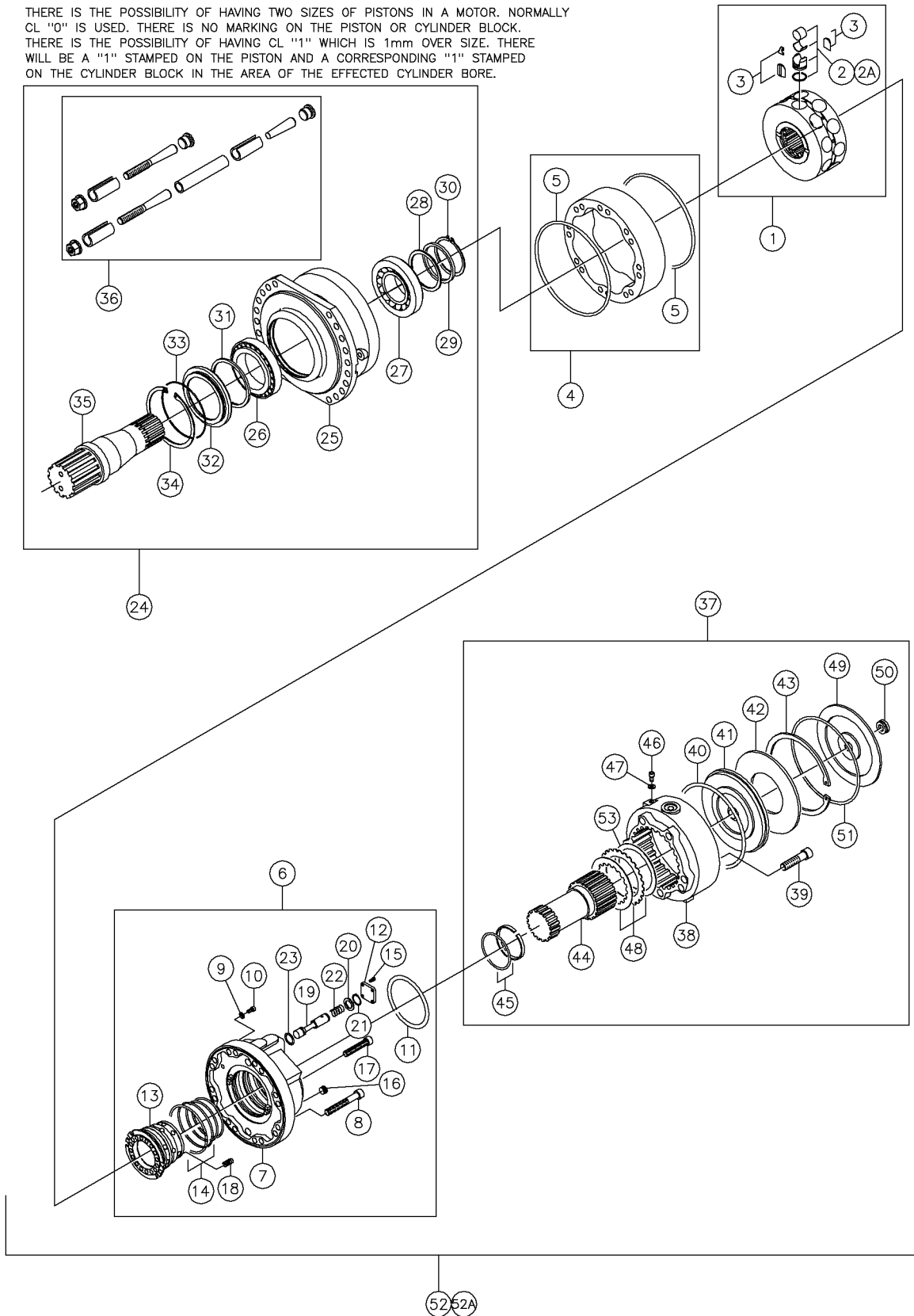

Component-Motor-Rotation W/Brake (Continued) Fig 12-37

REF. NO.	*	PART NO.	DESCRIPTION	QTY.	REMARKS
31		296251987	SEAL RING -RUBBER	1	
32		296251988	COVER	1	
33		296251989	O - RING	1	
34		296251990	SNAP RING	1	
35		296251991	SHAFT	1	
36		296251992	SAFETY PINS	1	
37		296251995	DISC BRAKE ASSEMBLY	1	
38		296251996	BRAKE BODY	1	
39		296251997	BOLT	8	
40		296251999	O - RING	1	
41		296252000	BRAKE PISTON	1	
42		296265501	WASHER - SPRING	1	
43		296265502	SNAP RING	1	
44		296265503	SHAFT	1	
45		296265504	SEAL	1	
46		64078027	SCREW-BLEEDING	2	
47		64078025	WASHER	2	
48		296265505	BRAKE DISC	1	
49		296265506	PROTECTOR	1	
50		278973023	PLUG	1	
51		296265507	O - RING	1	
52		296258350	MOTOR - MS35 - 9 - G17 - P35 - 2A10 - 5000	1	Inc All Items In Figure
52A		296251994	SEAL KIT	1	Inc Ref No's 5, 9, 11, 14, 23, 29, 31, 33, 40, 45, 47, 49, 50, 51
53		296251998	BRAKE SHIMS	1	

Component-Motor-Rotation WO/Brake Fig 12-38

THERE IS THE POSSIBILITY OF HAVING TWO SIZES OF PISTONS IN A MOTOR. NORMALLY CL "0" IS USED. THERE IS NO MARKING ON THE PISTON OR CYLINDER BLOCK. THERE IS THE POSSIBILITY OF HAVING CL "1" WHICH IS 1mm OVER SIZE. THERE WILL BE A "1" STAMPED ON THE PISTON AND A CORRESPONDING "1" STAMPED ON THE CYLINDER BLOCK IN THE AREA OF THE EFFECTED CYLINDER BORE.

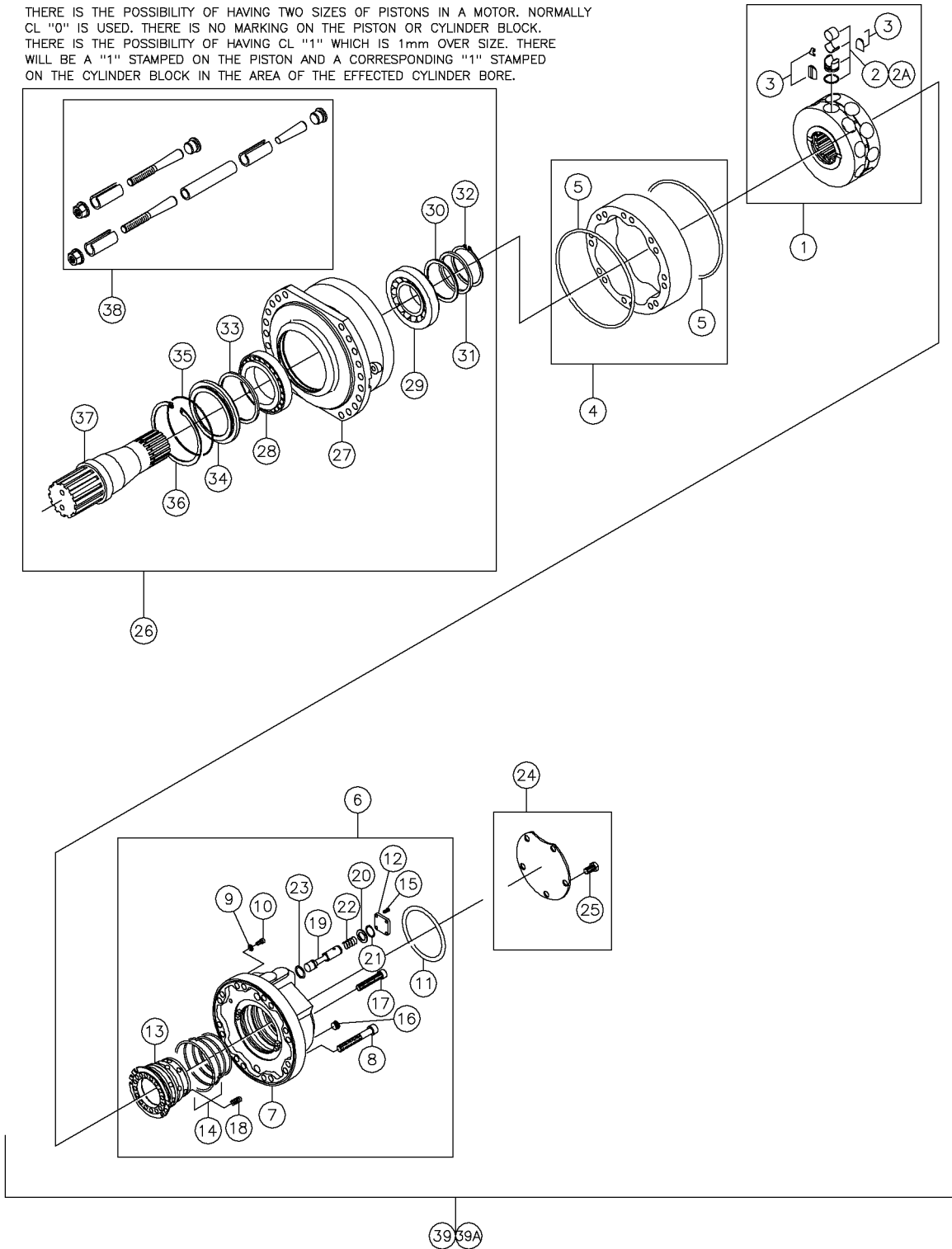

Component-Motor-Rotation WO/Brake Fig 12-38

REF. NO.	*	PART NO.	DESCRIPTION	QTY.	REMARKS
1		296251968	CYLINDER BLOCK	1	
2		119885003	PISTON CL"O XCX	A/R	P/N Qty Of 1 = 1
2A		296251969	PISTON - CL. 1	A/R	P/N Qty Of 1 = 1
3		296251970	REPAIR KIT	1	
4		84550011	CAM	1	
5		99098013	O-RING-3.50 X 314	2	
6		296251971	VALVING COVER ASSEMBLY	1	
7		296251972	VALVING COVER	1	
8		296251973	BOLT	12	
9		64078025	WASHER	1	
10		64078027	SCREW-BLEEDING	1	
11		84550021	O-RING-3.53X183.74	1	
12		296251974	COVER	1	
13		296251975	VALVING DISTRIBUTOR	1	
14		84550025	VALVE SEAL SET	1	
15		84550047	SCREW-M16X25	4	
16		296251976	PLUG	1	
17		296251977	BOLT	2	
18		84550029	SPRING	12	
19		296251978	VALVE SPOOL	1	
20		296251979	WASHER	1	
21		296251980	SNAP RING	1	
22		296251981	SPRING	1	
23		84550041	O-RING 2.62X48.90	1	
24		296251982	BACK PLATE ASSEMBLY	1	
25		296251983	BOLT	5	
26		296251984	BEARING SUPPORT ASSEMBLY	1	
27		296251985	BEARING SUPPORT	1	
28		296251986	BEARING	1	
29		99098029	INNER BEARING	1	
30		84550069	SHIM SET	1	
31		84550069	SHIM SET	1	
32		84550073	SNAP RING	1	
33		296251987	SEAL RING -RUBBER	1	
34		296251988	COVER	1	
35		296251989	O - RING	1	
36		296251990	SNAP RING	1	
37		296251991	SHAFT	1	
38		296251992	SAFETY PINS	1	
39		277849001	MOTOR - MS35 - 9 -D17 - A35 - 2A10 - 5000	1	Inc All Items In Figure
39A		296251994	SEAL KIT	1	Inc Ref No's 5, 9, 11, 14, 23, 31, 33, 35

Components-Vise Assy Fig 12-39

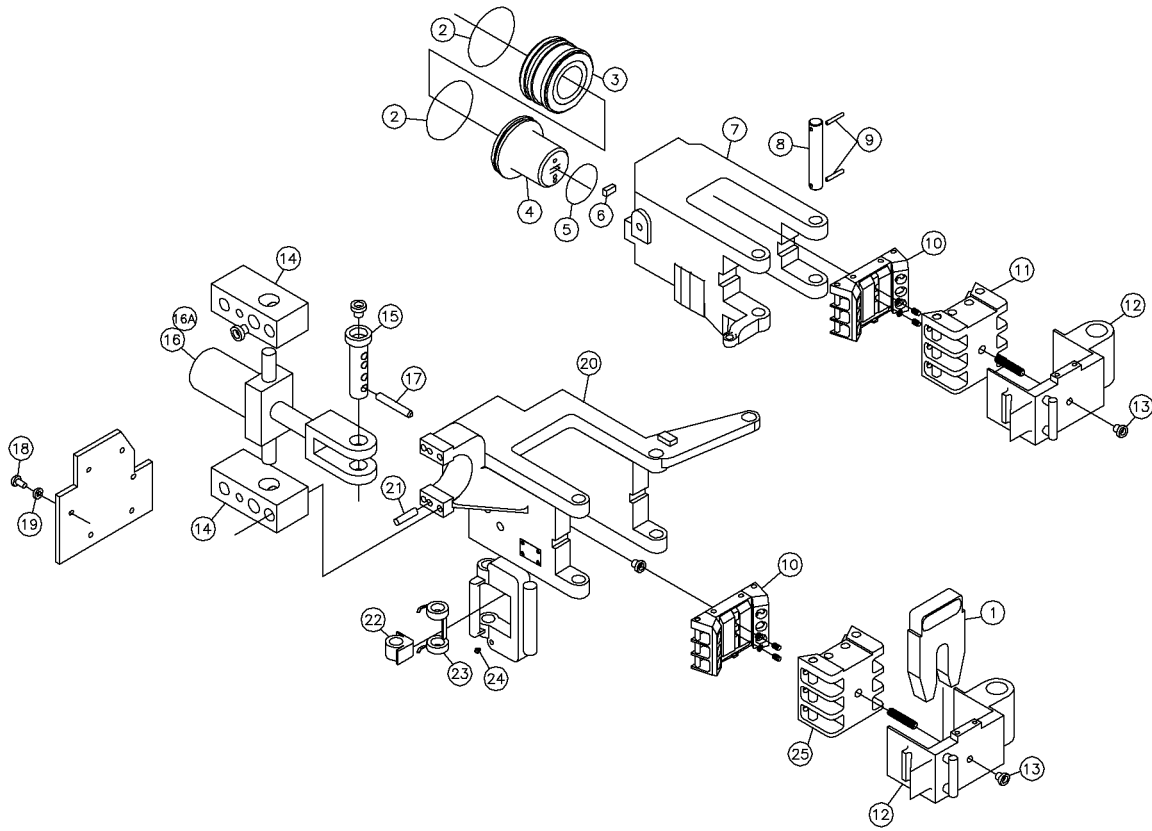

Components-Vise Assy Fig 12-39

REF. NO.	*	PART NO.	DESCRIPTION	QTY.	REMARKS
2		296263371	RING - CYLINDER HEAD	2	
3		296263370	HEAD - CYLINDER	1	
4		296263372	PISTON	1	
5		296263373	RING - SCRAPER	1	
6		296263337	KEY	2	
7		296263352	BODY - UPPER AND LOWER	2	
8		296263339	PIN - HINGE	4	
9		296263338	PIN - ROLL	4	
10		296263336	JAW ASSEMBLY - PISTON	2	Breakdown Fig 12-40
11		296263333	JAW ASSEMBLY - UPPER GATE	1	Breakdown Fig 12-40
12		296263341	GATE - MODIFIED	2	
13		296263332	SLEEVE	2	
14		296263347	BLOCK - PILLOW	4	
16		296263349	CYLINDER - TORQUE HYDRAULIC	2	
16A		296263392	SEAL KIT	1	
17		296263345	PIN - COTTER	4	
21		296263348	PIN - DOWEL	4	
22		296263344	STOP - LATCH	2	
23		296263342	SPRING - TORSION	2	
24		296263340	FITTING - GREASE	12	
25		296263334	JAW ASSEMBLY - LOWER GATE	1	Breakdown Fig 12-40

Component-Upper Jaw/Lower Jaw/Piston Jaw Assy Fig 12-40

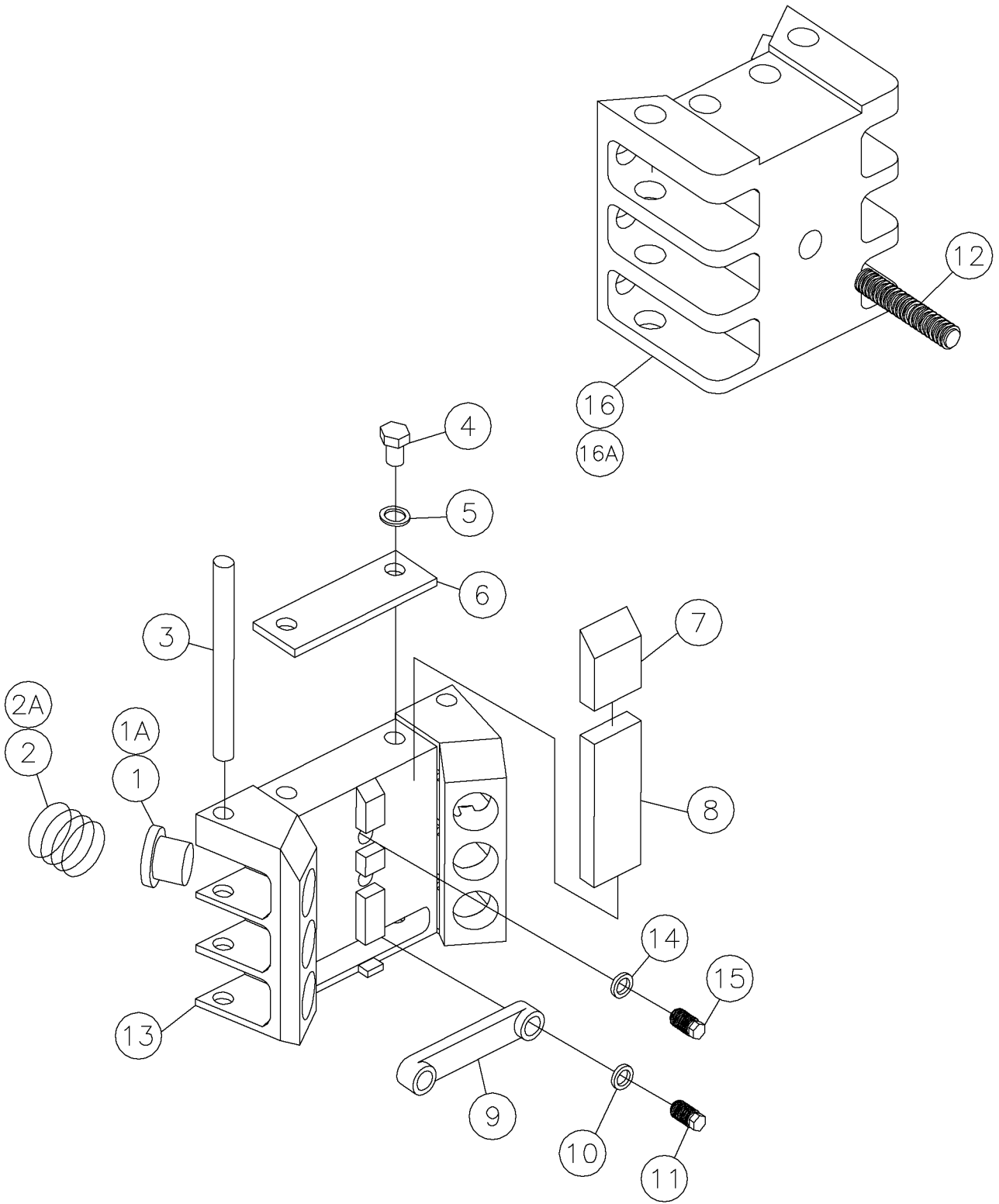

Component-Upper Jaw/Lower Jaw/Piston Jaw Assy Fig 12-40

REF. NO.	*	PART NO.	DESCRIPTION	QTY.	REMARKS
1		296263363	BUTTON - SPRING RETAINER	6	
1A		296263367	BUTTON SPRING RETAINER	6	
2		296263362	SPRING - HELICAL	6	
2A		296263366	SPRING HELICAL GATE	6	
3		296263361	PIN - SPRING RETAINER	2	
4		296263353	SCREW - HEX - HD CAP	2	
5		296263354	LOCKWASHER	2	
6		296263355	RETAINER - DIE	1	
7		296263356	SPACER - DIE	2	
8		296263357	DIE - TONG	2	
9		296263360	RETAINER - DIE	1	
10		296263359	LOCKWASHER	2	
11		296263358	SCREW - HEX - HD CAP	2	
12		296263364	ROD - THREADED	1	
13		NSS	JAW-PISTON	1	
14		296263365	SCREW - HEX - HD CAP	2	
15		296263366	SPRING HELICAL GATE	2	
16		NSS	JAW-UPPER GATE	1	
16A		NSS	JAW-LOWER GATE	1	

Component-Gearbox Fig 12-41

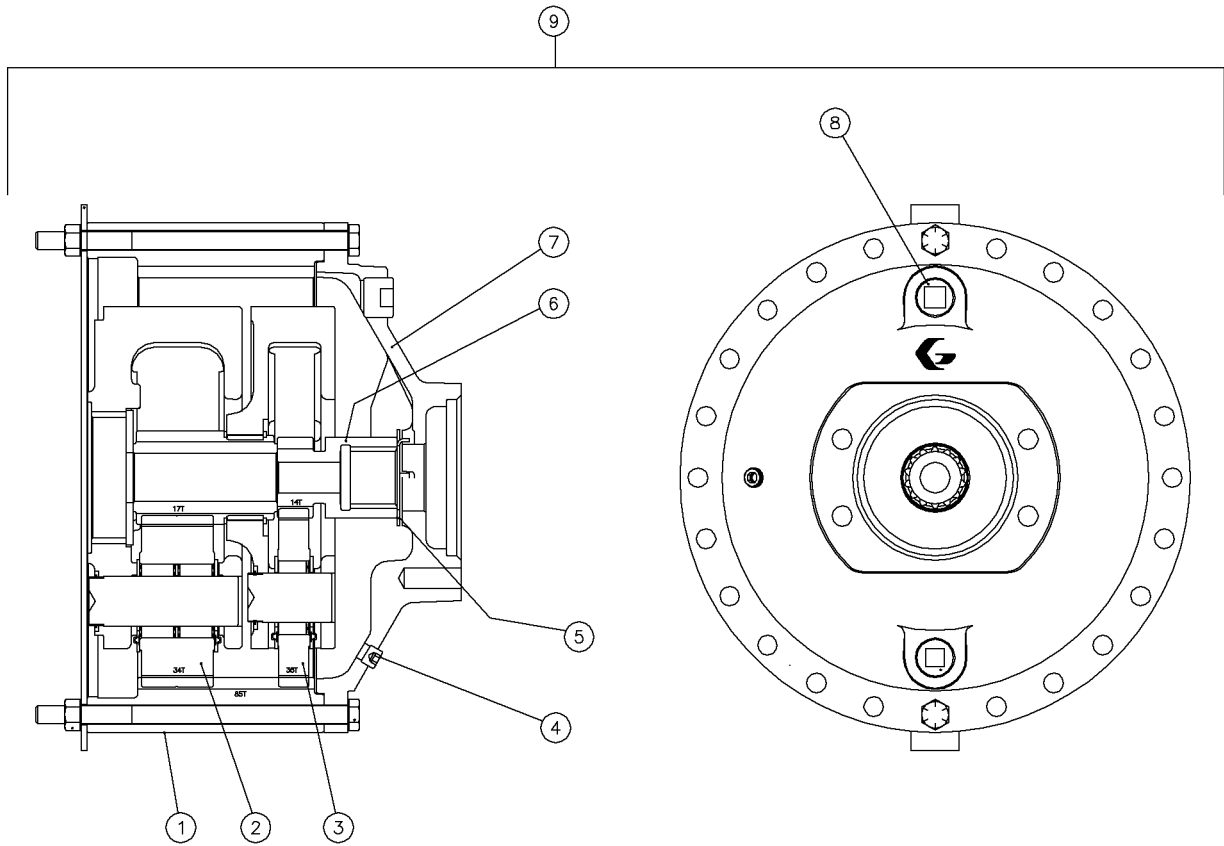

Component-Gearbox Fig 12-41

REF. NO.	*	PART NO.	DESCRIPTION	QTY.	REMARKS
		Revision Date	June, 2002		Addition Of Figure To Manual
1		296263418	GEAR RING	1	
2		296251343	SEC. CARRIER ASSEMBLY	1	
3		296263417	ASSY-PRI CARRIER	1	
4		296263416	PLUG-PIPE	1	
5		131488021	THRUST WASHER	1	
6		296263415	GEAR-PRI SUN	1	
7		296263414	COVER	1	
8		231393049	PLUG - MAGNETIC	1	
9		296262570	GEARBOX - AUBURN HUB KIT MODEL 8	1	Inc All Items In Figure

Component-Hyd Cylinder Fig 12-42

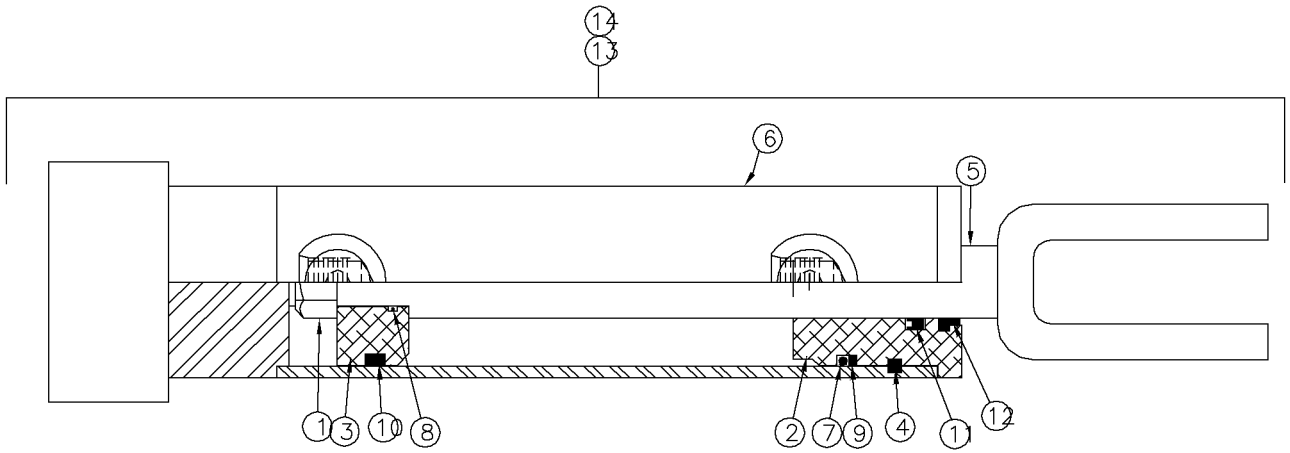

Component-Hyd Cylinder Fig 12-42

REF. NO.	*	PART NO.	DESCRIPTION	QTY.	REMARKS
		Revision Date	June, 2002		Addition Of Figure To Manual
1		230958009	NUT	1	
2		296263420	HEAD	1	
3		296263421	PISTON	1	
4		296263422	RETAINING RING	1	
5		296263423	SHAFT	1	
6		296263424	BARREL WITH PORTS	1	
7		NSS	O-RING	1	
8		NSS	O-RING	1	
9		NSS	BACKUP	1	
10		NSS	PSP SEAL	1	
11		NSS	ROD SEAL	1	
12		NSS	DUST SEAL	1	
13		296263425	REPAIR KIT	1	Inc Ref No's 7-12
14		296262569	HYD CYL - 1.75 X .75 X 4 STROKE	1	Inc All Items In Figure
			NSS- Not Sold Separate		

Component-Hyd Cylinder Fig 12-43r01

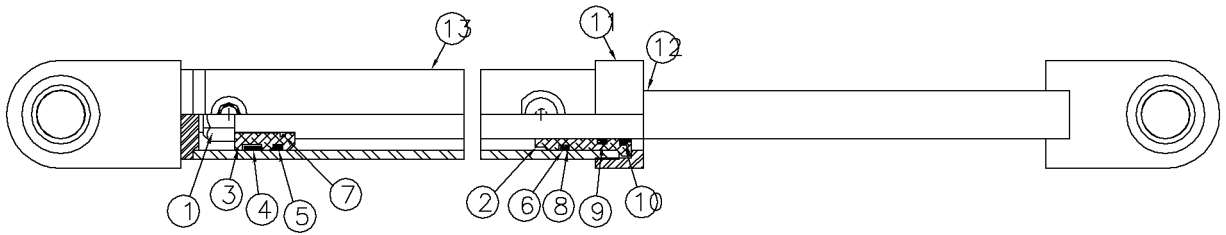

Component-Hyd Cylinder Fig 12-43r01

REF. NO.	*	PART NO.	DESCRIPTION	QTY.	REMARKS
		Revision Date	October, 2004		Update In Illustration & Parts List.
1		NSS	NUT	1	
2		NSS	HEAD	1	
3		NSS	PISTON	1	
4		NSS	WEAR RING	1	
5		NSS	PSP SEAL	1	
6		NSS	O-RING	1	
7		NSS	O-RING	1	
8		NSS	BACK UP	1	
9		NSS	ROD SEAL	1	
10		NSS	DUST SEAL	1	
11		NSS	COLLAR	1	
12		296271121	SHAFT WITH CLEVIS	1	
		296271122	REPAIR KIT		Inc Ref 4-10

Component-Hyd Cylinder Fig 12-43

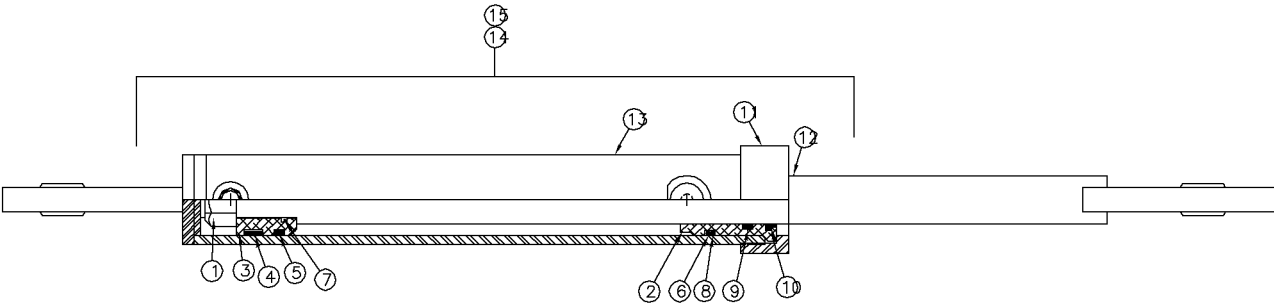

Component-Hyd Cylinder Fig 12-43

REF. NO.	*	PART NO.	DESCRIPTION	QTY.	REMARKS
		Revision Date	June, 2002		Addition Of Figure To Manual
1		296263824	NUT	1	
2		296263426	HEAD	1	
3		296263427	PISTON	1	
4		NSS	WEAR RING	1	
5		NSS	PSP SEAL	1	
6		NSS	O-RING	1	
7		NSS	O-RING	1	
8		NSS	BACKUP	1	
9		NSS	ROD SEAL	1	
10		NSS	DUST SEAL	1	
11		296263428	COLLAR	1	
12		296263429	SHAFT WITH CLEVIS	1	
13		296263430	BARREL WITH CLEVIS & PORTS	1	
14		296263431	REPAIR KIT	1	Inc Ref No's 4-10
15		296265251	HYD. CYL.-1.5 " X 8" STR	1	Inc All Items In Figure
			NSS- Not Sold Separate		

Component-Hyd Valve-Scissor Vise Lift Fig 12-44

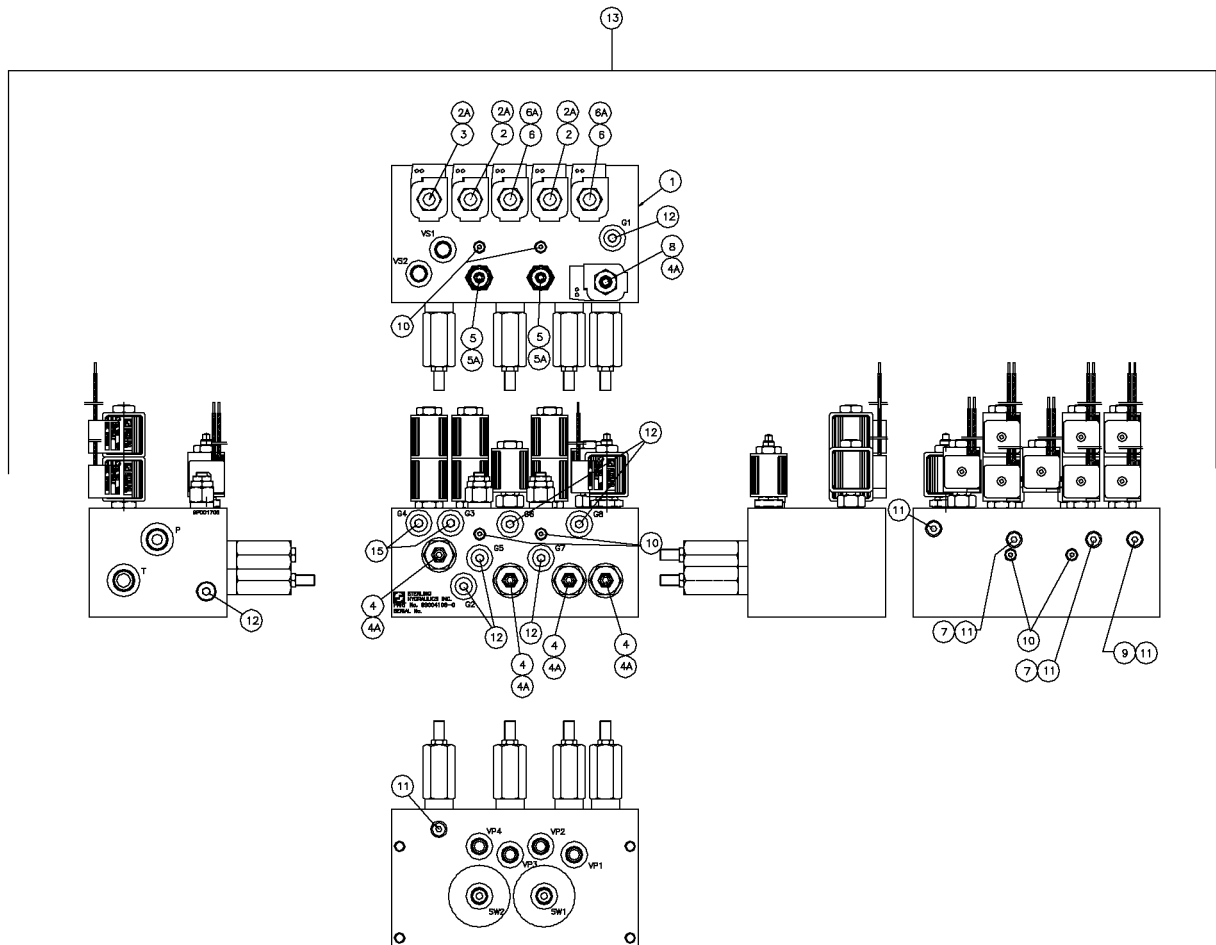

Component-Hyd Valve-Scissor Vise Lift Fig 12-44

REF. NO.	*	PART NO.	DESCRIPTION	QTY.	REMARKS
		Revision Date	June, 2002		Addition Of Figure To Manual
1		NSS	BLOCK	1	
2		255077009	SOLENIOD-3/4 WAY VALVE	2	
2A		255077007	SEAL KIT	3	
2B		255077011	COIL	2	
3		296263437	SOLENIOD-3/4 WAY VALVE	1	
4		296263438	RELIEF VALVE	4	
4A		277838013	SEAL KIT	5	
5		255076019	LOAD CONTROL VALVE	2	
5A		255076021	SEAL KIT	2	
6		296263439	SOLENIOD-2/2 WAY VALVE	2	
6A		500767005	SEAL KIT	2	
7		296263440	ORIFICE PLUG (1/16 NPTF 0.5MM W/ SCREEN	2	
8		296263441	SOLENIOD-2/2 WAY VALVE	1	
9		296263442	ORIFICE PLUG (M8 W/.1.20MM	1	
10		296253472	PLUG-ZERO LEAK HEX	6	
11		255268009	PLUG-ZERO LEAK HEX	5	
12		296253473	PLUG-ZERO LEAK HEX	9	
13		296265317	HYDRAULIC VALVE-SIZZOR VISE-LIFT	1	Inc All Items In Figure
			NSS- Not sold Separate		

Component-Valve Scissor Vise Fig 12-45r01

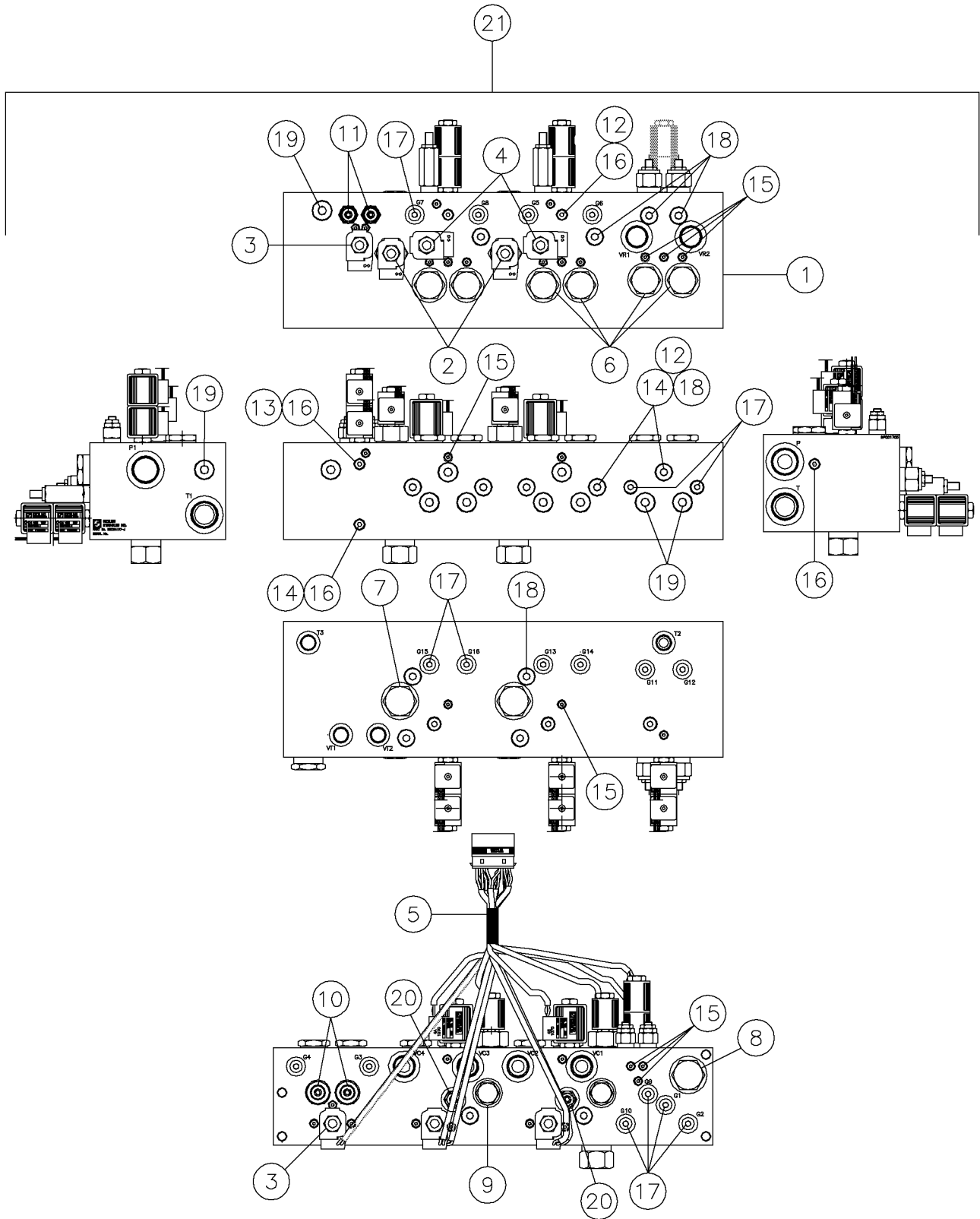

Component-Valve Scissor Vise Fig 12-45r01

REF. NO.	*	PART NO.	DESCRIPTION	QTY.	REMARKS
		Revision Date	October, 2004		Update In Illustration & Parts List.
1		NSS	BLOCK	1	Not Sold Separately
2		296263443	2/2 WAY SOLENOID VALVE	2	
		212950009	REPAIR KIT-VALVE	2	
3		255077009	3/4 WAY SOLENOID SPOOL VALVE	4	
		255077007	SEAL KIT	4	
4		296263445	PROPORTIONAL RELIEF VALVE	2	
		500767005	SEAL KIT	2	
5		296278019	WIRE HARNESS - 24 PIN	1	
6		296263446	DIVERTER VALVE	6	
		125083021	SEAL KIT	6	
7		296263447	DIVERTER VALVE	2	
		296263454	SEAL KIT	2	
8		296263448	CHECK VALVE	1	
		296263455	SEAL KIT	1	
9		258794009	CHECK VALVE	2	
		255075041	SEAL KIT	2	
10		296263442	LOAD CONTROL VALVE	2	
		296263259	SEAL KIT	2	
11		296278015	LOAD CONTROL VALVE	2	
		255076021	SEAL KIT	2	
12		296263450	ORIFICE PLUG - M8 W/ .040	3	
13		296263457	ORIFICE PLUG - M8 W/ .047	1	
14		296263451	ORIFICE PLUG - M12 W/ .120	1	
15		277838015	PLUG - #2 EPCO	31	
16		296278016	PLUG - #4 EPCO	5	
17		98108013	PLUG-7/16-ZOUNF SOCKHD	21	
18		296278017	PLUG - #8 EPCO	15	
19		296278018	PLUG - #10 EPCO	11	
20		296253469	RELIEF VALVE	2	
		258794019	SEAL KIT	2	
21		296265316	HYD VALVE - SCISSORS VISE - CLAMP	1	Included All Items In Figure

Component-Valve Scissor Vise Fig 12-45

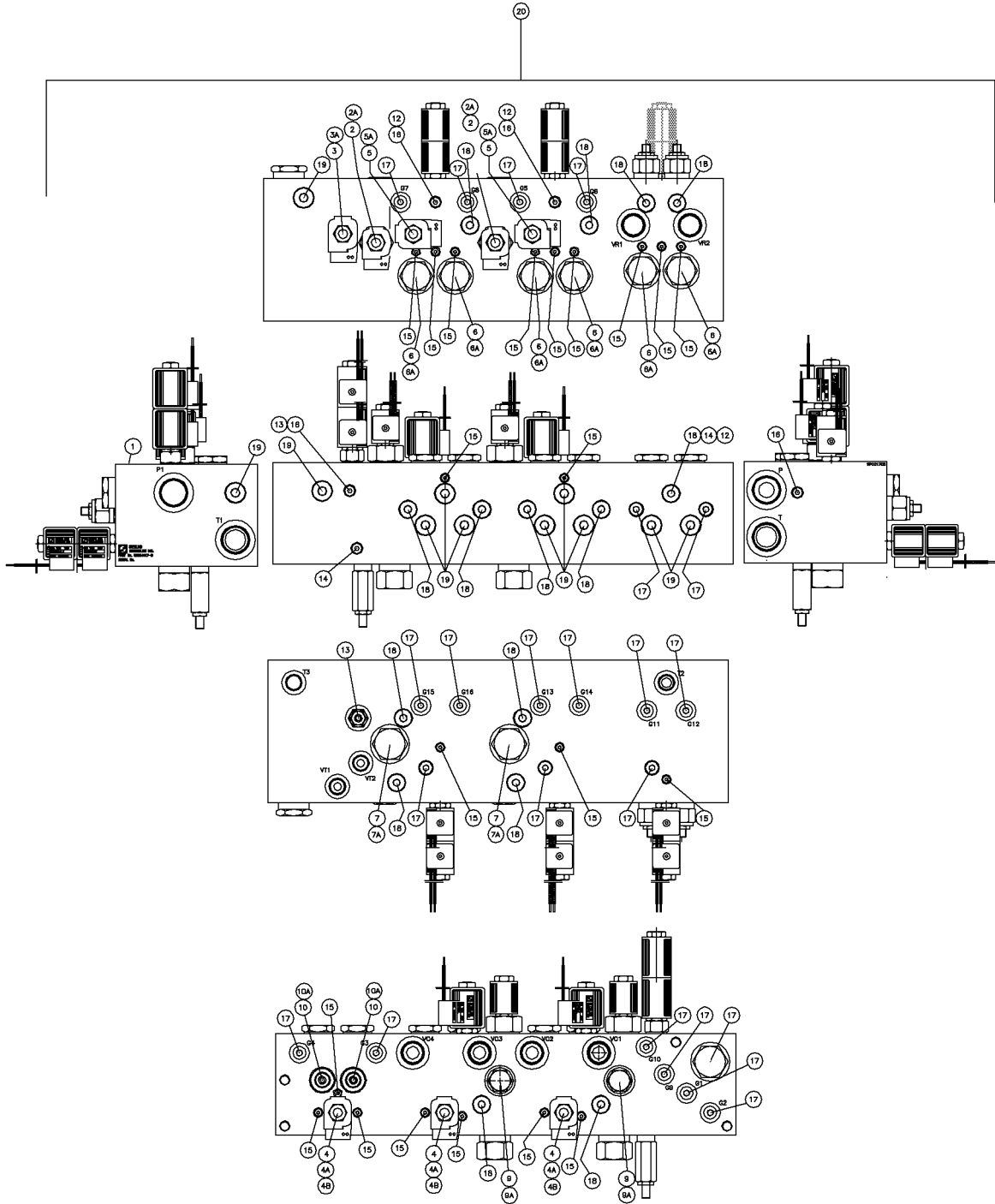

Component-Valve Scissor Vise Fig 12-45

REF. NO.	*	PART NO.	DESCRIPTION	QTY.	REMARKS
		Revision Date	June, 2002		Addition Of Figure To Manual
1		NSS	BLOCK	1	
2		296263443	VALVE-2/2 WAY SOLENOID	2	
2A		212950009	REPAIR KIT-VALVE	2	
3		296263444	VALVE-3/4 WAY SOLENOID	1	
3A		296263453	SEAL KIT	1	
4		255077009	VALVE-3/4 WAY SOLENOID SPOOL VALVE	3	
4A		255077007	SEAL KIT	3	
4B		255077011	COIL	3	
5		296263445	PROPORTIONAL RELIEF VALVE	2	
5A		500767005	SEAL KIT	2	
6		296263446	DIVERTER VALVE	6	
6A		125083021	SEAL KIT	6	
7		296263447	DIVERTER VALVE	2	
7A		296263454	SEAL KIT	2	
8		296263448	CHECK VALVE	1	
8A		296263455	SEAL KIT	1	
9		296263449	CHECK VALVE	2	
9A		255075041	SEAL KIT	2	
10		296263457	LOAD CONTROL VALVE	2	
10A		296263259	SEAL KIT	2	
11		296253469	RELIEF VALVE	1	
11A		296263456	SEAL KIT	1	
12		296263450	ORIFICE PLUG (M8 W/.040 ORIFICE	3	
13		296263442	ORIFICE PLUG (M8 W/.047 ORIFICE	1	
14		296263451	ORIFICE PLUG (M12 W/.120 ORIFICE	1	
15		296253472	ZERO-LEAK HOLLOW HEX PLUG	21	
16		255268009	#4 ZERO-LEAK HOLLOW HEX PLUG	5	
17		296253473	ZERO-LEAK HOLLOW HEX PLUG	21	
18		296253474	ZERO-LEAK HOLLOW HEX PLUG	15	
19		296263452	ZERO-LEAK HOLLOW HEX PLUG	11	
20		296265316	HYD VALVE-SIZZOR VISE-CLAMP	1	Inc All Items In Figure
			NSS-Not Sold Separately		

Component-Hyd Cylinder Fig 12-46r01

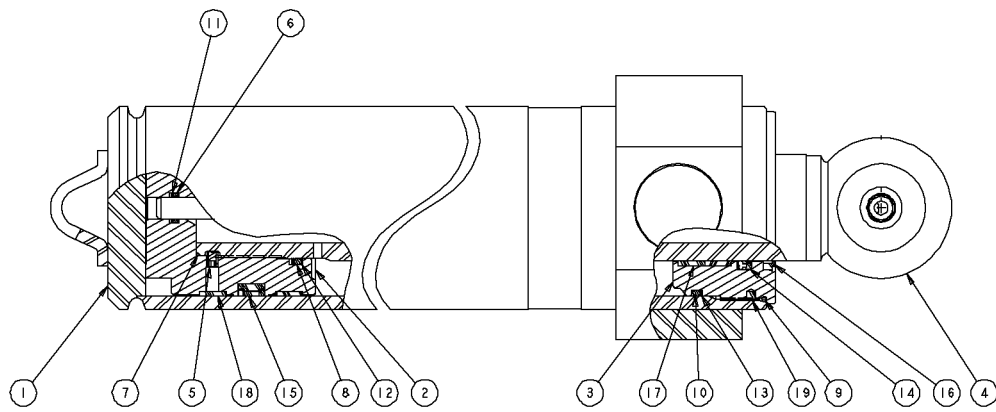

Component-Hyd Cylinder Fig 12-46r01

REF. NO.	*	PART NO.	DESCRIPTION	QTY.	REMARKS
		Revision Date	October, 2004		Update In Illustration & Parts List.
1		296271127	TUBE WELDMENT	1	
2		296271126	PISTON	1	
3		296271125	HEAD GLAND	1	
4		296263434	ROD WELDMENT	1	
5		296263435	.313-18 UNC X .44 LG SET SCREW	3	
6		NSS	O-RING	1	
7		NSS	O-RING	1	
8		NSS	O-RING	1	
9		NSS	O-RING	1	
10		NSS	O-RING	1	
11		NSS	BACKUP RING	2	
12		NSS	BACKUP RING	2	
13		NSS	BACKUP RING-DYNAMIC	1	
14		NSS	DZR SEAL	1	
15		NSS	CAPPED T-SEAL	1	
16		NSS	HD ROD WIPER-SEAL OD	1	
17		NSS	PRECISION WEARBAND	2	
18		NSS	PRECISION WEARBAND	2	
19		NSS	LOCKING INSERT	2	
		296271128	SEAL KIT		Inc Ref 6-19
		296267957	CYLINDER-5"X12.75"- 3.00"ROD(TRUNNION MNT		Inc All Items In Figure
			NSS-Not Sols Separate		

Component-Hyd Cylinder Fig 12-46

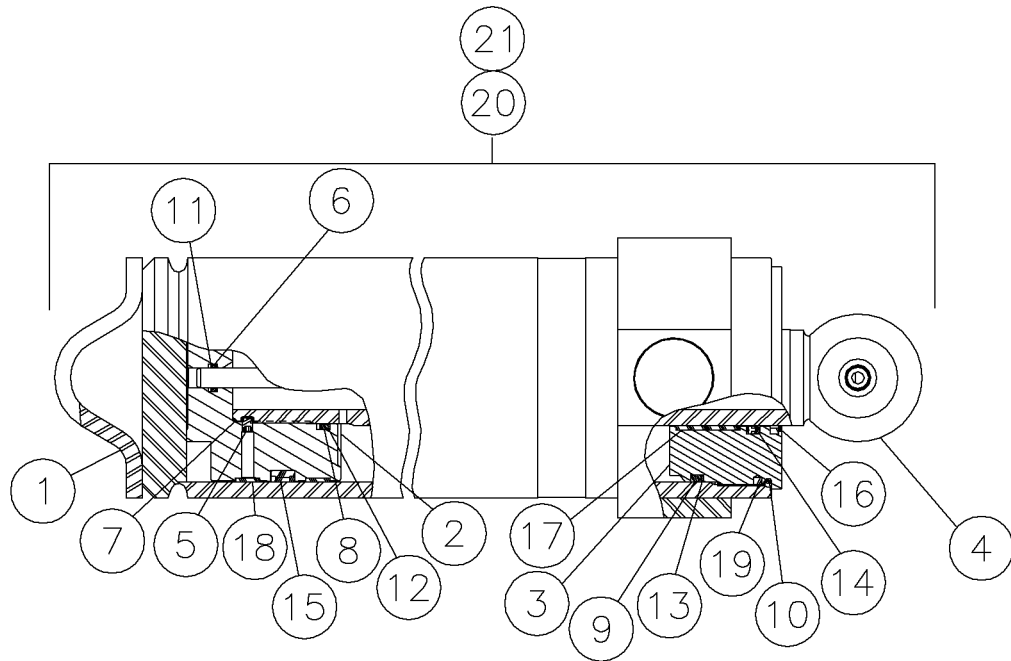

Component-Hyd Cylinder Fig 12-46

REF. NO.	*	PART NO.	DESCRIPTION	QTY.	REMARKS
		Revision Date	June, 2002		Addition Of Figure To Manual
1		296262432	TUBE WELDMENT	1	
2		296263433	PISTON	1	
3		605993001	HEAD GLAND	1	
4		296263434	ROD WELDMENT	1	
5		296263435	SCREW-.313-18 UNCX.44 LG SET SCREW	3	
6		NSS	O-RING	1	
7		NSS	O-RING	1	
8		NSS	O-RING	1	
9		NSS	O-RING	1	
10		NSS	O-RING	1	
11		NSS	BACKUP RING	2	
12		NSS	BACKUP RING	2	
13		NSS	BACKUP RING	1	
14		NSS	DEEP Z-SEAL WITH ROD BACKUP	1	
15		NSS	CAPPED T-SEAL	1	
16		NSS	HD ROD WIPER, SEAL OD	1	
17		NSS	PRECISION WEARBAND	2	
18		NSS	PRECISION WERABAND	2	
19		NSS	LOCKING INSERT	2	
20		296263436	SEAL KIT	1	Inc Ref No's No's 6-19
21		296262568	CYLINDER-6.50 X 12.75 3.00 HYD. CYLINDER	1	Inc All Items In Figure
			NSS- Not Sold Separate		

Component-Hyd Motor-Vise Fig 12-47

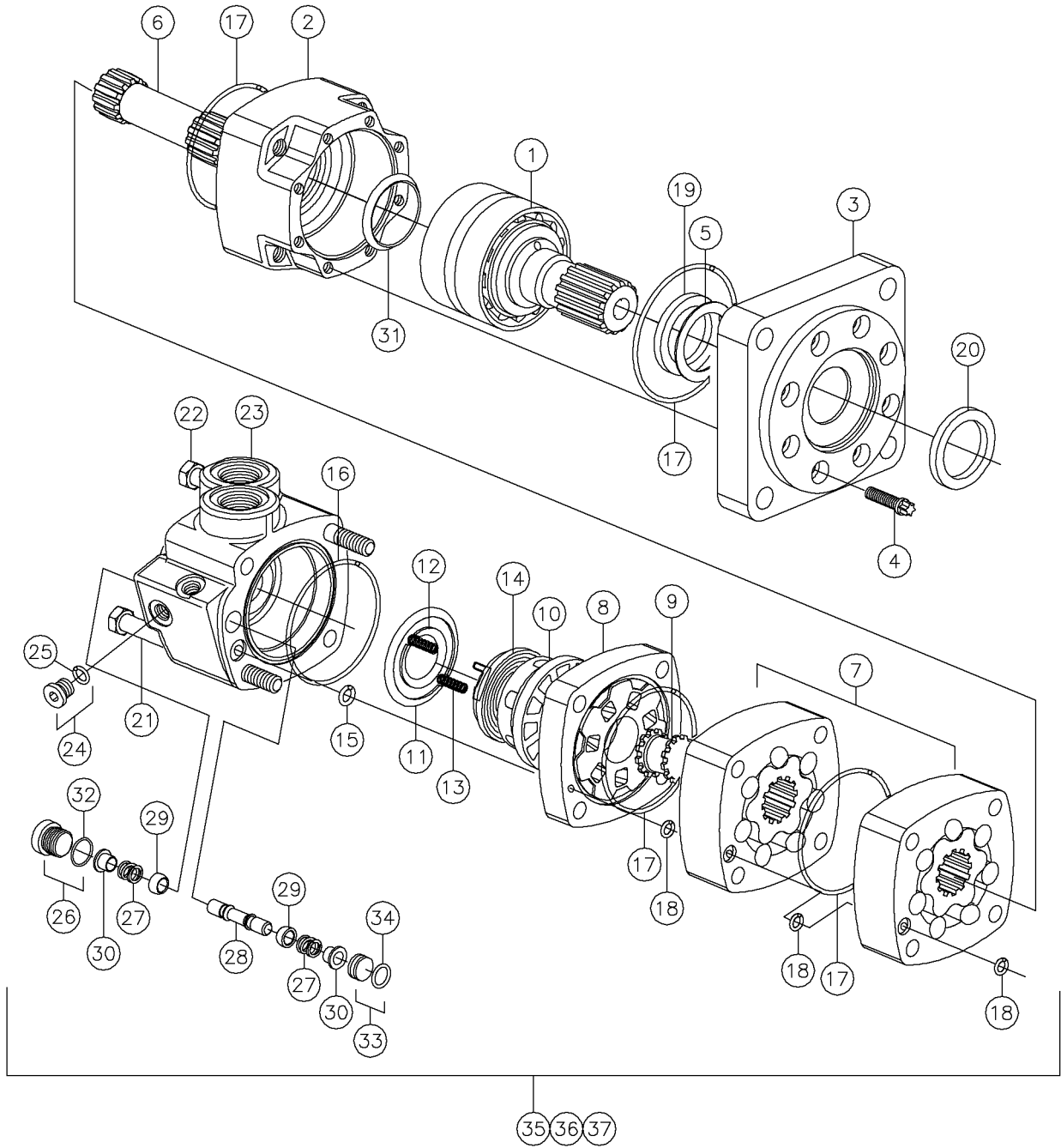

Component-Hyd Motor-Vise Fig 12-47

REF. NO.	*	PART NO.	DESCRIPTION	QTY.	REMARKS
		Revision	June, 2002		Addition Of Figure To Manual
1		296265528	SHAFT-SUB ASSEMBLY	1	
2		296265529	HOUSING-BEARING	1	
3		296265530	RETAINER-FRONT	1	
4		296265531	SCREW-CAP	8	
5		775011	WASHER-BACKUP 6943	1	
6		296265532	DRIVE-MAIN	1	
7		NSS	GEROLER ASS'Y	1	
8		13514019	PLATE-VALVE 8504	1	
9		13514017	DRIVE-VALVE 8510	1	
10		13514021	VALVE-8500	1	
11		775041	SEAL-OUTER FACE 6962	1	
12		775043	SEAL-FACE INNER 6961	1	
13		776041	SPRING-6203	2	
14		53853017	BALANCE RING&PINS 21316CHARLYN	1	
15		779025	SEAL-O RING 15006	1	
16		775049	SEAL-9022-7	1	
17		13514033	SEAL-3 1/2 ID	4	
18		215338009	SEAL	3	
19		53853005	SEAL-SHAFT 9057-12 CHAR-LYNN	1	
20		53853003	SEAL-DUST 9031-1 CHAR-LYNN	1	
21		296265533	SCREW	3	
22		296265534	SCREW	1	
23		296265535	HOUSING-VALVE	1	
24		209137029	PLUG ASSEMBLY	1	
25		4485011	O-RING-250003-903 (90D)	1	
26		296265536	PLUG-SUB ASSEMBLY	1	
27		209137021	SPRING	2	
28		209137025	PISTON	1	
29		257547007	POPPET	2	
30		209137019	SLEEVE-DASH POT	2	
31		776043	SEAL-FACE INNER 6993	1	
32		201666033	O-RING 250003-906	1	
33		296265537	PLUG-SUB ASSEMBLY	1	
34		296265538	O-RING-250002-012	1	
35		296265253	HYD MOTOR - 4K-38CIR-SAE C	1	Inc All Items In Figure
36		57982025	REPAIR KIT-SHAFT	1	Inc Ref No's 5,10,11,15-20,25,31,32,34
37		210117005	REPAIR KIT-HYD. MOTOR	1	Inc Ref No's 5,17,19,20,31
			NSS- Not Sold Separately		

Component-Hyd Motor Fig 12-48

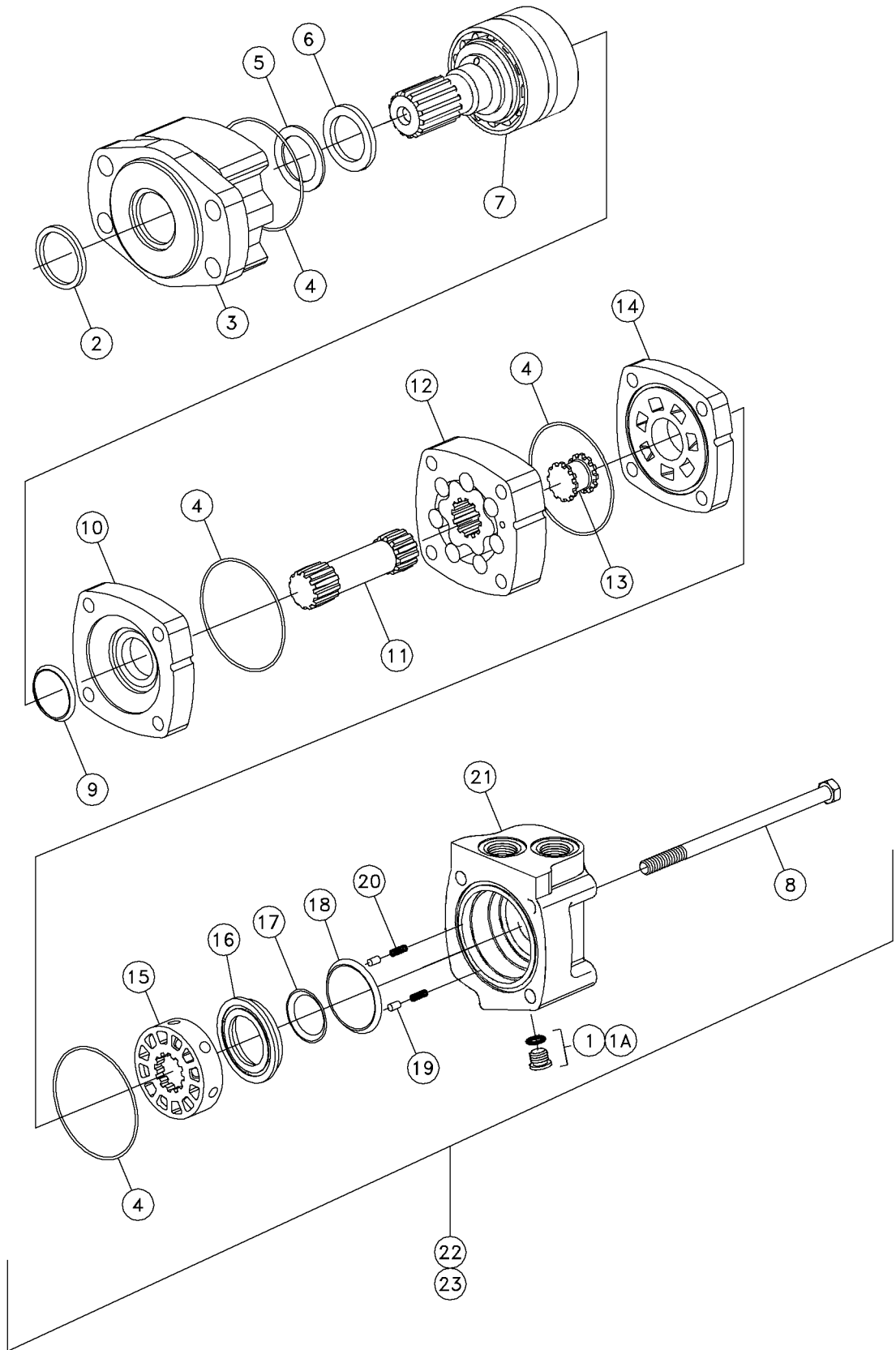

Component-Hyd Motor Fig 12-48

REF. NO.	*	PART NO.	DESCRIPTION	QTY.	REMARKS
		Revision	June, 2002		Addition of Figure To Manual
1		4485021	PLUG ASSY-9072-3	1	
1A		1185023	O-RING-250003-904	1	
2		770071	SEAL-DUST # 9121-1	1	
3		770093	HOUSING-(SAE 10 PORTS)#21564-1	1	
4		770007	SEAL-O RING 9022-6	4	
5		770009	WASHER-BACKUP 7382	1	
6		770075	SEAL-SHAFT # 9057-9	1	
7		206469001	SHAFT&BEARING KIT/1 1/4SPLINED	1	
7A		NSS	SHAFT-OUTPUT	1	
7B		NSS	CONE-BEARING	2	
7C		NSS	CUP-BEARING	2	
7D		NSS	SPACER-BEARING	1	
7E		NSS	RING-RETAINING	1	
8		296267119	SCREW, CAP	4	
9		77017	SEAL-SHAFT FACE 9050	1	
10		770079	PLATE-WEAR # 21623	1	
11		296267120	DRIVE	1	
12		NSS	GER LOER ASSY	1	
13		774011	DRIVE-VALVE 8433	1	
14		296267121	PLATE-VALVE	1	
15		770087	VALVE- # 21466	1	
16		770089	PLATE-BALANCE #8915	1	
17		770057	SEAL-FACE INNER 9049-1	1	
18		770091	SEAL-FACE OUTER #9135-2	1	
19		770037	PIN-14351	2	
20		770039	SPRING-7383	2	
21		296267117	HOUSING, BEARING	1	
22		770097	REPAIR KIT- #61258	1	Inc Ref No's 2, 4-6, 9,17, 18
23		296265252	HYD MOTOR - 2K-8CIR-4 BOLT MAG	1	Inc. All Items In Figure
			NSS-NOT SOLD SEPARATELY		

Component-Water Shut-Off Valve Fig 12-49

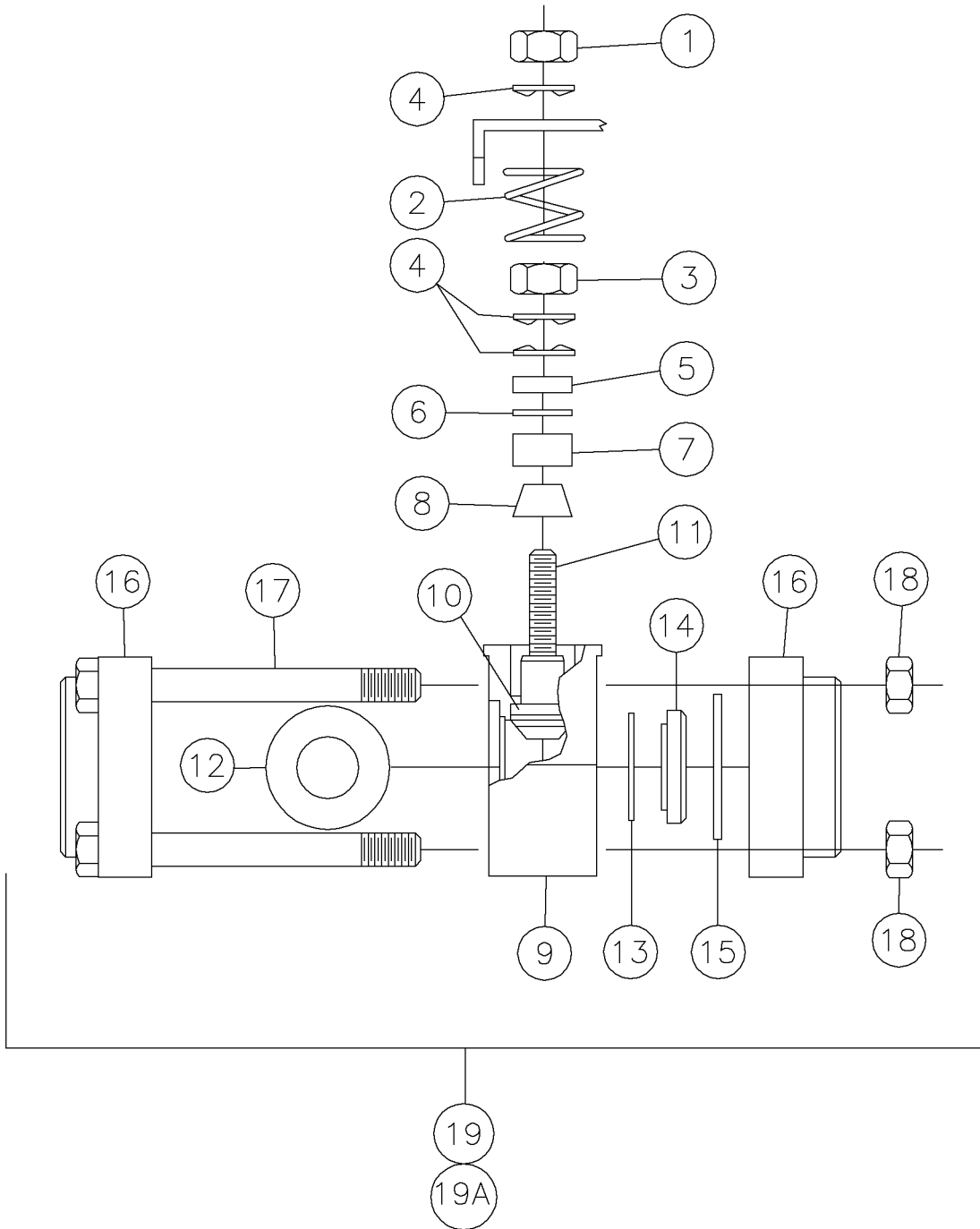

Component-Water Shut-Off Valve Fig 12-49

REF. NO.	*	PART NO.	DESCRIPTION	QTY.	REMARKS
		Revision Date	June, 2002		Add Figure
1		287053002	NUT - STEM	1	
2		287053003	SPRING - GROUNDING	1	
3		287053004	NUT - STEM	1	
4		287053005	SPRING - STEM	3	
5		287053006	GLAND	1	
6		287053007	SUPPORT - PACKING	1	
7		287053008	PACKING - TOP	1	
8		287053009	PACKING - BOTTOM	1	
9		287053010	BODY - CYLINDER	1	
10		287053011	BEARING - STEM	2	
11		287053012	STEM	1	
12		287053013	BALL	1	
13		287053014	RING - SUPPORT	2	
14		287053015	SEAT/SEAT SPRING	2	
15		287053016	O-RING	2	
16		287053017	FLANGE	2	
17		287053018	CAP - SCREW	4	
18		287053019	NUT - BODY	8	
19		287053001	VALVE - 1-1/2" BALL (2200 PSI)	1	Inc. Ref No's 1-18
19A		287053020	KIT - MAINTENANCE	1	Inc. Ref No's 4-8,10 & 14-15

Component-Hyd Cylinder Fig 12-50

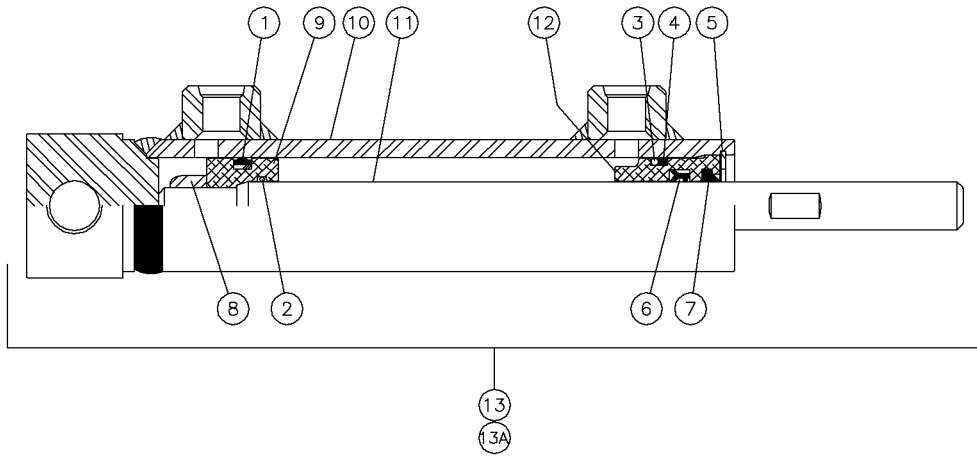

Component-Hyd Cylinder Fig 12-50

REF. NO.	*	PART NO.	DESCRIPTION	QTY.	REMARKS
1		NSS	PSP SEAL	1	
2		NSS	O'RING	1	
3		NSS	O'RING	1	
4		NSS	BACKUP RING	1	
5		NSS	INTERNAL SNAP RING	1	
6		NSS	DOUBLE LIP U-CUP	1	
7		NSS	ROD WIPER	1	
8		296254582	LOCKNUT	1	
9		296254583	PISTON	1	
10		296254584	BARREL ASSEMBLY	1	
11		296254585	ROD ASSEMBLY	1	
12		296254586	SNAP RING HEAD	1	
13		287591001	CYLINDER-1"X3 1/2"	1	Inc.all Items In Fig.
13A		296254587	SEAL KIT	1	Inc. Ref No's 1-7

Component-Hyd Cylinder Fig 12-51

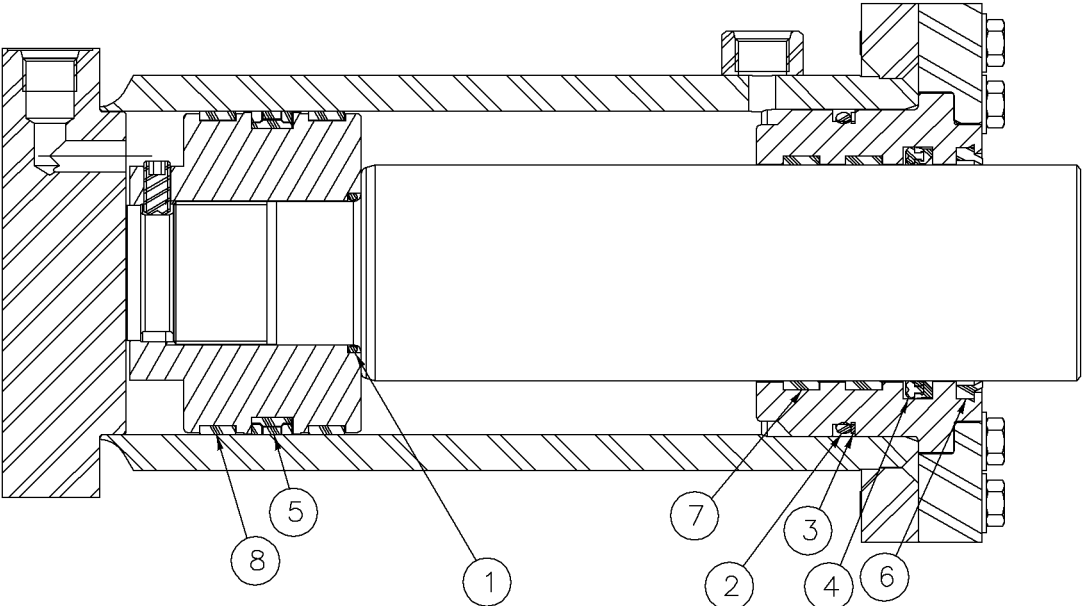

Component-Hyd Cylinder Fig 12-51

REF. NO.	*	PART NO.	DESCRIPTION	QTY.	REMARKS
		Revision Date	October, 2004		Addition To Manual
1		618381001	O-RING	1	
2		618382001	O RING	1	
3		618383001	BACKUP RING	1	
4		618384001	DEEP 2-SEAL W/ROD BACKUP	1	
5		618385001	CAPPED T-SEAL	1	
6		618386001	HD ROD WIPER, SEALED OD	1	
7		618387001	WEAR BAND	2	
8		618388001	WEAR BAND	2	
		618380001	SEAL KIT		Inc Ref 1-8
		616370001	CYLINDER- 4.50 X 5.50 X 3.00		

Component-Hyd Tension Valve Fig 12-52

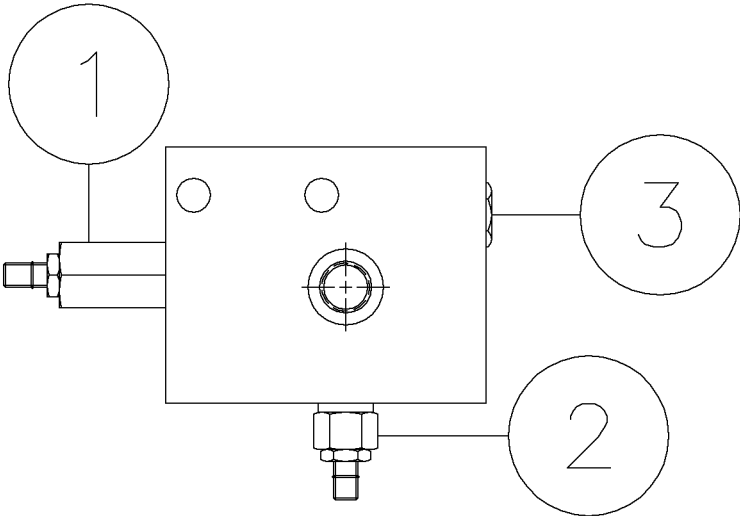

Component-Hyd Tension Valve Fig 12-52

REF. NO.	*	PART NO.	DESCRIPTION	QTY.	REMARKS
		Revision Date	October, 2004		Addition To Manual
1		296263438	RELIEF VALVE	1	
		277838013	REPAIR KIT - RELIEF VALVE	1	
2		258794007	NEEDLE VALVE	1	
		258794019	SEAL KIT	1	
3		618469001	VALVE-CHECK	1	
		296263261	SEAL KIT	1	
		613619001	TENSION VALVE FV5333-ADJ		Inc All Items In Figure

Diagram-Hyd Location-Crane Base Lift Fig 13-1r02

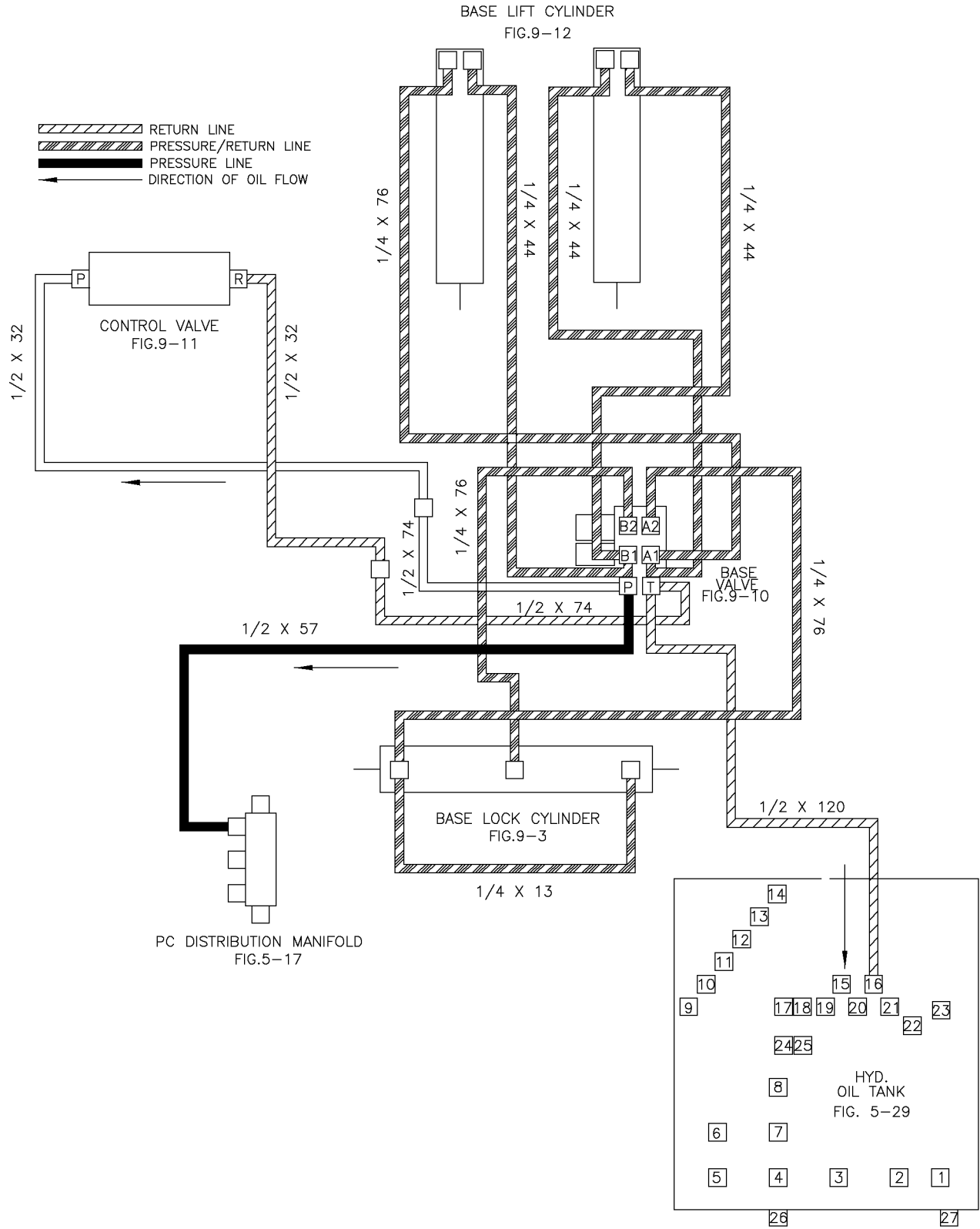

Diagram-Hyd Location-Crane Base Lift Fig 13-1r02

REF. NO.	*	PART NO.	DESCRIPTION	QTY.	REMARKS
		Revision Date	October, 2004		Update In Illustration.

Diagram-Hyd Location-Crane Base Lift Fig 13-1r01

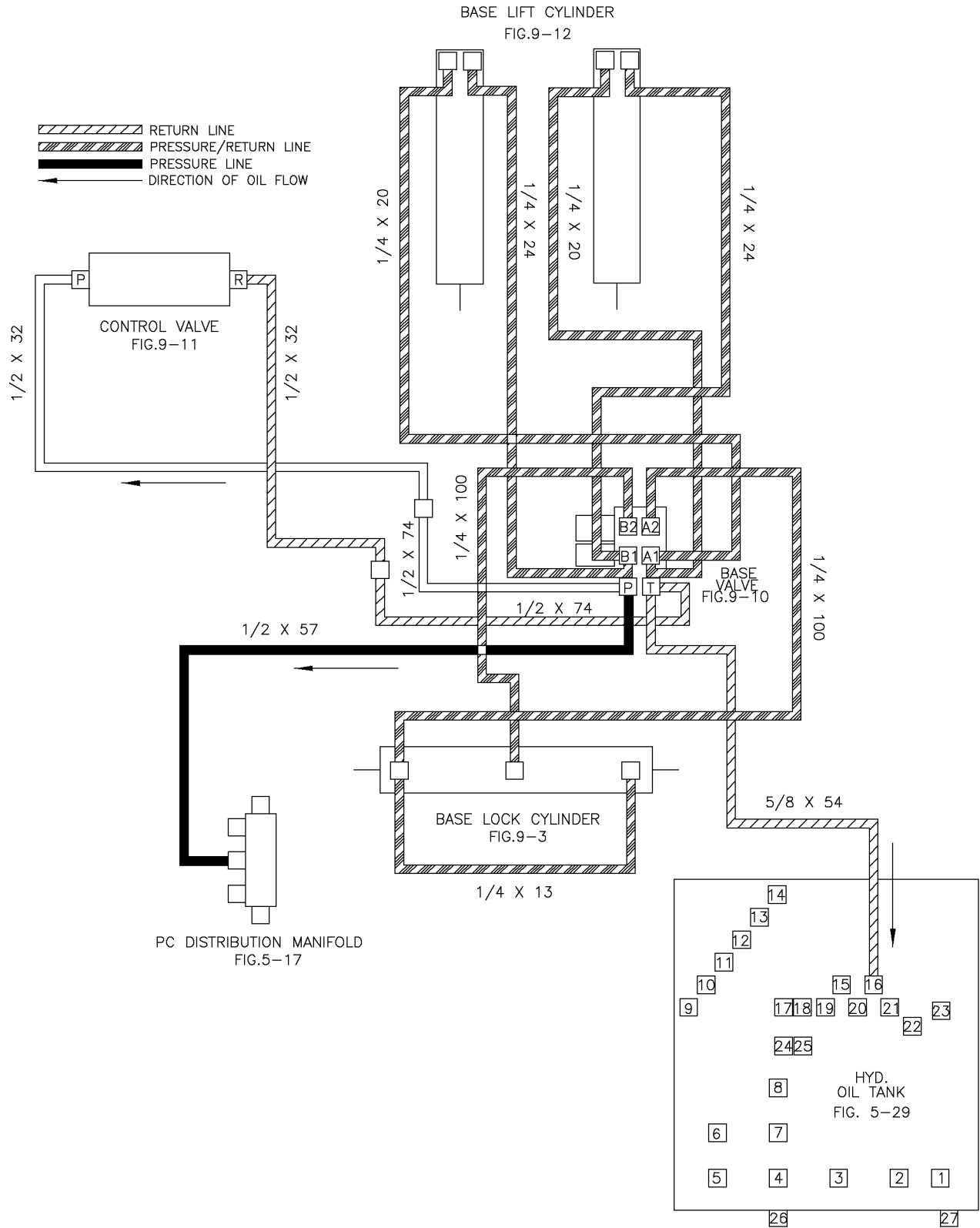

Diagram-Hyd Location-Crane Base Lift Fig 13-1r01

REF. NO.	*	PART NO.	DESCRIPTION	QTY.	REMARKS
		Revision Date	June, 2002		Update In Illustration.

Diagram-Hyd Location-Crane Base Lift Fig 13-1

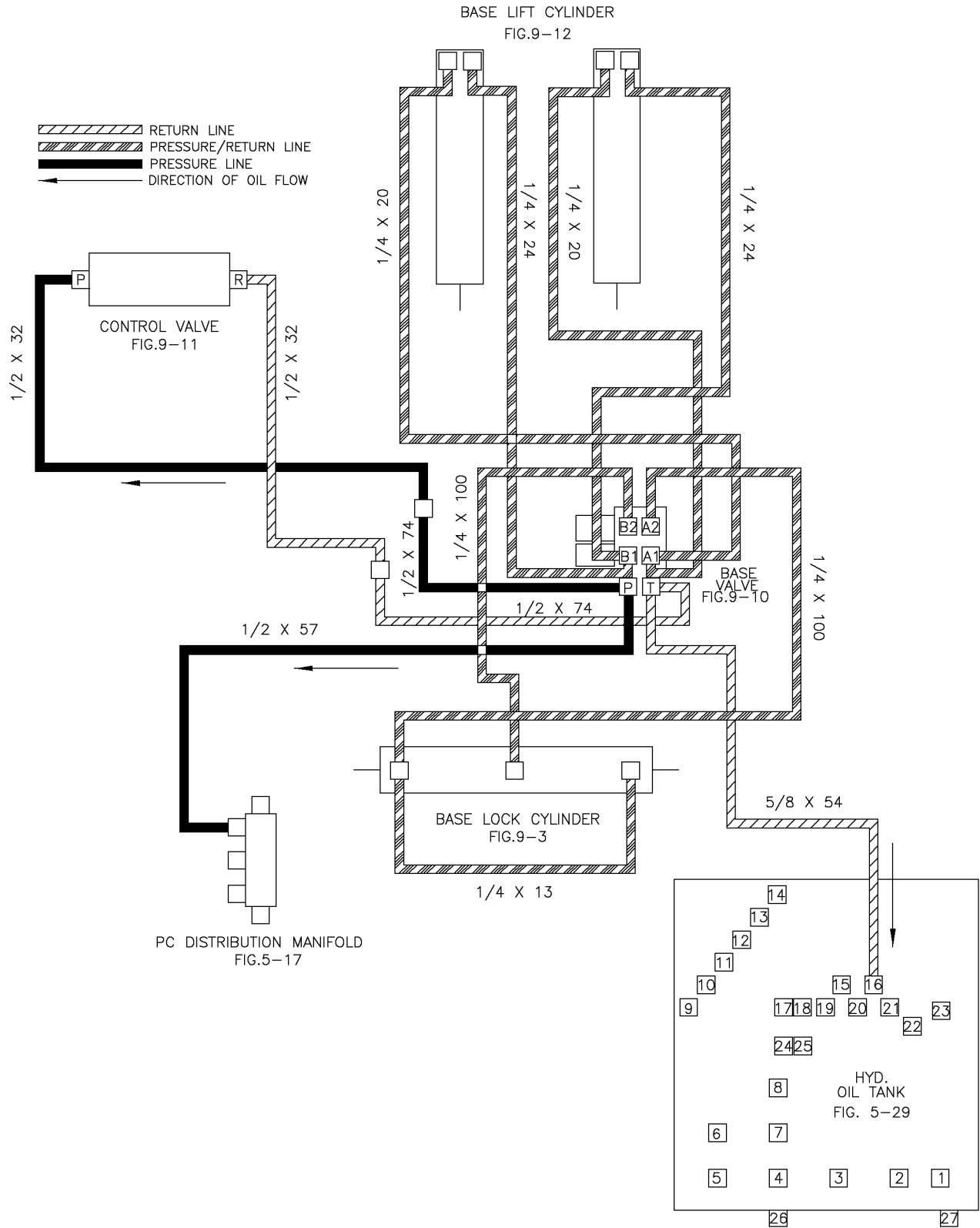

Diagram-Hyd Location-Crane Base Lift Fig 13-1

REF. NO.	*	PART NO.	DESCRIPTION	QTY.	REMARKS

Diagram-Hyd Location-Ground Drive/Pullback Pump Fig 13-2r02

REF. NO.	*	PART NO.	DESCRIPTION	QTY.	REMARKS
		Revision Date	October, 2004		Update In Illustration.

Diagram-Hyd Location-Ground Drive/Pullback Pump Fig 13-2r01

REF. NO.	*	PART NO.	DESCRIPTION	QTY.	REMARKS
		Revision Date	June, 2002		Update In Illustration.

Diagram-Hyd Location-Ground Drive/Pullback Pump Fig 13-2

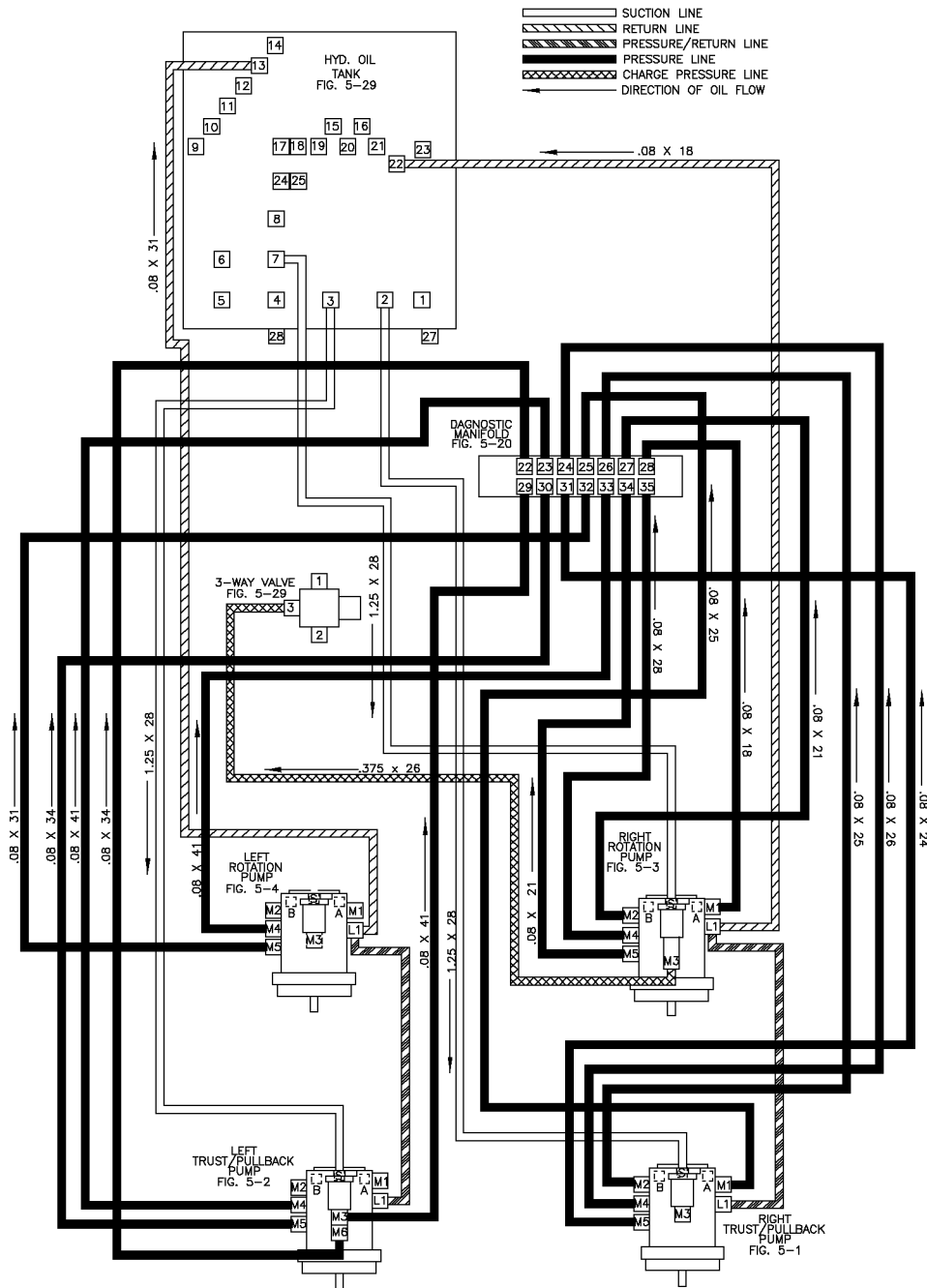

Diagram-Hyd Location-Ground Drive/Pullback Pump Fig 13-2

REF. NO.	*	PART NO.	DESCRIPTION	QTY.	REMARKS

Diagram-Hyd Location-Thrust/Pullback Motors Fig 13-3r01

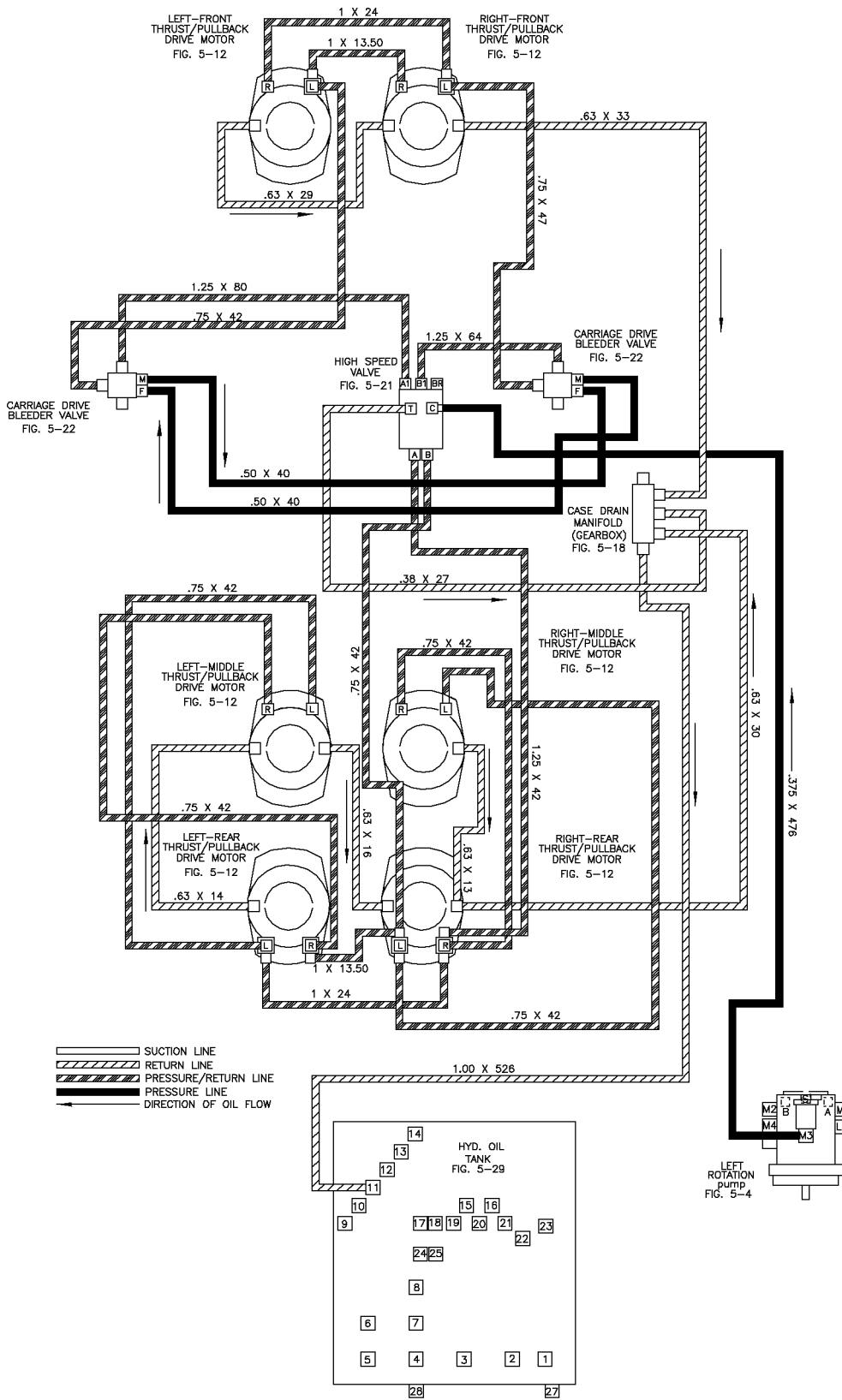

Diagram-Hyd Location-Thrust/Pullback Motors Fig 13-3r01

REF. NO.	*	PART NO.	DESCRIPTION	QTY.	REMARKS
		Revision Date	October, 2004		Update In Illustration.

Diagram-Hyd Location-Thrust/Pullback Motors Fig 13-3

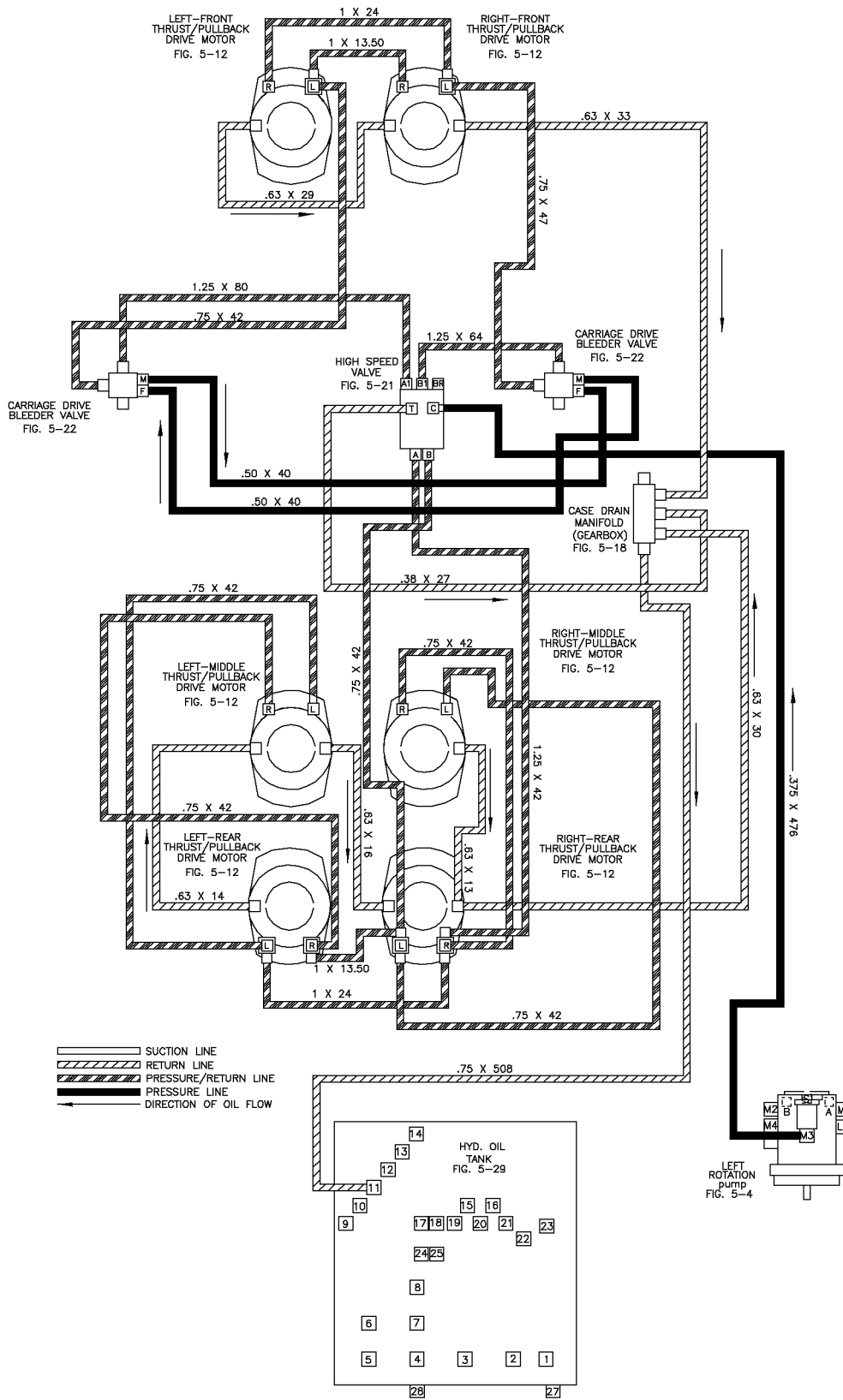

Diagram-Hyd Location-Thrust/Pullback Motors Fig 13-3

REF. NO.	*	PART NO.	DESCRIPTION	QTY.	REMARKS

Diagram-Hyd Location-Rotation Gearbox Fig 13-4

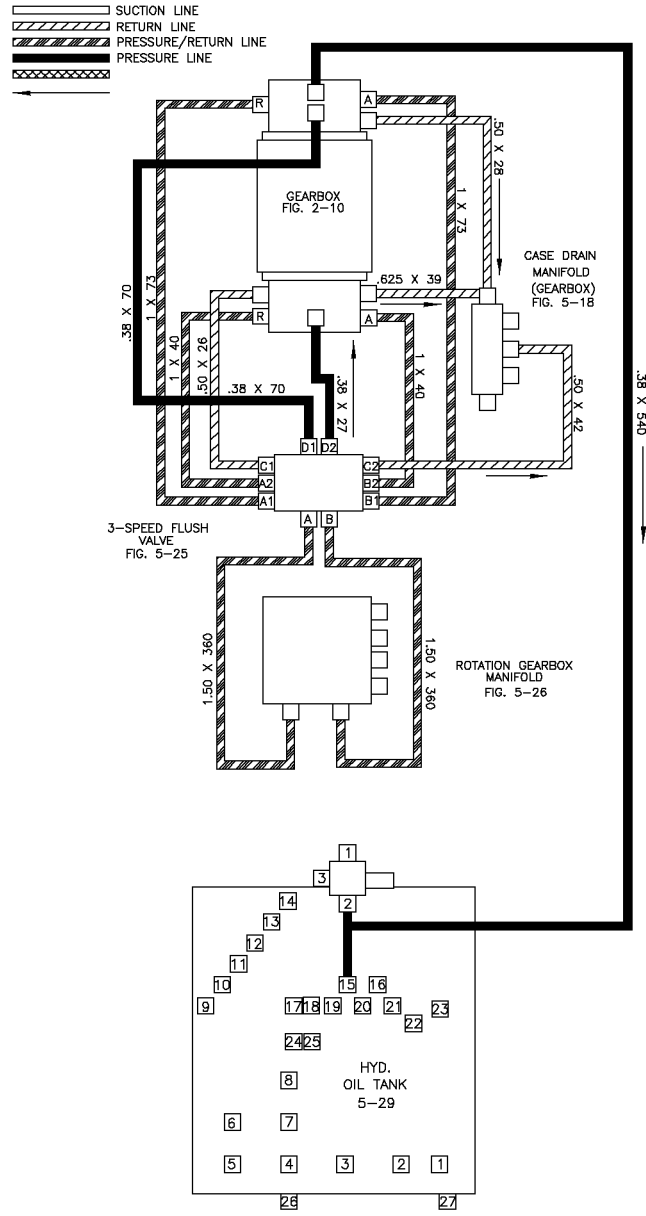

Diagram-Hyd Location-Rotation Gearbox Fig 13-4

REF. NO.	*	PART NO.	DESCRIPTION	QTY.	REMARKS

Diagram-Hyd Location-Ground Drive Fig 13-5r01

REF. NO.	*	PART NO.	DESCRIPTION	QTY.	REMARKS
		Revision Date	June, 2002		Update In Illustration.

Diagram-Hyd Location-Ground Drive Fig 13-5

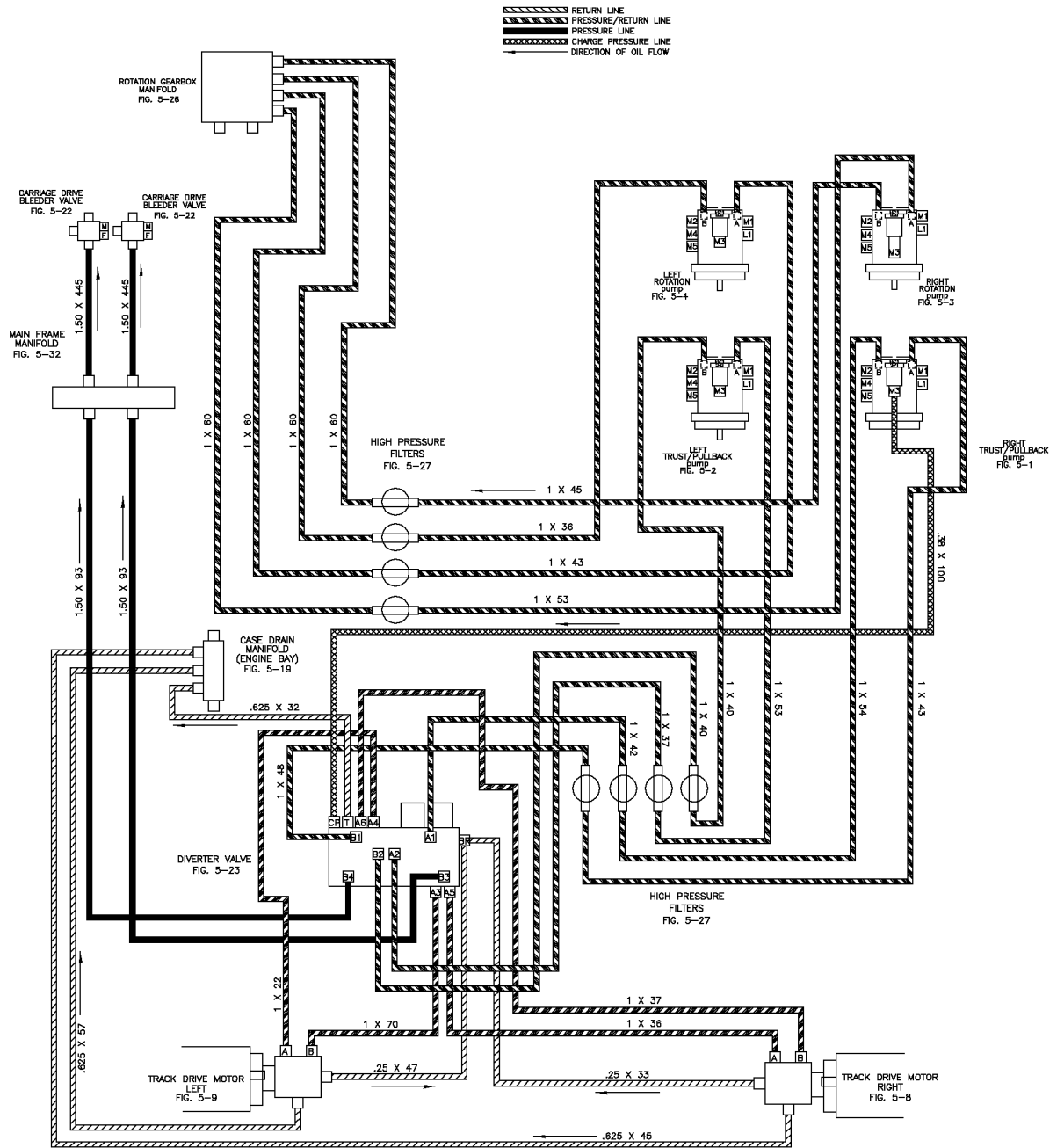

Diagram-Hyd Location-Ground Drive Fig 13-5

REF. NO.	*	PART NO.	DESCRIPTION	QTY.	REMARKS

Diagram Hyd Location-Catwalk/Handrail Fig 13-6r01

REF. NO.	*	PART NO.	DESCRIPTION	QTY.	REMARKS
		Revision Date	June, 2002		Updated Figure

Diagram Hyd Location-Catwalk/Handrail Fig 13-6

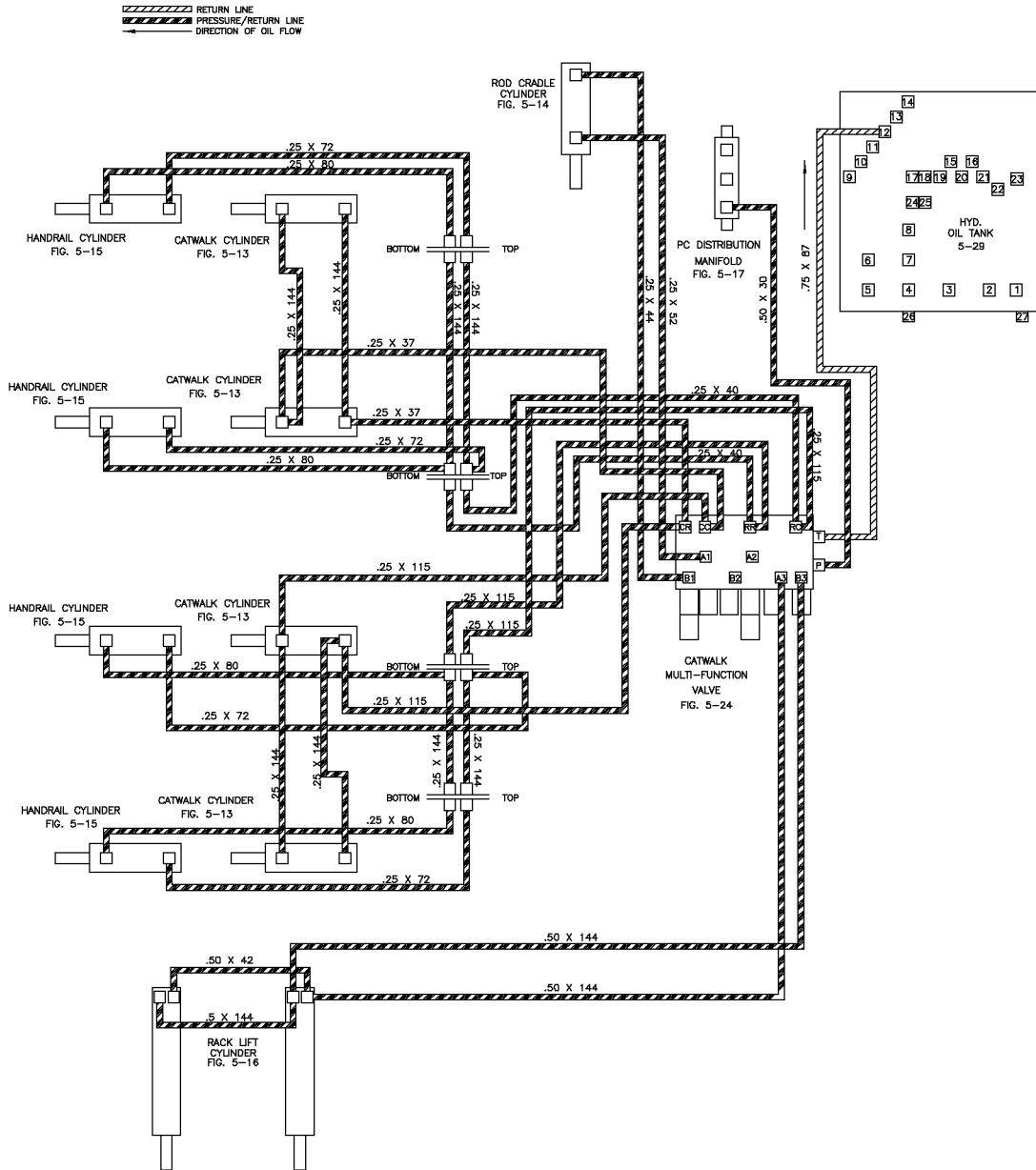

Diagram Hyd Location-Catwalk/Handrail Fig 13-6

REF. NO.	*	PART NO.	DESCRIPTION	QTY.	REMARKS

Diagram Hyd Location-Fan Motor Fig 13-7r01

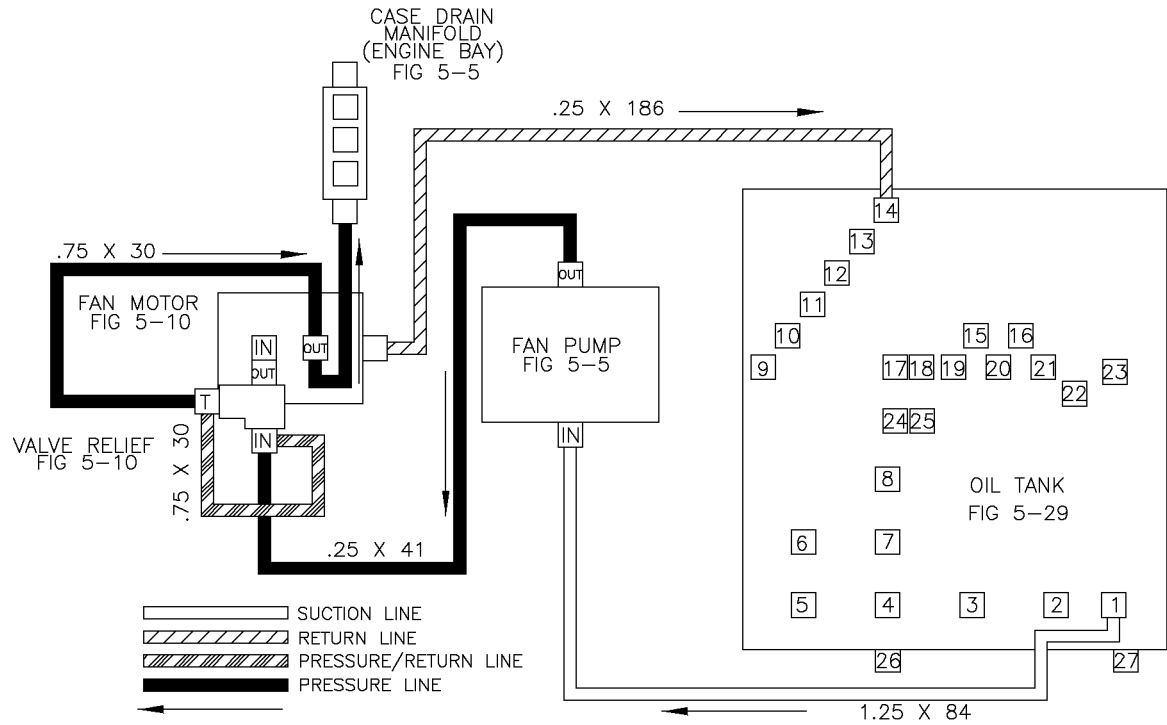

Diagram Hyd Location-Fan Motor Fig 13-7r01

REF. NO.	*	PART NO.	DESCRIPTION	QTY.	REMARKS
		Revision Date	June, 2002		Updated Illustration

Diagram Hyd Location-Fan Motor Fig 13-7

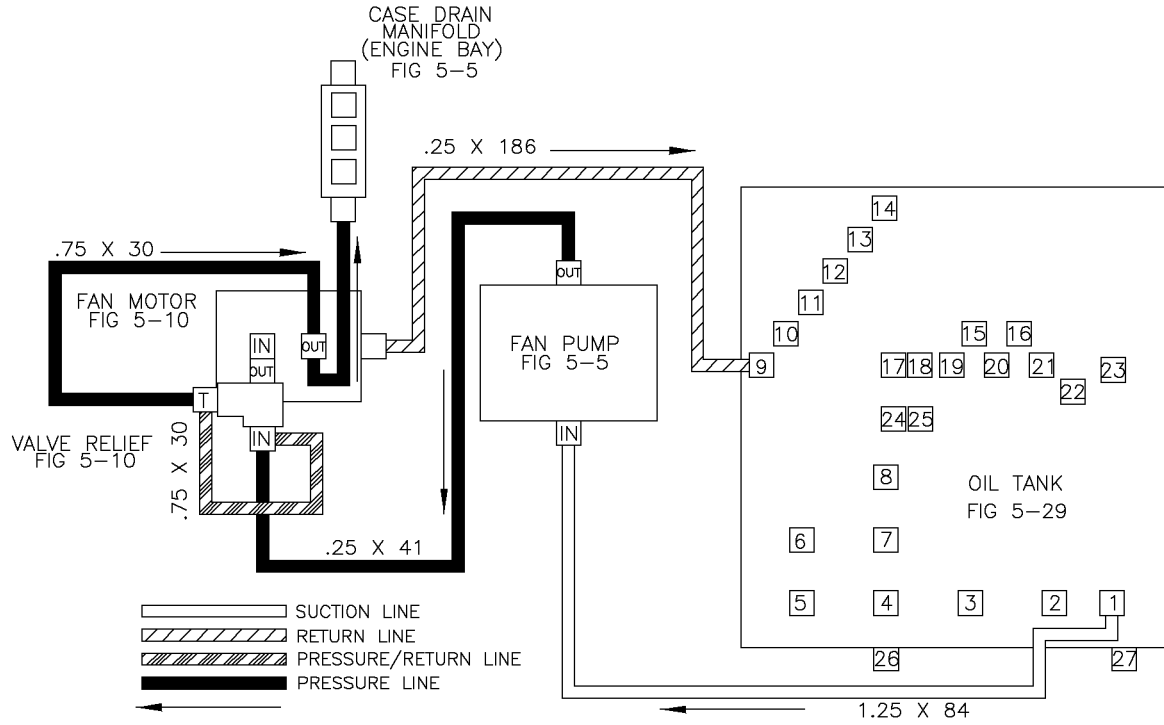

Diagram Hyd Location-Fan Motor Fig 13-7

REF. NO.	*	PART NO.	DESCRIPTION	QTY.	REMARKS

Diagram-Hyd Location Vise Rear Fig 13-8r01

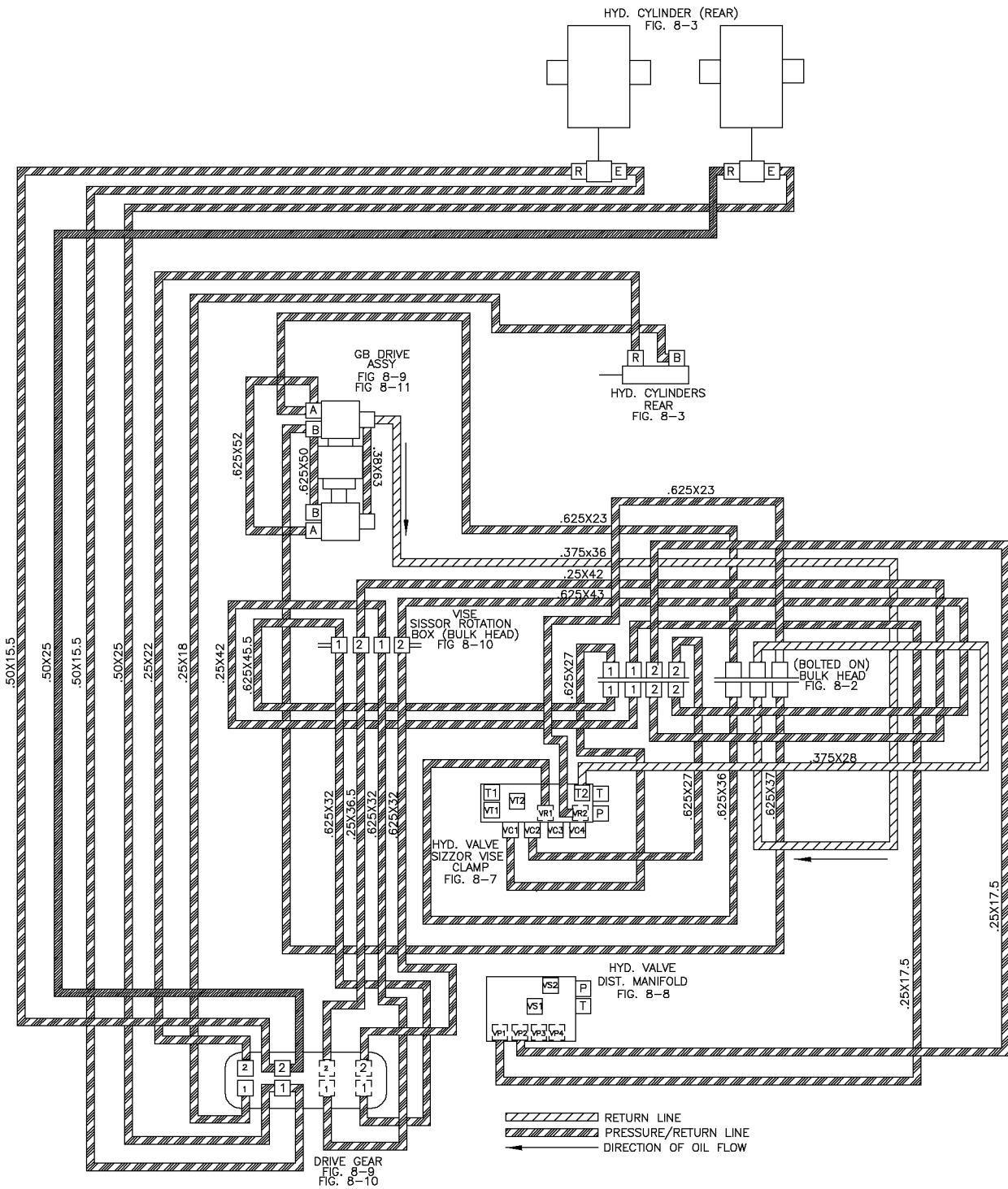

Diagram-Hyd Location Vise Rear Fig 13-8r01

REF. NO.	*	PART NO.	DESCRIPTION	QTY.	REMARKS
		Revision Date	October, 2004		Update In Illustration & Parts List.

Diagram-Hyd Location Vise Rear Fig 13-8

REF. NO.	*	PART NO.	DESCRIPTION	QTY.	REMARKS
		Revision Date	June, 2002		Addition To Manual

Diagram-Hyd Location Vise Front Fig 13-9

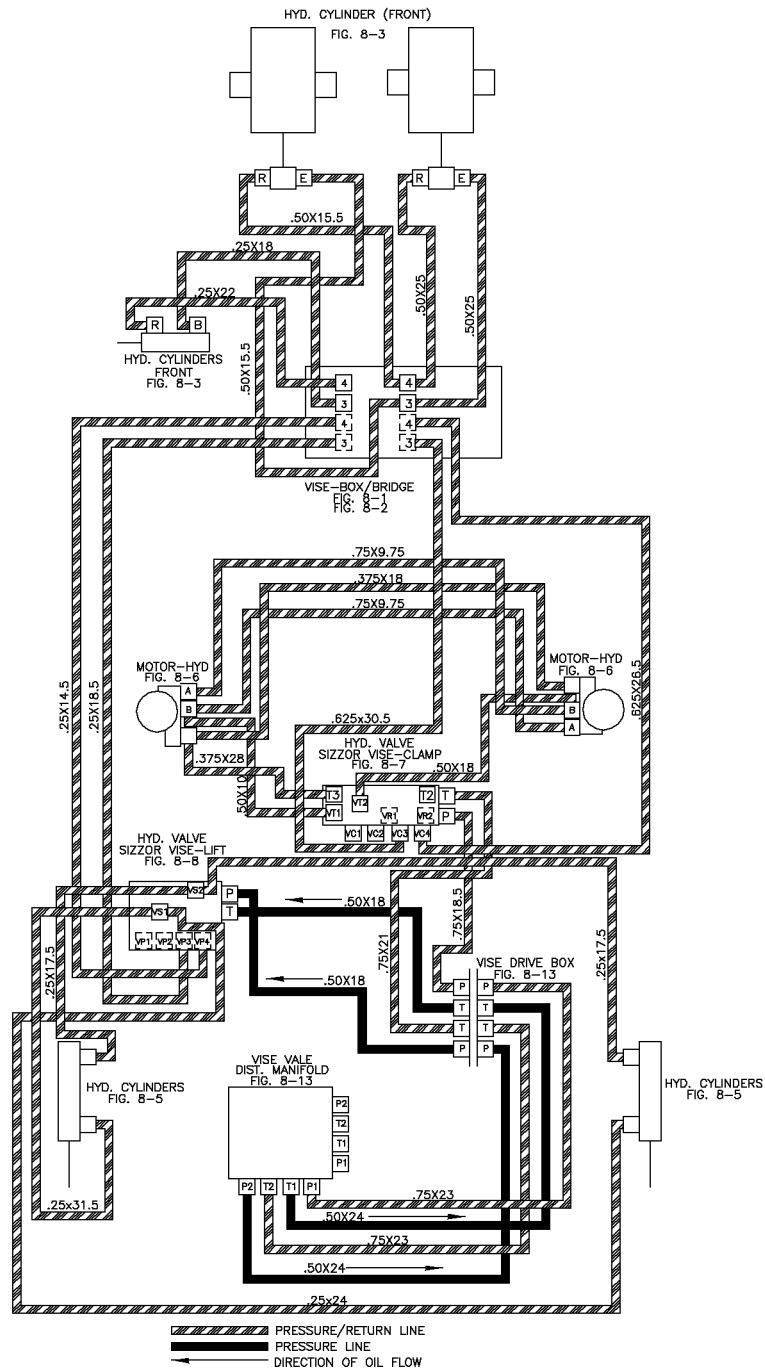

Diagram-Hyd Location Vise Front Fig 13-9

REF. NO.	*	PART NO.	DESCRIPTION	QTY.	REMARKS
		Revision Date	June, 2002		Addition To Manual

Diagram-Hyd Location Triple Stack Pump/Oil Cooler Fig 13-10r01

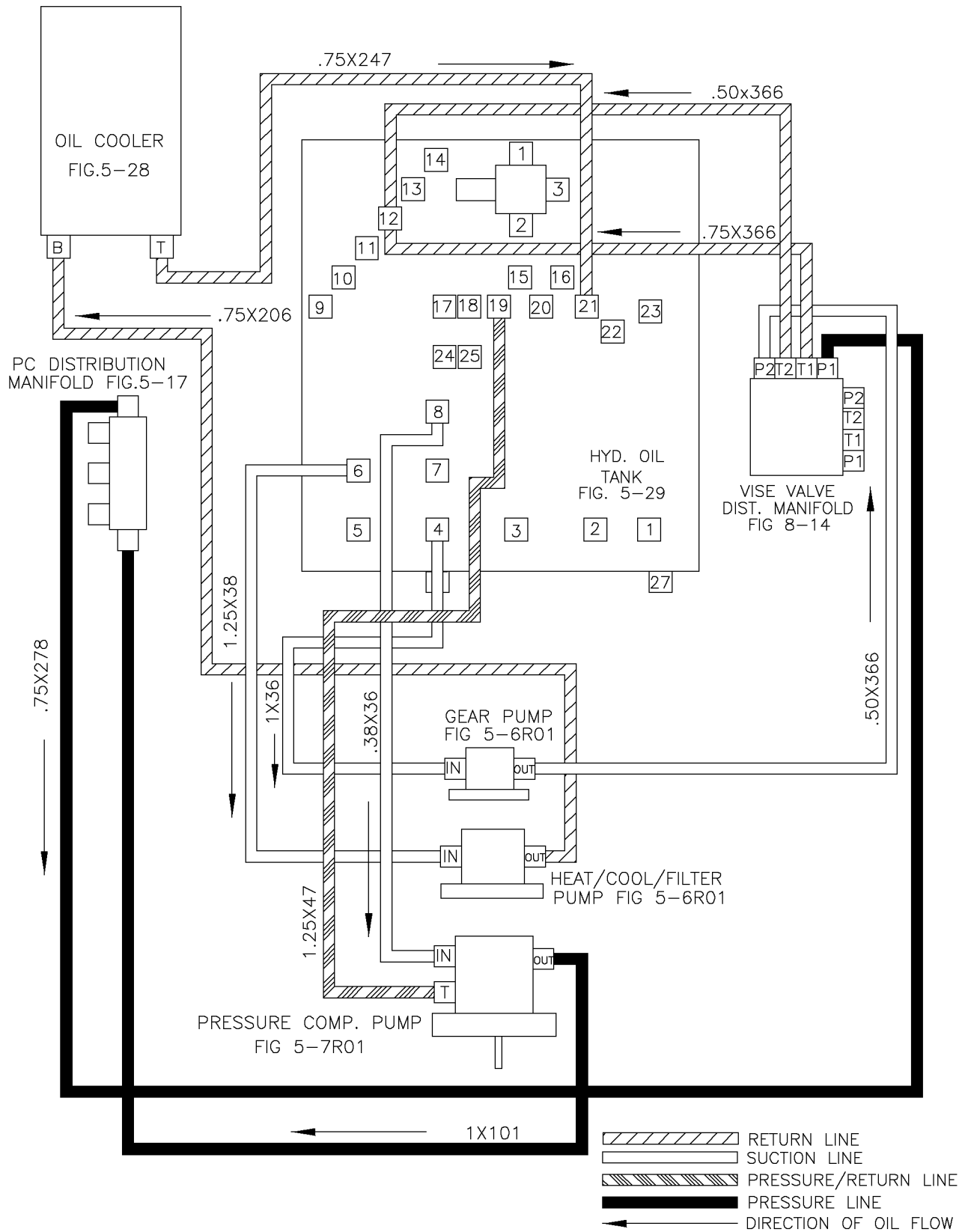

Diagram-Hyd Location Triple Stack Pump/Oil Cooler Fig 13-10r01

REF. NO.	*	PART NO.	DESCRIPTION	QTY.	REMARKS
		Revision Date	October, 2004		Update In Illustration.

Diagram-Hyd Location Triple Stack Pump/Oil Cooler Fig 13-10

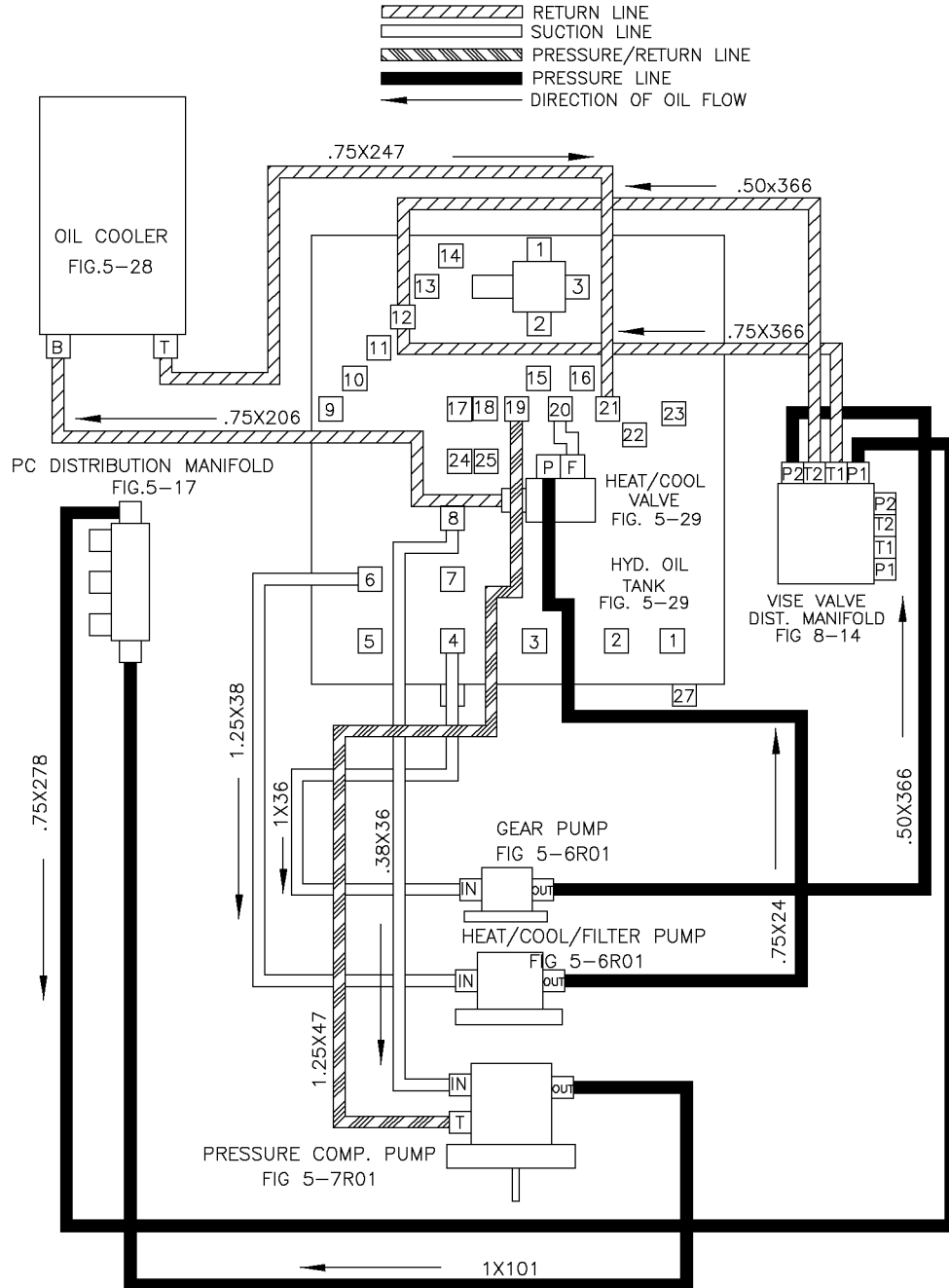

Diagram-Hyd Location Triple Stack Pump/Oil Cooler Fig 13-10

REF. NO.	*	PART NO.	DESCRIPTION	QTY.	REMARKS
		Revision Date	June, 2002		Addition To Manual

Diagram-Hyd Location Track Tension Valve/Cylinder Fig 13-11

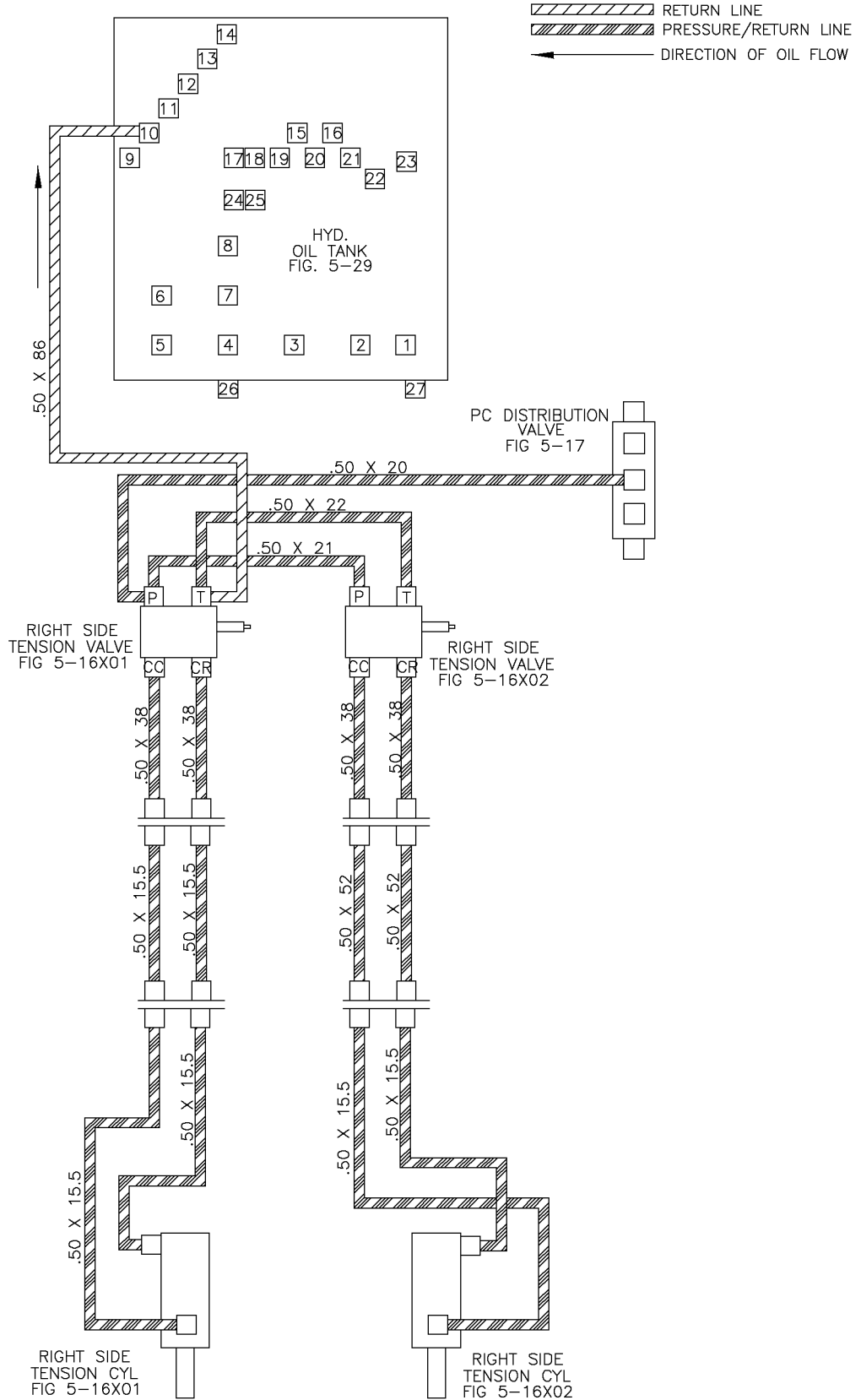

Diagram-Hyd Location Track Tension Valve/Cylinder Fig 13-11

REF. NO.	*	PART NO.	DESCRIPTION	QTY.	REMARKS
		Revision Date	October, 2004		Addition To Manual

Diagram-Hyd Location Cold Start Fig 13-12

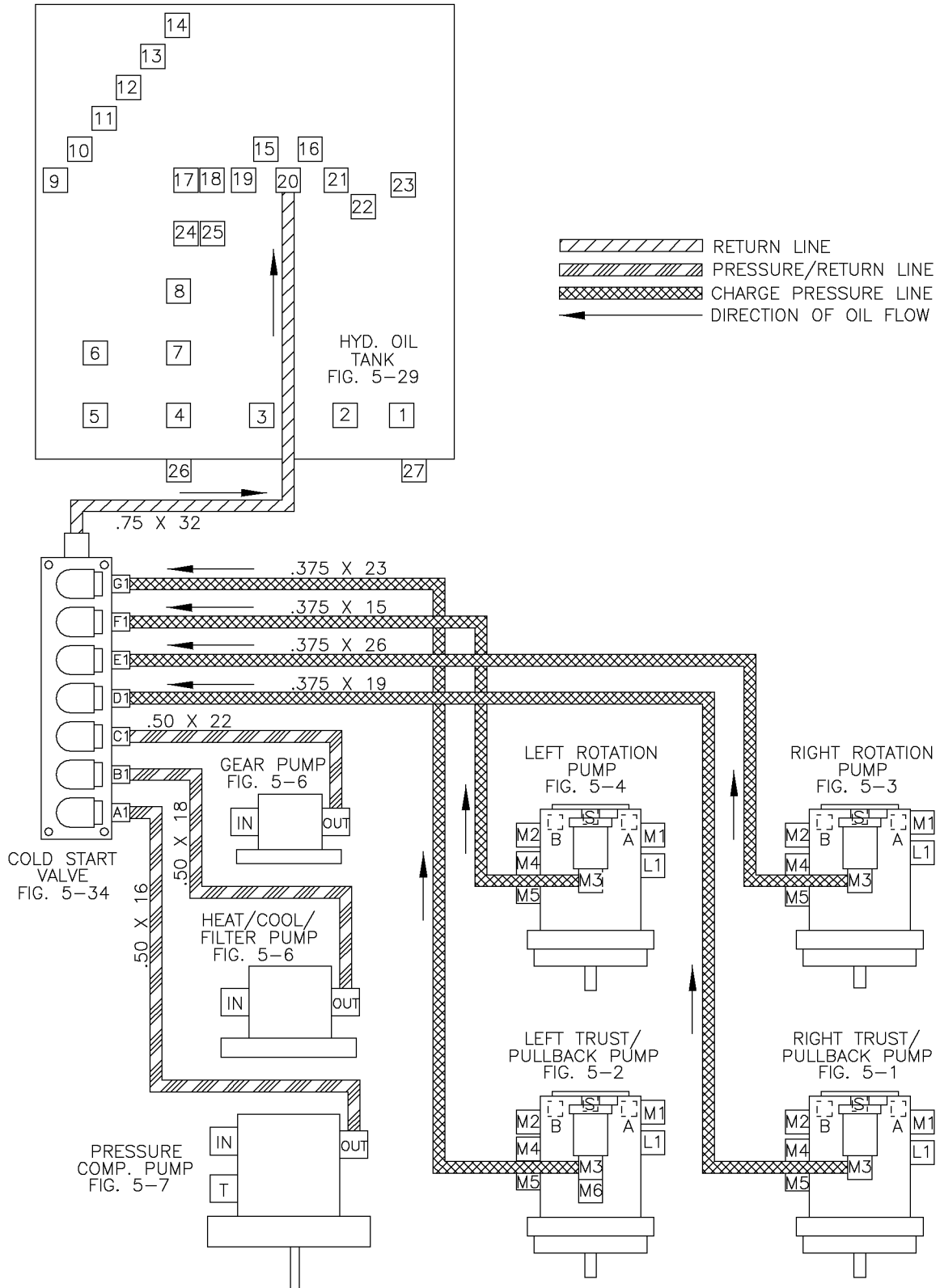

Diagram-Hyd Location Cold Start Fig 13-12

REF. NO.	*	PART NO.	DESCRIPTION	QTY.	REMARKS
		Revision Date	October, 2004		Addition To Manual

This page intentionally left blank.

Revision History

Revision	Date	Page(s)	Description
P1.00	December, 2001	All	First Edition Manual Released
P1.01	June, 2002	TOC, 1-1, 1-2, 1-3, 1-4, 2-1, 2-2, 2-5, 2-7, 2-9, 2-10, 2-13, 2-15, 2-18, 3-2, 3-3, 3-6, 3-11, 3-12, 3-13, 4-2, 5-6, 5-7, 5-9, 5-16, 5-17, 5-20, 5-23, 5-24, 5-29, 5-31, 6-1, 6-2, 6-3, 6-5, 6-10, 6-17, 7-1, 7-3, 7-4, 7-5, 7-12, 8-1, 10-1, 11-1, 12-30, 13-1, 13-2, 13-5, 13-6, 13-7, Added Pages 1-1x01, 1-1x02, 1-1x03, 1-1x04, 1-1x05, 1-2x01, 1-2x02, 1-2x03, 1-2x04, 1-2x05, 5-33, 6-18, 7-13, 8-2, 8-3, 8-4, 8-5, 8-6, 8-7, 8-8, 8-9, 8-10, 8-11, 8-12, 8-13, 8-14, 10-3, 12-41, 12-42, 12-43, 12-44, 12-45, 12-46, 12-47, 12-48, 12-49, 12-50, 13-8, 13-9, 13-10	1st Edition, 1st Revision Released
P1.02	October,2004	TOC, 1-1x01, 1-1x02, 1-1x03, 1-1x04, 1-1x05, 1-2x01, 1-2x02, 1-2x03, 1-2x04, 1-2x05r01, 1-4, 1-5, 2-1, 2-2, 2-3, 2-5, 2-7, 2-8, 2-9r, 2-13, 2-15, 3-3, 3-5, 3-9, 3-10, 3-14, 3-15,4-1, 4-2, 4-3, 5-1, 5-2, 5-3, 5-4, 5-6, 5-7, 5-8, 5-9, 5-12, 5-16, 5-17, 5-18, 5-20, 5-22, 5-29, 5-29=c, 5-3, 6-3, 6-9, 6-10, 6-18, 7-1, 7-2, 7-4, 7-4=c, 7-5, 7-8, 7-12, 7-13, 8-1, 8-2, 8-3, 8-4, 8-5, 8-6, 8-7, 8-8, 8-9, 8-10, 8-11, 8-12, 8-13, 8-14, 9-2, 9-3, 9-4, 9-10, 12-1, 12-25, 12-43, 12-45, 12-46, 13-1, 13-2, 13-3, 13-8, 13-10, Added Pages 5-12x01, 5-12x02, 5-12x03, 5-12x04, 5-12x05, 5-16x01, 5-16x02, 5-25x01, 5-34, 12-51, 12-52, 13-11 and 13-12	1st Edition, 2nd Revision Released

